

# **State of California Laws and Regulations**

**Pertaining to**

**Automotive Repair Dealers, Smog Check Stations and  
Technicians, Official Lamp and Brake Adjusting Stations  
and Adjusters**

*Excerpts from the Business and Professions Code, Civil Code,  
Family Code, Government Code, Health and Safety Code,  
Insurance Code, Penal Code, Public Resources Code,  
Revenues and Taxation Code, Vehicle Code, and  
the California Code of Regulations*

**Includes Statutory Amendments through January 1, 2014  
and Regulations through March 14, 2014**

CALIFORNIA DEPARTMENT OF CONSUMER AFFAIRS  
BUREAU OF AUTOMOTIVE REPAIR  
10949 NORTH MATHER BOULEVARD  
RANCHO CORDOVA, CA 95670

## QUESTIONS ABOUT THIS PUBLICATION?

For CUSTOMER SERVICE ASSISTANCE concerning replacement pages, shipments, billing, reprint permission, or other matters,

please call Customer Service Department at 800-833-9844

email [customer.support@lexisnexis.com](mailto:customer.support@lexisnexis.com)

or visit our interactive customer service website at [www.lexisnexis.com/printcdsc](http://www.lexisnexis.com/printcdsc)

For EDITORIAL **content questions** concerning this publication,

please email: [LLP.CLP@lexisnexis.com](mailto:LLP.CLP@lexisnexis.com)

For **information on other LEXISNEXIS MATTHEW BENDER publications**,

please call us at 800-223-1940

or visit our online bookstore at [www.lexisnexis.com/bookstore](http://www.lexisnexis.com/bookstore)

---

© 2014 Matthew Bender & Company, Inc., a member of the LexisNexis Group.

All rights reserved.

LexisNexis and the Knowledge Burst logo are registered trademarks, and Michie is a trademark of Reed Elsevier Properties Inc., used under license. Matthew Bender is a registered trademark of Matthew Bender Properties Inc.

The California regulations appearing in this publication have been extracted from Barclays Official California Code of Regulations, copyright © 2011, State of California. This material may not be commercially reproduced or sold in printed or electronic form without written permission of Thomson/West, and is subject to the following disclaimer:

THOMSON/WEST MAKES NO WARRANTY OR REPRESENTATION WHATSOEVER, EXPRESS OR IMPLIED, WITH RESPECT TO THE MERCHANTABILITY OR FITNESS FOR ANY PARTICULAR PURPOSE WITH RESPECT TO THE INFORMATION CONTAINED IN THIS PUBLICATION; AND

THOMSON/WEST ASSUMES NO LIABILITY WHATSOEVER WITH RESPECT TO ANY USE OF THIS PUBLICATION OR ANY PORTION THEREOF OR WITH RESPECT TO ANY DAMAGES WHICH MAY RESULT FROM SUCH USE.



Matthew Bender & Company, Inc.

Editorial Offices

701 E. Water Street

Charlottesville, VA 22902

800-446-3410

[www.lexisnexis.com](http://www.lexisnexis.com)

Product Number 2102211

(Pub. 21020)

## Disclaimer

This manual of statutory and administrative code provisions is intended for reference only. Due to the nature of the material, the provisions included herein are subject to change. For complete accuracy contact the Legislative Counsel of California ([www.leginfo.ca.gov](http://www.leginfo.ca.gov)) for statutory updates or the Office of Administrative Law ([www.oal.ca.gov](http://www.oal.ca.gov)) for regulatory updates. LexisNexis also maintains this material online at Lexis.com.



# TABLE OF CONTENTS

*Page*

## BUSINESS & PROFESSIONS CODE

### General Provisions

§ 7.5.	“Conviction”; When action by board following establishment of conviction may be taken; Prohibition against denial of licensure; Application of section .....	1
§ 12.5.	Violation of regulation adopted pursuant to code provision; Issuance of citation .....	1
§ 22.	“Board” .....	1
§ 23.7.	“License” .....	1
§ 23.8.	“Licentiate” .....	1
§ 27.	Information to be provided on Internet; Entities in Department of Consumer Affairs required to comply.....	1
§ 29.5.	Additional qualifications for licensure .....	2
§ 30.	Provision of federal employer identification number or social security number by licensee .....	2
§ 31.	Compliance with judgment or order for support upon issuance or renewal of license .....	3

### DIVISION 1. Department of Consumer Affairs

#### Chapter 1. The Department

§ 100.	Establishment .....	4
§ 101.	Composition of department .....	4
§ 101.6.	Purpose.....	5
§ 101.7.	Meetings of boards; Regular and special .....	5
§ 102.	Assumption of duties of board created by initiative.....	5
§ 102.1.	[Section repealed 2014.] .....	5
§ 102.2.	[Section repealed 2014.] .....	5
§ 102.3.	Interagency agreement to delegate duties of certain repealed boards; Technical committees for regulation of professions under delegated authority; Renewal of agreement .....	5
§ 103.	Compensation and reimbursement for expenses.....	6
§ 104.	Display of licenses or registrations .....	6
§ 105.	Oath of office.....	6
§ 105.5.	Tenure of members of boards, etc., within department.....	6
§ 106.	Removal of board members .....	6
§ 106.5.	Removal of member of licensing board for disclosure of examination information .....	6
§ 107.	Executive officers.....	6
§ 107.5.	Official seals .....	6
§ 108.	Status and powers of boards .....	6
§ 108.5.	Witness fees and expenses.....	7
§ 109.	Review of decisions; Investigations .....	7
§ 110.	Records and property .....	7
§ 111.	Commissioners on examination.....	7
§ 112.	Publication and sale of directories of authorized persons.....	7
§ 113.	Conferences; Traveling expenses .....	7
§ 114.	Reinstatement of expired license of licensee serving in military .....	7
§ 114.3.	Waiver of fees and requirements for active duty members of armed forces and national guard .....	8
§ 115.	Applicability of Section 114.....	8
§ 115.5.	Board required to expedite licensure process for certain applicants; Adoption of regulations.....	8
§ 116.	Audit and review of disciplinary proceedings; Report to Legislature.....	8
§ 117.	[Section repealed 1997.] .....	9
§ 118.	Effect of withdrawal of application; Effect of suspension, forfeiture, etc., of license .....	9
§ 119.	Misdemeanors pertaining to use of licenses .....	9
§ 120.	Possession by surviving spouse of canceled certificates .....	9
§ 121.	Practice during period between renewal and receipt of evidence of renewal.....	9
§ 121.5.	Application of fees to licenses or registrations lawfully inactivated.....	9
§ 122.	Fee for issuance of duplicate certificate .....	10
§ 123.	Conduct constituting subversion of licensing examination; Penalties and damages.....	10
§ 123.5.	Enjoining violations.....	10
§ 124.	Manner of notice .....	10

TABLE OF CONTENTS

§ 125.	Misdemeanor offenses by licensees .....	10
§ 125.3.	Direction to licentiate violating licensing act to pay costs of investigation and enforcement .....	10
§ 125.5.	Enjoining violations; Restitution orders .....	11
§ 125.6.	Unlawful discrimination by licensees .....	11
§ 125.7.	Restraining orders .....	12
§ 125.8.	Temporary order restraining licensee engaged or about to engage in violation of law .....	12
§ 125.9.	System for issuance of citations to licensees; Contents; Fines .....	13
§ 126.	Submission of reports to Governor .....	13
§ 127.	Submission of reports to director .....	13
§ 128.	Sale of equipment, supplies, or services for use in violation of licensing requirements .....	13
§ 128.5.	Reduction of license fees in event of surplus funds .....	14
§ 129.	Handling of complaints; Reports to Legislature .....	14
§ 132.	Requirements for institution or joinder of legal action by state agency against other state or federal agency.....	14
§ 133.	[No section of this number.] .....	14
§ 134.	Proration of license fees .....	14
§ 135.	Reexamination of applicants .....	14
§ 136.	Notification of change of address; Punishment for failure to comply.....	15
§ 137.	Regulations requiring inclusion of license numbers in advertising, etc. ....	15
§ 138.	Notice that practitioner is licensed; Evaluation of licensing examination.....	15
§ 139.	Policy for examination development and validation, and occupational analysis.....	15
§ 140.	Disciplinary action; Licensee's failure to record cash transactions in payment of employee wages.....	16
§ 141.	Disciplinary action by foreign jurisdiction; Grounds for disciplinary action by state licensing board.....	16
§ 142.	Authority to synchronize renewal dates of licenses; Abandonment date for application; Delinquency fee.....	16
§ 143.	Proof of license as condition of bringing action for collection of compensation .....	16
§ 143.5.	Provision in agreements to settle certain causes of action prohibited; Adoption of regulations; Exemptions .....	16
§ 144.	Requirement of fingerprints for criminal record checks; Applicability.....	17
Chapter 1.5. Unlicensed Activity Enforcement		
§ 145.	Legislative findings and declarations.....	17
§ 146.	Violations of specified authorization statutes as infractions; Punishment .....	17
§ 146.5.	[Section repealed 2008.] .....	18
§ 147.	Authority to issue written notice to appear in court .....	18
§ 148.	Establishment of administrative citation system.....	18
§ 149.	Notice to cease advertising in telephone directory; Contest and hearing; Disconnection of service .....	18
Chapter 3. Funds of the Department		
§ 200.	Deposit of revenues, etc.; Refunds .....	19
§ 206.	Dishonored check tendered for payment of fine, fee, or penalty.....	19
Chapter 4. Consumer Affairs		
Article 1. General Provisions and Definitions.....		
§ 300.	Citation of chapter .....	19
§ 301.	Declaration of intent.....	19
§ 302.	Definitions.....	19
§ 303.	Division of Consumer Services; Chief.....	20
Article 2. Director and Employees.....		
§ 305.	Administration of chapter.....	20
§ 306.	Employment matters.....	20
§ 307.	Experts and consultants .....	20
Article 3. Powers and Duties.....		
§ 310.	Director's powers and duties .....	20
§ 311.	Interdepartmental committee .....	20
§ 312.	Report to Governor and Legislature.....	21
§ 313.	Establishment of library .....	21
§ 313.1.	Compliance with section as requirement for effectiveness of specified rules or regulations; Submission of records; Authority for disapproval.....	21
§ 313.2.	Adoption of regulations in conformance with Americans with Disabilities Act .....	21

§ 313.5.	Publication of consumer information bibliography .....	21
Article 4.	Representation of Consumers .....	21
§ 320.	Intervention in administrative or judicial proceedings.....	21
§ 321.	Commencement of legal proceedings .....	22
Article 5.	Consumer Complaints .....	22
§ 325.	Actionable complaints .....	22
§ 326.	Proceedings on receipt of complaint .....	22
Chapter 6.	Public Members	
§ 450.	Qualifications generally .....	22
§ 450.2.	Avoiding conflict of interest .....	22
§ 450.3.	Conflicting pecuniary interests .....	23
§ 450.5.	Prior industrial and professional pursuits.....	23
§ 450.6.	Age .....	23
§ 451.	Delegation of duties .....	23
§ 452.	“Board” .....	23
Chapter 7.	Licensee	
§ 460.	Powers of local governmental entities .....	23
§ 461.	Asking applicant to reveal arrest record prohibited.....	23
§ 462.	Inactive category of licensure .....	23
Chapter 9.	Certification of Third-Party Dispute Resolution Processes for New Motor Vehicles	
§ 472.	Definitions.....	24
§ 472.1.	Program for certifying third party dispute resolution processes used for arbitration of disputes .....	24
§ 472.2.	Availability to buyers or lessees of new motor vehicle; Application for certification; Final determination.....	24
§ 472.5.	Certification Account; Statement of motor vehicles distributed; Fees; Notification of amount to fund program; Adoption of regulations .....	25
DIVISION 1.2.	Joint Committee on Boards, Commissions, and Consumer Protection	
Chapter 1.	Review of Boards under the Department of Consumer Affairs	
§ 473.1.	[Section repealed 2011.] .....	25
§ 473.3.	[Section repealed 2011.] .....	25
DIVISION 1.5.	Denial, Suspension and Revocation of Licenses	
Chapter 1.	General Provisions	
§ 475.	Applicability of division .....	26
§ 476.	Exemptions .....	26
§ 477.	“Board”; “License” .....	26
§ 478.	“Application”; “Material” .....	26
Chapter 2.	Denial of Licenses	
§ 480.	Grounds for denial; Effect of obtaining certificate of rehabilitation .....	26
§ 481.	Crime and job-fitness criteria .....	27
§ 482.	Rehabilitation criteria .....	27
§ 483.	[Section renumbered 1987.] .....	27
§ 484.	Attestation to good moral character of applicant.....	27
§ 485.	Procedure upon denial.....	27
§ 486.	Contents of decision or notice .....	27
§ 487.	Hearing; Time .....	27
§ 488.	Hearing request .....	27
§ 489.	Denial of application without a hearing.....	27
Chapter 3.	Suspension and Revocation of Licenses	
§ 490.	Grounds for suspension or revocation; Discipline for substantially related crimes; Conviction; Legislative findings.....	28
§ 490.5.	Suspension of license for failure to comply with child support order .....	28
§ 491.	Procedure upon suspension or revocation.....	28
§ 492.	Effect of completion of drug diversion program on disciplinary action or denial of license.....	28
§ 493.	Evidentiary effect of record of conviction of crime substantially related to licensee’s qualifications, functions, and duties.....	28
§ 494.	Interim suspension or restriction order .....	29

TABLE OF CONTENTS

§ 494.5. Agency actions when licensee is on certified list; Definitions; Collection and distribution of certified list information; Timing; Notices; Challenges by applicants and licensees; Release forms; Interagency agreements; Fees; Remedies; Inquiries and disclosure of information; Severability ..... 30

Chapter 4. Public Repeals

§ 495. Public repeal of licentiate or certificate holder for act constituting grounds for suspension or revocation of license or certificate; Proceedings ..... 33

Chapter 5. Examination Security

§ 496. Grounds for denial, suspension, or revocation of license ..... 33

§ 498. Fraud, deceit or misrepresentation as grounds for action against license ..... 33

§ 499. Action against license based on licentiate's actions regarding application of another ..... 33

DIVISION 3. Professions and Vocations Generally

Chapter 20. Electronic and Appliance Repair

Article 1. General Provisions ..... 34

§ 9806. Installation by automobile dealer or manufacturer ..... 34

§ 9807. Service dealers may install, calibrate, service, maintain, and monitor ignition interlock devices ..... 34

Chapter 20.3. Automotive Repair

Article 1. General Provisions ..... 34

§ 9880. Chapter's scope and citation ..... 34

§ 9880.1. Definitions ..... 34

§ 9880.2. Exemptions from registration ..... 35

§ 9880.3. Priority of bureau; Protection of the public ..... 35

Article 2. Administration ..... 35

§ 9882. Bureau of Automotive Repair; Adoption of regulations ..... 35

§ 9882.1. Appointment, compensation, and supervision of personnel ..... 35

§ 9882.2. Chief of bureau ..... 35

§ 9882.3. Officials exercising director's powers and duties ..... 36

§ 9882.4. Maintenance and availability of record of registered dealers; Bureau newsletter ..... 36

§ 9882.5. Investigation of violations; Complaint procedures; Compensation ..... 36

§ 9882.14. Standards for installation of ignition interlock devices ..... 36

Article 3. Registration Procedure ..... 36

§ 9884. Registration fee and forms ..... 36

§ 9884.1. Application and fees when business has more than one facility ..... 37

§ 9884.2. Issuance of registration; Duties of director ..... 37

§ 9884.3. Termination of registration on nonpayment of renewal fee ..... 37

§ 9884.4. Termination of registration when information not current ..... 37

§ 9884.5. Cancellation of registration following failure to renew in three years after expiration; Renewal within three years ..... 37

§ 9884.6. Persons who must register ..... 37

§ 9884.7. Denial, suspension, revocation, or probation of registration ..... 37

§ 9884.76. Automotive repair dealers; Failure to restore airbag to original operating condition; Misdemeanor ..... 38

§ 9884.8. Recording on invoice ..... 38

§ 9884.9. Written estimates; Consent of customer; Acknowledgment; Authorization for charges in excess of estimate ..... 38

§ 9884.10. Return of replaced parts to customer ..... 39

§ 9884.11. Maintenance and inspection of records ..... 39

§ 9884.12. Provisions governing proceedings affecting registration ..... 39

§ 9884.13. Administrative jurisdiction after expiration of valid registration ..... 39

§ 9884.14. Enjoining violation ..... 39

§ 9884.15. Filing charges with district or city attorney ..... 39

§ 9884.16. Registration as prerequisite to lien or suit ..... 39

§ 9884.17. Sign placed in dealer locations ..... 39

§ 9884.18. Individual's civil action against dealer ..... 39

§ 9884.19. Bureau's regulations ..... 40

§ 9884.20. Limitations period for filing accusation against automotive repair dealers ..... 40



## TABLE OF CONTENTS

§ 9884.21.	Probationary registration; Terms and conditions; Dismissed conviction; Evidence of rehabilitation; Standard terms .....	40
§ 9884.22.	Revocation, suspension, or denial of registration; Statement of reasons for denial; Copy of criminal history record; Hearings .....	40
Article 4.	Revenue .....	41
§ 9886.	Vehicle and Inspection Repair Fund .....	41
§ 9886.1.	Director's report to State Controller and payment of revenues into State Treasury .....	41
§ 9886.2.	Availability of funding .....	41
§ 9886.3.	Registration fee schedule .....	41
§ 9886.4.	Payments from fund .....	41
Article 5.	Licenses .....	41
§ 9887.1.	Licensing for lamp and brake adjusting stations .....	41
§ 9887.2.	Application and fees .....	41
§ 9887.3.	Nontransferability, and cancellation and replacement or duplication, of licenses .....	42
§ 9887.4.	Illegality of violation of regulation .....	42
Article 6.	Lamp and Brake Adjusting Stations .....	42
§ 9888.1.	Definitions .....	42
§ 9888.2.	Adoption of regulations; Approval of testing equipment and laboratories .....	42
§ 9888.3.	Required licensing of stations and adjusters .....	42
§ 9888.4.	Licensing of, and certification by, fleet owner stations .....	42
Article 7.	Denial, Suspension and Revocation .....	42
§ 9889.1.	Authority of director; Provisions governing proceedings .....	42
§ 9889.2.	Grounds for denial of license .....	42
§ 9889.3.	Grounds for disciplinary action against licensee .....	43
§ 9889.4.	Conviction, and license suspension, revocation, or refusal thereon .....	43
§ 9889.5.	Permitted disciplinary actions .....	43
§ 9889.6.	Surrender of revoked or suspended license .....	43
§ 9889.7.	Continuance of director's jurisdiction .....	43
§ 9889.8.	Period of limitations for filing accusations .....	43
§ 9889.9.	Revocation or suspension of additional license .....	43
§ 9889.10.	Reinstatement of suspended or revoked license .....	44
Article 8.	Lamp and Brake Adjustment Certificates .....	44
§ 9889.15.	Definitions .....	44
§ 9889.16.	Lamp or brake adjustment certificate .....	44
§ 9889.19.	Charging fees for certificates .....	44
Article 9.	Penalties .....	44
§ 9889.20.	Misdemeanor offense and punishment therefor .....	44
§ 9889.21.	Infraction, and punishment therefor .....	44
§ 9889.22.	Perjury .....	44
Article 10.5.	Auto Body Repair .....	44
§ 9889.50.	Legislative findings .....	44
§ 9889.51.	"Auto body repair shop" .....	45
§ 9889.52.	Application for registration .....	45
§ 9889.53.	Inclusion of repairer's identification number on check issued under collision insurance policy .....	45
Article 11.	Auto Body Repair Study .....	45
§ 9889.66.	Registration form .....	45
§ 9889.68.	Identification requirement for insurance check or draft issued to repairer .....	45
DIVISION 5. Weights and Measures		
Chapter 14.5. Service Stations		
§ 13650.	"Service station" .....	45
§ 13651.	Provision of air, water, pressure gauge, and restrooms; Exceptions .....	45
§ 13652.	Punishment for intentional violations; Compliance after receiving notice .....	46
§ 13653.	Enforcement .....	46
§ 13660.	Refueling service for disabled person .....	46

TABLE OF CONTENTS

DIVISION 7. General Business Regulations

PART 2. Preservation and Regulation of Competition

Chapter 5. Enforcement

§ 17200. Definition ..... 48

§ 17201. Person ..... 48

§ 17201.5. “Board within the Department of Consumer Affairs”; “Local consumer affairs agency” ..... 48

§ 17202. Specific or preventive relief ..... 48

§ 17203. Injunctive relief; Court orders ..... 48

§ 17204. Actions for Injunctions by Attorney General, District Attorney, County Counsel, and City Attorneys ..... 48

§ 17205. Cumulative penalties ..... 48

§ 17206. Civil penalty for violation of chapter ..... 48

§ 17206.1. Additional civil penalty; Acts against senior citizens or disabled persons ..... 49

§ 17207. Violation of injunction ..... 50

§ 17208. Limitation of actions ..... 50

§ 17209. Notice of issue in action before appellate court ..... 50

PART 3. Representations to the Public

Chapter 1. Advertising

Article 1. False Advertising in General ..... 51

§ 17500. False or misleading statements generally ..... 51

§ 17500.1. Prohibition against enactment of rule, regulation, or code of ethics restricting or prohibiting advertising not violative of law ..... 51

§ 17500.3. Solicitation of sales at residence or by telephone ..... 51

§ 17500.5. Advertisements as to quantity of article to be sold to single customer ..... 52

§ 17501. Value determinations; Former price advertisements ..... 52

§ 17502. Exemption of broadcasting stations and publishers from provisions of article ..... 52

§ 17503. [No section of this number.] ..... 52

§ 17504. Advertisement of price of goods or services sold in multiple units ..... 52

§ 17505. Misrepresentation as to nature of business ..... 53

§ 17505.2. Requirements for representing oneself as recreation therapist; Civil action for violation ..... 53

§ 17506. “Person” ..... 53

§ 17506.5. “Board within the Department of Consumer Affairs”; “Local consumer affairs agency” ..... 53

§ 17507. Disclosure of price differentials respecting more than one article of merchandise or type of service within same class ..... 53

§ 17508. Purportedly fact-based or brand-comparison advertisements ..... 54

§ 17509. Advertisements soliciting purchase of product conditioned on purchase of different product; Price disclosure; Good faith exemption for publishers ..... 54

Article 2. Particular Offenses ..... 55

§ 17533.6. Use of term, symbol, or content indicating governmental connection; Exception in the case of endorsement; Solicitation indicating governmental connection; Violation; Remedies ..... 55

§ 17533.7. Use of words “Made in U.S.A.” or similar words ..... 56

§ 17534. Punishment for violation ..... 56

§ 17534.5. Remedies or penalties cumulative ..... 56

§ 17535. Obtaining injunctive relief ..... 56

§ 17535.5. Penalty for violating injunction; Proceedings; Disposition of proceeds ..... 56

§ 17536. Penalty for violations of chapter; Proceedings; Disposition of proceeds ..... 57

§ 17536.5. Notice of issue in action before appellate court ..... 57

§ 17537. Conditioning prize-winning on purchase or rental ..... 57

§ 17537.1. Offering prize or gift as inducement to visit location or attend sales presentation; Required disclosures ..... 58

§ 17537.2. What constitutes deceptive and unfair trade practices with respect to inducement to visit location or attend sales presentation ..... 60

§ 17537.4. Civil action for making prohibited offers ..... 61

§ 17537.5. False statements relating to energy conservation products or services ..... 61

§ 17537.7. Unlawful use of specified terms to refer to dealer’s cost for motor vehicle ..... 61

§ 17537.11. Misleading coupon ..... 61

Article 7.5. Automotive Products ..... 61

§ 17582. Bittering agent in engine coolant or antifreeze ..... 61

## TABLE OF CONTENTS

## CIVIL CODE

## DIVISION 3. Obligations

## PART 4. Obligations Arising from Particular Transactions

## TITLE 1.7. Consumer Warranties

## Chapter 1. Consumer Warranty Protection

Article 1. General Provisions .....	63
§ 1790. Title.....	63
§ 1790.1. Enforceability of waiver .....	63
§ 1790.2. Severability.....	63
§ 1790.3. Construction in case of conflict with Commercial Code .....	63
§ 1790.4. Cumulative remedies .....	63
Article 2. Definitions .....	63
§ 1791. Definitions.....	63
§ 1791.1. “Implied warranty of merchantability”; “Implied warranty of fitness” .....	64
§ 1791.2. “Express warranty” .....	65
§ 1791.3. “As is”; “With all faults” .....	65
Article 3. Sale Warranties .....	65
§ 1792. Implied warranty of merchantability .....	65
§ 1792.1. Manufacturer’s implied warranty of fitness for particular purpose .....	65
§ 1792.2. Retailer’s or distributor’s implied warranty of fitness for particular purpose .....	65
§ 1792.3. Waiver of implied warranties .....	65
§ 1792.4. Disclaimer of implied warranty .....	66
§ 1792.5. “As is” sales .....	66
§ 1793. Express warranties.....	66
§ 1793.1. Form of express warranties; Requirements on distribution of warranty or product registration car or form, or electronic online warranty or product registration forms .....	66
§ 1793.2. Duties of manufacturer making express warranty .....	67
§ 1793.22. Reasonable number of attempts to conform vehicle to warranties; Dispute resolution process; Transfer of vehicle.....	68
§ 1793.23. Disclosures required of seller of returned vehicle; “Lemon Law Buyback” .....	70
§ 1793.24. Warranty buyback notice .....	70
§ 1793.25. Sales tax reimbursement to vehicle manufacturer after restitution under express warranty.....	71
§ 1793.26. Restrictions on confidentiality clause, gag clause, or other similar clause associated with reacquisition of motor vehicle.....	72
§ 1793.3. Failure to provide service facility in conjunction with express warranty .....	72
§ 1793.4. Time to exercise option for service of item under express warranty .....	73
§ 1793.5. Liability of manufacturer making express warranties for failure to maintain service facilities .....	73
§ 1793.6. Manufacturer’s liability to independent serviceman performing services or incurring obligations on express warranties .....	73
§ 1794. Buyer’s damages, penalties and fees .....	73
§ 1794.1. Seller’s and serviceman’s damages .....	74
§ 1794.4. Service contract in lieu of warranty.....	74
§ 1794.41. Vehicle, home appliance, or home electronic product service contract; Requirements; Applicability; Conflicts with insurance provisions .....	75
§ 1794.5. Alternative suggestions for repair of item under express warranty .....	75
§ 1795. Liability of nonmanufacturer making express warranty .....	75
§ 1795.1. Application of chapter to components of air conditioning system .....	76
§ 1795.5. Obligations of distributors or sellers of used goods.....	76
§ 1795.6. Tolling the warranty period .....	76
§ 1795.7. Effect of tolling on manufacturer’s liability .....	76

## FAMILY CODE

## DIVISION 17. Support Services

## Chapter 2. Child Support Enforcement

Article 2. Collections and Enforcement .....	77
§ 17520. Consolidated lists of persons; License renewals; Review procedures; Report to Legislature; Rules and regulations; Forms; Use of information; Suspension or revocation of driver’s license; Severability.....	77

GOVERNMENT CODE

TITLE 1. General

DIVISION 4. Public Officers and Employees

Chapter 9.7. Public Safety Officers

§ 3309.5. Proceeding for violations of rights and protections; Jurisdiction; Relief; Frivolous actions; Civil penalty; Actual damages..... 82

DIVISION 7. Miscellaneous

Chapter 3.5. Inspection of Public Records

Article 1. General Provisions ..... 83

§ 6250. Legislative finding and declaration ..... 83

§ 6251. Citation of chapter..... 83

§ 6252. Definitions..... 83

§ 6252.5. Elected member or officer’s access to public records..... 83

§ 6253. Time for inspection of public records; “Unusual circumstances” ..... 83

§ 6253.1. Agency to assist in inspection of public record..... 84

§ 6253.2. (First of two; Operative term contingent) Disclosure of information for in-home supportive services, personal care services, or Community First Choice Option..... 84

§ 6253.2. (Second of two; Operative date contingent) Disclosure of information for in-home supportive services or personal care services..... 85

§ 6253.3. Control of disclosure by another party ..... 86

§ 6253.31. Contract of state or local agency requiring private entity to review, audit or report on agency ..... 86

§ 6253.4. Records to be made available..... 86

§ 6253.9. Information in electronic format..... 86

§ 6254. Records exempt from disclosure requirements ..... 87

TITLE 2. Government of the State of California

DIVISION 3. Executive Department

PART 1. State Departments and Agencies

Chapter 2. State Departments

Article 2. Investigations and Hearings ..... 92

§ 11180. Matters that may be investigated and prosecuted ..... 92

§ 11180.5. Assistance of state agencies in conducting investigation of unlawful activities; Request of prosecuting attorney or Attorney General; Disclosure of information ..... 92

§ 11181. Acts authorized in connection with investigations and actions ..... 92

§ 11182. Delegation of powers..... 92

§ 11183. Divulging information; Offense; Disqualification ..... 92

§ 11184. Process; Subpoenas; Service; Compensation..... 93

§ 11185. Attendance as witness; Natural persons; Witness that is not a natural person; Production of documents ..... 93

§ 11186. Compelling attendance as witness, giving of testimony, and production of papers ..... 93

§ 11187. Petition to compel giving of testimony or production of documents; Objections..... 93

§ 11188. Order for person summoned to show cause; Order to appear; Contempt..... 94

§ 11189. Depositions; Attendance of witnesses; Production of documents; Procedure..... 94

§ 11190. Right of party to attendance of witnesses ..... 94

§ 11191. Fees and mileage of witnesses..... 94

Chapter 3.5. Administrative Regulations and Rulemaking

Article 1. General..... 95

§ 11340. Legislative findings and declarations ..... 95

§ 11340.1. Declarations and intent regarding establishment of Office of Administrative Law ..... 95

§ 11340.2. Office of Administrative Law; Director and deputy director..... 95

§ 11340.3. Employment and compensation of assistants and other employees..... 95

§ 11340.4. Recommendations on administrative rulemaking..... 95

§ 11340.5. Adoption of guidelines, bulletins and manuals as regulations ..... 95

§ 11340.6. Petition requesting adoption, amendment, or repeal of regulation; Contents ..... 96

§ 11340.7. Procedure upon petition requesting adoption, amendment or repeal of regulation..... 96

§ 11340.85. Electronic communications..... 96

§ 11340.9. Inapplicable provisions..... 97

§ 11341. Identification numbers..... 97

§ 11342.1. Authority not conferred on state agencies..... 97

§ 11342.2. Consistency with statute; Effectuation of purpose of statute ..... 98

§ 11342.4. Regulations ..... 98

Article 2. Definitions ..... 98

§ 11342.510. Governing definitions ..... 98

§ 11342.520. “Agency” ..... 98

§ 11342.530. “Building standard” ..... 98

§ 11342.535. “Cost impact” ..... 98

§ 11342.540. “Director” ..... 98

§ 11342.545. “Emergency” ..... 98

§ 11342.548. “Major regulation” ..... 98

§ 11342.550. “Office” ..... 98

§ 11342.560. “Order of repeal” ..... 98

§ 11342.570. “Performance standard” ..... 98

§ 11342.580. “Plain English” ..... 98

§ 11342.590. “Prescriptive standard” ..... 98

§ 11342.595. “Proposed action” ..... 98

§ 11342.600. “Regulation” ..... 98

§ 11342.610. “Small Business” ..... 99

Article 3. Filing and Publication ..... 99

§ 11343. Procedure ..... 99

§ 11343.1. Style of regulations; Endorsement..... 100

§ 11343.2. Endorsement of time and date of filing and maintenance of file for public inspection..... 100

§ 11343.3. Vehicle weight impacts and ability of vehicle manufacturers or operators to comply with laws limiting weight of vehicles to be taken into account when promulgating administrative regulations ..... 100

§ 11343.4. Effective date of regulation or order of repeal; Applicability ..... 100

§ 11343.5. Filing copies of Code of Regulations or Regulatory Code Supplement..... 100

§ 11343.6. Rebuttable presumptions raised by filing of certified copy..... 100

§ 11343.8. Filing and publication of regulation or order of repeal not required to be filed ..... 100

Article 4. The California Code of Regulations, the California Code of Regulations Supplement, and the California Regulatory Notice Register..... 101

§ 11344. Publication of Code of Regulations and Code of Regulations Supplement; Availability of regulations on internet..... 101

§ 11344.1. Publication of Regulatory Notice Register ..... 101

§ 11344.2. Furnishing Code and Supplement to county clerks or delegates ..... 101

§ 11344.3. Time of publication of documents ..... 101

§ 11344.4. Sale of Code, Supplement and Regulatory Notice Register..... 102

§ 11344.6. Rebuttable presumption raised by publication of regulations ..... 102

§ 11344.7. Authority of state agencies to purchase copies of Code, Supplement, or Register or to print and distribute special editions ..... 102

§ 11344.9. “California Administrative Code”; “California Administrative Notice Register”; “California Administrative Code Supplement” ..... 102

§ 11345. Identification number not required ..... 102

Article 5. Public Participation: Procedure for Adoption of Regulations ..... 102

§ 11346. Purpose and applicability of article; Subsequent legislation ..... 102

§ 11346.1. Emergency regulations and orders of repeal ..... 103

§ 11346.2. Availability to public of copy of proposed regulation; Initial statement of reasons for proposed action ..... 103

§ 11346.3. Assessment of potential for adverse economic impact on businesses and individuals ..... 104

§ 11346.36. Adoption of regulations for conducting standardized regulatory impact analyses; Submission; Publication..... 105

§ 11346.4. Notice of proposed action ..... 106

§ 11346.45. Increased public participation ..... 106

§ 11346.5. Contents of notice of proposed adoption, amendment, or repeal of regulation ..... 107

§ 11346.6. Duty of agency, upon request from person with certain disability, to provide narrative description of proposed regulation..... 108

§ 11346.7. Link on website ..... 109

TABLE OF CONTENTS

§ 11346.8. Hearing ..... 109

§ 11346.9. Final statements of reasons for proposing adoption or amendment of regulation; Informative digest ..... 110

§ 11347. Decision not to proceed with proposed action ..... 110

§ 11347.1. Addition to rulemaking file ..... 110

§ 11347.3. File of rulemaking; Contents and availability of file ..... 111

§ 11348. Rulemaking records ..... 111

Article 6. Review of Proposed Regulations ..... 112

§ 11349. Definitions ..... 112

§ 11349.1. Review of regulations; Regulations to govern review process; Return to adopting agency ..... 112

§ 11349.1.5. Review of standardized regulatory impact analyses; Report; Notice of noncompliance ..... 113

§ 11349.2. Adding material to file ..... 113

§ 11349.3. Time for review of regulations; Procedure on disapproval; Return of regulations ..... 113

§ 11349.4. Rewriting and resubmission of regulation; Review ..... 113

§ 11349.5. Governor’s review of decisions ..... 114

§ 11349.6. Review by office of emergency regulation ..... 114

Article 7. Review of Existing Regulations ..... 115

§ 11349.7. Priority review of regulations ..... 115

§ 11349.8. Repeal of regulation for which statutory authority is repealed, ineffective or inoperative ..... 115

§ 11349.9. Review of notice of repeal ..... 116

Article 8. Judicial Review ..... 116

§ 11350. Judicial declaration regarding validity of regulation; Grounds for invalidity ..... 116

§ 11350.3. Judicial declaration as to validity of disapproved or repealed regulation ..... 117

PART 2. Constitutional Officers

Chapter 6. Attorney General

Article 10. Securities and Commodities ..... 117

§ 12657. Definitions ..... 117

§ 12658. Action by Attorney General to enjoin acts or enforce compliance with securities or commodities law; Injunction; Appointment of designated fiduciary; Claim for ancillary relief; Judgment for restitution ..... 117

§ 12659. Investigations by Attorney General; Publication of information; Refusal to obey subpoena; Exemption from prosecution ..... 118

§ 12660. Civil penalties for violation of securities or commodities law; Nonexclusive remedies; Time limitation for actions ..... 118

§ 12661. Powers of Attorney General to take actions under federal Commodity Exchange Act or other laws ..... 118

HEALTH AND SAFETY CODE

DIVISION 20. Miscellaneous Health and Safety Provisions

Chapter 6.5. Hazardous Waste Control

Article 13.5. Motor Vehicle Brake Friction Materials

§ 25250.50. Definitions ..... 119

§ 25250.51. Proscription against sale of brake friction materials containing enumerated constituents ..... 119

§ 25250.52. Sale of brake friction material exceeding 5 percent copper by weight ..... 120

§ 25250.53. Sale of brake friction material exceeding 0.5 percent copper by weight ..... 120

§ 25250.54. Extension of deadline ..... 120

§ 25250.55. Exemption from article ..... 121

§ 25250.60. Testing and marking brake friction materials; Compliance; Certification ..... 121

§ 25250.62. Violation; Civil fine; Replacement ..... 122

§ 25250.64. Brake Friction Materials Water Pollution Fund established; Expenditure to implement article ..... 122

§ 25250.65. (Repealed January 1, 2027) Report and recommendations on implementation of vehicle brake copper reduction efforts ..... 123

DIVISION 26. Air Resources

PART 1. General Provisions and Definitions

Chapter 2. Definitions

§ 39010. Definitions governing construction ..... 123

TABLE OF CONTENTS

§ 39011.5. “Agricultural source of air pollution” or “agricultural source”; Applicability of certain district rules or regulations; Authority of district to regulate a source ..... 123

§ 39012. “Air basin” ..... 124

§ 39013. “Air contaminant”; “Air pollutant” ..... 124

§ 39014. “Ambient air quality standards” ..... 124

§ 39016.5. “Bureau” ..... 124

§ 39018. “Certification” ..... 124

§ 39019. “Certified device” ..... 124

§ 39021. “Commercial vehicle” ..... 124

§ 39024.5. “Department” ..... 124

§ 39024.6. “Direct import vehicle” ..... 124

§ 39025. “District” ..... 124

§ 39027. “Emission standards” ..... 124

§ 39027.3. Definitions ..... 124

§ 39027.5. (Operative date contingent; Operative term contingent) “Emissions retrofit device” ..... 125

§ 39028. “Exhaust device” ..... 125

§ 39029. “Exhaust emissions” ..... 125

§ 39032.5. “Gross polluter” ..... 125

§ 39033. “Heavy-duty” ..... 125

§ 39035. “Light-duty” ..... 125

§ 39037.05. “Low-emission motor vehicle” ..... 125

§ 39037.5. “Medium duty” ..... 125

§ 39038. “Model year” ..... 125

§ 39039. “Motor vehicle” ..... 125

§ 39040. “Motor vehicle pollution control device” ..... 125

§ 39041. “Motorcycle” ..... 125

§ 39042. “New motor vehicle” ..... 125

§ 39042.5. “New motor vehicle engine” ..... 126

§ 39046. “Passenger vehicle” ..... 126

§ 39053. “State Board” ..... 126

§ 39058. “Used motor vehicle” ..... 126

§ 39059. “Vehicle” ..... 126

§ 39060. “Vehicular sources” ..... 126

PART 2. State Air Resources Board

Chapter 3. General Powers and Duties

§ 39602. Designated air pollution control agency; Compliance with federal law ..... 126

PART 3. Air Pollution Control Districts

Chapter 4. Bay Area Air Quality Management District

Article 3. Governing Body

§ 40221.5. Members of board ..... 126

Chapter 11. Sacramento Metropolitan Air Quality Management District

Article 7. Financial Provisions ..... 127

§ 41081. (First of two; Repealed January 1, 2024) Surcharge on vehicle registration fees ..... 127

§ 41081. (Second of two; Operative January 1, 2024) Surcharge on vehicle registration fees ..... 127

PART 5. Vehicular Air Pollution Control

Chapter 1. General Provisions

§ 43012. Right of entry for inspection; Notice to correct; Display of disclosure; Civil penalties ..... 128

§ 43013. Adoption of standards to carry out purposes of division ..... 129

§ 43013.2. Variances from state board’s gasoline specifications ..... 130

Chapter 2. New Motor Vehicles

Article 1. General Provisions ..... 130

§ 43104. Test procedures ..... 130

§ 43105.5. Adoption of regulations regarding requirements for motor vehicle manufacturers; Trade secrets; Compliance ..... 131

Article 1.5. Prohibited Transactions ..... 132

§ 43150. Legislative findings and declarations ..... 132

§ 43151. Acquisition of vehicle or engine outside of state ..... 132

§ 43152. Acquisition of non-certified vehicle or engine for sale or resale ..... 133

TABLE OF CONTENTS

§ 43153. Sale or lease of non-certified vehicle or engine..... 133

§ 43154. Action for civil penalty..... 133

§ 43155. Action for civil penalty; Precedence..... 133

§ 43156. Presumption as to transfer of title based on odometer reading..... 133

Article 2. Manufacturers and Dealers ..... 133

§ 43204. Warranty; “Useful life” ..... 133

§ 43205. Warranty requirements for light and medium duty motor vehicles ..... 134

§ 43205.5. Warranty for motor vehicles other than light and medium duty ..... 134

§ 43210.5. Emissions-related defects ..... 134

Chapter 3. Used Motor Vehicles

Article 3. Heavy-Duty Motor Vehicles ..... 134

§ 43700. Legislative findings and declarations..... 134

§ 43701. Adoption of regulations; Emissions standards and procedures; Compliance by fleet; Evidence that engine met federal standards at time of manufacture ..... 134

Chapter 4. Miscellaneous

Article 1. Low-Emission Motor Vehicles ..... 135

§ 43800. (First of two; Operative date contingent; Operative term contingent) “Low-emission motor vehicle” ..... 135

§ 43800. (Second of two; Operative date contingent) “Low-emission motor vehicle” ..... 135

§ 43801. Legislative finding and declaration ..... 136

§ 43802. Identification and labeling of low-emission motor vehicles; Exemptions from sales and use taxes ..... 136

§ 43804. Purchase by state ..... 136

Article 4. Alcohol Fueled Motor Vehicles ..... 136

§ 43843. Methanol-gasoline experimental vehicle fleet program ..... 136

Chapter 5. Motor Vehicle Inspection Program

Article 1. General..... 137

§ 44000. Legislative declaration of intent ..... 137

§ 44000.1. Legislative intent ..... 137

§ 44000.5. Intent ..... 137

§ 44001. Legislative findings and declarations..... 137

§ 44001.1. Legislative findings and declarations; Legislative intent ..... 138

§ 44001.3. Legislative findings and declarations..... 139

§ 44001.5. Duties of Bureau of Automotive Repair ..... 139

§ 44002. Authority of department and employees; Requirements governing inspections and repairs ..... 139

§ 44003. Enhanced vehicle inspection and maintenance program; Procedures and equipment; Requests for implementation ..... 139

§ 44003.5. Enhanced Motor Vehicle Inspection and Maintenance program Established..... 140

§ 44004. Program to supersede other programs; Inapplicability of provisions ..... 140

§ 44005. Components of program; Frequency of inspection..... 140

Article 2. Program Requirements..... 140

§ 44010. Provisions for smog check stations ..... 141

§ 44010.5. Program for testing specified percentage of state vehicle fleet at test-only facilities; Testing at smog check stations; Contractors; Public education; Implementation areas ..... 141

§ 44011. Certificate of compliance or noncompliance; Exceptions ..... 142

§ 44011.1. “Registered” ..... 143

§ 44011.3. Pretesting ..... 143

§ 44011.5. Proof of exemption requirements..... 143

§ 44011.6. Test for smoke emissions; Advisory committee; Regulation and inspection; Criteria for compliance; Penalties; Administrative hearing ..... 143

§ 44012. Tests required at smog check stations ..... 145

§ 44012.1. Visible smoke test ..... 145

§ 44013. (First of three; Operative date contingent) Prescription of maximum emission standards and test procedures..... 145

§ 44013. (Second of three; Operative date contingent; Operative term contingent) Prescription of maximum emission standards and test procedures..... 146

§ 44013. (Third of three; Operative date contingent) Prescription of maximum emission standards and test procedures ..... 146



## TABLE OF CONTENTS

§ 44013.5.	(Operative date contingent; Operative term contingent) Certification of emissions retrofit device installations .....	147
§ 44014.	Smog check stations and technicians; Licensing and qualifications; Provision for referee services; Fees.....	147
§ 44014.2.	Certification program .....	148
§ 44014.4.	Advertisement .....	148
§ 44014.5.	Test-only facilities; Standards .....	148
§ 44014.6.	Inspection-based performance standards; Criteria; Applicability .....	150
§ 44014.7.	Required receipt of certificate from test-only station .....	150
§ 44015.	Certification of certain vehicles prohibited; Issuance of certificates; Repair cost waivers; Economic hardship extensions; Responsibility of licensed motor vehicle dealers .....	150
§ 44015.5.	Certificate of compliance; Certificate of noncompliance .....	151
§ 44016.	Specifications and procedures .....	151
§ 44017.	Cost limitations; Repair cost waiver; Failure to pass visible smoke test.....	151
§ 44017.1.	“Low-income motor vehicle owner”; Repair cost limit; Issuance of economic hardship extension .....	151
§ 44017.3.	Information required to be posted at smog check stations .....	152
§ 44017.4.	Inspection of specially constructed vehicles .....	152
§ 44017.5.	Alternative work day schedule at referee stations .....	152
§ 44018.	Advisory safety and fuel efficiency checks; Exemptions .....	152
§ 44019.	Certificates of compliance for public agency vehicles .....	152
§ 44020.	Testing and servicing of fleet vehicles by fleet owner; Conditions; Initial and renewal license fees .....	153
§ 44024.	New technologies .....	153
§ 44024.5.	Statistical and emissions profiles and data of vehicles; Report; Pilot program to except vehicles from biennial certification requirement.....	154
§ 44025.	Department as vendor clearinghouse.....	154
Article 3.	Quality Assurance .....	154
§ 44030.	Development of standards for licensing of smog check stations .....	155
§ 44030.5.	Standards for certification of institutions and instructors .....	155
§ 44031.5.	Qualification and licensing requirements for smog check technicians .....	155
§ 44032.	Prerequisites to performing tests and repairs.....	155
§ 44033.	Authorization and requirements of license facilities; Limitations .....	155
§ 44034.	Annual license fees .....	156
§ 44034.1.	Examination fee for technician initial and renewal license .....	156
§ 44035.	Suspension or revocation of license; Hearing .....	156
§ 44036.	Referee stations; Certification of test equipment.....	156
§ 44036.1.	Manufacturers’ proof of financial security.....	157
§ 44036.2.	Manufacturers to provide information on emission control system service .....	158
§ 44036.3.	Department to direct smog check stations and technicians to information sources .....	158
§ 44036.5.	Test analyzer system calibration gases; Gas blenders.....	159
§ 44036.8.	Use of smog check data when appealing Bureau of Automotive Repair citation .....	159
§ 44037.	Records of tests and repairs; Contents.....	159
§ 44037.1.	Centralized computer data base and network; Transmission of emission test results to data base .....	159
§ 44037.2.	Data base .....	160
§ 44038.	Transmission of data to department .....	160
§ 44039.	Publication of information summary.....	160
§ 44040.	Certificates of compliance and noncompliance and repair cost waivers.....	160
§ 44041.	Bar code labels.....	160
§ 44045.5.	Qualifications to be met by smog check technician applicants; Categories and levels of licensure; Renewal.....	160
§ 44045.6.	Requirements for training of smog check technicians; Certification by established national training institution; Remedial training .....	161
Article 4.	Penalties .....	161
§ 44050.	Remedies; Penalties; Issuance of citation; Administrative fine; Considerations; Order of abatement; Form of citation; Failure to comply with order; Adoption of regulations; Deposit of fines.....	161
§ 44051.	Contested citation; Hearing; Informal citation conference.....	162
§ 44052.	Civil penalty for separate violations.....	162
§ 44055.	Nonrenewal of license for failure to pay civil penalty or administrative fine .....	162
§ 44056.	Violations; Penalties; Exceptions.....	162

TABLE OF CONTENTS

§ 44057. Injunctions and restraining orders against violations ..... 163

§ 44058. Violations as misdemeanors ..... 163

§ 44059. Perjury ..... 163

Article 5. Financial Provisions ..... 163

    § 44060. Certificates of compliance or noncompliance, repair cost waivers and economic hardship extensions; Form; Issuance; Fee ..... 163

    § 44060.5. (Repealed January 1, 2024) Smog abatement fee increase; Distribution of revenues ..... 164

    § 44061. Deposit and use of fees ..... 164

    § 44062. Abolishment of Vehicle Inspection and Automotive Repair Funds ..... 164

    § 44062.1. Low-income repair assistance program; Eligibility; Funding; Copayment; Data collection ..... 164

    § 44062.2. (First of two; Operative date contingent; Operative term contingent) Emission credit exchange program; Marketable emission reduction credits ..... 165

    § 44062.2. (Second of two; Operative date contingent) Emission credit exchange program; Marketable emission reduction credits ..... 165

    § 44062.3. Retiring of vehicle that has failed smog check inspection ..... 166

    § 44063. Transfer of litigation funds to Vehicle Inspection and Repair Fund ..... 166

Article 6. Public Information ..... 166

    § 44070. Public information program ..... 166

    § 44070.5. Public information program inclusions ..... 166

    § 44071. Funding ..... 166

Article 7. Denial, Suspension, and Revocation ..... 167

    § 44072. Suspension or revocation of license ..... 167

    § 44072.1. Grounds for denial of license ..... 167

    § 44072.2. Grounds for suspension, revocation, or disciplinary action against license ..... 167

    § 44072.3. What constitutes conviction ..... 167

    § 44072.4. Types of disciplinary action ..... 167

    § 44072.5. Surrender of license ..... 168

    § 44072.6. Jurisdiction to proceed with investigation of or action against licensee ..... 168

    § 44072.7. Limitations period ..... 168

    § 44072.8. Revocation or suspension of additional license ..... 168

    § 44072.9. Reinstatement of license ..... 168

    § 44072.10. Temporary suspension of license; Grounds; Fraudulent certification; Hearing and notice ..... 168

    § 44072.11. Refusal to issue or renew license; Revocation or suspension of license ..... 168

Article 8. Gross Polluters ..... 169

    § 44080. Legislative findings and declarations ..... 169

    § 44081. Identification of gross polluters ..... 169

    § 44081.6. Pilot demonstration program regarding emissions ..... 170

    § 44084. Gross polluters whose emissions could be reduced by repair; Financial incentives ..... 171

    § 44085. Marketable emission reduction credits ..... 171

    § 44086. Cost effectiveness of programs ..... 171

Article 9. Repair or Removal of High Polluters ..... 171

    § 44090. Definitions ..... 171

    § 44091. High Polluter Repair or Removal Account; Source of funds; Reserves; Use of funds ..... 171

    § 44091.1. Increase in smog abatement fee for certain exempt vehicles if smog impact fee is uncollectible; Allocation of revenues ..... 172

    § 44091.2. Intent as to impact fee ..... 172

    § 44092. High polluter repair or removal program ..... 172

    § 44093. Repair of high polluters ..... 172

    § 44094. Participation in high polluter repair or removal program; Contents of program ..... 172

    § 44095. Administration of program ..... 172

    § 44096. Cost-effectiveness of emissions reduction devices for light-duty vehicles ..... 173

    § 44099. [Section repealed 2014.] ..... 173

Article 10. Accelerated Light-Duty Vehicle Retirement Program ..... 173

    § 44100. Legislative findings and declarations ..... 173

    § 44101. Statewide program ..... 174

    § 44102. Coordination of requirements and implementation by state agencies ..... 174

    § 44103. Objectives of program ..... 174

    § 44104. Funding for program ..... 175

TABLE OF CONTENTS

§ 44104.5. Plan for first two years of program; Progress report ..... 175

§ 44105. State oversight agency ..... 176

§ 44106. Provisions for tampering and fraud..... 176

§ 44107. Discouragement of tampering and fraud..... 176

§ 44109. Solicitation of vehicle owners ..... 176

§ 44115. Convenience of vehicle purchase transactions ..... 176

§ 44120. Vehicle disposal..... 176

§ 44121. Standards for certification and use of emission reduction credits ..... 176

§ 44122. Measurement of emission reductions..... 176

Article 11. Enhanced Fleet Modernization Program ..... 176

§ 44125. Voluntary retirement of high-polluting vehicles; Guidelines ..... 177

§ 44126. Enhanced Fleet Modernization Subaccount..... 177

Chapter 7. District Fees to Implement the California Clean Air Act

§ 44225. (First of two; Repealed January 1, 2024) Conditions for increase in fee..... 178

§ 44225. (Second of two; Operative January 1, 2024) Conditions for increase in fee ..... 178

§ 44229. (First of two; Repealed January 1, 2024) Distribution of revenues; Limitations on administrative costs ..... 178

§ 44229. (Second of two; Operative January 1, 2024) Distribution of revenues; Limitations on administrative costs..... 179

Chapter 9. Carl Moyer Memorial Air Quality Standards Attainment Program

Article 1. Definitions ..... 179

§ 44275. (First of two; Repealed January 1, 2024) Definitions ..... 179

§ 44275. (Second of two; Operative January 1, 2024) Definitions ..... 180

Article 2. Program Introduction ..... 180

§ 44280. (First of two; Repealed January 1, 2024) Creation of program ..... 180

§ 44280. (Second of two; Operative January 1, 2024) Creation of program..... 181

Article 3. Eligible Projects and Applicants ..... 181

§ 44281. (First of two; Repealed January 1, 2024) Eligible projects and applicants ..... 181

§ 44281. (Second of two; Operative January 1, 2024) Eligible projects and applicants ..... 181

Article 4. General Eligibility Criteria ..... 182

§ 44282. (First of two; Repealed January 1, 2024) Criteria for projects ..... 182

§ 44282. (Second of two; Operative January 1, 2024) Criteria for projects ..... 183

Article 5. Cost-Effectiveness Criteria..... 183

§ 44283. (First of two; Repealed January 1, 2024) Cost-effectiveness criteria ..... 183

§ 44283. (Second of two; Operative January 1, 2024) Cost-effectiveness criteria ..... 184

Article 8. Program Administration: General ..... 185

§ 44287. (First of two; Repealed January 1, 2024) Grant criteria and guidelines; Reservation of funds..... 185

§ 44287. (Second of two; Operative January 1, 2024) Grant criteria and guidelines; Reservation of funds ..... 186

Article 14. Funds ..... 187

§ 44299.1. (First of two; Repealed January 1, 2024) Segregation and administration of fund; Allocation of moneys in fund ..... 188

§ 44299.1. (Second of two; Operative January 1, 2024) Segregation and administration of fund; Allocation of moneys in fund ..... 188

§ 44299.2. (Repealed January 1, 2024) Terms and conditions for allocation of funds to local air pollution and air quality management districts ..... 188

INSURANCE CODE

DIVISION 1. General Rules Governing Insurance

PART 1. The Contract

Chapter 1. Classes of Insurance

§ 100. Classes of insurance..... 191

§ 116. Automobile..... 191

§ 116.5. Express warranty warranting motor vehicle lubricant, treatment, fluid, or additive; When not deemed automobile insurance ..... 191

§ 116.6. Warranty of a vehicle protection system ..... 192

TABLE OF CONTENTS

xx

PART 2. The Business of Insurance

Chapter 1. General Regulations

Article 5. Unlawful Referrals ..... 193

    § 750. Unlawful offer or receipt of consideration by claims handlers for referral or procurement of clients; Punishment ..... 193

Article 5.1. Unlawful Practices ..... 193

    § 758. Requirement that repair shop pay for rental vehicle ..... 193

    § 758.5. Requiring automobile to be repaired at specific dealer ..... 193

Chapter 9. Rates and Rating and Other Organizations

Article 10. Reduction and Control of Insurance Rates ..... 194

    § 1861.02. Good Driver Discount Policy; Determination of rates and premiums; Criteria ..... 194

Chapter 12. The Insurance Frauds Prevention Act

Article 2. Bureau of Fraudulent Claims ..... 195

    § 1872.1. [Section repealed 2013.] ..... 195

Article 4.5. Insurer Inspections ..... 195

    § 1874.85. Required inspection ..... 195

    § 1874.86. Reports to the department ..... 195

    § 1874.87. Providing insured with Bill of Rights ..... 196

Article 4.6. Auto Insurance Fraud Crisis Areas ..... 196

    § 1874.90. Declaration of area ..... 196

DIVISION 2. Classes of Insurance

PART 8. Service Contracts

    § 12800. Definitions ..... 196

    § 12805. What agreements not to constitute insurance; Exemptions ..... 197

    § 12810. Who may offer vehicle service contract to purchaser; Fronting company ..... 197

    § 12820. Vehicle service contract form; Filing; Requirements; Certain benefits as insurance ..... 197

    § 12825. Right to cancel; Conditions; Liability; Refund ..... 198

PENAL CODE

Preliminary Provisions

    § 20. To constitute crime there must be unity of act and intent ..... 199

    § 23. Proceeding against person holding license to engage in business or profession; Appearance of state agency ..... 199

PART 1. Of Crimes and Punishments

TITLE 7. Of Crimes Against Public Justice

Chapter 4. Forging, Stealing, Mutilating, and Falsifying Judicial and Public Records and Documents

    § 115. Offering false or forged instruments for filing ..... 199

Chapter 5. Perjury and Subornation of Perjury

    § 118. Perjury defined ..... 199

    § 126. Punishment for perjury ..... 200

    § 127. Subornation of perjury ..... 200

Chapter 6. Falsifying Evidence, and Bribing, Influencing, Intimidating or Threatening Witnesses

    § 131. Willful misrepresentation in connection with investigation relating to corporate securities, commodities, or business activities ..... 200

TITLE 13. Of Crimes Against Property

Chapter 5. Larceny

    § 502. Computer crimes ..... 200

Chapter 10. Crimes Against Insured Property and Insurers

    § 550. Unlawful acts related to claims ..... 203

    § 551. Referral to automotive repair dealer for consideration; Discounts intended to offset deductible ..... 204

PART 2. Of Criminal Procedure

TITLE 11. Proceedings in Misdemeanor and Infraction Cases and Appeals from Such Cases

Chapter 1. Proceedings in Misdemeanor and Infraction Cases

    § 1463.15. Use of certain funds derived from fines imposed for unlawful motor vehicle exhaust discharge to pay for combined inspection and sobriety checkpoint program ..... 205

**PUBLIC RESOURCES CODE**

DIVISION 30. Waste Management

PART 3. State Programs

Chapter 17. California Tire Recycling Act

Article 5. Financial Provisions.....206

    § 42885. (First of two; Repealed January 1, 2024) California tire fee; Tire Recycling Management Fund.....206

    § 42885. (Second of two; Operative January 1, 2024) California tire fee; Tire Recycling Management Fund...206

    § 42889. (First of two; Repealed January 1, 2024) Expenditures from fund .....207

    § 42889. (Second of two; Operative January 1, 2024) Expenditures from fund .....208

**REVENUE AND TAXATION CODE**

DIVISION 2. Other Taxes

PART 1. Sales and Use Taxes

Chapter 3.3. Vehicle Smog Impact Fee

    § 6263. Emission control label..... 209

Chapter 7. Overpayments and Refunds

Article 1. Claim for Refund .....209

    § 6909. Smog fee refunds ..... 209

PART 10. Personal Income Tax

Chapter 3. Computation of Taxable Income

Article 3. Items Specifically Excluded from Gross Income.....209

    § 17139.5. Interest on smog fee refund ..... 209

**VEHICLE CODE<sup>1</sup>**

DIVISION 1. Words and Phrases Defined

    § 108. “Airbrakes” ..... 211

    § 165. “Authorized emergency vehicle” ..... 211

    § 220. “Automobile dismantler” ..... 211

    § 221. Exclusions from term “automobile dismantler”; Requisite forms ..... 212

    § 234. “Business” ..... 212

    § 246. “Certificate of compliance” ..... 212

    § 259. “Collector motor vehicle” ..... 212

    § 260. “Commercial vehicle” ..... 212

    § 285. “Dealer” ..... 212

    § 286. Dealer; Exclusions ..... 213

    § 288. “Declared combined gross weight” ..... 214

    § 289. “Declared gross vehicle weight” ..... 214

    § 295.5. “Disabled person” ..... 214

    § 296. “Distributor” ..... 214

    § 340. “Garage” ..... 214

    § 350. “Gross vehicle weight rating” ..... 214

    § 370. “Legal owner” ..... 214

    § 372. “Lessor” ..... 215

    § 375. “Lighting equipment” ..... 215

    § 385.5. “Low-speed vehicle” ..... 215

    § 400. “Motorcycle” ..... 215

    § 410. “Motor truck” or “motortruck” ..... 215

    § 415. “Motor vehicle” ..... 215

    § 425. “Muffler” ..... 215

    § 426. “New motor vehicle dealer” ..... 215

    § 430. “New vehicle” ..... 216

    § 431. “Nonrepairable vehicle” ..... 216

    § 432. “Nonrepairable vehicle certificate” ..... 216

    § 460. “Owner” ..... 216

    § 465. “Passenger vehicle” ..... 216

    § 471. “Pickup truck” ..... 216

    § 480. “Power brake” ..... 216

TABLE OF CONTENTS

xxii

§ 505.	“Registered owner” .....	216
§ 506.	“Registration year” .....	216
§ 510.	“Repair shop” .....	217
§ 521.5.	“Revived salvage vehicle” .....	217
§ 543.5.	“Salvage vehicle rebuilder” .....	217
§ 580.	“Specially constructed vehicle” .....	217
§ 593.	“Supplemental restraint system” .....	217
§ 615.	“Tow truck”; “Repossessor’s tow vehicle”; “Automobile dismantlers’ tow vehicle” .....	217
§ 665.	“Used vehicle” .....	217
§ 670.	“Vehicle” .....	217
§ 670.5.	“Vehicle frame” .....	217
§ 671.	“Vehicle identification number” .....	217
§ 672.	“Vehicle manufacturer” .....	218
DIVISION 2. Administration		
Chapter 1. The Department of Motor Vehicles		
Article 2. Powers and Duties .....		218
§ 1673.	“Registered owner or lessee” .....	218
§ 1673.2.	Smog fee refund .....	218
§ 1673.4.	Claims for smog fee refunds .....	218
§ 1673.5.	Erroneous payment of smog refund .....	219
§ 1673.6.	False refund claims .....	219
§ 1673.7.	Notice to accompany refund .....	219
Chapter 4. Administration and Enforcement		
Article 1. Lawful Orders and Inspections .....		219
§ 2814.	Combined vehicle inspection and sobriety checkpoint; Funding .....	219
§ 2814.1.	Vehicle inspection checkpoint program; Motorcycle only checkpoints .....	219
Chapter 6. New Motor Vehicle Board		
Article 1. Organization of Board .....		220
§ 3016.	Funding through imposition of fees .....	220
DIVISION 3. Registration of Vehicles and Certificates of Title		
Chapter 1. Original and Renewal of Registration; Issuance of Certificates of Title		
Article 1. Vehicles Subject to Registration .....		220
§ 4000.	Registration required; Exceptions .....	220
§ 4000.1.	Pollution control device; Certificate or statement .....	221
§ 4000.2.	Pollution control compliance certificate for vehicles previously registered outside state .....	221
§ 4000.3.	Biennial certificate of compliance required .....	222
§ 4000.4.	Mandatory registration of vehicles in California .....	222
§ 4000.6.	Registration of commercial vehicle over 10,000 pounds .....	222
§ 4001.	Registration of vehicles exempt from fees .....	222
§ 4002.	Vehicles exempt under permit .....	222
§ 4003.	One-trip permit .....	223
§ 4003.5.	One-trip permit for specified vehicles .....	223
Article 2. Original Registration .....		223
§ 4156.	Temporary permit; Exception .....	223
Article 4. Evidences of Registration .....		223
§ 4463.	Alteration or falsification of evidence of ownership, registration, or identification; Alteration or falsification of plates, placards, stickers; Violation as infraction; Penalty .....	223
Article 6. Refusal of Registration .....		224
§ 4750.1.	Application for model year determination; Referee station inspection; Fee .....	224
Article 8. Special Plates .....		225
§ 5004.	Vehicles of historic value .....	225
Article 8.3. Historic and Special Interest Vehicles .....		225
§ 5050.	Legislative findings and declarations .....	225
§ 5051.	Definitions .....	225
§ 5052.	Storage; Manner of maintenance .....	226

Article 12. Surrender of Registration Documents and License Plates .....	226
§ 5500. Delivery of certificate of ownership, registration card and license plate prior to disassembling vehicle.....	226
§ 5501. Procedures when vehicle is to be dismantled.....	226
§ 5505. Application for registration of salvage or dismantled vehicle.....	226
§ 5506. Certificate of inspection or vehicle verification form.....	227
Chapter 2. Transfers of Title or Interest	
Article 2. Endorsement and Delivery of Documents.....	227
§ 5751.5. Emissions statement; Warning to buyer.....	227
Chapter 6. Registration and Weight Fees	
Article 2. Registration Fees.....	228
§ 9250. Fee for registration of vehicles and trailer coaches; Applicability; Use of money collected.....	228
§ 9250.1. (Repealed January 1, 2024) Increase in registration fee; Use of increase.....	228
§ 9250.2. (First of two; Repealed January 1, 2024) Surcharge on registration fees .....	228
§ 9250.2. (Second of two; Operative January 1, 2024) Surcharge on registration fees.....	229
§ 9250.18. Collection of administrative fees; Transmission of revenues to Vehicle Inspection and Repair Fund.....	229
§ 9255.2. Fee for registration or transfer of ownership.....	229
§ 9257.5. Fee for temporary permit where certificate of compliance required; Deposit.....	229
§ 9258. Fee for one-trip permit.....	229
DIVISION 4. Special Antitheft Laws	
Chapter 5. Motor Vehicle Theft Prevention	
§ 10904. Public education campaign .....	229
DIVISION 5. Occupational Licensing and Business Regulations	
Chapter 3. Automobile Dismantlers	
§ 11515. Total loss salvage vehicles; Duties of insurance company, salvage pool, owner, etc.; Certificate of ownership; Salvage certificate; Punishment for violations; Civil penalty .....	230
Chapter 7. Sale of Automobile Parts	
§ 12000. Investigation and enforcement .....	231
§ 12001. Invoice; Required information .....	231
§ 12002. Defective vehicle parts .....	231
§ 12003. Violation.....	231
Chapter 9. Towing	
§ 12110. Acceptance of gift or compensation from towing service; Referral fees from repair shop.....	231
DIVISION 6. Drivers' Licenses	
Chapter 2. Suspension or Revocation of Licenses	
Article 3. Suspension and Revocation by Department .....	232
§ 13351.85. Suspension for conviction of towing service violation.....	232
Chapter 4. Violation of License Provisions	
§ 14607.6. Forfeiture of motor vehicle driven by driver with suspended or revoked license, or by unlicensed driver .....	232
DIVISION 11. Rules of the Road	
Chapter 10. Removal of Parked and Abandoned Vehicles	
Article 1. Authority to Remove Vehicles.....	235
§ 22651.07. Duties of person charging for towing or storage; Exception; Rights of vehicle owner or agent; Towing Fees and Access Notice; Contents of itemized invoice; Violations.....	235
DIVISION 12. Equipment of Vehicles	
Chapter 1. General Provisions	
§ 24000. References to "department" .....	237
§ 24001. Applicability of provisions.....	237
§ 24003. Operation of vehicle with unlawful lights.....	237
§ 24004. Unlawful operation after notice by officer.....	237
§ 24005. Sale, transfer or installation of unlawful equipment .....	237
§ 24005.5. Uncertified synthetic rope or webbing strap material.....	238
§ 24006. Equipment to bear name or trademark; Instructions regarding lighting equipment.....	238

TABLE OF CONTENTS

§ 24007. Responsibilities of dealer or retail seller of vehicle; Exemptions; Certificate of compliance or noncompliance or statement ..... 238

§ 24007.2. Exhaust emission devices; Free installation for low-income elderly persons ..... 238

§ 24007.5. Responsibility of auctioneer or public agency selling at public auction ..... 238

§ 24007.6. Responsibilities of salvage pool ..... 239

§ 24011.7. Exhaust and noise emission control inspection ..... 239

§ 24012. Compliance with lighting equipment and mounting regulations ..... 239

Chapter 2. Lighting Equipment

Article 1. General Provisions ..... 239

§ 24250. Use of lights during darkness ..... 240

§ 24251. Lighting distance requirement ..... 240

§ 24252. Lighting equipment requirements ..... 240

§ 24253. Taillamps that remain lighted ..... 240

§ 24254. Mounting height ..... 240

§ 24255. Supplementary illuminating system ..... 240

Article 2. Headlamps and Auxiliary Lamps ..... 240

§ 24400. Headlamps on motor vehicles; Use in darkness and inclement weather ..... 240

§ 24401. Dimmed lights on parked or standing vehicles ..... 241

§ 24402. Auxiliary driving and passing lamps ..... 241

§ 24403. Foglamps ..... 241

§ 24404. Spotlamps ..... 241

§ 24405. Maximum number of lamps ..... 241

§ 24406. Multiple beams ..... 241

§ 24407. Upper and lower beam ..... 241

§ 24408. Beam indicator ..... 241

§ 24409. Use of multiple beams ..... 242

§ 24410. Single beams ..... 242

§ 24411. Auxiliary lamps; Off-highway use ..... 242

Article 3. Rear Lighting Equipment ..... 242

§ 24600. Taillamp requirements, generally ..... 242

§ 24601. License plate light ..... 243

§ 24602. Fog taillamps ..... 243

§ 24603. Stoplamp requirements ..... 243

§ 24604. Lamp or flag on load projections ..... 243

§ 24605. Tow trucks and towed vehicles ..... 244

§ 24606. Backup lamps ..... 244

§ 24607. Red reflector requirements ..... 244

§ 24608. Reflector requirements for buses, trailers, housecars, and motortrucks ..... 244

§ 24609. Reflectors on front of vehicle ..... 245

§ 24610. Multiple-unit truck reflectors ..... 245

§ 24611. Exemption from reflector requirements for certain trailers ..... 245

§ 24615. Slow moving vehicle emblem ..... 245

§ 24616. Equipping vehicle with rear-facing auxiliary lamps ..... 245

Article 4. Parking Lamps ..... 245

§ 24800. Use of parking lamps ..... 246

§ 24801. When lights need not be displayed ..... 246

§ 24802. Use of parking lamps ..... 246

Article 5. Signal Lamps and Devices ..... 246

§ 24950. Turn signal system on vehicle towing trailer ..... 246

§ 24951. Lamp-type turn signal system; Requirements ..... 246

§ 24952. Turn signal visibility requirements ..... 246

§ 24953. Turn signal lamps ..... 246

Article 6. Side and Fender Lighting Equipment ..... 246

§ 25100. Clearance and side-marker lamps ..... 247

§ 25100.1. Clearance and side-marker lamps; Ambulances ..... 247

§ 25102. Lamps on sides of vehicles ..... 247

§ 25102.5. Use of lamps on side of schoolbus when visibility reduced ..... 248

§ 25103. Projecting loads ..... 248



## TABLE OF CONTENTS

§ 25104.	Wide vehicles .....	248
§ 25105.	Courtesy lamps; Door-mounted lamps or reflectors; Exterior lamps .....	248
§ 25106.	Fender lamps; Side lamps .....	248
§ 25107.	Cornering lamps on fenders .....	248
§ 25108.	Turn signal pilot indicators .....	248
§ 25109.	Running lamps .....	249
§ 25110.	Utility flood or loading lamps .....	249
Article 7.	Flashing and Colored Lights .....	249
§ 25250.	General rule on use of flashing lights .....	250
§ 25251.	When flashing lights permitted .....	250
§ 25251.1.	Implements of husbandry; Use of turn signals as warning lights .....	250
§ 25251.2.	Flashing lights on motorcycles .....	250
§ 25251.3.	Civil liability based on use or nonuse of turn signals .....	250
§ 25251.4.	Theft alarm systems .....	250
§ 25251.5.	Deceleration warning lights .....	250
§ 25252.	Warning lights on authorized emergency vehicles .....	251
§ 25252.5.	Flashing headlamps on authorized emergency vehicles .....	251
§ 25253.	Warning lights on tow trucks; Exception on freeway .....	251
§ 25254.	Warning lights on vehicles operated by personnel of marshal's department .....	251
§ 25256.	Warning lights on highway maintenance vehicles .....	251
§ 25257.	School bus signal lights; "Stop signal arm" .....	251
§ 25257.2.	Warning lights on school buses used to transport developmentally disabled persons .....	251
§ 25257.5.	Backup warning by school buses .....	251
§ 25258.	Flashing signal controlling or blue lights for use on authorized emergency vehicles only .....	252
§ 25259.	Additional warning lights on authorized emergency vehicles .....	252
§ 25259.5.	Warning lights on Red Cross emergency or disaster service vehicles .....	252
§ 25260.	Warning lights on public utility vehicles .....	252
§ 25260.1.	Warning lights on vehicles engaged in construction, removal, or inspection of oil or gas pipeline .....	252
§ 25260.3.	Warning lights on vehicle with personnel aerial lift .....	252
§ 25260.4.	Warning lights on hazardous substance spill response vehicles .....	252
§ 25261.	Warning lights on county vehicles engaged in weed control or pest detection .....	252
§ 25262.	Red lights on armored cars .....	253
§ 25263.	Warning lights on house towing trucks .....	253
§ 25264.	Warning lights on coroner vehicles .....	253
§ 25265.	Warning lights on sanitation district repair vehicles .....	253
§ 25266.	Warning lights on vehicles engaged in aqueduct, levee, or stream measurement work .....	253
§ 25267.	Warning lights on pest abatement vehicles .....	253
§ 25268.	Improper use of flashing amber warning light .....	253
§ 25269.	Improper use of red warning light .....	253
§ 25270.	Warning lights on pilot cars and related vehicles .....	253
§ 25270.5.	Warning lights on vehicles herding livestock .....	253
§ 25271.	Warning lights on pet ambulances .....	253
§ 25271.5.	Warning lights on vehicles used for enforcing animal control laws .....	253
§ 25272.	Warning lights on rural mail vehicles .....	254
§ 25273.	Warning lights on school district vehicles .....	254
§ 25274.	Warning lights on cable television vehicle .....	254
§ 25275.	Warning lamp on trucks with long loads .....	254
§ 25275.5.	Buses; Crime alarm lights .....	254
§ 25276.	Warning lights on vehicles transporting persons with intellectual or physical disabilities .....	254
§ 25277.	Warning lights on vehicles enforcing parking laws .....	254
§ 25278.	Warning lights on vehicle owned or operated by land surveyor or civil engineer .....	254
§ 25279.	Warning lights on private security vehicles .....	254
§ 25280.	Warning lights on garbage collection vehicles .....	255
§ 25281.	Display of flashing amber warning lights by privately owned or operated water tender vehicle .....	255
§ 25282.	Amber warning lights .....	255
Article 8.	Warning Lights and Devices .....	255
§ 25300.	Emergency reflectors .....	255

TABLE OF CONTENTS

§ 25301. Use of warning devices on utility and public utility vehicles..... 256

§ 25305. Use of fusees ..... 256

Article 9. Commercial and Common Carrier Vehicles..... 256

§ 25350. Identification lamps and signs; Passenger common carrier motor vehicle..... 256

§ 25351. Identification lamps ..... 256

§ 25352. Traffic control signal changing devices ..... 257

§ 25353. Required conditions for equipping public transit buses with illuminated signs ..... 257

§ 25353.1. (Repealed January 1, 2017) Illuminated advertising signs on City of Santa Monica public transit buses; Definitions..... 257

Article 10. Diffused Lights..... 258

§ 25400. Lighting requirements ..... 258

§ 25401. Diffused lights resembling signs ..... 258

Article 11. Acetylene Lamps ..... 258

§ 25450. Acetylene lamps..... 258

§ 25451. Motorcycles ..... 258

§ 25452. Glaring light ..... 258

Article 12. Reflectorizing Material ..... 258

§ 25500. Use of reflectorizing material ..... 258

Article 13. Headlamps on Motorcycles and Motor-Driven Cycles..... 258

§ 25650. Headlights on motorcycles ..... 259

§ 25650.5. Headlamps on motorcycles manufactured after January 1, 1978; Emergency vehicles ..... 259

§ 25651. Headlamps on motor-driven cycles ..... 259

Article 14. Vehicles Exempted ..... 259

§ 25800. Special mobile equipment ..... 259

§ 25801. Special construction and maintenance equipment ..... 259

§ 25802. Vehicles incidentally operated over highway..... 259

§ 25803. Lamps on other vehicles operated during darkness ..... 260

§ 25804. Lighting equipment on historical vehicles ..... 260

§ 25805. Lamps on forklift trucks ..... 260

§ 25806. Ambulances and firetrucks used for demonstration purposes; Delivery of vehicles to purchaser ..... 260

Article 15. Light Restrictions and Mounting ..... 260

§ 25950. Color of lamps and reflectors; Exceptions ..... 260

§ 25951. Direction of beam ..... 261

§ 25952. Lamps and reflectors on loads ..... 261

Article 16. Equipment Testing..... 261

§ 26100. Safety glazing material ..... 261

§ 26101. Definitions to govern construction of division..... 261

§ 26102. Prospective effect of regulations ..... 261

§ 26103. Adoption and enforcement of regulations; Federal Motor Vehicle Safety Standard..... 261

§ 26104. Requirement of laboratory test data; Proof of compliance ..... 261

Chapter 3. Brakes

Article 1. Brake Requirements ..... 262

§ 26301. Power brake requirements..... 262

§ 26301.5. Emergency brake systems ..... 262

§ 26302. Trailers and semitrailers ..... 262

§ 26303. Trailer coaches and camp trailers ..... 262

§ 26304. Breakaway brakes..... 262

§ 26305. Auxiliary dolly or tow dolly brakes..... 262

§ 26307. Forklift truck brakes ..... 262

§ 26311. Service brakes on all wheels; Exceptions ..... 262

Article 2. Operation of Brakes ..... 263

§ 26450. Service brake and parking brake systems ..... 263

§ 26451. Parking brake requirements..... 263

§ 26452. Brakes after engine failure ..... 263

§ 26453. Condition of brakes ..... 263

§ 26454. Control and stopping requirements..... 263

§ 26455.	Determination of vehicle weight.....	263
§ 26456.	Stopping tests.....	264
§ 26457.	Exemptions.....	264
§ 26458.	Brake requirements for towing vehicles.....	264
§ 26458.5.	Use of additional control.....	264
Article 3.	Airbrakes.....	264
§ 26502.	Adjustment and use of special devices.....	264
§ 26503.	Safety valve.....	264
§ 26504.	Air governor.....	264
§ 26505.	Pressure gauge.....	264
§ 26506.	Warning device.....	265
§ 26507.	Check valve.....	265
§ 26508.	Emergency stopping system.....	265
Article 4.	Vacuum Brakes.....	266
§ 26520.	Vacuum gauge.....	266
§ 26521.	Warning device.....	266
§ 26522.	Check valve.....	266
Chapter 4.	Windshields and Mirrors	
§ 26700.	Windshields.....	267
§ 26701.	Safety glazing material.....	267
§ 26703.	Replacement of glazing material.....	267
§ 26704.	“Safety glazing material”.....	267
§ 26705.	Motorcycle windshields.....	267
§ 26706.	Windshield wipers.....	267
§ 26707.	Condition and use of windshield wipers.....	267
§ 26708.	Material obstructing or reducing driver’s view; Exceptions.....	267
§ 26708.2.	Sun screening devices.....	269
§ 26708.5.	Transparent materials; Tinted safety glass.....	269
§ 26708.7.	Vehicle used by peace officers in performance of duties; Use of window tinting or glazing.....	269
§ 26709.	Mirrors.....	269
§ 26710.	Defective windshields and rear windows.....	270
§ 26711.	Eyeshades for bus or trolley operators.....	270
§ 26712.	Defroster required.....	270
Chapter 5.	Other Equipment	
Article 1.	Horns, Sirens, and Amplification Devices.....	270
§ 27000.	Horns; Backup device or alarm and video camera on garbage trucks.....	270
§ 27002.	Sirens.....	270
§ 27003.	Sirens on armored cars.....	270
Article 2.	Exhaust Systems.....	271
§ 27150.	Adequate muffler requirement; Off-highway vehicles.....	271
§ 27150.1.	Sale of exhaust systems; Compliance with regulations and standards.....	271
§ 27150.2.	Certificates of compliance; Fee; Exemptions.....	271
§ 27150.5.	Sale of non-complying exhaust system.....	271
§ 27150.7.	Dismissal of prosecution.....	271
§ 27151.	Modification of exhaust systems.....	272
§ 27153.	Exhaust products.....	272
§ 27156.	Air pollution control devices; Gross polluters.....	272
§ 27156.1.	Auxiliary gasoline fuel tanks.....	272
§ 27156.2.	Exemption for emergency vehicles.....	272
§ 27156.3.	Vehicles exempt from pollution control device requirements.....	273
§ 27157.	Vehicle pollution emission regulations.....	273
§ 27158.	Certificates of compliance; Vehicle inspection.....	273
§ 27158.5.	Certificate of compliance or inspection; 1955 through 1965 model year motor vehicles.....	273
§ 27159.	Storage of vehicle on request of State Air Resources Board.....	273
Article 2.5.	Noise Limits.....	273
§ 27201.	Pre-1970 motorcycle limit.....	273
§ 27202.	Motorcycle limits.....	273
§ 27202.1.	Environmental protection agency exhaust system label required; Violations; Penalties.....	274

TABLE OF CONTENTS

§ 27204. Applicable limits within specified manufacturer’s gross vehicle weight rating and date of manufacture ..... 274

§ 27206. Limits for other vehicles ..... 274

Article 3. Safety Belts and Inflatable Restraint Systems..... 274

§ 27302. Sale of seatbelts..... 274

§ 27317. Vehicle’s computer system or supplemental restraint system; Previously deployed air bag or components; Violations; Punishment ..... 274

Article 4. Tires ..... 274

§ 27450. Thickness of solid tire ..... 275

§ 27451. Measurement of solid tire ..... 275

§ 27452. Condition of solid tire ..... 275

§ 27455. Inner tubes ..... 275

§ 27460.5. Sale of recut or regrooved tires ..... 275

§ 27461. Use of recut or regrooved tires ..... 275

§ 27465. Tread depth of pneumatic tires ..... 275

§ 27500. Pneumatic tire standard regulations ..... 275

§ 27501. Pneumatic tires not conforming to regulations..... 275

§ 27502. Sale of tires not conforming to noise standards..... 276

§ 27503. Adoption of regulations; Noise standards for tires ..... 276

DIVISION 17. Offenses and Prosecution

Chapter 1. Offenses

Article 1. Violation of Code ..... 276

§ 40000.7. Additional misdemeanors ..... 276

DIVISION 18. Penalties and Disposition of Fees, Fines, and Forfeitures

Chapter 1. Penalties

Article 1. Public Offenses..... 277

§ 42001. Punishment for specified infractions and misdemeanors; Bicycle fine schedule ..... 277

§ 42001.2. Violation of motor vehicle exhaust standards; Allocation of revenues collected from fines and forfeitures ..... 277

§ 42001.14. Punishment for disconnecting, modifying, or altering pollution control device; Allocation and use of fines ..... 278

CALIFORNIA CODE OF REGULATIONS

TITLE 10. Investment

Chapter 5. Insurance Commissioner

Subchapter 7.5. Unfair or Deceptive Acts or Practices in the Business Of Insurance

Article 1. Fair Claims Settlement Practices Regulations..... 279

§ 2695.8. Additional Standards Applicable to Automobile Insurance ..... 279

§ 2695.85. Auto Body Repair Consumer Bill of Rights ..... 279

TITLE 13. Motor Vehicles

DIVISION 2. Department of the California Highway Patrol

Chapter 1. Licensed Stations and Muffler Installers

Article 2. Exhaust System Sale and Installation ..... 285

§ 611. Requirements for Certified Systems ..... 285

§ 612. Sale ..... 285

§ 613. Installation ..... 285

Chapter 2. Lighting Equipment

Article 1. Lighting Equipment Subject to Regulation..... 286

§ 620. Scope of Subchapter..... 286

§ 621. Federally Regulated Equipment..... 286

§ 622. Equipment for Which There Is No Federal Regulation ..... 286

§ 623. Definitions..... 286

§ 624. Referenced Publications ..... 287

§ 625. Test Data..... 287

Article 2. Identification Markings ..... 287

§ 630. Permanent Markings ..... 287

§ 631.	Size of Markings.....	287
§ 632.	Model Designation Markings.....	287
§ 633.	Lens Markings.....	288
§ 634.	Sealed Optical Unit Markings.....	288
§ 635.	Aftermarket Housing Markings.....	288
§ 636.	Original Equipment Housing Markings.....	288
§ 637.	Orientation Markings.....	288
Article 3.	Construction Requirements.....	288
§ 640.	Lamp Construction.....	288
§ 641.	Optic Indexing.....	289
§ 642.	Bulbs.....	289
§ 643.	Bulb Sockets.....	289
§ 644.	Translucent Housings.....	289
§ 645.	White Light to Rear.....	289
§ 646.	Lens Rotation and Displacement.....	289
§ 647.	Plastic Materials.....	289
§ 648.	Housing for Optical Units.....	289
Article 5.	Mechanical Test Requirements.....	289
§ 660.	Applicability.....	290
§ 661.	Aiming Adjustment Test.....	290
§ 662.	Corrosion Test.....	290
§ 663.	Dust Test.....	290
§ 664.	Lens Recession Test.....	290
§ 665.	Moisture Test.....	290
§ 666.	Vibration Test.....	290
§ 667.	Warpage Test.....	291
§ 670.	Scope.....	291
§ 671.	General Lighting Equipment.....	291
§ 672.	Aimable Roadlighting Devices.....	291
§ 673.	Cornering Lamps.....	291
§ 674.	Driving Lamps.....	291
§ 675.	Fog Lamps.....	291
§ 676.	Headlamps, Single Filament.....	291
§ 677.	Headlamps, Double Filament.....	291
§ 678.	Motorcycle Headlamps.....	291
§ 679.	Motor-Driven Cycle Headlamps.....	292
§ 680.	Passing Lamps.....	292
§ 681.	School Bus Sidelamps.....	292
§ 682.	School Bus Warning Lamps.....	292
Article 7.	Mounting Requirements.....	292
§ 685.	Installation and Maintenance.....	292
§ 686.	Mounting of Aftermarket Devices.....	292
§ 687.	Mounting of Original Equipment Devices.....	292
§ 688.	Clearance and Sidemarkers Lamps.....	292
§ 689.	Cornering Lamps.....	293
§ 690.	Deceleration Lamps.....	293
§ 690.5.	Driving Lamps.....	293
§ 691.	Fog Lamps.....	293
§ 692.	Headlamps.....	293
§ 693.	Passing Lamps.....	293
§ 694.	Running Lamps.....	293
§ 695.	School Bus Sidelamps.....	293
§ 695.5.	School Bus Strobe Lamp.....	294
§ 696.	School Bus Warning Lamps.....	294
§ 697.	Side-Mounted Turn Signal Lamps.....	294
§ 698.	Supplemental Signal Lamps.....	294
§ 699.	Turn Signal Lamps.....	295
§ 700.	Warning Lamps.....	295

TABLE OF CONTENTS

xxx

Article 9. Auxiliary Driving, Fog, and Passing Lamps ..... 296

    § 710. Scope ..... 296

    § 711. Mechanical Test Requirements ..... 296

    § 712. Photometric Test Requirements ..... 296

    § 713. Beam Aimability Requirements ..... 296

Article 10. Cornering Lamps ..... 296

    § 720. Scope ..... 296

    § 721. Mechanical Test Requirements ..... 296

    § 722. Photometric Test Requirements ..... 297

Article 11. Deceleration Signal Lamp Systems ..... 297

    § 730. Scope ..... 297

    § 731. Operating Requirements ..... 297

Article 12. Fog Taillamps ..... 297

    § 740. Scope ..... 297

    § 741. General Requirements ..... 297

    § 742. Mechanical Test Requirements ..... 297

Article 14. Reflex Reflectors on Front of Vehicles ..... 297

    § 760. Scope ..... 297

    § 761. Definitions ..... 297

    § 762. Test Requirements ..... 297

Article 15. Replacement Lenses ..... 298

    § 765. Scope ..... 298

    § 766. Definition ..... 298

    § 767. Mechanical Test Requirements ..... 298

    § 768. Photometric Test Requirements ..... 298

    § 769. Installation Instructions ..... 298

Article 16. Reserve Lighting and Outage Indicating Systems ..... 298

    § 770. Scope ..... 298

    § 771. Definition ..... 298

    § 772. General Requirements ..... 298

    § 773. Operating Requirements ..... 299

    § 774. Voltage Requirements for Alternate Circuits ..... 299

    § 775. Vibration Test Requirements ..... 299

    § 776. Temperature Test Requirements ..... 299

    § 777. Installation Requirements ..... 299

Article 17. Running Lamps ..... 300

    § 780. Scope ..... 300

    § 781. Minimum Size ..... 300

    § 782. Mechanical Test Requirements ..... 300

Article 18. School Bus Sidelamps ..... 300

    § 785. Scope ..... 300

    § 786. General Requirements ..... 300

Article 19. Side-Mounted and Supplemental Signal Lamps ..... 300

    § 790. Scope ..... 300

    § 791. Definitions ..... 300

    § 792. General Requirements ..... 301

    § 793. Mechanical Test Requirements ..... 301

    § 794. Photometric Test Requirements ..... 301

Article 21. Warning Lamp Flashers ..... 301

    § 800. Scope ..... 301

    § 801. Performance and Durability Requirements ..... 301

    § 802. Thermally Operated Flashers ..... 302

    § 803. Nonthermally Operated Flashers ..... 302

    § 804. Variable Load Flashers ..... 302

Article 22. Warning Lamps ..... 302

    § 810. Scope ..... 302

    § 811. Definitions ..... 302

§ 812.	Classification of Warning Lamps.....	302
§ 813.	General Requirements .....	303
§ 814.	Mechanical Test Requirements.....	303
§ 815.	Temperature and Durability Test Requirements.....	303
§ 816.	Color Requirements .....	303
§ 817.	Photometric Test Requirements .....	304
§ 818.	Type of Warning Lamps Used on Emergency Vehicles and Special Hazard Vehicles .....	307
Article 23.	School Bus Strobe Lamps .....	307
§ 819.	Scope .....	307
§ 820.	School Bus Strobe Lamp .....	307
Chapter 4. Special Equipment		
Article 12.	Brake Equipment .....	307
§ 1060.	Scope of Regulations .....	307
§ 1061.	Air Governor Adjustment .....	308
§ 1062.	Safety Valve Adjustment .....	308
§ 1063.	Load-Controlled Air Pressure Reducing System .....	308
§ 1064.	Wheel-Controlled Air Pressure Reducing System .....	308
§ 1065.	Pressure Controlled Reducing System.....	308
§ 1066.	General Requirements for Load, Wheel, and Pressure Controlled Air Pressure Reducing Systems .....	308
Article 14.	Tires and Rims.....	309
§ 1080.	Scope .....	309
§ 1081.	Definitions.....	309
§ 1082.	New Tire Requirements.....	309
§ 1083.	New Tire Marking .....	309
§ 1084.	Identification Markings on Radial Tire Inner Tubes .....	309
§ 1085.	Tire and Rim Size and Capacity .....	310
§ 1086.	Regrooved Tire Design and Construction.....	311
§ 1087.	Tire Condition and Use .....	311
TITLE 16. Professional and Vocational Regulations		
DIVISION 33. Bureau of Automotive Repair		
Chapter 1. Automotive Repair Dealers and Official Stations and Adjusters		
Article 1.	General Provisions .....	313
§ 3300.	Location of Office.....	313
§ 3301.	Continuation of Existing Regulations .....	313
§ 3302.	Tenses, Gender and Number .....	313
§ 3303.	Definitions.....	313
§ 3303.1.	Public Access to License, Administrative Action, and Complaint Information .....	314
§ 3303.2.	Review of Applications for Licensure, Registration and Certification; Processing Time.....	315
§ 3303.3.	Current Address Required.....	316
§ 3303.4.	Nondiscrimination Clause .....	316
§ 3303.4.1.	Applicant Compliance with PRWORA.....	316
§ 3303.4.2.	Requirements for Licensure for Certain Aliens .....	317
§ 3303.4.3.	PRWORA Verification .....	317
§ 3303.4.4.	No Refund of Application Fee.....	317
Article 2.	Licensing of Official Stations and Adjusters .....	317
§ 3304.	Scope of Regulations .....	317
§ 3305.	Station Performance, Work Area and Adjuster Required .....	317
§ 3306.	Licensing Official Stations; Inspection; Term, Renewal and Replacement of Licenses.....	317
§ 3307.	Display of Licenses and Posting of Prices; Equipment Maintenance; Records.....	318
§ 3308.	Official Station That Stops Operating As an Official Station .....	318
§ 3309.	Official Station Signs.....	319
§ 3310.	Licensing Official Lamp and Brake Adjusters .....	320
Article 3.	Official Lamp Adjusting Stations .....	320
§ 3315.	Classes of Official Lamp Adjusting Stations .....	320
§ 3316.	Lamp Adjusting Station Operation and Equipment Requirements .....	321
Article 4.	Official Brake Adjusting Stations.....	322
§ 3320.	Classes of Official Brake Adjusting Stations.....	322

TABLE OF CONTENTS

xxxii

§ 3321. Brake Adjusting Station Operation and Equipment Requirements ..... 322

Article 5. Official Motor Vehicle Pollution Control Device Installation and Inspection Stations ..... 323

Article 5.5. Motor Vehicle Inspection Program ..... 323

§ 3340.1. Definitions ..... 323

§ 3340.4. Smog Check Referee Services ..... 326

§ 3340.5. Vehicles Exempt from Inspections. .... 327

§ 3340.6. Vehicles Subject to Inspection upon Change of Ownership and Initial Registration in California ..... 327

§ 3340.7. Fee for Inspection at State-Contracted Test-Only Facility ..... 327

§ 3340.8. Economic Hardship Extension ..... 327

§ 3340.9. Repair Assistance Program. .... 328

§ 3340.10. Licensing of Smog Check Stations ..... 328

§ 3340.15. General Requirements for Smog Check Stations ..... 328

§ 3340.16. Test-Only Station Requirements ..... 330

§ 3340.16.4. Repair-Only Station Requirements ..... 330

§ 3340.16.5. Test-and-Repair Station Requirements ..... 331

§ 3340.16.6. Requirement for Telephone Line ..... 331

§ 3340.16.7. Test Equipment and Electronic Transmission Requirements ..... 332

§ 3340.17. Test Equipment, Electronic Transmission, Maintenance and Calibration Requirements. .... 332

§ 3340.17.1. Decertification of Equipment Manufacturers ..... 332

§ 3340.17.2. Citations and Informal Citation Conference ..... 333

§ 3340.18. Certification of Emissions Inspection System Calibration Gases and Blenders of Gases ..... 333

§ 3340.20. Acknowledgment and Waiver Requirement for Licensed Test-and-Repair Stations ..... 333

§ 3340.22. Smog Check Station Signs ..... 333

§ 3340.22.1. Smog Check Station Service Signs ..... 334

§ 3340.22.2. Smog Check Station Repair Cost Limit Sign ..... 334

§ 3340.22.3. Replacement of Signs ..... 334

§ 3340.23. Licensed Smog Check Station That Ceases Operating As a Licensed Station ..... 334

§ 3340.24. Suspension, Revocation, and Reinstatement of Licenses ..... 335

§ 3340.25. Licensing of Inspectors ..... 335

§ 3340.28. Licenses and Qualifications for Smog Check Inspectors and Repair Technicians ..... 335

§ 3340.29. Licensing of Smog Check Inspectors and Repair Technicians ..... 336

§ 3340.30. General Requirements for Smog Check Inspectors and/or Repair Technicians ..... 337

§ 3340.31. Retraining of Licensed Smog Check Inspectors and/or Repair Technicians ..... 337

§ 3340.32. Standards for the Certification of Institutions Providing Retraining to Licensed Technicians or Prerequisite Training to Those Seeking to Become Licensed Technicians ..... 337

§ 3340.32.1. Standards for the Decertification and Recertification of Institutions Providing Retraining to Licensed Technicians or Prerequisite Training to Those Seeking to Become Licensed Technicians ..... 340

§ 3340.33. Standards for the Certification of Basic and Advanced Instructors Providing Retraining to Intern, Basic Area, and Advanced Emission Specialist Licensed Technicians or Prerequisite Training to Those Seeking to Become Intern, Basic Area, or Advanced Emission Specialist Licensed Technicians ..... 340

§ 3340.33.1. Standards for the Decertification and Recertification of Instructors Providing Retraining to Licensed Technicians or Prerequisite Training to Those Seeking to Become Licensed Technicians ..... 341

§ 3340.34. Qualification Levels of Mechanics ..... 342

§ 3340.35. A Certificate of Compliance, Noncompliance, Repair Cost Waiver or an Economic Hardship Extension ..... 342

§ 3340.35.1. A Certificate of Compliance, Noncompliance, Repair Cost Waiver or an Economic Hardship Extension Fee Calculation ..... 342

§ 3340.36. Clearing Enforcement Forms ..... 343

§ 3340.36.1. Fee for Exhaust System Certificate of Compliance ..... 343

§ 3340.37. Installation of Oxides of Nitrogen (NOx) Devices ..... 343

§ 3340.38. Vehicle Registration Amnesty Program [Repealed] ..... 343

§ 3340.41. Inspection, Test, and Repair Requirements ..... 343

§ 3340.41.3. Invoice Requirements ..... 349

§ 3340.41.5. Tampering with Emissions Control Systems ..... 349

§ 3340.42. Smog Check Test Methods and Standards ..... 349

§ 3340.42.1. Mandatory Exhaust Emissions Inspection Standards and Test Procedures for Heavy-Duty Vehicles Powered by Gasoline ..... 355



§ 3340.42.2.	Test Methods and Standards for the On-Board Diagnostic Inspection.....	355
§ 3340.43.	Repair Cost Limit.....	356
§ 3340.45.	Smog Check Manual.....	356
§ 3340.50.	Fleet Facility Requirements.....	357
§ 3340.50.1.	Application for Fleet Facility License; Renewal; Replacement.....	357
§ 3340.50.3.	Fleet Records and Reporting Requirements.....	357
§ 3340.50.4.	Fleet Certificates.....	358
§ 3340.50.5.	Suspension or Rescission of Fleet Facility License.....	358
Article 6.	Registration and Requirements for Automotive Repair Dealers.....	358
§ 3350.	Scope.....	358
§ 3351.	Registration of Automotive Repair Dealers.....	358
§ 3351.1.	Fees.....	358
§ 3351.2.	Renewal of Automotive Repair Dealer Registration.....	359
§ 3351.3.	Display.....	359
§ 3351.4.	Specifications for Automotive Repair Dealer's Sign.....	359
§ 3351.5.	Equipment Requirements for Auto Body Repair Shops.....	361
§ 3351.6.	Equipment Requirements for Automotive Air Conditioning Repair Dealers.....	361
Article 7.	Disclosure Requirements for Automotive Repair Dealers.....	362
§ 3352.	Definitions.....	362
§ 3353.	Written Estimate Required for Repair or Maintenance; Exceeding Estimate; Authorization Required.....	362
§ 3354.	Unusual Circumstances; Authorization Required.....	364
§ 3355.	Replaced Parts That Are Not Returnable.....	364
§ 3356.	Invoice Requirements.....	364
§ 3356.1.	Toxic Waste Disposal Costs.....	364
§ 3357.	Denial, Suspension, and Revocation Substantial Relation Criteria.....	364
§ 3358.	Maintenance of Records.....	365
§ 3359.	Sublet Disclosure.....	365
Article 8.	Accepted Trade Standards.....	365
§ 3360.	Scope of Regulations.....	365
§ 3360.1.	Ball Joints.....	365
§ 3360.2.	General Requirements.....	365
§ 3360.3.	Recommendations Permitted.....	366
§ 3361.1.	Automatic Transmissions.....	366
§ 3362.1.	Engine Changes.....	367
§ 3363.3.	Authorized Installers of Ignition Interlock Devices.....	367
§ 3363.4.	Installation Standards Applicable to Ignition Interlock Devices.....	367
§ 3364.	Vehicle Identification Information.....	368
§ 3365.	Auto Body and Frame Repairs.....	368
§ 3366.	Automotive Air Conditioning.....	368
§ 3367.	Inflatable Restraint Systems; Airbags.....	369
§ 3368.	Commissions, Consideration, Inducements, or Referral Fees; Towing Services.....	369
Article 9.	False or Misleading Statements and Advertising.....	369
§ 3370.	Application of Article.....	369
§ 3371.	Untrue or Misleading Statements or Advertising.....	369
§ 3371.1.	Presumption As Automotive Repair Dealer.....	369
§ 3372.	False or Misleading Defined.....	370
§ 3372.1.	Price Advertising.....	370
§ 3373.	False or Misleading Records.....	370
§ 3374.	New, Rebuilt, Reconditioned, or Used Parts and Components.....	370
§ 3374.1.	Manufacture, Sale, or Installation of Defective Vehicle Parts.....	370
§ 3375.	Guarantees and Warranties.....	370
§ 3376.	Disclosure of Guarantee.....	371
§ 3377.	Pro-Rata Guarantee.....	371
§ 3385.	Display.....	371
§ 3386.	Specifications for Automotive Repair Dealer's Sign.....	371
§ 3390.	Fees.....	371
§ 3391.	Renewal of Automotive Repair Dealer Registration.....	371

TABLE OF CONTENTS

Article 10. Gold Shield Program ..... 371

    § 3392.1. Gold Shield Program (GSP)..... 371

    § 3392.2. Responsibilities of Smog Check Stations Certified as Gold Shield..... 372

    § 3392.2.1. Required Services of STAR Stations ..... 373

    § 3392.3. Eligibility for Gold Shield Certification; Quality Assurance ..... 373

    § 3392.3.1. Eligibility/Performance Standards for STAR Certification ..... 374

    § 3392.4. STAR Program Evaluations ..... 375

    § 3392.5. Causes for Invalidation of Gold Shield Station Certification ..... 375

    § 3392.5.1. Causes for Invalidation of STAR Station Certification ..... 376

    § 3392.6. Gold Shield Program Hearing and Determination..... 376

    § 3392.6.1. STAR Program Hearing and Determination ..... 377

Article 11. Consumer Assistance Program and Enhanced Fleet Modernization Program..... 377

    § 3394.1. Purpose and Components of the Consumer Assistance Program ..... 377

    § 3394.2. Consumer Assistance Program Administration ..... 377

    § 3394.3. State Assistance Limits..... 378

    § 3394.4. Eligibility Requirements..... 378

    § 3394.5. Ineligible Vehicles ..... 379

    § 3394.6. Application and Documentation Requirements for the Consumer Assistance Program ..... 380

    § 3394.7. Application and Documentation Requirements for the Enhanced Fleet Modernization Program ..... 381

Article 11.1. Citations and Administrative Fines for Licensees..... 381

    § 3394.25. Authority to Issue Citations and Administrative Fines..... 381

    § 3394.26. Administrative Fine Amounts ..... 381

    § 3394.27. Compliance with Citations/Orders of Abatement..... 382

Article 11.2. Administrative Citations and Fines for Unlicensed Activity..... 382

    § 3394.40. Authority to Issue Citations and Fines for Unlicensed Practice..... 382

    § 3394.41. Citation Format..... 382

    § 3394.42. Citations for Unlicensed Practice..... 383

    § 3394.43. Fine Amounts for Unlicensed Practice..... 383

    § 3394.44. Compliance with Citation/Order of Abatement ..... 383

    § 3394.45. Contested Citations and Request for a Hearing or Informal Citation Conference..... 384

    § 3394.46. Disconnection of Telephone Service..... 384

Article 12. Miscellaneous..... 384

    § 3395. Criteria for Rehabilitation ..... 384

    § 3395.1. Conditions to Insure Future Compliance ..... 385

    § 3395.2. Criteria for Denial, Suspension, or Revocation of a Registration ..... 385

    § 3395.3. Manufacture, Sale, or Installation of Defective Vehicle Parts ..... 385

    § 3395.4. Disciplinary Guidelines..... 385

DIVISION 33.1. Arbitration Certification Program

Article 1..... 385

    § 3396.1. Definitions..... 385

    § 3397. Scope of Regulations ..... 386

Article 2. Minimum Standards for Manufacturers ..... 387

    § 3397.1. General Duties ..... 387

    § 3397.2. Disclosures by Manufacturer to Consumers ..... 387

    § 3397.3. Resolution of Disputes Directly by Manufacturer ..... 387

    § 3397.4. Manufacturer's Duty to Aid in Investigation ..... 388

    § 3397.5. Manufacturer's Duties Following Decision..... 388

INDEX..... 389

# BUSINESS & PROFESSIONS CODE

## GENERAL PROVISIONS

### Section

- 7.5. "Conviction"; When action by board following establishment of conviction may be taken; Prohibition against denial of licensure; Application of section
- 12.5. Violation of regulation adopted pursuant to code provision; Issuance of citation
22. "Board"
- 23.7. "License"
- 23.8. "Licentiate"
27. Information to be provided on Internet; Entities in Department of Consumer Affairs required to comply
- 29.5. Additional qualifications for licensure
30. Provision of federal employer identification number or social security number by licensee
31. Compliance with judgment or order for support upon issuance or renewal of license

### **§ 7.5. "Conviction"; When action by board following establishment of conviction may be taken; Prohibition against denial of licensure; Application of section**

A conviction within the meaning of this code means a plea or verdict of guilty or a conviction following a plea of nolo contendere. Any action which a board is permitted to take following the establishment of a conviction may be taken when the time for appeal has elapsed, or the judgment of conviction has been affirmed on appeal or when an order granting probation is made suspending the imposition of sentence, irrespective of a subsequent order under the provisions of Section 1203.4 of the Penal Code. However, a board may not deny a license to an applicant who is otherwise qualified pursuant to subdivision (b) of Section 480.

Nothing in this section shall apply to the licensure of persons pursuant to Chapter 4 (commencing with Section 6000) of Division 3.

Added Stats 1979 ch 876 § 1.

### **§ 12.5. Violation of regulation adopted pursuant to code provision; Issuance of citation**

Whenever in any provision of this code authority is granted to issue a citation for a violation of any provision of this code, that authority also includes the authority to issue a citation for the violation of any regulation adopted pursuant to any provision of this code.

Added Stats 1986 ch 1379 § 1.

### **§ 22. "Board"**

"Board," as used in any provision of this code, refers to the board in which the administration of the provision is vested, and unless otherwise expressly provided, shall include "bureau," "commission," "committee," "department," "division," "examining committee," "program," and "agency."

Enacted Stats 1937. Amended Stats 1947 ch 1350 § 1; Stats 1980 ch 676 § 1; Stats 1991 ch 654 § 1 (AB 1893); Stats 1999 ch 656 § 1 (SB 1306); Stats 2004 ch 33 § 1 (AB 1467), effective April 13, 2004; Stats 2010 ch 670 § 1 (AB 2130), effective January 1, 2011.

### **§ 23.7. "License"**

Unless otherwise expressly provided, "license" means license, certificate, registration, or other means to engage in a business or profession regulated by this code or referred to in Section 1000 or 3600.

Added Stats 1994 ch 26 § 1 (AB 1807), effective March 30, 1994.

### **§ 23.8. "Licentiate"**

"Licentiate" means any person authorized by a license, certificate, registration, or other means to engage in a business or profession regulated by this code or referred to in Sections 1000 and 3600.

Added Stats 1961 ch 2232 § 1.

### **§ 27. Information to be provided on Internet; Entities in Department of Consumer Affairs required to comply**

(a) Each entity specified in subdivisions (c), (d), and (e) shall provide on the Internet information regarding the status of every license issued by that entity in accordance with the California Public Records Act (Chapter 3.5 (commencing with Section 6250) of Division 7 of Title 1 of the Government Code) and the Information Practices Act of 1977 (Chapter 1 (commencing with Section 1798) of Title 1.8 of Part 4 of Division 3 of the Civil Code). The public information to be provided on the Internet shall include information on suspensions and revocations of licenses issued by the entity and other related enforcement action, including accusations filed pursuant to the Administrative Procedure Act (Chapter 3.5 (commencing with Section 11340) of Part 1 of Division 3 of Title 2 of the Government Code) taken by the entity relative to persons, businesses, or facilities subject to licensure or regulation by the entity. The information may not include personal information, including home telephone number, date of birth, or social security number. Each entity shall disclose a licensee's address of record. However, each entity shall allow a licensee to provide a post office box number or other alternate address, instead of his or her home address, as the address of record. This section shall not preclude an entity from also requiring a licensee, who has provided a post office box number or other alternative mailing address as his or her address of record, to provide a physical business address or residence address only for the entity's internal administrative use and not for disclosure as the licensee's address of record or disclosure on the Internet.

(b) In providing information on the Internet, each entity specified in subdivisions (c) and (d) shall comply with the Department of Consumer Affairs Guidelines for Access to Public Records.

(c) Each of the following entities within the Department of Consumer Affairs shall comply with the requirements of this section:

(1) The Board for Professional Engineers, Land Surveyors, and Geologists shall disclose information on its registrants and licensees.

(2) The Bureau of Automotive Repair shall disclose information on its licensees, including auto repair dealers, smog stations, lamp and brake stations, smog check technicians, and smog inspection certification stations.

(3) The Bureau of Electronic and Appliance Repair, Home Furnishings, and Thermal Insulation shall disclose information on its licensees and registrants, including major appliance repair dealers, combination dealers (electronic and appliance), electronic repair dealers, service contract sellers, and service contract administrators.

(4) The Cemetery and Funeral Bureau shall disclose information on its licensees, including cemetery brokers, cemetery salespersons, cemetery managers, crematory managers, cemetery authorities, crematories, cremated remains disposers, embalmers, funeral establishments, and funeral directors.

(5) The Professional Fiduciaries Bureau shall disclose information on its licensees.

(6) The Contractors' State License Board shall disclose information on its licensees and registrants in accordance with Chapter 9 (commencing with Section 7000) of Division 3. In addition to information related to licenses as specified in subdivision (a), the board shall also disclose information provided to the board by the Labor Commissioner pursuant to Section 98.9 of the Labor Code.

(7) The Bureau for Private Postsecondary Education shall disclose information on private postsecondary institutions under its jurisdiction, including disclosure of notices to comply issued pursuant to Section 94935 of the Education Code.

(8) The California Board of Accountancy shall disclose information on its licensees and registrants.

(9) The California Architects Board shall disclose information on its licensees, including architects and landscape architects.

(10) The State Athletic Commission shall disclose information on its licensees and registrants.

(11) The State Board of Barbering and Cosmetology shall disclose information on its licensees.

(12) The State Board of Guide Dogs for the Blind shall disclose information on its licensees and registrants.

(13) The Acupuncture Board shall disclose information on its licensees.

(14) The Board of Behavioral Sciences shall disclose information on its licensees, including marriage and family therapists, licensed clinical social workers, licensed educational psychologists, and licensed professional clinical counselors.

(15) The Dental Board of California shall disclose information on its licensees.

(16) The State Board of Optometry shall disclose information regarding certificates of registration to practice optometry, statements of licensure, optometric corporation registrations, branch office licenses, and fictitious name permits of its licensees.

(17) The Board of Psychology shall disclose information on its licensees, including psychologists, psychological assistants, and registered psychologists.

(d) The State Board of Chiropractic Examiners shall disclose information on its licensees.

(e) The Structural Pest Control Board shall disclose information on its licensees, including applicators, field representatives, and operators in the areas of fumigation, general pest and wood destroying pests and organisms, and wood roof cleaning and treatment.

(f) "Internet" for the purposes of this section has the meaning set forth in paragraph (6) of subdivision (f) of Section 17538.

Added Stats 1997 ch 661 § 1 (SB 492). Amended Stats 1998 ch 59 § 1 (AB 969); Stats 1999 ch 655 § 1 (SB 1308); Stats 2000 ch 927 § 1 (SB 1889); Stats 2001 ch 159 § 1 (SB 662); Stats 2003 ch 849 § 1 (AB 1418); Stats 2009 ch 308 § 1 (SB 819), effective January 1, 2010, ch 310 § 1.5 (AB 48), effective January 1, 2010; Stats 2011 ch 381 § 2 (SB 146), effective January 1, 2012, ch 712 § 1 (SB 706), effective January 1, 2012.

### § 29.5. Additional qualifications for licensure

In addition to other qualifications for licensure prescribed by the various acts of boards under the department, applicants for licensure and licensees renewing their licenses shall also comply with Section 17520 of the Family Code.

Added Stats 1991 ch 542 § 1 (SB 1161). Amended Stats 2003 ch 607 § 1 (SB 1077).

### § 30. Provision of federal employer identification number or social security number by licensee

(a) Notwithstanding any other law, any board, as defined in Section 22, and the State Bar and the Bureau of Real Estate shall at the time of issuance of the license require that the licensee provide its federal employer identification number, if the licensee is a partnership, or his or her social security number for all others.

(b) Any licensee failing to provide the federal identification number or social security number shall be reported by the licensing board to the Franchise Tax Board and, if failing to provide after notification pursuant to paragraph (1) of subdivision (b) of Section 19528 of the Revenue and Taxation Code, shall be subject to the penalty provided in paragraph (2) of subdivision (b) of Section 19528 of the Revenue and Taxation Code.

(c) In addition to the penalty specified in subdivision (b), a licensing board may not process any application for an original license unless the applicant or licensee provides its federal employer identification number or social security number where requested on the application.

(d) A licensing board shall, upon request of the Franchise Tax Board, furnish to the Franchise Tax Board the following information with respect to every licensee:

- (1) Name.
- (2) Address or addresses of record.
- (3) Federal employer identification number if the entity is a partnership or social security number for all others.
- (4) Type of license.
- (5) Effective date of license or a renewal.
- (6) Expiration date of license.
- (7) Whether license is active or inactive, if known.
- (8) Whether license is new or a renewal.
- (e) For the purposes of this section:

(1) "Licensee" means any entity, other than a corporation, authorized by a license, certificate, registration, or other means to engage in a business or profession

regulated by this code or referred to in Section 1000 or 3600.

(2) "License" includes a certificate, registration, or any other authorization needed to engage in a business or profession regulated by this code or referred to in Section 1000 or 3600.

(3) "Licensing board" means any board, as defined in Section 22, the State Bar, and the Bureau of Real Estate.

(f) The reports required under this section shall be filed on magnetic media or in other machine-readable form, according to standards furnished by the Franchise Tax Board.

(g) Licensing boards shall provide to the Franchise Tax Board the information required by this section at a time that the Franchise Tax Board may require.

(h) Notwithstanding Chapter 3.5 (commencing with Section 6250) of Division 7 of Title 1 of the Government Code, the social security number and federal employer identification number furnished pursuant to this section shall not be deemed to be a public record and shall not be open to the public for inspection.

(i) Any deputy, agent, clerk, officer, or employee of any licensing board described in subdivision (a), or any former officer or employee or other individual who in the course of his or her employment or duty has or has had access to the information required to be furnished under this section, may not disclose or make known in any manner that information, except as provided in this section to the Franchise Tax Board or as provided in subdivision (k).

(j) It is the intent of the Legislature in enacting this section to utilize the social security account number or federal employer identification number for the purpose of establishing the identification of persons affected by state tax laws and for purposes of compliance with Section 17520 of the Family Code and, to that end, the information furnished pursuant to this section shall be used exclusively for those purposes.

(k) If the board utilizes a national examination to issue a license, and if a reciprocity agreement or comity exists between the State of California and the state requesting release of the social security number, any deputy, agent, clerk, officer, or employee of any licensing board described in subdivision (a) may release a social security number to an examination or licensing entity, only for the purpose of verification of licensure or examination status.

(l) For the purposes of enforcement of Section 17520 of the Family Code, and notwithstanding any other provision of law, any board, as defined in Section 22, and the State Bar and the Bureau of Real Estate shall at the time of issuance of the license require that each licensee provide the social security number of each individual

listed on the license and any person who qualifies the license. For the purposes of this subdivision, "licensee" means any entity that is issued a license by any board, as defined in Section 22, the State Bar, the Bureau of Real Estate, and the Department of Motor Vehicles.

Added Stats 1986 ch 1361 § 1. Amended Stats 1988 ch 1333 § 1, effective September 24, 1988; Stats 1991 ch 542 § 2 (SB 1161), ch 654 § 1.5 (AB 1893); Stats 1994 ch 1135 § 1 (AB 3302); Stats 1997 ch 17 § 1 (SB 947) (ch 604 prevails), ch 604 § 1 (SB 1106), effective October 3, 1997, ch 605 § 1 (AB 1040); Stats 1999 ch 652 § 1.5 (SB 240); Stats 2006 ch 658 § 1 (SB 1476), effective January 1, 2007; Stats 2013 ch 352 § 1 (AB 1317), effective September 26, 2013, operative July 1, 2013.

### § 31. Compliance with judgment or order for support upon issuance or renewal of license

(a) As used in this section, "board" means any entity listed in Section 101, the entities referred to in Sections 1000 and 3600, the State Bar, the Bureau of Real Estate, and any other state agency that issues a license, certificate, or registration authorizing a person to engage in a business or profession.

(b) Each applicant for the issuance or renewal of a license, certificate, registration, or other means to engage in a business or profession regulated by a board who is not in compliance with a judgment or order for support shall be subject to Section 17520 of the Family Code.

(c) "Compliance with a judgment or order for support" has the meaning given in paragraph (4) of subdivision (a) of Section 17520 of the Family Code.

(d) Each licensee or applicant whose name appears on a list of the 500 largest tax delinquencies pursuant to Section 7063 or 19195 of the Revenue and Taxation Code shall be subject to Section 494.5.

(e) Each application for a new license or renewal of a license shall indicate on the application that the law allows the State Board of Equalization and the Franchise Tax Board to share taxpayer information with a board and requires the licensee to pay his or her state tax obligation and that his or her license may be suspended if the state tax obligation is not paid.

(f) For purposes of this section, "tax obligation" means the tax imposed under, or in accordance with, Part 1 (commencing with Section 6001), Part 1.5 (commencing with Section 7200), Part 1.6 (commencing with Section 7251), Part 1.7 (commencing with Section 7280), Part 10 (commencing with Section 17001), or Part 11 (commencing with Section 23001) of Division 2 of the Revenue and Taxation Code.

Added Stats 1991 ch 110 § 4 (SB 101). Amended Stats 1991 ch 542 § 3 (SB 1161); Stats 2010 ch 328 § 1 (SB 1330), effective January 1, 2011; Stats 2011 ch 455 § 1 (AB 1424), effective January 1, 2012; Stats 2013 ch 352 § 2 (AB 1317), effective September 26, 2013, operative July 1, 2013.

## DIVISION 1

### Department of Consumer Affairs

#### CHAPTER 1

#### The Department

Section  
100. Establishment

Section  
101. Composition of department  
101.6. Purpose  
101.7. Meetings of boards; Regular and special  
102. Assumption of duties of board created by initiative  
102.1, 102.2. [Sections repealed 2014.]  
102.3. Interagency agreement to delegate duties of certain repealed

- Section  
boards; Technical committees for regulation of professions under delegated authority; Renewal of agreement
- 103. Compensation and reimbursement for expenses
  - 104. Display of licenses or registrations
  - 105. Oath of office
  - 105.5. Tenure of members of boards, etc., within department
  - 106. Removal of board members
  - 106.5. Removal of member of licensing board for disclosure of examination information
  - 107. Executive officers
  - 107.5. Official seals
  - 108. Status and powers of boards
  - 108.5. Witness fees and expenses
  - 109. Review of decisions; Investigations
  - 110. Records and property
  - 111. Commissioners on examination
  - 112. Publication and sale of directories of authorized persons
  - 113. Conferences; Traveling expenses
  - 114. Reinstatement of expired license of licensee serving in military
  - 114.3. Waiver of fees and requirements for active duty members of armed forces and national guard
  - 115. Applicability of Section 114
  - 115.5. Board required to expedite licensure process for certain applicants; Adoption of regulations
  - 116. Audit and review of disciplinary proceedings; Report to Legislature
  - 117. [Section repealed 1997.]
  - 118. Effect of withdrawal of application; Effect of suspension, forfeiture, etc., of license
  - 119. Misdemeanors pertaining to use of licenses
  - 120. Possession by surviving spouse of canceled certificates
  - 121. Practice during period between renewal and receipt of evidence of renewal
  - 121.5. Application of fees to licenses or registrations lawfully inactivated
  - 122. Fee for issuance of duplicate certificate
  - 123. Conduct constituting subversion of licensing examination; Penalties and damages
  - 123.5. Enjoining violations
  - 124. Manner of notice
  - 125. Misdemeanor offenses by licensees
  - 125.3. Direction to licentiate violating licensing act to pay costs of investigation and enforcement
  - 125.5. Enjoining violations; Restitution orders
  - 125.6. Unlawful discrimination by licensees
  - 125.7. Restraining orders
  - 125.8. Temporary order restraining licensee engaged or about to engage in violation of law
  - 125.9. System for issuance of citations to licensees; Contents; Fines
  - 126. Submission of reports to Governor
  - 127. Submission of reports to director
  - 128. Sale of equipment, supplies, or services for use in violation of licensing requirements
  - 128.5. Reduction of license fees in event of surplus funds
  - 129. Handling of complaints; Reports to Legislature
  - 132. Requirements for institution or joinder of legal action by state agency against other state or federal agency
  - 133. [No section of this number.]
  - 134. Proration of license fees
  - 135. Reexamination of applicants
  - 136. Notification of change of address; Punishment for failure to comply
  - 137. Regulations requiring inclusion of license numbers in advertising, etc.
  - 138. Notice that practitioner is licensed; Evaluation of licensing examination
  - 139. Policy for examination development and validation, and occupational analysis
  - 140. Disciplinary action; Licensee's failure to record cash transactions in payment of employee wages
  - 141. Disciplinary action by foreign jurisdiction; Grounds for disciplinary action by state licensing board
  - 142. Authority to synchronize renewal dates of licenses; Abandonment date for application; Delinquency fee
  - 143. Proof of license as condition of bringing action for collection of compensation
  - 143.5. Provision in agreements to settle certain causes of action prohibited; Adoption of regulations; Exemptions
  - 144. Requirement of fingerprints for criminal record checks; Applicability

**§ 100. Establishment**

There is in the state government, in the Business, Consumer Services, and Housing Agency, a Department of Consumer Affairs.

Enacted Stats 1937. Amended Stats 1969 ch 138 § 5; Stats 1971 ch 716 § 4; Stats 1984 ch 144 § 1. See this section as modified in Governor's Reorganization Plan No. 2 § 1 of 2012. Amended Stats 2012 ch 147 § 1 (SB 1039), effective January 1, 2013, operative July 1, 2013 (ch 147 prevails).

**§ 101. Composition of department**

The department is comprised of the following:

- (a) The Dental Board of California.
- (b) The Medical Board of California.
- (c) The State Board of Optometry.
- (d) The California State Board of Pharmacy.
- (e) The Veterinary Medical Board.
- (f) The California Board of Accountancy.
- (g) The California Architects Board.
- (h) The Bureau of Barbering and Cosmetology.
- (i) The Board for Professional Engineers and Land Surveyors.
- (j) The Contractors' State License Board.
- (k) The Bureau for Private Postsecondary Education.
- (l) The Bureau of Electronic and Appliance Repair, Home Furnishings, and Thermal Insulation.
- (m) The Board of Registered Nursing.
- (n) The Board of Behavioral Sciences.
- (o) The State Athletic Commission.
- (p) The Cemetery and Funeral Bureau.
- (q) The State Board of Guide Dogs for the Blind.
- (r) The Bureau of Security and Investigative Services.
- (s) The Court Reporters Board of California.
- (t) The Board of Vocational Nursing and Psychiatric Technicians.
- (u) The Landscape Architects Technical Committee.
- (v) The Division of Investigation.
- (w) The Bureau of Automotive Repair.
- (x) The Respiratory Care Board of California.
- (y) The Acupuncture Board.
- (z) The Board of Psychology.
- (aa) The California Board of Podiatric Medicine.
- (ab) The Physical Therapy Board of California.
- (ac) The Arbitration Review Program.
- (ad) The Physician Assistant Committee.
- (ae) The Speech-Language Pathology and Audiology Board.
- (af) The California Board of Occupational Therapy.
- (ag) The Osteopathic Medical Board of California.
- (ah) The Naturopathic Medicine Committee.
- (ai) The Dental Hygiene Committee of California.
- (aj) The Professional Fiduciaries Bureau.
- (ak) The State Board of Chiropractic Examiners.
- (al) The Bureau of Real Estate.
- (am) The Bureau of Real Estate Appraisers.
- (an) The Structural Pest Control Board.
- (ao) Any other boards, offices, or officers subject to its jurisdiction by law.

Enacted Stats 1937. Amended Stats 1939 ch 651 § 1; Stats 1947 ch 1350 § 2; Stats 1953 ch 966 § 1; Stats 1955 ch 965 § 1; Stats 1961 ch 1095 § 1; Stats 1968 ch 444 § 1, ch 1323 § 1; Stats 1969 ch 1249 § 5; Stats 1971 ch 716 § 5, ch 1578 § 1, ch 1593 § 23.1, operative July 1, 1973; Stats 1972 ch 749 § 1, ch 1396 § 2; Stats 1973 ch 122 § 2.2, effective June 29, 1973, ch 863 § 1; Stats 1974 ch 546 § 1; Stats 1977 ch 141 § 1, effective June 29, 1977; Stats 1983 ch 150 § 1; Stats 1985 ch 1230 § 1; Stats 1987 ch 925 §

1, effective September 22, 1987; Stats 1989 ch 886 § 1; Stats 1990 ch 1256 § 1 (AB 2649); Stats 1991 ch 359 § 1 (AB 1332), ch 654 § 2 (AB 1893); Stats 1993 ch 1263 § 1 (AB 936); Stats 1994 ch 26 § 3 (AB 1807), effective March 30, 1994, ch 1274 § 1 (SB 2039), ch 1275 § 1 (SB 2101); Stats 1995 ch 60 § 1 (SB 42), effective July 6, 1995; Stats 1997 ch 758 § 1 (SB 1346), ch 759 § 1.5 (SB 827); Stats 1998 ch 59 § 2 (AB 969); Stats 1999 ch 655 § 1.1 (SB 1308); Stats 2000 ch 697 § 1 (SB 1046); Stats 2001 ch 615 § 1 (SB 26), effective October 9, 2001, ch 687 § 1.5 (AB 1409); Stats 2003 ch 485 § 1 (SB 907); Stats 2008 ch 31 § 1 (SB 853), effective January 1, 2009; Stats 2009–2010 4th Ex Sess ch 18 § 1 (AB 20XXXX), effective October 23, 2009; Stats 2009 ch 308 § 2 (SB 819), effective January 1, 2010, ch 309 § 1 (AB 1535), effective January 1, 2010, ch 310 § 2.7 (AB 48), effective January 1, 2010. See this section as modified in Governor's Reorganization Plan No. 2 § 2 of 2012. Amended Stats 2013 ch 352 § 3 (AB 1317), effective September 26, 2013, operative July 1, 2013.

#### § 101.6. Purpose

The boards, bureaus, and commissions in the department are established for the purpose of ensuring that those private businesses and professions deemed to engage in activities which have potential impact upon the public health, safety, and welfare are adequately regulated in order to protect the people of California.

To this end, they establish minimum qualifications and levels of competency and license persons desiring to engage in the occupations they regulate upon determining that such persons possess the requisite skills and qualifications necessary to provide safe and effective services to the public, or register or otherwise certify persons in order to identify practitioners and ensure performance according to set and accepted professional standards. They provide a means for redress of grievances by investigating allegations of unprofessional conduct, incompetence, fraudulent action, or unlawful activity brought to their attention by members of the public and institute disciplinary action against persons licensed or registered under the provisions of this code when such action is warranted. In addition, they conduct periodic checks of licensees, registrants, or otherwise certified persons in order to ensure compliance with the relevant sections of this code.

Added Stats 1980 ch 375 § 1.

#### § 101.7. Meetings of boards; Regular and special

(a) Notwithstanding any other provision of law, boards shall meet at least three times each calendar year. Boards shall meet at least once each calendar year in northern California and once each calendar year in southern California in order to facilitate participation by the public and its licensees.

(b) The director at his or her discretion may exempt any board from the requirement in subdivision (a) upon a showing of good cause that the board is not able to meet at least three times in a calendar year.

(c) The director may call for a special meeting of the board when a board is not fulfilling its duties.

Added Stats 2007 ch 354 § 1 (SB 1047), effective January 1, 2008.

#### § 102. Assumption of duties of board created by initiative

Upon the request of any board regulating, licensing, or controlling any professional or vocational occupation created by an initiative act, the Director of Consumer Affairs may take over the duties of the board under the same conditions and in the same manner as provided in this code for other boards of like character. Such boards

shall pay a proportionate cost of the administration of the department on the same basis as is charged other boards included within the department. Upon request from any such board which has adopted the provisions of Chapter 5 (commencing with Section 11500) of Part 1 of Division 3 of Title 2 of the Government Code as rules of procedure in proceedings before it, the director shall assign hearing officers for such proceedings in accordance with Section 110.5.

Enacted Stats 1937. Amended Stats 1945 ch 869 § 1; Stats 1971 ch 716 § 6.

#### § 102.1. [Section repealed 2014.]

Added Stats 1995 ch 381 § 1 (AB 910), effective August 4, 1995, operative term contingent. Repealed Stats 2013 ch 319 § 1 (SB 822), effective January 1, 2014. The repealed section related to cemetery board and funeral directors and embalmers board not consolidated; succession of duties and powers to Department of Consumer Affairs.

#### § 102.2. [Section repealed 2014.]

Added Stats 1995 ch 381 § 2 (AB 910), effective August 4, 1995. Repealed Stats 2013 ch 319 § 2 (SB 822), effective January 1, 2014. The repealed section related to structural pest control board not in compliance with budget act; succession of duties and powers to department of consumer affairs.

#### § 102.3. Interagency agreement to delegate duties of certain repealed boards; Technical committees for regulation of professions under delegated authority; Renewal of agreement

(a) The director may enter into an interagency agreement with an appropriate entity within the Department of Consumer Affairs as provided for in Section 101 to delegate the duties, powers, purposes, responsibilities, and jurisdiction that have been succeeded and vested with the department, of a board, as defined in Section 477, which became inoperative and was repealed in accordance with Chapter 908 of the Statutes of 1994.

(b)(1) Where, pursuant to subdivision (a), an interagency agreement is entered into between the director and that entity, the entity receiving the delegation of authority may establish a technical committee to regulate, as directed by the entity, the profession subject to the authority that has been delegated. The entity may delegate to the technical committee only those powers that it received pursuant to the interagency agreement with the director. The technical committee shall have only those powers that have been delegated to it by the entity.

(2) Where the entity delegates its authority to adopt, amend, or repeal regulations to the technical committee, all regulations adopted, amended, or repealed by the technical committee shall be subject to the review and approval of the entity.

(3) The entity shall not delegate to a technical committee its authority to discipline a licentiate who has violated the provisions of the applicable chapter of the Business and Professions Code that is subject to the director's delegation of authority to the entity.

(c) An interagency agreement entered into, pursuant to subdivision (a), shall continue until such time as the licensing program administered by the technical committee has undergone a review by the Joint Committee on Boards, Commissions, and Consumer Protection to evaluate and determine whether the licensing program

has demonstrated a public need for its continued existence. Thereafter, at the director's discretion, the inter-agency agreement may be renewed.

Added Stats 1997 ch 475 § 1 (AB 1546). Amended Stats 2004 ch 33 § 2 (AB 1467), effective April 13, 2004.

### § 103. Compensation and reimbursement for expenses

Each member of a board, commission, or committee created in the various chapters of Division 2 (commencing with Section 500) and Division 3 (commencing with Section 5000), and in Chapter 2 (commencing with Section 18600) and Chapter 3 (commencing with Section 19000) of Division 8, shall receive the moneys specified in this section when authorized by the respective provisions.

Each such member shall receive a per diem of one hundred dollars (\$100) for each day actually spent in the discharge of official duties, and shall be reimbursed for traveling and other expenses necessarily incurred in the performance of official duties.

The payments in each instance shall be made only from the fund from which the expenses of the agency are paid and shall be subject to the availability of money.

Notwithstanding any other provision of law, no public officer or employee shall receive per diem salary compensation for serving on those boards, commissions, committees, or the Consumer Advisory Council on any day when the officer or employee also received compensation for his or her regular public employment.

Added Stats 1959 ch 1645 § 1. Amended Stats 1978 ch 1141 § 1; Stats 1985 ch 502 § 1; Stats 1987 ch 850 § 1; Stats 1993 ch 1264 § 1 (SB 574).

### § 104. Display of licenses or registrations

All boards or other regulatory entities within the department's jurisdiction that the department determines to be health-related may adopt regulations to require licensees to display their licenses or registrations in the locality in which they are treating patients, and to inform patients as to the identity of the regulatory agency they may contact if they have any questions or complaints regarding the licensee. In complying with this requirement, those boards may take into consideration the particular settings in which licensees practice, or other circumstances which may make the displaying or providing of information to the consumer extremely difficult for the licensee in their particular type of practice.

Added Stats 1998 ch 991 § 1 (SB1980).

### § 105. Oath of office

Members of boards in the department shall take an oath of office as provided in the Constitution and the Government Code.

Added Stats 1949 ch 829 § 1.

### § 105.5. Tenure of members of boards, etc., within department

Notwithstanding any other provision of this code, each member of a board, commission, examining committee, or other similarly constituted agency within the department shall hold office until the appointment and qualification of his successor or until one year shall have

elapsed since the expiration of the term for which he was appointed, whichever first occurs.

Added Stats 1967 ch 524 § 1.

### § 106. Removal of board members

The Governor has power to remove from office at any time, any member of any board appointed by him for continued neglect of duties required by law, or for incompetence, or unprofessional or dishonorable conduct. Nothing in this section shall be construed as a limitation or restriction on the power of the Governor, conferred on him by any other provision of law, to remove any member of any board.

Enacted Stats 1937. Amended Stats 1945 ch 1276 § 3.

### § 106.5. Removal of member of licensing board for disclosure of examination information

Notwithstanding any other provision of law, the Governor may remove from office a member of a board or other licensing entity in the department if it is shown that such member has knowledge of the specific questions to be asked on the licensing entity's next examination and directly or indirectly discloses any such question or questions in advance of or during the examination to any applicant for that examination.

The proceedings for removal shall be conducted in accordance with the provisions of Chapter 5 of Part 1 of Division 3 of Title 2 of the Government Code, and the Governor shall have all the powers granted therein.

Added Stats 1977 ch 482 § 1.

### § 107. Executive officers

Pursuant to subdivision (e) of Section 4 of Article VII of the California Constitution, each board may appoint a person exempt from civil service and may fix his or her salary, with the approval of the Department of Human Resources pursuant to Section 19825 of the Government Code, who shall be designated as an executive officer unless the licensing act of the particular board designates the person as a registrar.

Enacted Stats 1937. Amended Stats 1984 ch 47 § 2, effective March 21, 1984; Stats 1987 ch 850 § 2. See this section as modified in Governor's Reorganization Plan No. 1 § 1 of 2011. Amended Stats 2012 ch 665 § 1 (SB 1308), effective January 1, 2013.

### § 107.5. Official seals

If any board in the department uses an official seal pursuant to any provision of this code, the seal shall contain the words "State of California" and "Department of Consumer Affairs" in addition to the title of the board, and shall be in a form approved by the director.

Added Stats 1967 ch 1272 § 1. Amended Stats 1971 ch 716 § 7.

### § 108. Status and powers of boards

Each of the boards comprising the department exists as a separate unit, and has the functions of setting standards, holding meetings, and setting dates thereof, preparing and conducting examinations, passing upon applicants, conducting investigations of violations of laws under its jurisdiction, issuing citations and holding hearings for the revocation of licenses, and the imposing of penalties following those hearings, insofar as these powers are given by statute to each respective board.

Enacted Stats 1937. Amended Stats 2008 ch 179 § 1 (SB 1498), effective January 1, 2009.



### § 108.5. Witness fees and expenses

In any investigation, proceeding or hearing which any board, commission or officer in the department is empowered to institute, conduct, or hold, any witness appearing at such investigation, proceeding or hearing whether upon a subpoena or voluntarily, may be paid the sum of twelve dollars (\$12) per day for every day in actual attendance at such investigation, proceeding or hearing and for his actual, necessary and reasonable expenses and such sums shall be a legal charge against the funds of the respective board, commission or officer; provided further, that no witness appearing other than at the instance of the board, commission or officer may be compensated out of such fund.

The board, commission or officer will determine the sums due any such witness and enter the amount on its minutes.

Added Stats 1943 ch 1035 § 1. Amended Stats 1957 ch 1908 § 6; Stats 1970 ch 1061 § 1.

### § 109. Review of decisions; Investigations

(a) The decisions of any of the boards comprising the department with respect to setting standards, conducting examinations, passing candidates, and revoking licenses, are not subject to review by the director, but are final within the limits provided by this code which are applicable to the particular board, except as provided in this section.

(b) The director may initiate an investigation of any allegations of misconduct in the preparation, administration, or scoring of an examination which is administered by a board, or in the review of qualifications which are a part of the licensing process of any board. A request for investigation shall be made by the director to the Division of Investigation through the chief of the division or to any law enforcement agency in the jurisdiction where the alleged misconduct occurred.

(c) The director may intervene in any matter of any board where an investigation by the Division of Investigation discloses probable cause to believe that the conduct or activity of a board, or its members or employees constitutes a violation of criminal law.

The term "intervene," as used in paragraph (c) of this section may include, but is not limited to, an application for a restraining order or injunctive relief as specified in Section 123.5, or a referral or request for criminal prosecution. For purposes of this section, the director shall be deemed to have standing under Section 123.5 and shall seek representation of the Attorney General, or other appropriate counsel in the event of a conflict in pursuing that action.

Enacted Stats 1937. Amended Stats 1991 ch 1013 § 1 (SB 961).

### § 110. Records and property

The department shall have possession and control of all records, books, papers, offices, equipment, supplies, funds, appropriations, land and other property—real or personal—now or hereafter held for the benefit or use of all of the bodies, offices or officers comprising the department. The title to all property held by any of these bodies, offices or officers for the use and benefit of the state, is vested in the State of California to be held in the possession of the department. Except as authorized by a board, the department shall not have the possession and

control of examination questions prior to submission to applicants at scheduled examinations.

Enacted Stats 1937. Amended Stats 1996 ch 829 § 1 (AB 3473).

### § 111. Commissioners on examination

Unless otherwise expressly provided, any board may, with the approval of the appointing power, appoint qualified persons, who shall be designated as commissioners on examination, to give the whole or any portion of any examination. A commissioner on examination need not be a member of the board but he shall have the same qualifications as one and shall be subject to the same rules.

Added Stats 1937 ch 474. Amended Stats 1947 ch 1350 § 3; Stats 1978 ch 1161 § 1.

### § 112. Publication and sale of directories of authorized persons

Notwithstanding any other provision of this code, no agency in the department, with the exception of the Board for Professional Engineers and Land Surveyors, shall be required to compile, publish, sell, or otherwise distribute a directory. When an agency deems it necessary to compile and publish a directory, the agency shall cooperate with the director in determining its form and content, the time and frequency of its publication, the persons to whom it is to be sold or otherwise distributed, and its price if it is sold. Any agency that requires the approval of the director for the compilation, publication, or distribution of a directory, under the law in effect at the time the amendment made to this section at the 1970 Regular Session of the Legislature becomes effective, shall continue to require that approval. As used in this section, "directory" means a directory, roster, register, or similar compilation of the names of persons who hold a license, certificate, permit, registration, or similar indicia of authority from the agency.

Added Stats 1937 ch 474. Amended Stats 1968 ch 1345 § 1; Stats 1970 ch 475 § 1; Stats 1998 ch 59 § 3 (AB 969).

### § 113. Conferences; Traveling expenses

Upon recommendation of the director, officers, and employees of the department, and the officers, members, and employees of the boards, committees, and commissions comprising it or subject to its jurisdiction may confer, in this state or elsewhere, with officers or employees of this state, its political subdivisions, other states, or the United States, or with other persons, associations, or organizations as may be of assistance to the department, board, committee, or commission in the conduct of its work. The officers, members, and employees shall be entitled to their actual traveling expenses incurred in pursuance hereof, but when these expenses are incurred with respect to travel outside of the state, they shall be subject to the approval of the Governor and the Director of Finance.

Added Stats 1937 ch 474. Amended Stats 1941 ch 885 § 1; Stats 2000 ch 277 § 1 (AB 2697); Stats 2001 ch 159 § 2 (SB 662).

### § 114. Reinstatement of expired license of licensee serving in military

(a) Notwithstanding any other provision of this code, any licensee or registrant of any board, commission, or bureau within the department whose license expired

while the licensee or registrant was on active duty as a member of the California National Guard or the United States Armed Forces, may, upon application, reinstate his or her license or registration without examination or penalty, provided that all of the following requirements are satisfied:

(1) His or her license or registration was valid at the time he or she entered the California National Guard or the United States Armed Forces.

(2) The application for reinstatement is made while serving in the California National Guard or the United States Armed Forces, or not later than one year from the date of discharge from active service or return to inactive military status.

(3) The application for reinstatement is accompanied by an affidavit showing the date of entrance into the service, whether still in the service, or date of discharge, and the renewal fee for the current renewal period in which the application is filed is paid.

(b) If application for reinstatement is filed more than one year after discharge or return to inactive status, the applicant, in the discretion of the licensing agency, may be required to pass an examination.

(c) If application for reinstatement is filed and the licensing agency determines that the applicant has not actively engaged in the practice of his or her profession while on active duty, then the licensing agency may require the applicant to pass an examination.

(d) Unless otherwise specifically provided in this code, any licensee or registrant who, either part time or full time, practices in this state the profession or vocation for which he or she is licensed or registered shall be required to maintain his or her license in good standing even though he or she is in military service.

For the purposes in this section, time spent by a licensee in receiving treatment or hospitalization in any veterans' facility during which he or she is prevented from practicing his or her profession or vocation shall be excluded from said period of one year.

Added Stats 1951 ch 185 § 2. Amended Stats 1953 ch 423 § 1; Stats 1961 ch 1253 § 1; Stats 2010 ch 389 § 1 (AB 2500), effective January 1, 2011; Stats 2011 ch 296 § 1 (AB 1023), effective January 1, 2012.

### § 114.3. Waiver of fees and requirements for active duty members of armed forces and national guard

(a) Notwithstanding any other provision of law, every board, as defined in Section 22, within the department shall waive the renewal fees, continuing education requirements, and other renewal requirements as determined by the board, if any are applicable, for any licensee or registrant called to active duty as a member of the United States Armed Forces or the California National Guard if all of the following requirements are met:

(1) The licensee or registrant possessed a current and valid license with the board at the time he or she was called to active duty.

(2) The renewal requirements are waived only for the period during which the licensee or registrant is on active duty service.

(3) Written documentation that substantiates the licensee or registrant's active duty service is provided to the board.

(b)(1) Except as specified in paragraph (2), the licensee or registrant shall not engage in any activities requiring a license during the period that the waivers provided by this section are in effect.

(2) If the licensee or registrant will provide services for which he or she is licensed while on active duty, the board shall convert the license status to military active and no private practice of any type shall be permitted.

(c) In order to engage in any activities for which he or she is licensed once discharged from active duty, the licensee or registrant shall meet all necessary renewal requirements as determined by the board within six months from the licensee's or registrant's date of discharge from active duty service.

(d) After a licensee or registrant receives notice of his or her discharge date, the licensee or registrant shall notify the board of his or her discharge from active duty within 60 days of receiving his or her notice of discharge.

(e) A board may adopt regulations to carry out the provisions of this section.

(f) This section shall not apply to any board that has a similar license renewal waiver process statutorily authorized for that board.

Added Stats 2012 ch 742 § 1 (AB 1588), effective January 1, 2013.

### § 115. Applicability of Section 114

The provisions of Section 114 of this code are also applicable to a licensee or registrant whose license or registration was obtained while in the armed services.

Added Stats 1951 ch 1577 § 1.

### § 115.5. Board required to expedite licensure process for certain applicants; Adoption of regulations

(a) A board within the department shall expedite the licensure process for an applicant who meets both of the following requirements:

(1) Supplies evidence satisfactory to the board that the applicant is married to, or in a domestic partnership or other legal union with, an active duty member of the Armed Forces of the United States who is assigned to a duty station in this state under official active duty military orders.

(2) Holds a current license in another state, district, or territory of the United States in the profession or vocation for which he or she seeks a license from the board.

(b) A board may adopt regulations necessary to administer this section.

Added Stats 2012 ch 399 § 1 (AB 1904), effective January 1, 2013.

### § 116. Audit and review of disciplinary proceedings; Report to Legislature

(a) The director may audit and review, upon his or her own initiative, or upon the request of a consumer or licensee, inquiries and complaints regarding licensees, dismissals of disciplinary cases, the opening, conduct, or closure of investigations, informal conferences, and discipline short of formal accusation by the Medical Board of California, the allied health professional boards, and the California Board of Podiatric Medicine. The director may make recommendations for changes to the disciplin-

ary system to the appropriate board, the Legislature, or both.

(b) The director shall report to the Chairpersons of the Senate Business and Professions Committee and the Assembly Health Committee annually, commencing March 1, 1995, regarding his or her findings from any audit, review, or monitoring and evaluation conducted pursuant to this section.

Added Stats 1993 ch 1267 § 1 (SB 916).

**§ 117. [Section repealed 1997.]**

Added Stats 1996 ch 191 § 1 (SB 1763), effective July 22, 1996. Repealed, operative July 1, 1997, by its own terms. The repealed section related to powers and duties of the Department of Consumer Affairs.

**§ 118. Effect of withdrawal of application; Effect of suspension, forfeiture, etc., of license**

(a) The withdrawal of an application for a license after it has been filed with a board in the department shall not, unless the board has consented in writing to such withdrawal, deprive the board of its authority to institute or continue a proceeding against the applicant for the denial of the license upon any ground provided by law or to enter an order denying the license upon any such ground.

(b) The suspension, expiration, or forfeiture by operation of law of a license issued by a board in the department, or its suspension, forfeiture, or cancellation by order of the board or by order of a court of law, or its surrender without the written consent of the board, shall not, during any period in which it may be renewed, restored, reissued, or reinstated, deprive the board of its authority to institute or continue a disciplinary proceeding against the licensee upon any ground provided by law or to enter an order suspending or revoking the license or otherwise taking disciplinary action against the licensee on any such ground.

(c) As used in this section, "board" includes an individual who is authorized by any provision of this code to issue, suspend, or revoke a license, and "license" includes "certificate," "registration," and "permit."

Added Stats 1961 ch 1079 § 1.

**§ 119. Misdemeanors pertaining to use of licenses**

Any person who does any of the following is guilty of a misdemeanor:

(a) Displays or causes or permits to be displayed or has in his or her possession either of the following:

(1) A canceled, revoked, suspended, or fraudulently altered license.

(2) A fictitious license or any document simulating a license or purporting to be or have been issued as a license.

(b) Lends his or her license to any other person or knowingly permits the use thereof by another.

(c) Displays or represents any license not issued to him or her as being his or her license.

(d) Fails or refuses to surrender to the issuing authority upon its lawful written demand any license, registration, permit, or certificate which has been suspended, revoked, or canceled.

(e) Knowingly permits any unlawful use of a license issued to him or her.

(f) Photographs, photostats, duplicates, manufactures, or in any way reproduces any license or facsimile thereof in a manner that it could be mistaken for a valid license, or displays or has in his or her possession any such photograph, photostat, duplicate, reproduction, or facsimile unless authorized by this code.

(g) Buys or receives a fraudulent, forged, or counterfeited license knowing that it is fraudulent, forged, or counterfeited. For purposes of this subdivision, "fraudulent" means containing any misrepresentation of fact.

As used in this section, "license" includes "certificate," "permit," "authority," and "registration" or any other indicia giving authorization to engage in a business or profession regulated by this code or referred to in Section 1000 or 3600.

Added Stats 1965 ch 1083 § 1. Amended Stats 1990 ch 350 § 1 (SB 2084) (ch 1207 prevails), ch 1207 § 1 (AB 3242); Stats 1994 ch 1206 § 1 (SB 1775); Stats 2000 ch 568 § 1 (AB 2888).

**§ 120. Possession by surviving spouse of canceled certificates**

(a) Subdivision (a) of Section 119 shall not apply to a surviving spouse having in his or her possession or displaying a deceased spouse's canceled certified public accountant certificate or canceled public accountant certificate that has been canceled by official action of the California Board of Accountancy.

(b) Notwithstanding Section 119, any person who has received a certificate of certified public accountant or a certificate of public accountant from the board may possess and may display the certificate received unless the person's certificate, permit, or registration has been suspended or revoked.

Added Stats 1967 ch 497 § 1. Amended Stats 1998 ch 878 § 1 (SB 2239); Stats 2000 ch 1055 § 1 (AB 2889), effective September 30, 2000.

**§ 121. Practice during period between renewal and receipt of evidence of renewal**

No licensee who has complied with the provisions of this code relating to the renewal of his or her license prior to expiration of such license shall be deemed to be engaged illegally in the practice of his or her business or profession during any period between such renewal and receipt of evidence of such renewal which may occur due to delay not the fault of the applicant.

As used in this section, "license" includes "certificate," "permit," "authorization," and "registration," or any other indicia giving authorization, by any agency, board, bureau, commission, committee, or entity within the Department of Consumer Affairs, to engage in a business or profession regulated by this code or by the board referred to in the Chiropractic Act or the Osteopathic Act.

Added Stats 1979 ch 77 § 1.

**§ 121.5. Application of fees to licenses or registrations lawfully inactivated**

Except as otherwise provided in this code, the application of delinquency fees or accrued and unpaid renewal fees for the renewal of expired licenses or registrations shall not apply to licenses or registrations that have lawfully been designated as inactive or retired.

Added Stats 2001 ch 435 § 1 (SB 349).

**§ 122. Fee for issuance of duplicate certificate**

Except as otherwise provided by law, the department and each of the boards, bureaus, committees, and commissions within the department may charge a fee for the processing and issuance of a duplicate copy of any certificate of licensure or other form evidencing licensure or renewal of licensure. The fee shall be in an amount sufficient to cover all costs incident to the issuance of the duplicate certificate or other form but shall not exceed twenty-five dollars (\$25).

Added Stats 1986 ch 951 § 1.

**§ 123. Conduct constituting subversion of licensing examination; Penalties and damages**

It is a misdemeanor for any person to engage in any conduct which subverts or attempts to subvert any licensing examination or the administration of an examination, including, but not limited to:

(a) Conduct which violates the security of the examination materials; removing from the examination room any examination materials without authorization; the unauthorized reproduction by any means of any portion of the actual licensing examination; aiding by any means the unauthorized reproduction of any portion of the actual licensing examination; paying or using professional or paid examination-takers for the purpose of reconstructing any portion of the licensing examination; obtaining examination questions or other examination material, except by specific authorization either before, during, or after an examination; or using or purporting to use any examination questions or materials which were improperly removed or taken from any examination for the purpose of instructing or preparing any applicant for examination; or selling, distributing, buying, receiving, or having unauthorized possession of any portion of a future, current, or previously administered licensing examination.

(b) Communicating with any other examinee during the administration of a licensing examination; copying answers from another examinee or permitting one's answers to be copied by another examinee; having in one's possession during the administration of the licensing examination any books, equipment, notes, written or printed materials, or data of any kind, other than the examination materials distributed, or otherwise authorized to be in one's possession during the examination; or impersonating any examinee or having an impersonator take the licensing examination on one's behalf.

Nothing in this section shall preclude prosecution under the authority provided for in any other provision of law.

In addition to any other penalties, a person found guilty of violating this section, shall be liable for the actual damages sustained by the agency administering the examination not to exceed ten thousand dollars (\$10,000) and the costs of litigation.

(c) If any provision of this section or the application thereof to any person or circumstances is held invalid, that invalidity shall not affect other provisions or applications of the section that can be given effect without the invalid provision or application, and to this end the provisions of this section are severable.

Added Stats 1989 ch 1022 § 1. Amended Stats 1991 ch 647 § 1 (SB 879).

**§ 123.5. Enjoining violations**

Whenever any person has engaged, or is about to engage, in any acts or practices which constitute, or will constitute, a violation of Section 123, the superior court in and for the county wherein the acts or practices take place, or are about to take place, may issue an injunction, or other appropriate order, restraining such conduct on application of a board, the Attorney General or the district attorney of the county.

The proceedings under this section shall be governed by Chapter 3 (commencing with Section 525) of Title 7 of Part 2 of the Code of Civil Procedure.

The remedy provided for by this section shall be in addition to, and not a limitation on, the authority provided for in any other provision of law.

Added Stats 1983 ch 95 § 2, as B & P C § 497. Amended and Renumbered by Stats 1989 ch 1022 § 4.

**§ 124. Manner of notice**

Notwithstanding subdivision (c) of Section 11505 of the Government Code, whenever written notice, including a notice, order, or document served pursuant to Chapter 3.5 (commencing with Section 11340), Chapter 4 (commencing with Section 11370), or Chapter 5 (commencing with Section 11500), of Part 1 of Division 3 of Title 2 of the Government Code, is required to be given by any board in the department, the notice may be given by regular mail addressed to the last known address of the licentiate or by personal service, at the option of the board.

Added Stats 1961 ch 1253 § 2. Amended Stats 1994 ch 26 § 4 (AB 1807), effective March 30, 1994; Stats 1995 ch 938 § 1 (SB 523), operative July 1, 1997.

**§ 125. Misdemeanor offenses by licensees**

Any person, licensed under Division 1 (commencing with Section 100), Division 2 (commencing with Section 500), or Division 3 (commencing with Section 5000) is guilty of a misdemeanor and subject to the disciplinary provisions of this code applicable to him or her, who conspires with a person not so licensed to violate any provision of this code, or who, with intent to aid or assist that person in violating those provisions does either of the following:

- (a) Allows his or her license to be used by that person.
- (b) Acts as his or her agent or partner.

Added Stats 1949 ch 308 § 1. Amended Stats 1994 ch 1206 § 2 (SB 1775).

**§ 125.3. Direction to licentiate violating licensing act to pay costs of investigation and enforcement**

(a) Except as otherwise provided by law, in any order issued in resolution of a disciplinary proceeding before any board within the department or before the Osteopathic Medical Board, upon request of the entity bringing the proceeding, the administrative law judge may direct a licentiate found to have committed a violation or violations of the licensing act to pay a sum not to exceed the reasonable costs of the investigation and enforcement of the case.

(b) In the case of a disciplined licentiate that is a corporation or a partnership, the order may be made against the licensed corporate entity or licensed partnership.

(c) A certified copy of the actual costs, or a good faith estimate of costs where actual costs are not available, signed by the entity bringing the proceeding or its designated representative shall be prima facie evidence of reasonable costs of investigation and prosecution of the case. The costs shall include the amount of investigative and enforcement costs up to the date of the hearing, including, but not limited to, charges imposed by the Attorney General.

(d) The administrative law judge shall make a proposed finding of the amount of reasonable costs of investigation and prosecution of the case when requested pursuant to subdivision (a). The finding of the administrative law judge with regard to costs shall not be reviewable by the board to increase the cost award. The board may reduce or eliminate the cost award, or remand to the administrative law judge if the proposed decision fails to make a finding on costs requested pursuant to subdivision (a).

(e) If an order for recovery of costs is made and timely payment is not made as directed in the board's decision, the board may enforce the order for repayment in any appropriate court. This right of enforcement shall be in addition to any other rights the board may have as to any licentiate to pay costs.

(f) In any action for recovery of costs, proof of the board's decision shall be conclusive proof of the validity of the order of payment and the terms for payment.

(g)(1) Except as provided in paragraph (2), the board shall not renew or reinstate the license of any licentiate who has failed to pay all of the costs ordered under this section.

(2) Notwithstanding paragraph (1), the board may, in its discretion, conditionally renew or reinstate for a maximum of one year the license of any licentiate who demonstrates financial hardship and who enters into a formal agreement with the board to reimburse the board within that one-year period for the unpaid costs.

(h) All costs recovered under this section shall be considered a reimbursement for costs incurred and shall be deposited in the fund of the board recovering the costs to be available upon appropriation by the Legislature.

(i) Nothing in this section shall preclude a board from including the recovery of the costs of investigation and enforcement of a case in any stipulated settlement.

(j) This section does not apply to any board if a specific statutory provision in that board's licensing act provides for recovery of costs in an administrative disciplinary proceeding.

(k) Notwithstanding the provisions of this section, the Medical Board of California shall not request nor obtain from a physician and surgeon, investigation and prosecution costs for a disciplinary proceeding against the licentiate. The board shall ensure that this subdivision is revenue neutral with regard to it and that any loss of revenue or increase in costs resulting from this subdivision is offset by an increase in the amount of the initial license fee and the biennial renewal fee, as provided in subdivision (e) of Section 2435.

Added Stats 1992 ch 1059 § 1 (AB 3745), ch 1289 § 1 (AB 2743). Amended Stats 2001 ch 728 § 1 (SB 724); Stats 2005 ch 674 § 2 (SB 231), effective January 1, 2006; Stats 2006 ch 223 § 2 (SB 1438), effective January 1, 2007.

### § 125.5. Enjoining violations; Restitution orders

(a) The superior court for the county in which any person has engaged or is about to engage in any act which constitutes a violation of a chapter of this code administered or enforced by a board within the department may, upon a petition filed by the board with the approval of the director, issue an injunction or other appropriate order restraining such conduct. The proceedings under this section shall be governed by Chapter 3 (commencing with Section 525) of Title 7 of Part 2 of the Code of Civil Procedure. As used in this section, "board" includes commission, bureau, division, agency and a medical quality review committee.

(b) The superior court for the county in which any person has engaged in any act which constitutes a violation of a chapter of this code administered or enforced by a board within the department may, upon a petition filed by the board with the approval of the director, order such person to make restitution to persons injured as a result of such violation.

(c) The court may order a person subject to an injunction or restraining order, provided for in subdivision (a) of this section, or subject to an order requiring restitution pursuant to subdivision (b), to reimburse the petitioning board for expenses incurred by the board in its investigation related to its petition.

(d) The remedy provided for by this section shall be in addition to, and not a limitation on, the authority provided for in any other section of this code.

Added Stats 1972 ch 1238 § 1. Amended Stats 1973 ch 632 § 1; Stats 2d Ex Sess 1975 ch 1 § 2; Stats 1982 ch 517 § 1.

### § 125.6. Unlawful discrimination by licensees

(a)(1) With regard to an applicant, every person who holds a license under the provisions of this code is subject to disciplinary action under the disciplinary provisions of this code applicable to that person if, because of any characteristic listed or defined in subdivision (b) or (e) of Section 51 of the Civil Code, he or she refuses to perform the licensed activity or aids or incites the refusal to perform that licensed activity by another licensee, or if, because of any characteristic listed or defined in subdivision (b) or (e) of Section 51 of the Civil Code, he or she makes any discrimination, or restriction in the performance of the licensed activity.

(2) Nothing in this section shall be interpreted to prevent a physician or health care professional licensed pursuant to Division 2 (commencing with Section 500) from considering any of the characteristics of a patient listed in subdivision (b) or (e) of Section 51 of the Civil Code if that consideration is medically necessary and for the sole purpose of determining the appropriate diagnosis or treatment of the patient.

(3) Nothing in this section shall be interpreted to apply to discrimination by employers with regard to employees or prospective employees, nor shall this section authorize action against any club license issued pursuant to Article 4 (commencing with Section 23425) of Chapter 3 of Division 9 because of discriminatory membership policy.

(4) The presence of architectural barriers to an individual with physical disabilities that conform to applicable state or local building codes and regulations shall not constitute discrimination under this section.

(b)(1) Nothing in this section requires a person licensed pursuant to Division 2 (commencing with Section 500) to permit an individual to participate in, or benefit from, the licensed activity of the licensee where that individual poses a direct threat to the health or safety of others. For this purpose, the term “direct threat” means a significant risk to the health or safety of others that cannot be eliminated by a modification of policies, practices, or procedures or by the provision of auxiliary aids and services.

(2) Nothing in this section requires a person licensed pursuant to Division 2 (commencing with Section 500) to perform a licensed activity for which he or she is not qualified to perform.

(c)(1) “Applicant,” as used in this section, means a person applying for licensed services provided by a person licensed under this code.

(2) “License,” as used in this section, includes “certificate,” “permit,” “authority,” and “registration” or any other indicia giving authorization to engage in a business or profession regulated by this code.

Added Stats 1974 ch 1350 § 1. Amended Stats 1977 ch 293 § 1; Stats 1980 ch 191 § 1; Stats 1992 ch 913 § 2 (AB 1077); Stats 2007 ch 568 § 2 (AB 14), effective January 1, 2008.

### § 125.7. Restraining orders

In addition to the remedy provided for in Section 125.5, the superior court for the county in which any licensee licensed under Division 2 (commencing with Section 500), or any initiative act referred to in that division, has engaged or is about to engage in any act that constitutes a violation of a chapter of this code administered or enforced by a board referred to in Division 2 (commencing with Section 500), may, upon a petition filed by the board and accompanied by an affidavit or affidavits in support thereof and a memorandum of points and authorities, issue a temporary restraining order or other appropriate order restraining the licensee from engaging in the business or profession for which the person is licensed or from any part thereof, in accordance with this section.

(a) If the affidavits in support of the petition show that the licensee has engaged or is about to engage in acts or omissions constituting a violation of a chapter of this code and if the court is satisfied that permitting the licensee to continue to engage in the business or profession for which the license was issued will endanger the public health, safety, or welfare, the court may issue an order temporarily restraining the licensee from engaging in the profession for which he or she is licensed.

(b) The order may not be issued without notice to the licensee unless it appears from facts shown by the affidavits that serious injury would result to the public before the matter can be heard on notice.

(c) Except as otherwise specifically provided by this section, proceedings under this section shall be governed by Chapter 3 (commencing with Section 525) of Title 7 of Part 2 of the Code of Civil Procedure.

(d) When a restraining order is issued pursuant to this section, or within a time to be allowed by the superior court, but in any case not more than 30 days after the restraining order is issued, an accusation shall be filed with the board pursuant to Section 11503 of the Government Code or, in the case of a licensee of the State

Department of Health Services, with that department pursuant to Section 100171 of the Health and Safety Code. The accusation shall be served upon the licensee as provided by Section 11505 of the Government Code. The licensee shall have all of the rights and privileges available as specified in Chapter 5 (commencing with Section 11500) of Part 1 of Division 3 of Title 2 of the Government Code. However, if the licensee requests a hearing on the accusation, the board shall provide the licensee with a hearing within 30 days of the request and a decision within 15 days of the date the decision is received from the administrative law judge, or the court may nullify the restraining order previously issued. Any restraining order issued pursuant to this section shall be dissolved by operation of law at the time the board’s decision is subject to judicial review pursuant to Section 1094.5 of the Code of Civil Procedure.

(e) The remedy provided for in this section shall be in addition to, and not a limitation upon, the authority provided by any other provision of this code.

Added Stats 1977 ch 292 § 1. Amended Stats 1982 ch 517 § 2; Stats 1994 ch 1206 § 3 (SB 1775); Stats 1997 ch 220 § 1 (SB 68), effective August 4, 1997; Stats 1998 ch 878 § 1.5 (SB 2239).

### § 125.8. Temporary order restraining licensee engaged or about to engage in violation of law

In addition to the remedy provided for in Section 125.5, the superior court for the county in which any licensee licensed under Division 3 (commencing with Section 5000) or Chapter 2 (commencing with Section 18600) or Chapter 3 (commencing with Section 19000) of Division 8 has engaged or is about to engage in any act which constitutes a violation of a chapter of this code administered or enforced by a board referred to in Division 3 (commencing with Section 5000) or Chapter 2 (commencing with Section 18600) or Chapter 3 (commencing with Section 19000) of Division 8 may, upon a petition filed by the board and accompanied by an affidavit or affidavits in support thereof and a memorandum of points and authorities, issue a temporary restraining order or other appropriate order restraining the licensee from engaging in the business or profession for which the person is licensed or from any part thereof, in accordance with the provisions of this section.

(a) If the affidavits in support of the petition show that the licensee has engaged or is about to engage in acts or omissions constituting a violation of a chapter of this code and if the court is satisfied that permitting the licensee to continue to engage in the business or profession for which the license was issued will endanger the public health, safety, or welfare, the court may issue an order temporarily restraining the licensee from engaging in the profession for which he is licensed.

(b) Such order may not be issued without notice to the licensee unless it appears from facts shown by the affidavits that serious injury would result to the public before the matter can be heard on notice.

(c) Except as otherwise specifically provided by this section, proceedings under this section shall be governed by Chapter 3 (commencing with Section 525) of Title 7 of Part 2 of the Code of Civil Procedure.

(d) When a restraining order is issued pursuant to this section, or within a time to be allowed by the superior court, but in any case not more than 30 days

after the restraining order is issued, an accusation shall be filed with the board pursuant to Section 11503 of the Government Code. The accusation shall be served upon the licensee as provided by Section 11505 of the Government Code. The licensee shall have all of the rights and privileges available as specified in Chapter 5 (commencing with Section 11500) of Part 1 of Division 3 of Title 2 of the Government Code; however, if the licensee requests a hearing on the accusation, the board must provide the licensee with a hearing within 30 days of the request and a decision within 15 days of the date of the conclusion of the hearing, or the court may nullify the restraining order previously issued. Any restraining order issued pursuant to this section shall be dissolved by operation of law at such time the board's decision is subject to judicial review pursuant to Section 1094.5 of the Code of Civil Procedure.

Added Stats 1977 ch 443 § 1. Amended Stats 1982 ch 517 § 3.

#### **§ 125.9. System for issuance of citations to licensees; Contents; Fines**

(a) Except with respect to persons regulated under Chapter 11 (commencing with Section 7500), any board, bureau, or commission within the department, the board created by the Chiropractic Initiative Act, and the Osteopathic Medical Board of California, may establish, by regulation, a system for the issuance to a licensee of a citation which may contain an order of abatement or an order to pay an administrative fine assessed by the board, bureau, or commission where the licensee is in violation of the applicable licensing act or any regulation adopted pursuant thereto.

(b) The system shall contain the following provisions:

(1) Citations shall be in writing and shall describe with particularity the nature of the violation, including specific reference to the provision of law determined to have been violated.

(2) Whenever appropriate, the citation shall contain an order of abatement fixing a reasonable time for abatement of the violation.

(3) In no event shall the administrative fine assessed by the board, bureau, or commission exceed five thousand dollars (\$5,000) for each inspection or each investigation made with respect to the violation, or five thousand dollars (\$5,000) for each violation or count if the violation involves fraudulent billing submitted to an insurance company, the Medi-Cal program, or Medicare. In assessing a fine, the board, bureau, or commission shall give due consideration to the appropriateness of the amount of the fine with respect to factors such as the gravity of the violation, the good faith of the licensee, and the history of previous violations.

(4) A citation or fine assessment issued pursuant to a citation shall inform the licensee that if he or she desires a hearing to contest the finding of a violation, that hearing shall be requested by written notice to the board, bureau, or commission within 30 days of the date of issuance of the citation or assessment. If a hearing is not requested pursuant to this section, payment of any fine shall not constitute an admission of the violation charged. Hearings shall be held pursuant to Chapter 5 (commencing with Section 11500) of Part 1 of Division 3 of Title 2 of the Government Code.

(5) Failure of a licensee to pay a fine within 30 days of the date of assessment, unless the citation is being appealed, may result in disciplinary action being taken by the board, bureau, or commission. Where a citation is not contested and a fine is not paid, the full amount of the assessed fine shall be added to the fee for renewal of the license. A license shall not be renewed without payment of the renewal fee and fine.

(c) The system may contain the following provisions:

(1) A citation may be issued without the assessment of an administrative fine.

(2) Assessment of administrative fines may be limited to only particular violations of the applicable licensing act.

(d) Notwithstanding any other provision of law, if a fine is paid to satisfy an assessment based on the finding of a violation, payment of the fine shall be represented as satisfactory resolution of the matter for purposes of public disclosure.

(e) Administrative fines collected pursuant to this section shall be deposited in the special fund of the particular board, bureau, or commission.

Added Stats 1986 ch 1379 § 2. Amended Stats 1987 ch 1088 § 1; Stats 1991 ch 521 § 1 (SB 650); Stats 1995 ch 381 § 4 (AB 910), effective August 4, 1995, ch 708 § 1 (SB 609); Stats 2000 ch 197 § 1 (SB 1636); Stats 2001 ch 309 § 1 (AB 761), ch 728 § 1.2 (SB 724); Stats 2003 ch 788 § 1 (SB 362); Stats 2012 ch 291 § 1 (SB 1077), effective January 1, 2013.

#### **§ 126. Submission of reports to Governor**

Notwithstanding any other provision of this code, any board, commission, examining committee, or other similarly constituted agency within the department required prior to the effective date of this section to submit reports to the Governor under any provision of this code shall not be required to submit such reports.

Added Stats 1967 ch 660 § 1.

#### **§ 127. Submission of reports to director**

Notwithstanding any other provision of this code, the director may require such reports from any board, commission, examining committee, or other similarly constituted agency within the department as he deems reasonably necessary on any phase of their operations.

Added Stats 1967 ch 660 § 2.

#### **§ 128. Sale of equipment, supplies, or services for use in violation of licensing requirements**

Notwithstanding any other provision of law, it is a misdemeanor to sell equipment, supplies, or services to any person with knowledge that the equipment, supplies, or services are to be used in the performance of a service or contract in violation of the licensing requirements of this code.

The provisions of this section shall not be applicable to cash sales of less than one hundred dollars (\$100).

For the purposes of this section, "person" includes, but is not limited to, a company, partnership, limited liability company, firm, or corporation.

For the purposes of this section, "license" includes certificate or registration.

A violation of this section shall be punishable by a fine of not less than one thousand dollars (\$1,000) and by imprisonment in the county jail not exceeding six months.

Added Stats 1971 ch 1052 § 1. Amended Stats 1994 ch 1010 § 1 (SB 2053).

**§ 128.5. Reduction of license fees in event of surplus funds**

(a) Notwithstanding any other provision of law, if at the end of any fiscal year, an agency within the Department of Consumer Affairs, except the agencies referred to in subdivision (b), has unencumbered funds in an amount that equals or is more than the agency's operating budget for the next two fiscal years, the agency shall reduce license or other fees, whether the license or other fees be fixed by statute or may be determined by the agency within limits fixed by statute, during the following fiscal year in an amount that will reduce any surplus funds of the agency to an amount less than the agency's operating budget for the next two fiscal years.

(b) Notwithstanding any other provision of law, if at the end of any fiscal year, the California Architects Board, the Board of Behavioral Sciences, the Veterinary Medical Board, the Court Reporters Board of California, the Medical Board of California, the Board of Vocational Nursing and Psychiatric Technicians, or the Bureau of Security and Investigative Services has unencumbered funds in an amount that equals or is more than the agency's operating budget for the next two fiscal years, the agency shall reduce license or other fees, whether the license or other fees be fixed by statute or may be determined by the agency within limits fixed by statute, during the following fiscal year in an amount that will reduce any surplus funds of the agency to an amount less than the agency's operating budget for the next two fiscal years.

Added Stats 1972 ch 938 § 2, effective August 16, 1972, as B & P C § 128. Amended Stats 1973 ch 863 § 3. Amended and Renumbered by Stats 1978 ch 1161 § 4. Amended Stats 1987 ch 850 § 3; Stats 1989 ch 886 § 2; Stats 1993 ch 1263 § 2 (AB 936); Stats 1994 ch 26 § 5 (AB 1807), effective March 30, 1994; Stats 1995 ch 60 § 2 (SB 42), effective July 6, 1995; Stats 1997 ch 759 § 2 (SB 827); Stats 2000 ch 1054 § 1 (SB 1863); Stats 2009 ch 308 § 3 (SB 819), effective January 1, 2010.

**§ 129. Handling of complaints; Reports to Legislature**

(a) As used in this section, "board" means every board, bureau, commission, committee and similarly constituted agency in the department which issues licenses.

(b) Each board shall, upon receipt of any complaint respecting a licentiate thereof, notify the complainant of the initial administrative action taken on his complaint within 10 days of receipt. Each board shall thereafter notify the complainant of the final action taken on his complaint. There shall be a notification made in every case in which the complainant is known. If the complaint is not within the jurisdiction of the board or if the board is unable to dispose satisfactorily of the complaint, the board shall transmit the complaint together with any evidence or information it has concerning the complaint to the agency, public or private, whose authority in the opinion of the board will provide the most effective means to secure the relief sought. The board shall notify the complainant of such action and of any other means which may be available to the complainant to secure relief.

(c) The board shall, when the board deems it appropriate, notify the person against whom the complaint is made of the nature of the complaint, may request appropriate relief for the complainant, and may meet and confer with the complainant and the licentiate in order

to mediate the complaint. Nothing in this subdivision shall be construed as authorizing or requiring any board to set or to modify any fee charged by a licentiate.

(d) It shall be the continuing duty of the board to ascertain patterns of complaints and to report on all actions taken with respect to such patterns of complaints to the director and to the Legislature at least once a year. The board shall evaluate those complaints dismissed for lack of jurisdiction or no violation and recommend to the director and to the Legislature at least once a year such statutory changes as it deems necessary to implement the board's functions and responsibilities under this section.

(e) It shall be the continuing duty of the board to take whatever action it deems necessary, with the approval of the director, to inform the public of its functions under this section.

Added Stats 1972 ch 1041 § 1.

**§ 132. Requirements for institution or joinder of legal action by state agency against other state or federal agency**

No board, commission, examining committee, or any other agency within the department may institute or join any legal action against any other agency within the state or federal government without the permission of the director.

Prior to instituting or joining in a legal action against an agency of the state or federal government, a board, commission, examining committee, or any other agency within the department shall present a written request to the director to do so.

Within 30 days of receipt of the request, the director shall communicate his or her approval or denial of the request and his or her reasons for approval or denial to the requesting agency in writing. If the director does not act within 30 days, the request shall be deemed approved.

A requesting agency within the department may override the director's denial of its request to institute or join a legal action against a state or federal agency by a two-thirds vote of the members of the board, commission, examining committee, or other agency, which vote shall include the vote of at least one public member of that board, commission, examining committee, or other agency.

Added Stats 1990 ch 285 § 1 (AB 2984).

**§ 133. [No section of this number.]**

**§ 134. Proration of license fees**

When the term of any license issued by any agency in the department exceeds one year, initial license fees for licenses which are issued during a current license term shall be prorated on a yearly basis.

Added Stats 1974 ch 743 § 1. Amended Stats 1978 ch 1161 § 6.

**§ 135. Reexamination of applicants**

No agency in the department shall, on the basis of an applicant's failure to successfully complete prior examinations, impose any additional limitations, restrictions, prerequisites, or requirements on any applicant who wishes to participate in subsequent examinations except



that any examining agency which allows an applicant conditional credit for successfully completing a divisible part of an examination may require that an applicant be reexamined in those parts successfully completed if such applicant has not successfully completed all parts of the examination within a required period of time established by the examining agency. Nothing in this section, however, requires the exemption of such applicant from the regular fees and requirements normally associated with examinations.

Added Stats 1974 ch 743 § 2.

**§ 136. Notification of change of address; Punishment for failure to comply**

(a) Each person holding a license, certificate, registration, permit, or other authority to engage in a profession or occupation issued by a board within the department shall notify the issuing board at its principal office of any change in his or her mailing address within 30 days after the change, unless the board has specified by regulations a shorter time period.

(b) Except as otherwise provided by law, failure of a licensee to comply with the requirement in subdivision (a) constitutes grounds for the issuance of a citation and administrative fine, if the board has the authority to issue citations and administrative fines.

Added Stats 1994 ch 26 § 7 (AB 1807), effective March 30, 1994.

**§ 137. Regulations requiring inclusion of license numbers in advertising, etc.**

Any agency within the department may promulgate regulations requiring licensees to include their license numbers in any advertising, soliciting, or other presentments to the public.

However, nothing in this section shall be construed to authorize regulation of any person not a licensee who engages in advertising, solicitation, or who makes any other presentment to the public on behalf of a licensee. Such a person shall incur no liability pursuant to this section for communicating in any advertising, soliciting, or other presentment to the public a licensee's license number exactly as provided to him by the licensee or for failure to communicate such number if none is provided to him by the licensee.

Added Stats 1974 ch 743 § 3.

**§ 138. Notice that practitioner is licensed; Evaluation of licensing examination**

Every board in the department, as defined in Section 22, shall initiate the process of adopting regulations on or before June 30, 1999, to require its licensees, as defined in Section 23.8, to provide notice to their clients or customers that the practitioner is licensed by this state. A board shall be exempt from the requirement to adopt regulations pursuant to this section if the board has in place, in statute or regulation, a requirement that provides for consumer notice of a practitioner's status as a licensee of this state.

Added Stats 1998 ch 879 § 1 (SB 2238). Amended Stats 1999 ch 67 § 1 (AB 1105), effective July 6, 1999.

**§ 139. Policy for examination development and validation, and occupational analysis**

(a) The Legislature finds and declares that occupational analyses and examination validation studies are

fundamental components of licensure programs. It is the intent of the Legislature that the policy developed by the department pursuant to subdivision (b) be used by the fiscal, policy, and sunset review committees of the Legislature in their annual reviews of these boards, programs, and bureaus.

(b) Notwithstanding any other provision of law, the department shall develop, in consultation with the boards, programs, bureaus, and divisions under its jurisdiction, and the Osteopathic Medical Board of California and the State Board of Chiropractic Examiners, a policy regarding examination development and validation, and occupational analysis. The department shall finalize and distribute this policy by September 30, 1999, to each of the boards, programs, bureaus, and divisions under its jurisdiction and to the Osteopathic Medical Board of California and the State Board of Chiropractic Examiners. This policy shall be submitted in draft form at least 30 days prior to that date to the appropriate fiscal, policy, and sunset review committees of the Legislature for review. This policy shall address, but shall not be limited to, the following issues:

(1) An appropriate schedule for examination validation and occupational analyses, and circumstances under which more frequent reviews are appropriate.

(2) Minimum requirements for psychometrically sound examination validation, examination development, and occupational analyses, including standards for sufficient number of test items.

(3) Standards for review of state and national examinations.

(4) Setting of passing standards.

(5) Appropriate funding sources for examination validations and occupational analyses.

(6) Conditions under which boards, programs, and bureaus should use internal and external entities to conduct these reviews.

(7) Standards for determining appropriate costs of reviews of different types of examinations, measured in terms of hours required.

(8) Conditions under which it is appropriate to fund permanent and limited term positions within a board, program, or bureau to manage these reviews.

(c) Every regulatory board and bureau, as defined in Section 22, and every program and bureau administered by the department, the Osteopathic Medical Board of California, and the State Board of Chiropractic Examiners, shall submit to the director on or before December 1, 1999, and on or before December 1 of each subsequent year, its method for ensuring that every licensing examination administered by or pursuant to contract with the board is subject to periodic evaluation. The evaluation shall include (1) a description of the occupational analysis serving as the basis for the examination; (2) sufficient item analysis data to permit a psychometric evaluation of the items; (3) an assessment of the appropriateness of prerequisites for admittance to the examination; and (4) an estimate of the costs and personnel required to perform these functions. The evaluation shall be revised and a new evaluation submitted to the director whenever, in the judgment of the board, program, or bureau, there is a substantial change in the examination or the prerequisites for admittance to the examination.

(d) The evaluation may be conducted by the board, program, or bureau, the Office of Professional Examination Services of the department, the Osteopathic Medical Board of California, or the State Board of Chiropractic Examiners or pursuant to a contract with a qualified private testing firm. A board, program, or bureau that provides for development or administration of a licensing examination pursuant to contract with a public or private entity may rely on an occupational analysis or item analysis conducted by that entity. The department shall compile this information, along with a schedule specifying when examination validations and occupational analyses shall be performed, and submit it to the appropriate fiscal, policy, and sunset review committees of the Legislature by September 30 of each year. It is the intent of the Legislature that the method specified in this report be consistent with the policy developed by the department pursuant to subdivision (b).

Added Stats 1999 ch 67 § 2 (AB 1105), effective July 6, 1999. Amended Stats 2009 ch 307 § 1 (SB 821), effective January 1, 2010.

**§ 140. Disciplinary action; Licensee's failure to record cash transactions in payment of employee wages**

Any board, as defined in Section 22, which is authorized under this code to take disciplinary action against a person who holds a license may take disciplinary action upon the ground that the licensee has failed to record and preserve for not less than three years, any and all cash transactions involved in the payment of employee wages by a licensee. Failure to make these records available to an authorized representative of the board may be made grounds for disciplinary action. In any action brought and sustained by the board which involves a violation of this section and any regulation adopted thereto, the board may assess the licensee with the actual investigative costs incurred, not to exceed two thousand five hundred dollars (\$2,500). Failure to pay those costs may result in revocation of the license. Any moneys collected pursuant to this section shall be deposited in the respective fund of the board.

Added Stats 1984 ch 1490 § 2, effective September 27, 1984.

**§ 141. Disciplinary action by foreign jurisdiction; Grounds for disciplinary action by state licensing board**

(a) For any licensee holding a license issued by a board under the jurisdiction of the department, a disciplinary action taken by another state, by any agency of the federal government, or by another country for any act substantially related to the practice regulated by the California license, may be a ground for disciplinary action by the respective state licensing board. A certified copy of the record of the disciplinary action taken against the licensee by another state, an agency of the federal government, or another country shall be conclusive evidence of the events related therein.

(b) Nothing in this section shall preclude a board from applying a specific statutory provision in the licensing act administered by that board that provides for discipline based upon a disciplinary action taken against the licensee by another state, an agency of the federal government, or another country.

Added Stats 1994 ch 1275 § 2 (SB 2101).

**§ 142. Authority to synchronize renewal dates of licenses; Abandonment date for application; Delinquency fee**

This section shall apply to the bureaus and programs under the direct authority of the director, and to any board that, with the prior approval of the director, elects to have the department administer one or more of the licensing services set forth in this section.

(a) Notwithstanding any other provision of law, each bureau and program may synchronize the renewal dates of licenses granted to applicants with more than one license issued by the bureau or program. To the extent practicable, fees shall be prorated or adjusted so that no applicant shall be required to pay a greater or lesser fee than he or she would have been required to pay if the change in renewal dates had not occurred.

(b) Notwithstanding any other provision of law, the abandonment date for an application that has been returned to the applicant as incomplete shall be 12 months from the date of returning the application.

(c) Notwithstanding any other provision of law, a delinquency, penalty, or late fee shall be assessed if the renewal fee is not postmarked by the renewal expiration date.

Added Stats 1998 ch 970 § 2 (AB 2802).

**§ 143. Proof of license as condition of bringing action for collection of compensation**

(a) No person engaged in any business or profession for which a license is required under this code governing the department or any board, bureau, commission, committee, or program within the department, may bring or maintain any action, or recover in law or equity in any action, in any court of this state for the collection of compensation for the performance of any act or contract for which a license is required without alleging and proving that he or she was duly licensed at all times during the performance of that act or contract, regardless of the merits of the cause of action brought by the person.

(b) The judicial doctrine of substantial compliance shall not apply to this section.

(c) This section shall not apply to an act or contract that is considered to qualify as lawful practice of a licensed occupation or profession pursuant to Section 121.

Added Stats 1990 ch 1207 § 1.5 (AB 3242).

**§ 143.5. Provision in agreements to settle certain causes of action prohibited; Adoption of regulations; Exemptions**

(a) No licensee who is regulated by a board, bureau, or program within the Department of Consumer Affairs, nor an entity or person acting as an authorized agent of a licensee, shall include or permit to be included a provision in an agreement to settle a civil dispute, whether the agreement is made before or after the commencement of a civil action, that prohibits the other party in that dispute from contacting, filing a complaint with, or cooperating with the department, board, bureau, or program within the Department of Consumer Affairs that regulates the licensee or that requires the other party to withdraw a complaint from the department,

board, bureau, or program within the Department of Consumer Affairs that regulates the licensee. A provision of that nature is void as against public policy, and any licensee who includes or permits to be included a provision of that nature in a settlement agreement is subject to disciplinary action by the board, bureau, or program.

(b) Any board, bureau, or program within the Department of Consumer Affairs that takes disciplinary action against a licensee or licensees based on a complaint or report that has also been the subject of a civil action and that has been settled for monetary damages providing for full and final satisfaction of the parties may not require its licensee or licensees to pay any additional sums to the benefit of any plaintiff in the civil action.

(c) As used in this section, “board” shall have the same meaning as defined in Section 22, and “licensee” means a person who has been granted a license, as that term is defined in Section 23.7.

(d) Notwithstanding any other law, upon granting a petition filed by a licensee or authorized agent of a licensee pursuant to Section 11340.6 of the Government Code, a board, bureau, or program within the Department of Consumer Affairs may, based upon evidence and legal authorities cited in the petition, adopt a regulation that does both of the following:

(1) Identifies a code section or jury instruction in a civil cause of action that has no relevance to the board’s, bureau’s, or program’s enforcement responsibilities such that an agreement to settle such a cause of action based on that code section or jury instruction otherwise prohibited under subdivision (a) will not impair the board’s, bureau’s, or program’s duty to protect the public.

(2) Exempts agreements to settle such a cause of action from the requirements of subdivision (a).

(e) This section shall not apply to a licensee subject to Section 2220.7.

Added Stats 2012 ch 561 § 1 (AB 2570), effective January 1, 2013.

#### § 144. Requirement of fingerprints for criminal record checks; Applicability

(a) Notwithstanding any other provision of law, an agency designated in subdivision (b) shall require an applicant to furnish to the agency a full set of fingerprints for purposes of conducting criminal history record checks. Any agency designated in subdivision (b) may obtain and receive, at its discretion, criminal history information from the Department of Justice and the United States Federal Bureau of Investigation.

(b) Subdivision (a) applies to the following:

- (1) California Board of Accountancy.
- (2) State Athletic Commission.
- (3) Board of Behavioral Sciences.
- (4) Court Reporters Board of California.
- (5) State Board of Guide Dogs for the Blind.
- (6) California State Board of Pharmacy.
- (7) Board of Registered Nursing.
- (8) Veterinary Medical Board.
- (9) Board of Vocational Nursing and Psychiatric Technicians.
- (10) Respiratory Care Board of California.
- (11) Physical Therapy Board of California.
- (12) Physician Assistant Committee of the Medical Board of California.

(13) Speech-Language Pathology and Audiology and Hearing Aid Dispenser Board.

(14) Medical Board of California.

(15) State Board of Optometry.

(16) Acupuncture Board.

(17) Cemetery and Funeral Bureau.

(18) Bureau of Security and Investigative Services.

(19) Division of Investigation.

(20) Board of Psychology.

(21) California Board of Occupational Therapy.

(22) Structural Pest Control Board.

(23) Contractors’ State License Board.

(24) Naturopathic Medicine Committee.

(25) Professional Fiduciaries Bureau.

(26) Board for Professional Engineers, Land Surveyors, and Geologists.

(c) For purposes of paragraph (26) of subdivision (b), the term “applicant” shall be limited to an initial applicant who has never been registered or licensed by the board or to an applicant for a new licensure or registration category.

Added Stats 1997 ch 758 § 2 (SB 1346). Amended Stats 2000 ch 697 § 1.2 (SB 1046), operative January 1, 2001; Stats 2001 ch 159 § 4 (SB 662), ch 687 § 2 (AB 1409) (ch 687 prevails); Stats 2002 ch 744 § 1 (SB 1953), ch 825 § 1 (SB 1952); Stats 2003 ch 485 § 2 (SB 907), ch 789 § 1 (SB 364), ch 874 § 1 (SB 363); Stats 2004 ch 909 § 1.2 (SB 136), effective September 30, 2004; Stats 2009 ch 308 § 4 (SB 819), effective January 1, 2010; Stats 2011 ch 448 § 1 (SB 543), effective January 1, 2012.

## CHAPTER 1.5

### Unlicensed Activity Enforcement

#### Section

145. Legislative findings and declarations

146. Violations of specified authorization statutes as infractions; Punishment

146.5. [Section repealed 2008.]

147. Authority to issue written notice to appear in court

148. Establishment of administrative citation system

149. Notice to cease advertising in telephone directory; Contest and hearing; Disconnection of service

#### § 145. Legislative findings and declarations

The Legislature finds and declares that:

(a) Unlicensed activity in the professions and vocations regulated by the Department of Consumer Affairs is a threat to the health, welfare, and safety of the people of the State of California.

(b) The law enforcement agencies of the state should have sufficient, effective, and responsible means available to enforce the licensing laws of the state.

(c) The criminal sanction for unlicensed activity should be swift, effective, appropriate, and create a strong incentive to obtain a license.

Added Stats 1992 ch 1135 § 2 (SB 2044).

#### § 146. Violations of specified authorization statutes as infractions; Punishment

(a) Notwithstanding any other provision of law, a violation of any code section listed in subdivision (c) is an infraction subject to the procedures described in Sections 19.6 and 19.7 of the Penal Code when either of the following applies:

(1) A complaint or a written notice to appear in court pursuant to Chapter 5c (commencing with Section 853.5)

of Title 3 of Part 2 of the Penal Code is filed in court charging the offense as an infraction unless the defendant, at the time he or she is arraigned, after being advised of his or her rights, elects to have the case proceed as a misdemeanor.

(2) The court, with the consent of the defendant and the prosecution, determines that the offense is an infraction in which event the case shall proceed as if the defendant has been arraigned on an infraction complaint.

(b) Subdivision (a) does not apply to a violation of the code sections listed in subdivision (c) if the defendant has had his or her license, registration, or certificate previously revoked or suspended.

(c) The following sections require registration, licensure, certification, or other authorization in order to engage in certain businesses or professions regulated by this code:

- (1) Sections 2052 and 2054.
- (2) Section 2630.
- (3) Section 2903.
- (4) Section 3660.
- (5) Sections 3760 and 3761.
- (6) Section 4080.
- (7) Section 4825.
- (8) Section 4935.
- (9) Section 4980.
- (10) Section 4996.
- (11) Section 5536.
- (12) Section 6704.
- (13) Section 6980.10.
- (14) Section 7317.
- (15) Section 7502 or 7592.
- (16) Section 7520.
- (17) Section 7617 or 7641.
- (18) Subdivision (a) of Section 7872.
- (19) Section 8016.
- (20) Section 8505.
- (21) Section 8725.
- (22) Section 9681.
- (23) Section 9840.
- (24) Subdivision (c) of Section 9891.24.
- (25) Section 19049.

(d) Notwithstanding any other provision of law, a violation of any of the sections listed in subdivision (c), which is an infraction, is punishable by a fine of not less than two hundred fifty dollars (\$250) and not more than one thousand dollars (\$1,000). No portion of the minimum fine may be suspended by the court unless as a condition of that suspension the defendant is required to submit proof of a current valid license, registration, or certificate for the profession or vocation which was the basis for his or her conviction.

Added Stats 1992 ch 1135 § 2 (SB 2044). Amended Stats 1993 ch 1264 § 2 (SB 574), ch 1267 § 2.5 (SB 916); Stats 1994 ch 26 § 8 (AB 1807), effective March 30, 1994; Stats 1997 ch 78 § 2 (AB 71); Stats 2001 ch 357 § 1 (AB 1560); Stats 2003 ch 485 § 3 (SB 907); Stats 2009 ch 308 § 5 (SB 819), effective January 1, 2010, ch 310 § 3.5 (AB 48), effective January 1, 2010.

**§ 146.5. [Section repealed 2008.]**

Added Stats 1993 ch 1265 § 1 (SB 798). Amended Stats 1997 ch 401 § 1 (SB 780); Stats 2001 ch 357 § 2 (AB 1560); Stats 2002 ch 405 § 2 (AB 2973). Repealed January 1, 2008, by its own terms. The repealed section related to violations of specified authorization statutes.

**§ 147. Authority to issue written notice to appear in court**

(a) Any employee designated by the director shall have the authority to issue a written notice to appear in court pursuant to Chapter 5c (commencing with Section 853.5) of Title 3 of Part 2 of the Penal Code. Employees so designated are not peace officers and are not entitled to safety member retirement benefits, as a result of such designation. The employee's authority is limited to the issuance of written notices to appear for infraction violations of provisions of this code and only when the violation is committed in the presence of the employee.

(b) There shall be no civil liability on the part of, and no cause of action shall arise against, any person, acting pursuant to subdivision (a) and within the scope of his or her authority, for false arrest or false imprisonment arising out of any arrest which is lawful or which the person, at the time of such arrest, had reasonable cause to believe was lawful.

Added Stats 1992 ch 1135 § 2 (SB 2044).

**§ 148. Establishment of administrative citation system**

Any board, bureau, or commission within the department may, in addition to the administrative citation system authorized by Section 125.9, also establish, by regulation, a similar system for the issuance of an administrative citation to an unlicensed person who is acting in the capacity of a licensee or registrant under the jurisdiction of that board, bureau, or commission. The administrative citation system authorized by this section shall meet the requirements of Section 125.9 and may not be applied to an unlicensed person who is otherwise exempted from the provisions of the applicable licensing act. The establishment of an administrative citation system for unlicensed activity does not preclude the use of other enforcement statutes for unlicensed activities at the discretion of the board, bureau, or commission.

Added Stats 1992 ch 1135 § 2 (SB 2044).

**§ 149. Notice to cease advertising in telephone directory; Contest and hearing; Disconnection of service**

(a) If, upon investigation, an agency designated in subdivision (e) has probable cause to believe that a person is advertising in a telephone directory with respect to the offering or performance of services, without being properly licensed by or registered with the agency to offer or perform those services, the agency may issue a citation under Section 148 containing an order of correction that requires the violator to do both of the following:

- (1) Cease the unlawful advertising.
- (2) Notify the telephone company furnishing services to the violator to disconnect the telephone service furnished to any telephone number contained in the unlawful advertising.

(b) This action is stayed if the person to whom a citation is issued under subdivision (a) notifies the agency in writing that he or she intends to contest the citation. The agency shall afford an opportunity for a hearing, as specified in Section 125.9.

(c) If the person to whom a citation and order of correction is issued under subdivision (a) fails to comply with the order of correction after that order is final, the agency shall inform the Public Utilities Commission of the violation and the Public Utilities Commission shall require the telephone corporation furnishing services to that person to disconnect the telephone service furnished to any telephone number contained in the unlawful advertising.

(d) The good faith compliance by a telephone corporation with an order of the Public Utilities Commission to terminate service issued pursuant to this section shall constitute a complete defense to any civil or criminal action brought against the telephone corporation arising from the termination of service.

(e) Subdivision (a) shall apply to the following boards, bureaus, committees, commissions, or programs:

- (1) The Bureau of Barbering and Cosmetology.
- (2) The Cemetery and Funeral Bureau.
- (3) The Veterinary Medical Board.
- (4) The Landscape Architects Technical Committee.
- (5) The California Board of Podiatric Medicine.
- (6) The Respiratory Care Board of California.
- (7) The Bureau of Electronic and Appliance Repair, Home Furnishings, and Thermal Insulation.
- (8) The Bureau of Security and Investigative Services.
- (9) The Bureau of Automotive Repair.
- (10) The California Architects Board.
- (11) The Speech-Language Pathology and Audiology Board.
- (12) The Board for Professional Engineers and Land Surveyors.
- (13) The Board of Behavioral Sciences.
- (14) The Structural Pest Control Board.
- (15) The Acupuncture Board.
- (16) The Board of Psychology.
- (17) The California Board of Accountancy.
- (18) The Naturopathic Medicine Committee.
- (19) The Physical Therapy Board of California.
- (20) The Bureau for Private Postsecondary Education.
- (21) The Bureau of Real Estate.

Added Stats 1992 ch 1135 § 2 (SB 2044). Amended Stats 1993 ch 1263 § 3 (AB 936); Stats 1994 ch 26 § 9 (AB 1807), effective March 30, 1994, ch 1274 § 1.5 (SB 2039); Stats 1995 ch 60 § 4 (SB 42), effective July 6, 1995; Stats 1998 ch 59 § 5 (AB 969); Stats 2000 ch 1054 § 3 (SB 1863), ch 1055 § 2 (AB 2889), effective September 30, 2000, ch 1055 § 2.5 (AB 2889), effective September 30, 2000; Stats 2003 ch 485 § 4 (SB 907); Stats 2009–2010 4th Ex Sess ch 18 § 3 (AB 20XXXX), effective October 23, 2009; Stats 2009 ch 308 § 6 (SB 819), effective January 1, 2010, ch 309 § 2 (AB 1535), effective January 1, 2010, ch 310 § 4.7 (AB 48), effective January 1, 2010. See this section as modified in Governor's Reorganization Plan No. 2 § 4 of 2012. Amended Stats 2013 ch 352 § 5 (AB 1317), effective September 26, 2013, operative July 1, 2013, ch 436 § 1 (SB 269), effective January 1, 2014.

## CHAPTER 3

### Funds of the Department

#### Section

200. Deposit of revenues, etc.; Refunds  
206. Dishonored check tendered for payment of fine, fee, or penalty

#### § 200. Deposit of revenues, etc.; Refunds

Notwithstanding any other provisions of this code, any revenues, collections, or receipts accruing to any board in the department may, in the manner determined

by the director and with the consent of the board concerned, be received and deposited by the department, and in such case shall be accounted for to the board and remitted by the department to the State Treasury in accordance with law for credit to the fund of such board. Notwithstanding Section 158 of this code, all refunds shall be made by the department with the consent of the board.

Enacted Stats 1937. Amended Stats 1959 ch 1426 § 1.

#### § 206. Dishonored check tendered for payment of fine, fee, or penalty

Notwithstanding any other provision of law, any person tendering a check for payment of a fee, fine, or penalty that was subsequently dishonored, shall not be granted a license, or other authority that they were seeking, until the applicant pays the amount outstanding from the dishonored payment together with the applicable fee, including any delinquency fee. The board may require the person whose check was returned unpaid to make payment of all fees by cashier's check or money order.

Added Stats 1994 ch 26 § 12 (AB 1807), effective March 30, 1994.

## CHAPTER 4

### Consumer Affairs

#### ARTICLE 1

#### General Provisions and Definitions

##### Section

300. Citation of chapter  
301. Declaration of intent  
302. Definitions  
303. Division of Consumer Services; Chief

#### § 300. Citation of chapter

This chapter may be cited as the Consumer Affairs Act.

Added Stats 1970 ch 1394 § 3, operative July 1, 1971.

#### § 301. Declaration of intent

It is the intent of the Legislature and the purpose of this chapter to promote and protect the interests of the people as consumers. The Legislature finds that vigorous representation and protection of consumer interests are essential to the fair and efficient functioning of a free enterprise market economy. The Legislature declares that government advances the interests of consumers by facilitating the proper functioning of the free enterprise market economy through (a) educating and informing the consumer to insure rational consumer choice in the marketplace; (b) protecting the consumer from the sale of goods and services through the use of deceptive methods, acts, or practices which are inimical to the general welfare of consumers; (c) fostering competition; and (d) promoting effective representation of consumers' interests in all branches and levels of government.

Added Stats 1970 ch 1394 § 3, operative July 1, 1971. Amended Stats 1975 ch 1262 § 1.

#### § 302. Definitions

As used in this chapter, the following terms have the following meanings:

(a) "Department" means the Department of Consumer Affairs.

(b) "Director" means the Director of the Department of Consumer Affairs.

(c) "Consumer" means any individual who seeks or acquires, by purchase or lease, any goods, services, money, or credit for personal, family, or household purposes.

(d) "Person" means an individual, partnership, corporation, limited liability company, association, or other group, however organized.

(e) "Individual" does not include a partnership, corporation, association, or other group, however organized.

(f) "Division" means the Division of Consumer Services.

(g) "Interests of consumers" is limited to the cost, quality, purity, safety, durability, performance, effectiveness, dependability, availability, and adequacy of choice of goods and services offered or furnished to consumers and the adequacy and accuracy of information relating to consumer goods, services, money, or credit (including labeling, packaging, and advertising of contents, qualities, and terms of sales).

Added Stats 1970 ch 1394 § 3, operative July 1, 1971. Amended Stats 1972 ch 808 § 1; Stats 1975 ch 1262 § 2; Stats 1994 ch 1010 § 2 (SB 2053).

**§ 303. Division of Consumer Services; Chief**

There is in the department a Division of Consumer Services under the supervision and control of a chief. The chief shall be appointed by the Governor and shall serve at his pleasure. His compensation shall be fixed by the director in accordance with law.

Added Stats 1972 ch 808 § 2.

**ARTICLE 2**

**Director and Employees**

Section

- 305. Administration of chapter
- 306. Employment matters
- 307. Experts and consultants

**§ 305. Administration of chapter**

The director shall administer and enforce the provisions of this chapter. Every power granted or duty imposed upon the director under this chapter may be exercised or performed in the name of the director by a deputy or assistant director or the chief of the department's Division of Consumer Services, subject to such conditions and limitations as the director may prescribe.

Added Stats 1970 ch 1394 § 3, operative July 1, 1971. Amended Stats 1971 ch 114 § 1, effective June 2, 1971, operative July 1, 1971.

**§ 306. Employment matters**

The director, in accordance with the State Civil Service Act, may appoint and fix the compensation of such clerical or other personnel as may be necessary to carry out the provisions of this chapter. All such personnel shall perform their respective duties under the supervision and the direction of the director.

Added Stats 1970 ch 1394 § 3, operative July 1, 1971.

**§ 307. Experts and consultants**

The director may contract for the services of experts and consultants where necessary to carry out the provisions

of this chapter and may provide compensation and reimbursement of expenses for such experts and consultants in accordance with state law.

Added Stats 1975 ch 1262 § 3.

**ARTICLE 3**

**Powers and Duties**

Section

- 310. Director's powers and duties
- 311. Interdepartmental committee
- 312. Report to Governor and Legislature
- 313. Establishment of library
- 313.1. Compliance with section as requirement for effectiveness of specified rules or regulations; Submission of records; Authority for disapproval
- 313.2. Adoption of regulations in conformance with Americans with Disabilities Act
- 313.5. Publication of consumer information bibliography

**§ 310. Director's powers and duties**

The director shall have the following powers and it shall be his duty to:

(a) Recommend and propose the enactment of such legislation as necessary to protect and promote the interests of consumers.

(b) Represent the consumer's interests before federal and state legislative hearings and executive commissions.

(c) Assist, advise, and cooperate with federal, state, and local agencies and officials to protect and promote the interests of consumers.

(d) Study, investigate, research, and analyze matters affecting the interests of consumers.

(e) Hold public hearings, subpoena witnesses, take testimony, compel the production of books, papers, documents, and other evidence, and call upon other state agencies for information.

(f) Propose and assist in the creation and development of consumer education programs.

(g) Promote ethical standards of conduct for business and consumers and undertake activities to encourage public responsibility in the production, promotion, sale and lease of consumer goods and services.

(h) Advise the Governor and Legislature on all matters affecting the interests of consumers.

(i) Exercise and perform such other functions, powers and duties as may be deemed appropriate to protect and promote the interests of consumers as directed by the Governor or the Legislature.

(j) Maintain contact and liaison with consumer groups in California and nationally.

Added Stats 1970 ch 1394 § 3, operative July 1, 1971. Amended Stats 1975 ch 1262 § 4.

**§ 311. Interdepartmental committee**

The director may create an interdepartmental committee to assist and advise him in the implementation of his duties. The members of such committee shall consist of the heads of state departments, or their designees. Members of such committee shall serve without compensation but shall be reimbursed for the expenses actually and necessarily incurred by them in the performance of their duties.

Added Stats 1970 ch 1394 § 3, operative July 1, 1971.

### § 312. Report to Governor and Legislature

The director shall submit to the Governor and the Legislature on or before January 1, 2003, and annually thereafter, a report of programmatic and statistical information regarding the activities of the department and its constituent entities. The report shall include information concerning the director's activities pursuant to Section 326, including the number and general patterns of consumer complaints and the action taken on those complaints.

Added Stats 1970 ch 1394 § 3, operative July 1, 1971. Amended Stats 1975 ch 1262 § 5; Stats 1998 ch 829 § 1 SB 1652; Stats 2002 ch 405 § 3 (AB 2973).

### § 313. Establishment of library

The director shall provide for the establishment of a comprehensive library of books, documents, studies, and other materials relating to consumers and consumer problems.

Added Stats 1972 ch 1251 § 1. Amended Stats 1975 ch 1262 § 6.

#### § 313.1. Compliance with section as requirement for effectiveness of specified rules or regulations; Submission of records; Authority for disapproval

(a) Notwithstanding any other provision of law to the contrary, no rule or regulation, except those relating to examinations and qualifications for licensure, and no fee change proposed or promulgated by any of the boards, commissions, or committees within the department, shall take effect pending compliance with this section.

(b) The director shall be formally notified of and shall be provided a full opportunity to review, in accordance with the requirements of Article 5 (commencing with Section 11346) of Chapter 3.5 of Part 1 of Division 3 of Title 2 of the Government Code, and this section, all of the following:

(1) All notices of proposed action, any modifications and supplements thereto, and the text of proposed regulations.

(2) Any notices of sufficiently related changes to regulations previously noticed to the public, and the text of proposed regulations showing modifications to the text.

(3) Final rulemaking records.

(c) The submission of all notices and final rulemaking records to the director and the completion of the director's review, as authorized by this section, shall be a precondition to the filing of any rule or regulation with the Office of Administrative Law. The Office of Administrative Law shall have no jurisdiction to review a rule or regulation subject to this section until after the completion of the director's review and only then if the director has not disapproved it. The filing of any document with the Office of Administrative Law shall be accompanied by a certification that the board, commission, or committee has complied with the requirements of this section.

(d) Following the receipt of any final rulemaking record subject to subdivision (a), the director shall have the authority for a period of 30 days to disapprove a proposed rule or regulation on the ground that it is injurious to the public health, safety, or welfare.

(e) Final rulemaking records shall be filed with the director within the one-year notice period specified in Section 11346.4 of the Government Code. If necessary for

compliance with this section, the one-year notice period may be extended, as specified by this subdivision.

(1) In the event that the one-year notice period lapses during the director's 30-day review period, or within 60 days following the notice of the director's disapproval, it may be extended for a maximum of 90 days.

(2) If the director approves the final rulemaking record or declines to take action on it within 30 days, the board, commission, or committee shall have five days from the receipt of the record from the director within which to file it with the Office of Administrative Law.

(3) If the director disapproves a rule or regulation, it shall have no force or effect unless, within 60 days of the notice of disapproval, (A) the disapproval is overridden by a unanimous vote of the members of the board, commission, or committee, and (B) the board, commission, or committee files the final rulemaking record with the Office of Administrative Law in compliance with this section and the procedures required by Chapter 3.5 (commencing with Section 11340) of Part 1 of Division 3 of Title 2 of the Government Code.

(f) Nothing in this section shall be construed to prohibit the director from affirmatively approving a proposed rule, regulation, or fee change at any time within the 30-day period after it has been submitted to him or her, in which event it shall become effective upon compliance with this section and the procedures required by Chapter 3.5 (commencing with Section 11340) of Part 1 of Division 3 of Title 2 of the Government Code.

Added Stats 1972 ch 1251 § 1, as B & P C § 313. Amended and Renumbered by Stats 1973 ch 40 § 1, effective May 10, 1973. Amended Stats 1984 ch 144 § 4; Stats 1991 ch 654 § 4 (AB 1893); Stats 1992 ch 1289 § 2 (AB 2743); Stats 1994 ch 26 § 13 (AB 1807), effective March 30, 1994.

#### § 313.2. Adoption of regulations in conformance with Americans with Disabilities Act

The director shall adopt regulations to implement, interpret, and make specific the provisions of the Americans with Disabilities Act (P.L. 101-336), as they relate to the examination process for professional licensing and certification programs under the purview of the department.

Added Stats 1992 ch 1289 § 3 (AB 2743).

#### § 313.5. Publication of consumer information bibliography

The director shall periodically publish a bibliography of consumer information available in the department library and elsewhere. Such bibliography shall be sent to subscribers upon payment of a reasonable fee therefor.

Added Stats 1972 ch 1251 § 2. Amended Stats 1975 ch 1262 § 7.

## ARTICLE 4

### Representation of Consumers

Section

320. Intervention in administrative or judicial proceedings

321. Commencement of legal proceedings

#### § 320. Intervention in administrative or judicial proceedings

Whenever there is pending before any state commission, regulatory agency, department, or other state

agency, or any state or federal court or agency, any matter or proceeding which the director finds may affect substantially the interests of consumers within California, the director, or the Attorney General, may intervene in such matter or proceeding in any appropriate manner to represent the interests of consumers. The director, or any officer or employee designated by the director for that purpose, or the Attorney General, may thereafter present to such agency, court, or department, in conformity with the rules of practice and procedure thereof, such evidence and argument as he shall determine to be necessary, for the effective protection of the interests of consumers.

Added Stats 1970 ch 1394 § 3, operative July 1, 1971. Amended Stats 1975 ch 1262 § 8.

**§ 321. Commencement of legal proceedings**

Whenever it appears to the director that the interests of the consumers of this state are being damaged, or may be damaged, by any person who engaged in, or intends to engage in, any acts or practices in violation of any law of this state, or any federal law, the director or any officer or employee designated by the director, or the Attorney General, may commence legal proceedings in the appropriate forum to enjoin such acts or practices and may seek other appropriate relief on behalf of such consumers.

Added Stats 1975 ch 1262 § 9.

**ARTICLE 5**

**Consumer Complaints**

Section

325. Actionable complaints

326. Proceedings on receipt of complaint

**§ 325. Actionable complaints**

It shall be the duty of the director to receive complaints from consumers concerning (a) unfair methods of competition and unfair or deceptive acts or practices undertaken by any person in the conduct of any trade or commerce; (b) the production, distribution, sale, and lease of any goods and services undertaken by any person which may endanger the public health, safety, or welfare; (c) violations of provisions of this code relating to businesses and professions licensed by any agency of the department, and regulations promulgated pursuant thereto; and (d) other matters consistent with the purposes of this chapter, whenever appropriate.

Added Stats 1970 ch 1394 § 3, operative July 1, 1971.

**§ 326. Proceedings on receipt of complaint**

(a) Upon receipt of any complaint pursuant to Section 325, the director may notify the person against whom the complaint is made of the nature of the complaint and may request appropriate relief for the consumer.

(b) The director shall also transmit any valid complaint to the local, state or federal agency whose authority provides the most effective means to secure the relief.

The director shall, if appropriate, advise the consumer of the action taken on the complaint and of any other means which may be available to the consumer to secure relief.

(c) If the director receives a complaint or receives information from any source indicating a probable violation of any law, rule, or order of any regulatory agency of the state, or if a pattern of complaints from consumers develops, the director shall transmit any complaint he or she considers to be valid to any appropriate law enforcement or regulatory agency and any evidence or information he or she may have concerning the probable violation or pattern of complaints or request the Attorney General to undertake appropriate legal action. It shall be the continuing duty of the director to discern patterns of complaints and to ascertain the nature and extent of action taken with respect to the probable violations or pattern of complaints.

Added Stats 1970 ch 1394 § 3, operative July 1, 1971. Amended Stats 1978 ch 1161 § 8; Stats 1989 ch 1360 § 1.

**CHAPTER 6**

**Public Members**

Section

450. Qualifications generally

450.2. Avoiding conflict of interest

450.3. Conflicting pecuniary interests

450.5. Prior industrial and professional pursuits

450.6. Age

451. Delegation of duties

452. "Board"

**§ 450. Qualifications generally**

In addition to the qualifications provided in the respective chapters of this code, a public member or a lay member of any board shall not be, nor shall he have been within the period of five years immediately preceding his appointment, any of the following:

(a) An employer, or an officer, director, or substantially fulltime representative of an employer or group of employers, of any licentiate of such board, except that this shall not preclude the appointment of a person which maintains infrequent employer status with such licentiate, or maintains a client, patient, or customer relationship with any such licentiate which does not constitute more than 2 percent of the practice or business of the licentiate.

(b) A person maintaining a contractual relationship with a licentiate of such board, which would constitute more than 2 percent of the practice or business of any such licentiate, or an officer, director, or substantially full-time representative of such person or group of persons.

(c) An employee of any licentiate of such board, or a representative of such employee, except that this shall not preclude the appointment of a person who maintains an infrequent employee relationship or a person rendering professional or related services to a licentiate if such employment or service does not constitute more than 2 percent of the employment or practice of the member of the board.

Added Stats 1961 ch 2232 § 2.

**§ 450.2. Avoiding conflict of interest**

In order to avoid a potential for a conflict of interest, a public member of a board shall not:

(a) Be a current or past licensee of that board.



(b) Be a close family member of a licensee of that board.

Added Stats 2002 ch 1150 § 1.2 (SB 1955).

#### § 450.3. Conflicting pecuniary interests

No public member shall either at the time of his appointment or during his tenure in office have any financial interest in any organization subject to regulation by the board, commission or committee of which he is a member.

Added Stats 1972 ch 1032 § 1.

#### § 450.5. Prior industrial and professional pursuits

A public member, or a lay member, at any time within five years immediately preceding his or her appointment, shall not have been engaged in pursuits which lie within the field of the industry or profession, or have provided representation to the industry or profession, regulated by the board of which he or she is a member, nor shall he or she engage in those pursuits or provide that representation during his or her term of office.

Added Stats 1961 ch 2232 § 2. Amended Stats 2003 ch 563 § 2 (AB 827).

#### § 450.6. Age

Notwithstanding any other section of law, a public member may be appointed without regard to age so long as the public member has reached the age of majority prior to appointment.

Added Stats 1976 ch 1188 § 1.3.

#### § 451. Delegation of duties

If any board shall as a part of its functions delegate any duty or responsibility to be performed by a single member of such board, such delegation shall not be made solely to any public member or any lay member of the board in any of the following instances:

(a) The actual preparation of, the administration of, and the grading of, examinations.

(b) The inspection or investigation of licentiates, the manner or method of practice or doing business, or their place of practice or business.

Nothing in this section shall be construed as precluding a public member or a lay member from participating in the formation of policy relating to the scope of the activities set forth in subdivisions (a) and (b) or in the approval, disapproval or modification of the action of its individual members, nor preclude such member from participating as a member of a subcommittee consisting of more than one member of the board in the performance of any duty.

Added Stats 1961 ch 2232 § 2.

#### § 452. "Board"

"Board," as used in this chapter, includes a board, advisory board, commission, examining committee, committee or other similarly constituted body exercising powers under this code.

Added Stats 1961 ch 2232 § 2. Amended Stats 1976 ch 1188 § 1.5.

## CHAPTER 7

### Licensee

Section

460. Powers of local governmental entities

Section

461. Asking applicant to reveal arrest record prohibited

462. Inactive category of licensure

#### § 460. Powers of local governmental entities

(a) No city or county shall prohibit a person or group of persons, authorized by one of the agencies in the Department of Consumer Affairs by a license, certificate, or other such means to engage in a particular business, from engaging in that business, occupation, or profession or any portion thereof.

(b) No city, county, or city and county shall prohibit a healing arts professional licensed with the state under Division 2 (commencing with Section 500) from engaging in any act or performing any procedure that falls within the professionally recognized scope of practice of that licensee.

(1) This subdivision shall not be construed to prohibit the enforcement of a local ordinance in effect prior to January 1, 2010, related to any act or procedure that falls within the professionally recognized scope of practice of a healing arts professional licensed under Division 2 (commencing with Section 500).

(2) This subdivision shall not be construed to prevent a city, county, or city and county from adopting or enforcing any local ordinance governing zoning, business licensing, or reasonable health and safety requirements for establishments or businesses of a healing arts professional licensed under Division 2 (commencing with Section 500).

(c) Nothing in this section shall prohibit any city, county, or city and county from levying a business license tax solely for revenue purposes, nor any city or county from levying a license tax solely for the purpose of covering the cost of regulation.

Added Stats 1967 ch 1095 § 1. Amended Stats 1971 ch 716 § 24; Stats 2009 ch 16 § 1 (SB 762), effective January 1, 2010.

#### § 461. Asking applicant to reveal arrest record prohibited

No public agency, state or local, shall, on an initial application form for any license, certificate or registration, ask for or require the applicant to reveal a record of arrest that did not result in a conviction or a plea of nolo contendere. A violation of this section is a misdemeanor.

This section shall apply in the case of any license, certificate or registration provided for by any law of this state or local government, including, but not limited to, this code, the Corporations Code, the Education Code, and the Insurance Code.

Added Stats 1975 ch 883 § 1.

#### § 462. Inactive category of licensure

(a) Any of the boards, bureaus, commissions, or programs within the department may establish, by regulation, a system for an inactive category of licensure for persons who are not actively engaged in the practice of their profession or vocation.

(b) The regulation shall contain the following provisions:

(1) The holder of an inactive license issued pursuant to this section shall not engage in any activity for which a license is required.

(2) An inactive license issued pursuant to this section shall be renewed during the same time period in which an active license is renewed. The holder of an inactive license need not comply with any continuing education requirement for renewal of an active license.

(3) The renewal fee for a license in an active status shall apply also for a renewal of a license in an inactive status, unless a lesser renewal fee is specified by the board.

(4) In order for the holder of an inactive license issued pursuant to this section to restore his or her license to an active status, the holder of an inactive license shall comply with all the following:

(A) Pay the renewal fee.

(B) If the board requires completion of continuing education for renewal of an active license, complete continuing education equivalent to that required for renewal of an active license, unless a different requirement is specified by the board.

(c) This section shall not apply to any healing arts board as specified in Section 701.

Added Stats 1994 ch 26 § 14 (AB 1807), effective March 30, 1994.

## CHAPTER 9

### Certification of Third-Party Dispute Resolution Processes for New Motor Vehicles

Section

472. Definitions

472.1. Program for certifying third party dispute resolution processes used for arbitration of disputes

472.2. Availability to buyers or lessees of new motor vehicle; Application for certification; Final determination

472.5. Certification Account; Statement of motor vehicles distributed; Fees; Notification of amount to fund program; Adoption of regulations

#### § 472. Definitions

Unless the context requires otherwise, the following definitions govern the construction of this chapter:

(a) "New motor vehicle" means a new motor vehicle as defined in paragraph (2) of subdivision (e) of Section 1793.22 of the Civil Code.

(b) "Manufacturer" means a new motor vehicle manufacturer, manufacturer branch, distributor, or distributor branch required to be licensed pursuant to Article 1 (commencing with Section 11700) of Chapter 4 of Division 5 of the Vehicle Code.

(c) "Qualified third party dispute resolution process" means a third party dispute resolution process which operates in compliance with subdivision (d) of Section 1793.22 of the Civil Code and this chapter and which has been certified by the department pursuant to this chapter.

Added Stats 1987 ch 1280 § 1, operative July 1, 1988, as B & P C § 9889.70. Amended and Renumbered by Stats 1991 ch 689 § 3 (AB 211). Amended Stats 1992 ch 1232 § 1 (SB 1762).

#### § 472.1. Program for certifying third party dispute resolution processes used for arbitration of disputes

The department shall establish a program for certifying each third-party dispute resolution process used for

the arbitration of disputes pursuant to subdivision (c) of Section 1793.22 of the Civil Code. In establishing the program, the department shall do all of the following:

(a) Prescribe and provide forms to be used to apply for certification under this chapter.

(b) Establish a set of minimum standards which shall be used to determine whether a third-party dispute resolution process is in substantial compliance with subdivision (d) of Section 1793.22 of the Civil Code and this chapter.

(c) Prescribe the information which each manufacturer, or other entity, that operates a third-party dispute resolution process shall provide the department in the application for certification. In prescribing the information to accompany the application for certification, the department shall require the manufacturer, or other entity, to provide only that information which the department finds is reasonably necessary to enable the department to determine whether the third-party dispute resolution process is in substantial compliance with subdivision (d) of Section 1793.22 of the Civil Code and this chapter.

(d) Prescribe the information that each qualified third-party dispute resolution process shall provide the department, and the time intervals at which the information shall be required, to enable the department to determine whether the qualified third-party dispute resolution process continues to operate in substantial compliance with subdivision (d) of Section 1793.22 of the Civil Code and this chapter.

Added Stats ch 1280 § 1, operative July 1, 1988, as B & P C § 9889.71. Amended Stats 1988 ch 841 § 1. Amended and Renumbered by Stats 1991 ch 689 § 4 (AB 211). Amended Stats 1992 ch 1232 § 2 (SB 1762).

#### § 472.2. Availability to buyers or lessees of new motor vehicle; Application for certification; Final determination

(a) Each manufacturer may establish, or otherwise make available to buyers or lessees of new motor vehicles, a qualified third-party dispute resolution process for the resolution of disputes pursuant to subdivision (c) of Section 1793.22 of the Civil Code. A manufacturer that itself operates the third-party dispute resolution process shall apply to the department for certification of that process. If the manufacturer makes the third-party dispute resolution process available to buyers or lessees of new motor vehicles through contract or other arrangement with another entity, that entity shall apply to the department for certification. An entity that operates a third-party dispute resolution process for more than one manufacturer shall make a separate application for certification for each manufacturer that uses that entity's third-party dispute resolution process. The application for certification shall be accompanied by the information prescribed by the department.

(b) The department shall review the application and accompanying information and, after conducting an on-site inspection, shall determine whether the third-party dispute resolution process is in substantial compliance with subdivision (d) of Section 1793.22 of the Civil Code and this chapter. If the department determines that the process is in substantial compliance, the department shall certify the process. If the department determines that the process is not in substantial compliance, the

department shall deny certification and shall state, in writing, the reasons for denial and the modifications in the operation of the process that are required in order for the process to be certified.

(c) The department shall make a final determination whether to certify a third-party dispute resolution process or to deny certification not later than 90 calendar days following the date the department accepts the application for certification as complete.

Added Stats 1987 ch 1280 § 1, operative July 1, 1988, as B & P C § 9889.72. Amended Stats 1988 ch 841 § 2. Amended and Renumbered by Stats 1991 ch 689 § 5 (AB 211). Amended Stats 1992 ch 1232 § 3 (SB 1762).

**§ 472.5. Certification Account; Statement of motor vehicles distributed; Fees; Notification of amount to fund program; Adoption of regulations**

The New Motor Vehicle Board in the Department of Motor Vehicles shall, in accordance with the procedures prescribed in this section, administer the collection of fees for the purposes of fully funding the administration of this chapter.

(a) Fees collected pursuant to this section shall be deposited in the Certification Account in the Consumer Affairs Fund and shall be available, upon appropriation by the Legislature, exclusively to pay the expenses incurred by the department in administering this chapter and to pay the New Motor Vehicle Board as provided in Section 3016 of the Vehicle Code. If, at the conclusion of any fiscal year, the amount of fees collected exceeds the amount of expenditures for that purpose during that fiscal year, the surplus in the Certification Account shall be carried over into the succeeding fiscal year.

(b) Beginning July 1, 1988, and on or before May 1 of each calendar year thereafter, every manufacturer shall file with the New Motor Vehicle Board a statement of the number of motor vehicles sold, leased, or otherwise distributed by or for the manufacturer in this state during the preceding calendar year, and shall, upon written notice delivered to the manufacturer by certified mail, return receipt requested, pay to the New Motor Vehicle Board a fee, not to exceed one dollar (\$1) for each motor vehicle sold, leased, or distributed by or for the manufacturer in this state during the preceding calendar year. The total fee paid by each manufacturer shall be rounded to the nearest dollar in the manner described in Section 9559 of the Vehicle Code. Not more than one

dollar (\$1) shall be charged, collected, or received from any one or more manufacturers pursuant to this subdivision with respect to the same motor vehicle.

(c)(1) The fee required by subdivision (b) is due and payable not later than 30 days after the manufacturer has received notice of the amount due and is delinquent after that time. A penalty of 10 percent of the amount delinquent shall be added to that amount, if the delinquency continues for more than 30 days.

(2) If a manufacturer fails to file the statement required by subdivision (b) by the date specified, the New Motor Vehicle Board shall assess the amount due from the manufacturer by using as the number of motor vehicles sold, leased, or otherwise distributed by or for the manufacturer in this state during the preceding calendar year the total number of new registrations of all motor vehicles sold, leased, or otherwise distributed by or for the manufacturer during the preceding calendar year.

(d) On or before February 1 of each year, the department shall notify the New Motor Vehicle Board of the dollar amount necessary to fully fund the program established by this chapter during the following fiscal year. The New Motor Vehicle Board shall use this information in calculating the amounts of the fees to be collected from manufacturers pursuant to this section.

(e) For purposes of this section, “motor vehicle” means a new passenger or commercial motor vehicle of a kind that is required to be registered under the Vehicle Code, but the term does not include a motorcycle, a motor home, or any vehicle whose gross weight exceeds 10,000 pounds.

(f) The New Motor Vehicle Board may adopt regulations to implement this section. The regulations shall include, at a minimum, a formula for calculating the fee, established pursuant to subdivision (b), for each motor vehicle and the total amount of fees to be collected from each manufacturer.

(g) Any revenues already received by the Arbitration Certification Program and deposited in the Vehicle Inspection and Repair Fund for the 1991–92 fiscal year that have not yet been spent shall be deposited into the Certification Account in the Consumer Affairs Fund.

Added Stats 1987 ch 1280 § 1, operative July 1, 1988, as B & P C § 9889.75. Amended Stats 1988 ch 203 § 1, effective June 23, 1988; Stats 1989 ch 193 § 1, ch 1154 § 2.5. Amended and Renumbered by Stats 1991 ch 689 § 8 (AB 211). Amended Stats 1992 ch 1289 § 4 (AB 2743); Stats 1998 ch 970 § 3 (AB 2802).

## DIVISION 1.2

### Joint Committee on Boards, Commissions, and Consumer Protection

#### CHAPTER 1

#### Review of Boards under the Department of Consumer Affairs

Section

473.1. [Section repealed 2011.]

473.3. [Section repealed 2011.]

**§ 473.1. [Section repealed 2011.]**

Added Stats 1994 ch 908 § 5 (SB 2036). Amended Stats 1997 ch 78 § 3.5 (AB 71); Stats 2000 ch 393 § 1 (SB 2028); Stats 2002 ch 825 § 2 (SB

1952); Stats 2003 ch 789 § 3 (SB 364); Stats 2009 ch 310 § 5 (AB 48), effective January 1, 2010. Repealed Stats 2010 ch 670 § 3 (AB 2130), effective January 1, 2011. The repealed section related to applicability of chapter “Review of Boards under the Department of Consumer Affairs.”

**§ 473.3. [Section repealed 2011.]**

Added Stats 1994 ch 908 § 5 (SB 2036). Amended Stats 1997 ch 78 § 3.7 (AB 71); Stats 2000 ch 393 § 5 (SB 2028); Stats 2001 ch 399 § 1 (AB 1720); Stats 2003 ch 789 § 5 (SB 364); Stats 2004 ch 33 § 6 (AB 1467), effective April 13, 2004. Repealed Stats 2010 ch 670 § 3 (AB 2130), effective January 1, 2011. The repealed section related to public hearings prior to termination, continuation, or reestablishment of any board, the review of the Bureau for Private Postsecondary and Vocational Education and Bureau of Automotive Repair.

**DIVISION 1.5**

**Denial, Suspension and Revocation of Licenses**

**CHAPTER 1**

**General Provisions**

Section

- 475. Applicability of division
- 476. Exemptions
- 477. "Board"; "License"
- 478. "Application"; "Material"

**§ 475. Applicability of division**

(a) Notwithstanding any other provisions of this code, the provisions of this division shall govern the denial of licenses on the grounds of:

(1) Knowingly making a false statement of material fact, or knowingly omitting to state a material fact, in an application for a license.

(2) Conviction of a crime.

(3) Commission of any act involving dishonesty, fraud or deceit with the intent to substantially benefit himself or another, or substantially injure another.

(4) Commission of any act which, if done by a licentiate of the business or profession in question, would be grounds for suspension or revocation of license.

(b) Notwithstanding any other provisions of this code, the provisions of this division shall govern the suspension and revocation of licenses on grounds specified in paragraphs (1) and (2) of subdivision (a).

(c) A license shall not be denied, suspended, or revoked on the grounds of a lack of good moral character or any similar ground relating to an applicant's character, reputation, personality, or habits.

Added Stats 1972 ch 903 § 1. Amended Stats 1974 ch 1321 § 1; Stats 1992 ch 1289 § 5 (AB 2743).

**§ 476. Exemptions**

(a) Except as provided in subdivision (b), nothing in this division shall apply to the licensure or registration of persons pursuant to Chapter 4 (commencing with Section 6000) of Division 3, or pursuant to Division 9 (commencing with Section 23000) or pursuant to Chapter 5 (commencing with Section 19800) of Division 8.

(b) Section 494.5 shall apply to the licensure of persons authorized to practice law pursuant to Chapter 4 (commencing with Section 6000) of Division 3, and the licensure or registration of persons pursuant to Chapter 5 (commencing with Section 19800) of Division 8 or pursuant to Division 9 (commencing with Section 23000).

Added Stats 1972 ch 903 § 1. Amended Stats 1983 ch 721 § 1; Stats 2011 ch 455 § 2 (AB 1424), effective January 1, 2012.

**§ 477. "Board"; "License"**

As used in this division:

(a) "Board" includes "bureau," "commission," "committee," "department," "division," "examining committee," "program," and "agency."

(b) "License" includes certificate, registration or other means to engage in a business or profession regulated by this code.

Added Stats 1972 ch 903 § 1. Amended Stats 1974 ch 1321 § 2; Stats 1983 ch 95 § 1; Stats 1991 ch 654 § 5 (AB 1893).

**§ 478. "Application"; "Material"**

(a) As used in this division, "application" includes the original documents or writings filed and any other supporting documents or writings including supporting documents provided or filed contemporaneously, or later, in support of the application whether provided or filed by the applicant or by any other person in support of the application.

(b) As used in this division, "material" includes a statement or omission substantially related to the qualifications, functions, or duties of the business or profession.

Added Stats 1992 ch 1289 § 6 (AB 2743).

**CHAPTER 2**

**Denial of Licenses**

Section

- 480. Grounds for denial; Effect of obtaining certificate of rehabilitation
- 481. Crime and job-fitness criteria
- 482. Rehabilitation criteria
- 483. [Section renumbered 1987.]
- 484. Attestation to good moral character of applicant
- 485. Procedure upon denial
- 486. Contents of decision or notice
- 487. Hearing; Time
- 488. Hearing request
- 489. Denial of application without a hearing

**§ 480. Grounds for denial; Effect of obtaining certificate of rehabilitation**

(a) A board may deny a license regulated by this code on the grounds that the applicant has one of the following:

(1) Been convicted of a crime. A conviction within the meaning of this section means a plea or verdict of guilty or a conviction following a plea of nolo contendere. Any action that a board is permitted to take following the establishment of a conviction may be taken when the time for appeal has elapsed, or the judgment of conviction has been affirmed on appeal, or when an order granting probation is made suspending the imposition of sentence, irrespective of a subsequent order under the provisions of Section 1203.4 of the Penal Code.

(2) Done any act involving dishonesty, fraud, or deceit with the intent to substantially benefit himself or herself or another, or substantially injure another.

(3)(A) Done any act that if done by a licentiate of the business or profession in question, would be grounds for suspension or revocation of license.

(B) The board may deny a license pursuant to this subdivision only if the crime or act is substantially related to the qualifications, functions, or duties of the business or profession for which application is made.

(b) Notwithstanding any other provision of this code, no person shall be denied a license solely on the basis that he or she has been convicted of a felony if he or she has obtained a certificate of rehabilitation under Chapter 3.5 (commencing with Section 4852.01) of Title 6 of Part 3 of the Penal Code or that he or she has been

convicted of a misdemeanor if he or she has met all applicable requirements of the criteria of rehabilitation developed by the board to evaluate the rehabilitation of a person when considering the denial of a license under subdivision (a) of Section 482.

(c) A board may deny a license regulated by this code on the ground that the applicant knowingly made a false statement of fact required to be revealed in the application for the license.

Added Stats 1974 ch 1321 § 4. Amended Stats 1976 ch 947 § 1; Stats 1979 ch 876 § 2; Stats 2008 ch 179 § 2 (SB 1498), effective January 1, 2009.

#### § 481. Crime and job-fitness criteria

Each board under the provisions of this code shall develop criteria to aid it, when considering the denial, suspension or revocation of a license, to determine whether a crime or act is substantially related to the qualifications, functions, or duties of the business or profession it regulates.

Added Stats 1974 ch 1321 § 6.

#### § 482. Rehabilitation criteria

Each board under the provisions of this code shall develop criteria to evaluate the rehabilitation of a person when:

(a) Considering the denial of a license by the board under Section 480; or

(b) Considering suspension or revocation of a license under Section 490.

Each board shall take into account all competent evidence of rehabilitation furnished by the applicant or licensee.

Added Stats 1972 ch 903 § 1. Amended Stats 1974 ch 1321 § 7.

#### § 483. [Section renumbered 1987.]

Added Stats 1986 ch 1205 § 1. Amended and Renumbered B & P C § 154.5 by Stats 1987 ch 850 § 8.

#### § 484. Attestation to good moral character of applicant

No person applying for licensure under this code shall be required to submit to any licensing board any attestation by other persons to his good moral character.

Added Stats 1972 ch 903 § 1. Amended Stats 1974 ch 1321 § 9.

#### § 485. Procedure upon denial

Upon denial of an application for a license under this chapter or Section 496, the board shall do either of the following:

(a) File and serve a statement of issues in accordance with Chapter 5 (commencing with Section 11500) of Part 1 of Division 3 of Title 2 of the Government Code.

(b) Notify the applicant that the application is denied, stating (1) the reason for the denial, and (2) that the applicant has the right to a hearing under Chapter 5 (commencing with Section 11500) of Part 1 of Division 3 of Title 2 of the Government Code if written request for hearing is made within 60 days after service of the notice of denial. Unless written request for hearing is made within the 60-day period, the applicant's right to a hearing is deemed waived.

Service of the notice of denial may be made in the manner authorized for service of summons in civil ac-

tions, or by registered mail addressed to the applicant at the latest address filed by the applicant in writing with the board in his or her application or otherwise. Service by mail is complete on the date of mailing.

Added Stats 1972 ch 903 § 1. Amended Stats 1997 ch 758 § 2.3 (SB 1346).

#### § 486. Contents of decision or notice

Where the board has denied an application for a license under this chapter or Section 496, it shall, in its decision, or in its notice under subdivision (b) of Section 485, inform the applicant of the following:

(a) The earliest date on which the applicant may reapply for a license which shall be one year from the effective date of the decision, or service of the notice under subdivision (b) of Section 485, unless the board prescribes an earlier date or a later date is prescribed by another statute.

(b) That all competent evidence of rehabilitation presented will be considered upon a reapplication.

Along with the decision, or the notice under subdivision (b) of Section 485, the board shall serve a copy of the criteria relating to rehabilitation formulated under Section 482.

Added Stats 1972 ch 903 § 1. Amended Stats 1974 ch 1321 § 9.5; Stats 1997 ch 758 § 2.4 (SB 1346).

#### § 487. Hearing; Time

If a hearing is requested by the applicant, the board shall conduct such hearing within 90 days from the date the hearing is requested unless the applicant shall request or agree in writing to a postponement or continuance of the hearing. Notwithstanding the above, the Office of Administrative Hearings may order, or on a showing of good cause, grant a request for, up to 45 additional days within which to conduct a hearing, except in cases involving alleged examination or licensing fraud, in which cases the period may be up to 180 days. In no case shall more than two such orders be made or requests be granted.

Added Stats 1972 ch 903 § 1. Amended Stats 1974 ch 1321 § 10; Stats 1986 ch 220 § 1, effective June 30, 1986.

#### § 488. Hearing request

Except as otherwise provided by law, following a hearing requested by an applicant pursuant to subdivision (b) of Section 485, the board may take any of the following actions:

(a) Grant the license effective upon completion of all licensing requirements by the applicant.

(b) Grant the license effective upon completion of all licensing requirements by the applicant, immediately revoke the license, stay the revocation, and impose probationary conditions on the license, which may include suspension.

(c) Deny the license.

(d) Take other action in relation to denying or granting the license as the board in its discretion may deem proper.

Added Stats 2000 ch 568 § 2 (AB 2888).

#### § 489. Denial of application without a hearing

Any agency in the department which is authorized by law to deny an application for a license upon the grounds

specified in Section 480 or 496, may without a hearing deny an application upon any of those grounds, if within one year previously, and after proceedings conducted in accordance with Chapter 5 (commencing with Section 11500) of Part 1 of Division 3 of Title 2 of the Government Code, that agency has denied an application from the same applicant upon the same ground.

Added Stats 1955 ch 1151 § 1, as B & P C § 116. Amended Stats 1978 ch 1161 § 2. Renumbered by Stats 1989 ch 1104 § 1. Amended Stats 1997 ch 758 § 2.5 (SB 1346).

**CHAPTER 3**

**Suspension and Revocation of Licenses**

Section

- 490. Grounds for suspension or revocation; Discipline for substantially related crimes; Conviction; Legislative findings
- 490.5. Suspension of license for failure to comply with child support order
- 491. Procedure upon suspension or revocation
- 492. Effect of completion of drug diversion program on disciplinary action or denial of license
- 493. Evidentiary effect of record of conviction of crime substantially related to licensee's qualifications, functions, and duties
- 494. Interim suspension or restriction order
- 494.5. Agency actions when licensee is on certified list; Definitions; Collection and distribution of certified list information; Timing; Notices; Challenges by applicants and licensees; Release forms; Interagency agreements; Fees; Remedies; Inquiries and disclosure of information; Severability

**§ 490. Grounds for suspension or revocation; Discipline for substantially related crimes; Conviction; Legislative findings**

(a) In addition to any other action that a board is permitted to take against a licensee, a board may suspend or revoke a license on the ground that the licensee has been convicted of a crime, if the crime is substantially related to the qualifications, functions, or duties of the business or profession for which the license was issued.

(b) Notwithstanding any other provision of law, a board may exercise any authority to discipline a licensee for conviction of a crime that is independent of the authority granted under subdivision (a) only if the crime is substantially related to the qualifications, functions, or duties of the business or profession for which the licensee's license was issued.

(c) A conviction within the meaning of this section means a plea or verdict of guilty or a conviction following a plea of nolo contendere. An action that a board is permitted to take following the establishment of a conviction may be taken when the time for appeal has elapsed, or the judgment of conviction has been affirmed on appeal, or when an order granting probation is made suspending the imposition of sentence, irrespective of a subsequent order under Section 1203.4 of the Penal Code.

(d) The Legislature hereby finds and declares that the application of this section has been made unclear by the holding in *Petropoulos v. Department of Real Estate* (2006) 142 Cal.App.4th 554, and that the holding in that case has placed a significant number of statutes and regulations in question, resulting in potential harm to the consumers of California from licensees who have

been convicted of crimes. Therefore, the Legislature finds and declares that this section establishes an independent basis for a board to impose discipline upon a licensee, and that the amendments to this section made by Chapter 33 of the Statutes of 2008 do not constitute a change to, but rather are declaratory of, existing law.

Added Stats 1974 ch 1321 § 13. Amended Stats 1979 ch 876 § 3; Stats 1980 ch 548 § 1; Stats 1992 ch 1289 § 7 (AB 2743); Stats 2008 ch 33 § 2 (SB 797) (ch 33 prevails), effective June 23, 2008, ch 179 § 3 (SB 1498), effective January 1, 2009; Stats 2010 ch 328 § 2 (SB 1330), effective January 1, 2011.

**§ 490.5. Suspension of license for failure to comply with child support order**

A board may suspend a license pursuant to Section 17520 of the Family Code if a licensee is not in compliance with a child support order or judgment.

Added Stats 1994 ch 906 § 1 (AB 923), operative January 1, 1996. Amended Stats 2010 ch 328 § 3 (SB 1330), effective January 1, 2011.

**§ 491. Procedure upon suspension or revocation**

Upon suspension or revocation of a license by a board on one or more of the grounds specified in Section 490, the board shall:

(a) Send a copy of the provisions of Section 11522 of the Government Code to the ex-licensee.

(b) Send a copy of the criteria relating to rehabilitation formulated under Section 482 to the ex-licensee.

Added Stats 1972 ch 903 § 1. Amended Stats 1974 ch 1321 § 14; Stats 1975 ch 678 § 1.

**§ 492. Effect of completion of drug diversion program on disciplinary action or denial of license**

Notwithstanding any other provision of law, successful completion of any diversion program under the Penal Code, or successful completion of an alcohol and drug problem assessment program under Article 5 (commencing with Section 23249.50) of Chapter 12 of Division 11 of the Vehicle Code, shall not prohibit any agency established under Division 2 (commencing with Section 500) of this code, or any initiative act referred to in that division, from taking disciplinary action against a licensee or from denying a license for professional misconduct, notwithstanding that evidence of that misconduct may be recorded in a record pertaining to an arrest.

This section shall not be construed to apply to any drug diversion program operated by any agency established under Division 2 (commencing with Section 500) of this code, or any initiative act referred to in that division.

Added Stats 1987 ch 1183 § 1. Amended Stats 1994 ch 26 § 15 (AB 1807), effective March 30, 1994.

**§ 493. Evidentiary effect of record of conviction of crime substantially related to licensee's qualifications, functions, and duties**

Notwithstanding any other provision of law, in a proceeding conducted by a board within the department pursuant to law to deny an application for a license or to suspend or revoke a license or otherwise take disciplinary action against a person who holds a license, upon the ground that the applicant or the licensee has been convicted of a crime substantially related to the qualifications, functions, and duties of the licensee in question, the record of conviction of the crime shall be conclusive

evidence of the fact that the conviction occurred, but only of that fact, and the board may inquire into the circumstances surrounding the commission of the crime in order to fix the degree of discipline or to determine if the conviction is substantially related to the qualifications, functions, and duties of the licensee in question.

As used in this section, "license" includes "certificate," "permit," "authority," and "registration."

Added Stats 1961 ch 934 § 1, as B & P C § 117. Amended Stats 1978 ch 1161 § 3. Renumbered by Stats 1989 ch 1104 § 1.3.

#### § 494. Interim suspension or restriction order

(a) A board or an administrative law judge sitting alone, as provided in subdivision (h), may, upon petition, issue an interim order suspending any licentiate or imposing license restrictions, including, but not limited to, mandatory biological fluid testing, supervision, or remedial training. The petition shall include affidavits that demonstrate, to the satisfaction of the board, both of the following:

(1) The licentiate has engaged in acts or omissions constituting a violation of this code or has been convicted of a crime substantially related to the licensed activity.

(2) Permitting the licentiate to continue to engage in the licensed activity, or permitting the licentiate to continue in the licensed activity without restrictions, would endanger the public health, safety, or welfare.

(b) No interim order provided for in this section shall be issued without notice to the licentiate unless it appears from the petition and supporting documents that serious injury would result to the public before the matter could be heard on notice.

(c) Except as provided in subdivision (b), the licentiate shall be given at least 15 days' notice of the hearing on the petition for an interim order. The notice shall include documents submitted to the board in support of the petition. If the order was initially issued without notice as provided in subdivision (b), the licentiate shall be entitled to a hearing on the petition within 20 days of the issuance of the interim order without notice. The licentiate shall be given notice of the hearing within two days after issuance of the initial interim order, and shall receive all documents in support of the petition. The failure of the board to provide a hearing within 20 days following the issuance of the interim order without notice, unless the licentiate waives his or her right to the hearing, shall result in the dissolution of the interim order by operation of law.

(d) At the hearing on the petition for an interim order, the licentiate may:

(1) Be represented by counsel.

(2) Have a record made of the proceedings, copies of which shall be available to the licentiate upon payment of costs computed in accordance with the provisions for transcript costs for judicial review contained in Section 11523 of the Government Code.

(3) Present affidavits and other documentary evidence.

(4) Present oral argument.

(e) The board, or an administrative law judge sitting alone as provided in subdivision (h), shall issue a decision on the petition for interim order within five business days following submission of the matter. The standard of proof required to obtain an interim order pursuant to

this section shall be a preponderance of the evidence standard. If the interim order was previously issued without notice, the board shall determine whether the order shall remain in effect, be dissolved, or modified.

(f) The board shall file an accusation within 15 days of the issuance of an interim order. In the case of an interim order issued without notice, the time shall run from the date of the order issued after the noticed hearing. If the licentiate files a Notice of Defense, the hearing shall be held within 30 days of the agency's receipt of the Notice of Defense. A decision shall be rendered on the accusation no later than 30 days after submission of the matter. Failure to comply with any of the requirements in this subdivision shall dissolve the interim order by operation of law.

(g) Interim orders shall be subject to judicial review pursuant to Section 1094.5 of the Code of Civil Procedure and shall be heard only in the superior court in and for the Counties of Sacramento, San Francisco, Los Angeles, or San Diego. The review of an interim order shall be limited to a determination of whether the board abused its discretion in the issuance of the interim order. Abuse of discretion is established if the respondent board has not proceeded in the manner required by law, or if the court determines that the interim order is not supported by substantial evidence in light of the whole record.

(h) The board may, in its sole discretion, delegate the hearing on any petition for an interim order to an administrative law judge in the Office of Administrative Hearings. If the board hears the noticed petition itself, an administrative law judge shall preside at the hearing, rule on the admission and exclusion of evidence, and advise the board on matters of law. The board shall exercise all other powers relating to the conduct of the hearing but may delegate any or all of them to the administrative law judge. When the petition has been delegated to an administrative law judge, he or she shall sit alone and exercise all of the powers of the board relating to the conduct of the hearing. A decision issued by an administrative law judge sitting alone shall be final when it is filed with the board. If the administrative law judge issues an interim order without notice, he or she shall preside at the noticed hearing, unless unavailable, in which case another administrative law judge may hear the matter. The decision of the administrative law judge sitting alone on the petition for an interim order is final, subject only to judicial review in accordance with subdivision (g).

(i) Failure to comply with an interim order issued pursuant to subdivision (a) or (b) shall constitute a separate cause for disciplinary action against any licentiate, and may be heard at, and as a part of, the noticed hearing provided for in subdivision (f). Allegations of noncompliance with the interim order may be filed at any time prior to the rendering of a decision on the accusation. Violation of the interim order is established upon proof that the licentiate was on notice of the interim order and its terms, and that the order was in effect at the time of the violation. The finding of a violation of an interim order made at the hearing on the accusation shall be reviewed as a part of any review of a final decision of the agency.

If the interim order issued by the agency provides for anything less than a complete suspension of the licenti-

ate from his or her business or profession, and the licentiate violates the interim order prior to the hearing on the accusation provided for in subdivision (f), the agency may, upon notice to the licentiate and proof of violation, modify or expand the interim order.

(j) A plea or verdict of guilty or a conviction after a plea of nolo contendere is deemed to be a conviction within the meaning of this section. A certified record of the conviction shall be conclusive evidence of the fact that the conviction occurred. A board may take action under this section notwithstanding the fact that an appeal of the conviction may be taken.

(k) The interim orders provided for by this section shall be in addition to, and not a limitation on, the authority to seek injunctive relief provided in any other provision of law.

(l) In the case of a board, a petition for an interim order may be filed by the executive officer. In the case of a bureau or program, a petition may be filed by the chief or program administrator, as the case may be.

(m) "Board," as used in this section, shall include any agency described in Section 22, and any allied health agency within the jurisdiction of the Medical Board of California. Board shall also include the Osteopathic Medical Board of California and the State Board of Chiropractic Examiners. The provisions of this section shall not be applicable to the Medical Board of California, the Board of Podiatric Medicine, or the State Athletic Commission.

Added Stats 1993 ch 840 § 1 (SB 842). Amended Stats 1994 ch 1275 § 4 (SB 2101).

**§ 494.5. Agency actions when licensee is on certified list; Definitions; Collection and distribution of certified list information; Timing; Notices; Challenges by applicants and licensees; Release forms; Interagency agreements; Fees; Remedies; Inquiries and disclosure of information; Severability**

(a)(1) Except as provided in paragraphs (2), (3), and (4), a state governmental licensing entity shall refuse to issue, reactivate, reinstate, or renew a license and shall suspend a license if a licensee's name is included on a certified list.

(2) The Department of Motor Vehicles shall suspend a license if a licensee's name is included on a certified list. Any reference in this section to the issuance, reactivation, reinstatement, renewal, or denial of a license shall not apply to the Department of Motor Vehicles.

(3) The State Bar of California may recommend to refuse to issue, reactivate, reinstate, or renew a license and may recommend to suspend a license if a licensee's name is included on a certified list. The word "may" shall be substituted for the word "shall" relating to the issuance of a temporary license, refusal to issue, reactivate, reinstate, renew, or suspend a license in this section for licenses under the jurisdiction of the California Supreme Court.

(4) The Department of Alcoholic Beverage Control may refuse to issue, reactivate, reinstate, or renew a license, and may suspend a license, if a licensee's name is included on a certified list.

(b) For purposes of this section:

(1) "Certified list" means either the list provided by the State Board of Equalization or the list provided by the Franchise Tax Board of persons whose names appear on the lists of the 500 largest tax delinquencies pursuant to Section 7063 or 19195 of the Revenue and Taxation Code, as applicable.

(2) "License" includes a certificate, registration, or any other authorization to engage in a profession or occupation issued by a state governmental licensing entity. "License" includes a driver's license issued pursuant to Chapter 1 (commencing with Section 12500) of Division 6 of the Vehicle Code. "License" excludes a vehicle registration issued pursuant to Division 3 (commencing with Section 4000) of the Vehicle Code.

(3) "Licensee" means an individual authorized by a license to drive a motor vehicle or authorized by a license, certificate, registration, or other authorization to engage in a profession or occupation issued by a state governmental licensing entity.

(4) "State governmental licensing entity" means any entity listed in Section 101, 1000, or 19420, the office of the Attorney General, the Department of Insurance, the Department of Motor Vehicles, the State Bar of California, the Department of Real Estate, and any other state agency, board, or commission that issues a license, certificate, or registration authorizing an individual to engage in a profession or occupation, including any certificate, business or occupational license, or permit or license issued by the Department of Motor Vehicles or the Department of the California Highway Patrol. "State governmental licensing entity" shall not include the Contractors' State License Board.

(c) The State Board of Equalization and the Franchise Tax Board shall each submit its respective certified list to every state governmental licensing entity. The certified lists shall include the name, social security number or taxpayer identification number, and the last known address of the persons identified on the certified lists.

(d) Notwithstanding any other law, each state governmental licensing entity shall collect the social security number or the federal taxpayer identification number from all applicants for the purposes of matching the names of the certified lists provided by the State Board of Equalization and the Franchise Tax Board to applicants and licensees.

(e)(1) Each state governmental licensing entity shall determine whether an applicant or licensee is on the most recent certified list provided by the State Board of Equalization and the Franchise Tax Board.

(2) If an applicant or licensee is on either of the certified lists, the state governmental licensing entity shall immediately provide a preliminary notice to the applicant or licensee of the entity's intent to suspend or withhold issuance or renewal of the license. The preliminary notice shall be delivered personally or by mail to the applicant's or licensee's last known mailing address on file with the state governmental licensing entity within 30 days of receipt of the certified list. Service by mail shall be completed in accordance with Section 1013 of the Code of Civil Procedure.

(A) The state governmental licensing entity shall issue a temporary license valid for a period of 90 days to any applicant whose name is on a certified list if the applicant is otherwise eligible for a license.



(B) The 90-day time period for a temporary license shall not be extended. Only one temporary license shall be issued during a regular license term and the term of the temporary license shall coincide with the first 90 days of the regular license term. A license for the full term or the remainder of the license term may be issued or renewed only upon compliance with this section.

(C) In the event that a license is suspended or an application for a license or the renewal of a license is denied pursuant to this section, any funds paid by the applicant or licensee shall not be refunded by the state governmental licensing entity.

(f)(1) A state governmental licensing entity shall refuse to issue or shall suspend a license pursuant to this section no sooner than 90 days and no later than 120 days of the mailing of the preliminary notice described in paragraph (2) of subdivision (e), unless the state governmental licensing entity has received a release pursuant to subdivision (h). The procedures in the administrative adjudication provisions of the Administrative Procedure Act (Chapter 4.5 (commencing with Section 11400) and Chapter 5 (commencing with Section 11500) of Part 1 of Division 3 of Title 2 of the Government Code) shall not apply to the denial or suspension of, or refusal to renew, a license or the issuance of a temporary license pursuant to this section.

(2) Notwithstanding any other law, if a board, bureau, or commission listed in Section 101, other than the Contractors' State License Board, fails to take action in accordance with this section, the Department of Consumer Affairs shall issue a temporary license or suspend or refuse to issue, reactivate, reinstate, or renew a license, as appropriate.

(g) Notices shall be developed by each state governmental licensing entity. For an applicant or licensee on the State Board of Equalization's certified list, the notice shall include the address and telephone number of the State Board of Equalization, and shall emphasize the necessity of obtaining a release from the State Board of Equalization as a condition for the issuance, renewal, or continued valid status of a license or licenses. For an applicant or licensee on the Franchise Tax Board's certified list, the notice shall include the address and telephone number of the Franchise Tax Board, and shall emphasize the necessity of obtaining a release from the Franchise Tax Board as a condition for the issuance, renewal, or continued valid status of a license or licenses.

(1) The notice shall inform the applicant that the state governmental licensing entity shall issue a temporary license, as provided in subparagraph (A) of paragraph (2) of subdivision (e), for 90 calendar days if the applicant is otherwise eligible and that upon expiration of that time period, the license will be denied unless the state governmental licensing entity has received a release from the State Board of Equalization or the Franchise Tax Board, whichever is applicable.

(2) The notice shall inform the licensee that any license suspended under this section will remain suspended until the state governmental licensing entity receives a release along with applications and fees, if applicable, to reinstate the license.

(3) The notice shall also inform the applicant or licensee that if an application is denied or a license is suspended pursuant to this section, any moneys paid by

the applicant or licensee shall not be refunded by the state governmental licensing entity. The state governmental licensing entity shall also develop a form that the applicant or licensee shall use to request a release by the State Board of Equalization or the Franchise Tax Board. A copy of this form shall be included with every notice sent pursuant to this subdivision.

(h) If the applicant or licensee wishes to challenge the submission of his or her name on a certified list, the applicant or licensee shall make a timely written request for release to the State Board of Equalization or the Franchise Tax Board, whichever is applicable. The State Board of Equalization or the Franchise Tax Board shall immediately send a release to the appropriate state governmental licensing entity and the applicant or licensee, if any of the following conditions are met:

(1) The applicant or licensee has complied with the tax obligation, either by payment of the unpaid taxes or entry into an installment payment agreement, as described in Section 6832 or 19008 of the Revenue and Taxation Code, to satisfy the unpaid taxes.

(2) The applicant or licensee has submitted a request for release not later than 45 days after the applicant's or licensee's receipt of a preliminary notice described in paragraph (2) of subdivision (e), but the State Board of Equalization or the Franchise Tax Board, whichever is applicable, will be unable to complete the release review and send notice of its findings to the applicant or licensee and state governmental licensing entity within 45 days after the State Board of Equalization's or the Franchise Tax Board's receipt of the applicant's or licensee's request for release. Whenever a release is granted under this paragraph, and, notwithstanding that release, the applicable license or licenses have been suspended erroneously, the state governmental licensing entity shall reinstate the applicable licenses with retroactive effect back to the date of the erroneous suspension and that suspension shall not be reflected on any license record.

(3) The applicant or licensee is unable to pay the outstanding tax obligation due to a current financial hardship. "Financial hardship" means financial hardship as determined by the State Board of Equalization or the Franchise Tax Board, whichever is applicable, where the applicant or licensee is unable to pay any part of the outstanding liability and the applicant or licensee is unable to qualify for an installment payment arrangement as provided for by Section 6832 or Section 19008 of the Revenue and Taxation Code. In order to establish the existence of a financial hardship, the applicant or licensee shall submit any information, including information related to reasonable business and personal expenses, requested by the State Board of Equalization or the Franchise Tax Board, whichever is applicable, for purposes of making that determination.

(i) An applicant or licensee is required to act with diligence in responding to notices from the state governmental licensing entity and the State Board of Equalization or the Franchise Tax Board with the recognition that the temporary license will lapse or the license suspension will go into effect after 90 days and that the State Board of Equalization or the Franchise Tax Board must have time to act within that period. An applicant's or licensee's delay in acting, without good cause, which directly results in the inability of the State Board of

Equalization or the Franchise Tax Board, whichever is applicable, to complete a review of the applicant's or licensee's request for release shall not constitute the diligence required under this section which would justify the issuance of a release. An applicant or licensee shall have the burden of establishing that he or she diligently responded to notices from the state governmental licensing entity or the State Board of Equalization or the Franchise Tax Board and that any delay was not without good cause.

(j) The State Board of Equalization or the Franchise Tax Board shall create release forms for use pursuant to this section. When the applicant or licensee has complied with the tax obligation by payment of the unpaid taxes, or entry into an installment payment agreement, or establishing the existence of a current financial hardship as defined in paragraph (3) of subdivision (h), the State Board of Equalization or the Franchise Tax Board, whichever is applicable, shall mail a release form to the applicant or licensee and provide a release to the appropriate state governmental licensing entity. Any state governmental licensing entity that has received a release from the State Board of Equalization and the Franchise Tax Board pursuant to this subdivision shall process the release within five business days of its receipt. If the State Board of Equalization or the Franchise Tax Board determines subsequent to the issuance of a release that the licensee has not complied with their installment payment agreement, the State Board of Equalization or the Franchise Tax Board, whichever is applicable, shall notify the state governmental licensing entity and the licensee in a format prescribed by the State Board of Equalization or the Franchise Tax Board, whichever is applicable, that the licensee is not in compliance and the release shall be rescinded. The State Board of Equalization and the Franchise Tax Board may, when it is economically feasible for the state governmental licensing entity to develop an automated process for complying with this subdivision, notify the state governmental licensing entity in a manner prescribed by the State Board of Equalization or the Franchise Tax Board, whichever is applicable, that the licensee has not complied with the installment payment agreement. Upon receipt of this notice, the state governmental licensing entity shall immediately notify the licensee on a form prescribed by the state governmental licensing entity that the licensee's license will be suspended on a specific date, and this date shall be no longer than 30 days from the date the form is mailed. The licensee shall be further notified that the license will remain suspended until a new release is issued in accordance with this subdivision.

(k) The State Board of Equalization and the Franchise Tax Board may enter into interagency agreements with the state governmental licensing entities necessary to implement this section.

(l) Notwithstanding any other law, a state governmental licensing entity, with the approval of the appropriate department director or governing body, may impose a fee on a licensee whose license has been suspended pursuant to this section. The fee shall not exceed the amount necessary for the state governmental licensing entity to cover its costs in carrying out the provisions of this section. Fees imposed pursuant to this

section shall be deposited in the fund in which other fees imposed by the state governmental licensing entity are deposited and shall be available to that entity upon appropriation in the annual Budget Act.

(m) The process described in subdivision (h) shall constitute the sole administrative remedy for contesting the issuance of a temporary license or the denial or suspension of a license under this section.

(n) Any state governmental licensing entity receiving an inquiry as to the licensed status of an applicant or licensee who has had a license denied or suspended under this section or who has been granted a temporary license under this section shall respond that the license was denied or suspended or the temporary license was issued only because the licensee appeared on a list of the 500 largest tax delinquencies pursuant to Section 7063 or 19195 of the Revenue and Taxation Code. Information collected pursuant to this section by any state agency, board, or department shall be subject to the Information Practices Act of 1977 (Chapter 1 (commencing with Section 1798) of Title 1.8 of Part 4 of Division 3 of the Civil Code). Any state governmental licensing entity that discloses on its Internet Web site or other publication that the licensee has had a license denied or suspended under this section or has been granted a temporary license under this section shall prominently disclose, in bold and adjacent to the information regarding the status of the license, that the only reason the license was denied, suspended, or temporarily issued is because the licensee failed to pay taxes.

(o) Any rules and regulations issued pursuant to this section by any state agency, board, or department may be adopted as emergency regulations in accordance with the rulemaking provisions of the Administrative Procedure Act (Chapter 3.5 (commencing with Section 11340) of Part 1 of Division 3 of Title 2 of the Government Code). The adoption of these regulations shall be deemed an emergency and necessary for the immediate preservation of the public peace, health, and safety, or general welfare. The regulations shall become effective immediately upon filing with the Secretary of State.

(p) The State Board of Equalization, the Franchise Tax Board, and state governmental licensing entities, as appropriate, shall adopt regulations as necessary to implement this section.

(q)(1) Neither the state governmental licensing entity, nor any officer, employee, or agent, or former officer, employee, or agent of a state governmental licensing entity, may disclose or use any information obtained from the State Board of Equalization or the Franchise Tax Board, pursuant to this section, except to inform the public of the denial, refusal to renew, or suspension of a license or the issuance of a temporary license pursuant to this section. The release or other use of information received by a state governmental licensing entity pursuant to this section, except as authorized by this section, is punishable as a misdemeanor. This subdivision may not be interpreted to prevent the State Bar of California from filing a request with the Supreme Court of California to suspend a member of the bar pursuant to this section.

(2) A suspension of, or refusal to renew, a license or issuance of a temporary license pursuant to this section does not constitute denial or discipline of a licensee for

purposes of any reporting requirements to the National Practitioner Data Bank and shall not be reported to the National Practitioner Data Bank or the Healthcare Integrity and Protection Data Bank.

(3) Upon release from the certified list, the suspension or revocation of the applicant's or licensee's license shall be purged from the state governmental licensing entity's Internet Web site or other publication within three business days. This paragraph shall not apply to the State Bar of California.

(r) If any provision of this section or the application thereof to any person or circumstance is held invalid, that invalidity shall not affect other provisions or applications of this section that can be given effect without the invalid provision or application, and to this end the provisions of this section are severable.

(s) All rights to review afforded by this section to an applicant shall also be afforded to a licensee.

(t) Unless otherwise provided in this section, the policies, practices, and procedures of a state governmental licensing entity with respect to license suspensions under this section shall be the same as those applicable with respect to suspensions pursuant to Section 17520 of the Family Code.

(u) No provision of this section shall be interpreted to allow a court to review and prevent the collection of taxes prior to the payment of those taxes in violation of the California Constitution.

(v) This section shall apply to any licensee whose name appears on a list of the 500 largest tax delinquencies pursuant to Section 7063 or 19195 of the Revenue and Taxation Code on or after July 1, 2012.

Added Stats 2011 ch 455 § 3 (AB 1424), effective January 1, 2012. Amended Stats 2012 ch 327 § 1 (SB 937), effective January 1, 2013.

## CHAPTER 4

### Public Reprovals

#### Section

495. Public reapproval of licentiate or certificate holder for act constituting grounds for suspension or revocation of license or certificate; Proceedings

#### § 495. Public reapproval of licentiate or certificate holder for act constituting grounds for suspension or revocation of license or certificate; Proceedings

Notwithstanding any other provision of law, any entity authorized to issue a license or certificate pursu-

ant to this code may publicly reprove a licentiate or certificate holder thereof, for any act that would constitute grounds to suspend or revoke a license or certificate. Any proceedings for public reapproval, public reproof and suspension, or public reproof and revocation shall be conducted in accordance with Chapter 5 (commencing with Section 11500) of Part 1 of Division 3 of Title 2 of the Government Code, or, in the case of a licensee or certificate holder under the jurisdiction of the State Department of Health Services, in accordance with Section 100171 of the Health and Safety Code.

Added Stats 1977 ch 886 § 1. Amended Stats 1997 ch 220 § 2 (SB 68), effective August 4, 1997.

## CHAPTER 5

### Examination Security

#### Section

496. Grounds for denial, suspension, or revocation of license  
498. Fraud, deceit or misrepresentation as grounds for action against license  
499. Action against license based on licentiate's actions regarding application of another

#### § 496. Grounds for denial, suspension, or revocation of license

A board may deny, suspend, revoke, or otherwise restrict a license on the ground that an applicant or licensee has violated Section 123 pertaining to subversion of licensing examinations.

Added Stats 1989 ch 1022 § 3.

#### § 498. Fraud, deceit or misrepresentation as grounds for action against license

A board may revoke, suspend, or otherwise restrict a license on the ground that the licensee secured the license by fraud, deceit, or knowing misrepresentation of a material fact or by knowingly omitting to state a material fact.

Added Stats 1992 ch 1289 § 8 (AB 2743).

#### § 499. Action against license based on licentiate's actions regarding application of another

A board may revoke, suspend, or otherwise restrict a license on the ground that the licensee, in support of another person's application for license, knowingly made a false statement of a material fact or knowingly omitted to state a material fact to the board regarding the application.

Added Stats 1992 ch 1289 § 9 (AB 2743).

**DIVISION 3**

**Professions and Vocations Generally**

**CHAPTER 20**

**Electronic and Appliance Repair Dealers**

**ARTICLE 1**

**General Provisions**

Section

9806. Installation by automobile dealer or manufacturer

9807. Service dealers may install, calibrate, service, maintain, and monitor ignition interlock devices

**§ 9806. Installation by automobile dealer or manufacturer**

(a) An automobile dealer or manufacturer, licensed pursuant to Chapter 4 (commencing with Section 11700) of Division 5 of the Vehicle Code shall not be required to be registered under this chapter where such dealer or manufacturer installs or replaces an electronic set or automobile burglar alarm as a function related to the sale or repair of a motor vehicle.

(b) No person registered pursuant to Chapter 20.3 (commencing with Section 9880) shall be required to register under this chapter where that person's activities are within the scope of his or her registration and consist of installing an electronic set or automobile burglar alarm system for use in private motor vehicles.

Added Stats 1982 ch 538 § 2. Amended Stats 1986 ch 207 § 2; Stats 1988 ch 480 § 1; Stats 1993 ch 1264 § 34 (SB 574).

**§ 9807. Service dealers may install, calibrate, service, maintain, and monitor ignition interlock devices**

(a) Notwithstanding any other law, a service dealer licensed under this chapter and authorized to engage in the electronic repair industry, as defined in subdivision (p) of Section 9801, may install, calibrate, service, maintain, and monitor ignition interlock devices.

(b) The bureau shall adopt regulations to implement this section consistent with the standards adopted by the Bureau of Automotive Repair and the Office of Traffic Safety under Section 9882.14.

Added Stats 2012 ch 661 § 15 (SB 1576), effective January 1, 2013. Amended Stats 2013 ch 319 § 14 (SB 822), effective January 1, 2014.

**CHAPTER 20.3**

**Automotive Repair**

**ARTICLE 1**

**General Provisions**

Section

9880. Chapter's scope and citation

9880.1. Definitions

9880.2. Exemptions from registration

9880.3. Priority of bureau; Protection of the public

**§ 9880. Chapter's scope and citation**

This chapter constitutes the chapter on automotive repair dealers. It may be cited as the Automotive Repair Act.

Added Stats 1971 ch 1578 § 1.5.

**§ 9880.1. Definitions**

The following definitions apply for the purposes of this chapter:

(a) "Automotive repair dealer" means a person who, for compensation, engages in the business of repairing or diagnosing malfunctions of motor vehicles.

(b) "Chief" means the Chief of the Bureau of Automotive Repair.

(c) "Bureau" means the Bureau of Automotive Repair.

(d) "Motor vehicle" means a passenger vehicle required to be registered with the Department of Motor Vehicles and all motorcycles whether or not required to be registered by the Department of Motor Vehicles.

(e) "Repair of motor vehicles" means all maintenance of and repairs to motor vehicles performed by an automotive repair dealer including automotive body repair work, but excluding those repairs made pursuant to a commercial business agreement and also excluding repairing tires, changing tires, lubricating vehicles, installing light bulbs, batteries, windshield wiper blades and other minor accessories, cleaning, adjusting, and replacing spark plugs, replacing fan belts, oil, and air filters, and other minor services, which the director, by regulation, determines are customarily performed by gasoline service stations.

No service shall be designated as minor, for purposes of this section, if the director finds that performance of the service requires mechanical expertise, has given rise to a high incidence of fraud or deceptive practices, or involves a part of the vehicle essential to its safe operation.

(f) "Person" includes firm, partnership, association, limited liability company, or corporation.

(g) An "automotive technician" is an employee of an automotive repair dealer or is that dealer, if the employer or dealer repairs motor vehicles and who for salary or wage performs maintenance, diagnostics, repair, removal, or installation of any integral component parts of an engine, driveline, chassis or body of any vehicle, but excluding repairing tires, changing tires, lubricating vehicles, installing light bulbs, batteries, windshield wiper blades, and other minor accessories; cleaning, replacing fan belts, oil and air filters; and other minor services which the director, by regulation, determines are customarily performed by a gasoline service station.

(h) "Director" means the Director of Consumer Affairs.

(i) "Commercial business agreement" means an agreement, whether in writing or oral, entered into between a business or commercial enterprise and an automotive repair dealer, prior to the repair which is requested being made, which agreement contemplates a continuing busi-

ness arrangement under which the automobile repair dealer is to repair any vehicle covered by the agreement, but does not mean any warranty or extended service agreement normally given by an automobile repair facility to its customers.

(j) “Customer” means the person presenting a motor vehicle for repair and authorizing the repairs to that motor vehicle. “Customer” shall not mean the automotive repair dealer providing the repair services or an insurer involved in a claim that includes the motor vehicle being repaired or an employee or agent or a person acting on behalf of the dealer or insurer.

Added Stats 1971 ch 1578 § 1.5. Amended Stats 1985 ch 610 § 1; Stats 1991 ch 386 § 1 (SB 290), ch 387 § 1.5 (AB 438); Stats 1993 ch 1264 § 48 (SB 574); Stats 1994 ch 1010 § 16 (SB 2053); Stats 1998 ch 879 § 23 (SB 2238); Stats 2004 ch 874 § 1 (AB 1079).

### § 9880.2. Exemptions from registration

The following persons are exempt from the requirement of registration:

(a) An employee of an automotive repair dealer if the employee repairs motor vehicles only as an employee.

(b) A person who solely engages in the business of repairing the motor vehicles of one or more commercial, industrial, or governmental establishments.

(c) A person who is registered pursuant to Chapter 20 (commencing with Section 9800) and whose work is limited to the installation or replacement of a motor vehicle radio, antenna, audio recorder, audio playback equipment, ignition interlock device, or burglar alarm.

(d) A person whose primary business is the wholesale supply of new or rebuilt automotive parts who solely engages in the remachining of individual automotive parts without compensation for warranty adjustments to those parts and who does not engage in repairing or diagnosing malfunctions of motor vehicles or motorcycles. “Primary business” means the business that accounts for the majority of the company’s gross sales. “Wholesale supply” means the sale, by a seller who possesses a California Resale Permit, of automotive parts to a retailer or jobber for the purpose of resale. However, a person described in this subdivision, prior to commencing work, shall do both of the following:

(1) Provide a notice containing the bureau’s toll-free telephone number to the customer that the person is not regulated by the bureau.

(2) Provide a written description of the remachining services to be performed to the customer.

Added Stats 1972 ch 1578 § 1.5. Amended Stats 1988 ch 480 § 2; Stats 1990 ch 1207 § 23 (AB 3242); Stats 1995 ch 572 § 1 (SB 827); Stats 1997 ch 107 § 1 (SB 107); Stats 1998 ch 970 § 204 (AB 2802); Stats 2012 ch 661 § 16 (SB 1576), effective January 1, 2013.

### § 9880.3. Priority of bureau; Protection of the public

Protection of the public shall be the highest priority for the Bureau of Automotive Repair in exercising its licensing, regulatory, and disciplinary functions. Whenever the protection of the public is inconsistent with other interests sought to be promoted, the protection of the public shall be paramount.

Added Stats 2002 ch 107 § 36 (AB 269).

## ARTICLE 2 Administration

### Section

9882. Bureau of Automotive Repair; Adoption of regulations

9882.1. Appointment, compensation, and supervision of personnel

9882.2. Chief of bureau

9882.3. Officials exercising director’s powers and duties

9882.4. Maintenance and availability of record of registered dealers; Bureau newsletter

9882.5. Investigation of violations; Complaint procedures; Compensation

9882.14. Standards for installation of ignition interlock devices

### § 9882. Bureau of Automotive Repair; Adoption of regulations

(a) There is in the Department of Consumer Affairs a Bureau of Automotive Repair under the supervision and control of the director. The duty of enforcing and administering this chapter is vested in the chief who is responsible to the director. The director may adopt and enforce those rules and regulations that he or she determines are reasonably necessary to carry out the purposes of this chapter and declaring the policy of the bureau, including a system for the issuance of citations for violations of this chapter as specified in Section 125.9. These rules and regulations shall be adopted pursuant to Chapter 3.5 (commencing with Section 11340) of Part 1 of Division 3 of Title 2 of the Government Code.

(b) In 2003 and every four years thereafter, the Joint Committee on Boards, Commissions, and Consumer Protection shall hold a public hearing to receive testimony from the Director of Consumer Affairs and the bureau. In those hearings, the bureau shall have the burden of demonstrating a compelling public need for the continued existence of the bureau and its regulatory program, and that its function is the least restrictive regulation consistent with the public health, safety, and welfare. The committee shall evaluate and review the effectiveness and efficiency of the bureau based on factors and minimum standards of performance that are specified in Section 473.4. The committee shall report its findings and recommendations as specified in Section 473.5. The bureau shall prepare an analysis and submit a report to the committee as specified in Section 473.2.

Added Stats 1971 ch 1578 § 1.5. Amended Stats 1995 ch 445 § 1 (SB 137); Stats 2004 ch 572 § 1 (SB 1542); Stats 2006 ch 760 § 9 (SB 1849), effective January 1, 2007.

### § 9882.1. Appointment, compensation, and supervision of personnel

The director in accordance with the State Civil Service Act, Part 2 (commencing with Section 18500) of Division 5 of Title 2 of the Government Code, may appoint and fix the compensation of such clerical, inspection, investigation, and auditing personnel, as well as an assistant chief, as may be necessary to carry out the provisions of this chapter except as otherwise provided by Section 159.5. All such personnel shall perform their respective duties under the supervision and the direction of the chief.

Added Stats 1971 ch 1578 § 1.5.

### § 9882.2. Chief of bureau

The Governor shall appoint, subject to confirmation by the Senate, a chief of the bureau at a salary to be fixed

and determined by the director with the approval of the Director of Finance. The chief shall serve under the direction and supervision of the director and at the pleasure of the Governor.

Before a chief is appointed, the Governor shall give due consideration to any person or persons recommended by the board.

Added Stats 1971 ch 1578 § 1.5.

**§ 9882.3. Officials exercising director’s powers and duties**

Every power granted to or duty imposed upon the director under this chapter may be exercised or performed in the name of the director by a deputy or assistant director or by the chief, subject to such conditions and limitations as the director may prescribe.

Added Stats 1971 ch 1578 § 1.5.

**§ 9882.4. Maintenance and availability of record of registered dealers; Bureau newsletter**

The director shall keep a complete record of all registered automotive repair dealers showing the names and addresses of all such dealers. A copy of the roster shall be made available to any person requesting it upon the payment of such sum as shall be established by the chief as sufficient to cover the costs thereof. The bureau shall send to registered automotive repair dealers, at least twice a year, a newsletter which may describe recently adopted regulations, proposed regulations, disciplinary hearings, and any other information that the director shall determine will assist the bureau in its enforcement program.

Added Stats 1971 ch 1578 § 1.5.

**§ 9882.5. Investigation of violations; Complaint procedures; Compensation**

The director shall on his or her own initiative or in response to complaints, investigate on a continuous basis and gather evidence of violations of this chapter and of any regulation adopted pursuant to this chapter, by any automotive repair dealer or automotive technician, whether registered or not, and by any employee, partner, officer, or member of any automotive repair dealer. The director shall establish procedures for accepting complaints from the public against any dealer or automotive technician. The director may suggest measures that, in the director’s judgment, would compensate for any damages suffered as a result of an alleged violation. If the dealer accepts the suggestions and performs accordingly, such fact shall be given due consideration in any subsequent disciplinary proceeding.

Added Stats 1971 ch 1578 § 1.5. Amended Stats 1998 ch 879 § 24 (SB 2238).

**§ 9882.14. Standards for installation of ignition interlock devices**

(a) The bureau shall cooperate with the Office of Traffic Safety and adopt standards for the installation, maintenance, and servicing of ignition interlock devices by automotive repair dealers.

(b) The manufacturers of ignition interlock devices shall comply with standards established by the bureau for the installation of those ignition interlock devices.

(c) The bureau may charge manufacturers of certified interlock ignition devices a fee to recover the cost of monitoring installation standards.

Added Stats 1990 ch 1403 § 2 (AB 2040), effective September 27, 1990. Amended Stats 2012 ch 661 § 17 (SB 1576), effective January 1, 2013.

**ARTICLE 3**

**Registration Procedure**

Section

- 9884. Registration fee and forms
- 9884.1. Application and fees when business has more than one facility
- 9884.2. Issuance of registration; Duties of director
- 9884.3. Termination of registration on nonpayment of renewal fee
- 9884.4. Termination of registration when information not current
- 9884.5. Cancellation of registration following failure to renew in three years after expiration; Renewal within three years
- 9884.6. Persons who must register
- 9884.7. Denial, suspension, revocation, or probation of registration
- 9884.76. Automotive repair dealers; Failure to restore airbag to original operating condition; Misdemeanor
- 9884.8. Recording on invoice
- 9884.9. Written estimates; Consent of customer; Acknowledgment; Authorization for charges in excess of estimate
- 9884.10. Return of replaced parts to customer
- 9884.11. Maintenance and inspection of records
- 9884.12. Provisions governing proceedings affecting registration
- 9884.13. Administrative jurisdiction after expiration of valid registration
- 9884.14. Enjoining violation
- 9884.15. Filing charges with district or city attorney
- 9884.16. Registration as prerequisite to lien or suit
- 9884.17. Sign placed in dealer locations
- 9884.18. Individual’s civil action against dealer
- 9884.19. Bureau’s regulations
- 9884.20. Limitations period for filing accusation against automotive repair dealers
- 9884.21. Probationary registration; Terms and conditions; Dismissed conviction; Evidence of rehabilitation; Standard terms
- 9884.22. Revocation, suspension, or denial of registration; Statement of reasons for denial; Copy of criminal history record; Hearings

**§ 9884. Registration fee and forms**

(a) An automotive repair dealer shall pay the fee required by this chapter for each place of business operated by the dealer in this state and shall register with the director upon forms prescribed by the director. The forms shall contain sufficient information to identify the automotive repair dealer, including name, address of each location, a statement by the dealer that each location is in an area that, pursuant to local zoning ordinances, permits the operation of a facility for the repair of motor vehicles, the dealer’s retail seller’s permit number, if a permit is required under the Sales and Use Tax Law (Part 1 (commencing with Section 6001), Division 2, Revenue and Taxation Code), and other identifying data that are prescribed by the director. If the business is to be carried on under a fictitious name, the fictitious name shall be stated. To the extent prescribed by the director, an automotive repair dealer shall identify the owners, directors, officers, partners, members, trustees, managers, and any other persons who directly or indirectly control or conduct the business. The forms shall include a statement signed by the dealer under penalty of perjury that the information provided is true.

(b) A state agency is not authorized or required by this section to enforce a city, county, regional, air pollution control district, or air quality management district rule

or regulation regarding the site or operation of a facility that repairs motor vehicles.

Added Stats 1971 ch 1578 § 1.5. Amended Stats 1995 ch 114 § 1 (AB 809); Stats 1997 ch 17 § 8 (SB 947); Stats 1998 ch 970 § 205 (AB 2802); Stats 1999 ch 983 § 11 (SB 1307).

**§ 9884.1. Application and fees when business has more than one facility**

Any business maintaining more than one automotive repair facility shall be permitted to file a single application annually, which along with the other information required by this article, clearly indicates the location of, and the individual in charge of, each facility. In that case, fees shall be paid for each location.

Added Stats 1971 ch 1578 § 1.5. Amended Stats 1992 ch 674 § 1 (SB 1792).

**§ 9884.2. Issuance of registration; Duties of director**

Upon receipt of the form properly filled out and receipt of the required fee, the director shall issue the registration and send a proof of issuance to the automotive repair dealer. The director shall by regulation prescribe conditions that he or she determines are necessary to ensure future compliance with this chapter, upon which a person, whose registration has previously been revoked or has previously been denied or who has committed acts prohibited by Section 9884.7 while an automotive repair dealer or mechanic or while an employee, partner, officer or member of an automotive repair dealer, may have his or her registration issued.

Added Stats 1971 ch 1578 § 1.5. Amended Stats 2009 ch 307 § 95 (SB 821), effective January 1, 2010.

**§ 9884.3. Termination of registration on nonpayment of renewal fee**

Every registration shall cease to be valid one year from the last day of the month in which registration was issued unless the automotive repair dealer has paid the renewal fee required by this chapter.

Added Stats 1971 ch 1578 § 1.5. Amended Stats 1998 ch 970 § 206 (AB 2802).

**§ 9884.4. Termination of registration when information not current**

A registration shall cease to be valid when the director finds that any of the information provided by the form specified in Section 9884, which the director by regulation deems material, ceases to be current.

Added Stats 1971 ch 1578 § 1.5.

**§ 9884.5. Cancellation of registration following failure to renew in three years after expiration; Renewal within three years**

A registration that is not renewed within three years following its expiration shall not be renewed, restored, or reinstated thereafter, and the delinquent registration shall be canceled immediately upon expiration of the three-year period.

An automotive repair dealer whose registration has been canceled by operation of this section shall obtain a new registration only if he or she again meets the requirements set forth in this chapter relating to regis-

tration, is not subject to denial under Section 480, and pays the applicable fees.

An expired registration may be renewed at any time within three years after its expiration upon the filing of an application for renewal on a form prescribed by the bureau and the payment of all accrued renewal and delinquency fees. Renewal under this section shall be effective on the date on which the application is filed and all renewal and delinquency fees are paid. If so renewed, the registration shall continue in effect through the expiration date of the current registration year as provided in Section 9884.3, at which time the registration shall be subject to renewal.

Added Stats 1998 ch 970 § 206.5 (AB 2802).

**§ 9884.6. Persons who must register**

(a) It is unlawful for any person to be an automotive repair dealer unless that person has registered in accordance with this chapter and unless that registration is currently valid.

(b) A person who, for compensation, adjusts, installs, or tests retrofit systems for purposes of Chapter 6 (commencing with Section 44200) of Part 5 of Division 26 of the Health and Safety Code is an automotive repair dealer for purposes of this chapter.

Added Stats 1971 ch 1578 § 1.5. Amended Stats 1985 ch 1138 § 1.

**§ 9884.7. Denial, suspension, revocation, or probation of registration**

(a) The director, where the automotive repair dealer cannot show there was a bona fide error, may deny, suspend, revoke, or place on probation the registration of an automotive repair dealer for any of the following acts or omissions related to the conduct of the business of the automotive repair dealer, which are done by the automotive repair dealer or any automotive technician, employee, partner, officer, or member of the automotive repair dealer.

(1) Making or authorizing in any manner or by any means whatever any statement written or oral which is untrue or misleading, and which is known, or which by the exercise of reasonable care should be known, to be untrue or misleading.

(2) Causing or allowing a customer to sign any work order that does not state the repairs requested by the customer or the automobile's odometer reading at the time of repair.

(3) Failing or refusing to give to a customer a copy of any document requiring his or her signature, as soon as the customer signs the document.

(4) Any other conduct that constitutes fraud.

(5) Conduct constituting gross negligence.

(6) Failure in any material respect to comply with the provisions of this chapter or regulations adopted pursuant to it.

(7) Any willful departure from or disregard of accepted trade standards for good and workmanlike repair in any material respect, which is prejudicial to another without consent of the owner or his or her duly authorized representative.

(8) Making false promises of a character likely to influence, persuade, or induce a customer to authorize the repair, service, or maintenance of automobiles.

(9) Having repair work done by someone other than the dealer or his or her employees without the knowledge or consent of the customer unless the dealer can demonstrate that the customer could not reasonably have been notified.

(10) Conviction of a violation of Section 551 of the Penal Code.

Upon denying a registration, the director shall notify the applicant thereof, in writing, by personal service or mail addressed to the address of the applicant set forth in the application, and the applicant shall be given a hearing under Section 9884.12 if, within 30 days thereafter, he or she files with the bureau a written request for hearing, otherwise the denial is deemed affirmed.

(b) Except as provided for in subdivision (c), if an automotive repair dealer operates more than one place of business in this state, the director pursuant to subdivision (a) shall only suspend, revoke, or place on probation the registration of the specific place of business which has violated any of the provisions of this chapter. This violation, or action by the director, shall not affect in any manner the right of the automotive repair dealer to operate his or her other places of business.

(c) Notwithstanding subdivision (b), the director may suspend, revoke, or place on probation the registration for all places of business operated in this state by an automotive repair dealer upon a finding that the automotive repair dealer has, or is, engaged in a course of repeated and willful violations of this chapter, or regulations adopted pursuant to it.

Added Stats 1971 ch 1578 § 1.5. Amended Stats 1973 ch 57 § 1; Stats 1992 ch 675 § 1 (AB 3067); Stats 1998 ch 879 § 25 (SB 2238); Stats 2006 ch 760 § 10 (SB 1849), effective January 1, 2007; Stats 2009 ch 307 § 96 (SB 821), effective January 1, 2010.

**§ 9884.76. Automotive repair dealers; Failure to restore airbag to original operating condition; Misdemeanor**

Notwithstanding Section 9889.20, an automotive repair dealer who prepares a written estimate for repairs pursuant to Section 9884.9 that includes replacement of a deployed airbag that is part of an inflatable restraint system, and who fails to restore the airbag that is part of an inflatable restraint system to its original operating condition, where the customer has paid for the replacement of the deployed airbag as provided in the estimate, is guilty of a misdemeanor punishable by a fine of five thousand dollars (\$5,000) or by imprisonment in a county jail for one year, or by both that fine and imprisonment.

Added Stats 2011 ch 430 § 1 (SB 869), effective January 1, 2012.

**§ 9884.8. Recording on invoice**

All work done by an automotive repair dealer, including all warranty work, shall be recorded on an invoice and shall describe all service work done and parts supplied. Service work and parts shall be listed separately on the invoice, which shall also state separately the subtotal prices for service work and for parts, not including sales tax, and shall state separately the sales tax, if any, applicable to each. If any used, rebuilt, or reconditioned parts are supplied, the invoice shall clearly state that fact. If a part of a component system is composed of new and used, rebuilt or reconditioned

parts, that invoice shall clearly state that fact. The invoice shall include a statement indicating whether any crash parts are original equipment manufacturer crash parts or nonoriginal equipment manufacturer aftermarket crash parts. One copy of the invoice shall be given to the customer and one copy shall be retained by the automotive repair dealer.

Added Stats 1971 ch 1578 § 1.5. Amended Stats 1972 ch 967 § 1, effective August 16, 1972; Stats 2000 ch 336 § 1 (AB 1778).

**§ 9884.9. Written estimates; Consent of customer; Acknowledgment; Authorization for charges in excess of estimate**

(a) The automotive repair dealer shall give to the customer a written estimated price for labor and parts necessary for a specific job. No work shall be done and no charges shall accrue before authorization to proceed is obtained from the customer. No charge shall be made for work done or parts supplied in excess of the estimated price without the oral or written consent of the customer that shall be obtained at some time after it is determined that the estimated price is insufficient and before the work not estimated is done or the parts not estimated are supplied. Written consent or authorization for an increase in the original estimated price may be provided by electronic mail or facsimile transmission from the customer. The bureau may specify in regulation the procedures to be followed by an automotive repair dealer if an authorization or consent for an increase in the original estimated price is provided by electronic mail or facsimile transmission. If that consent is oral, the dealer shall make a notation on the work order of the date, time, name of person authorizing the additional repairs, and telephone number called, if any, together with a specification of the additional parts and labor and the total additional cost, and shall do either of the following:

(1) Make a notation on the invoice of the same facts set forth in the notation on the work order.

(2) Upon completion of the repairs, obtain the customer's signature or initials to an acknowledgment of notice and consent, if there is an oral consent of the customer to additional repairs, in the following language:

"I acknowledge notice and oral approval of an increase in the original estimated price.

\_\_\_\_\_  
(signature or initials)"

Nothing in this section shall be construed as requiring an automotive repair dealer to give a written estimated price if the dealer does not agree to perform the requested repair.

(b) The automotive repair dealer shall include with the written estimated price a statement of any automotive repair service that, if required to be done, will be done by someone other than the dealer or his or her employees. No service shall be done by other than the dealer or his or her employees without the consent of the customer, unless the customer cannot reasonably be notified. The dealer shall be responsible, in any case, for any service in the same manner as if the dealer or his or her employees had done the service.

(c) In addition to subdivisions (a) and (b), an automotive repair dealer, when doing auto body or collision repairs, shall provide an itemized written estimate for



all parts and labor to the customer. The estimate shall describe labor and parts separately and shall identify each part, indicating whether the replacement part is new, used, rebuilt, or reconditioned. Each crash part shall be identified on the written estimate and the written estimate shall indicate whether the crash part is an original equipment manufacturer crash part or a nonoriginal equipment manufacturer aftermarket crash part.

(d) A customer may designate another person to authorize work or parts supplied in excess of the estimated price, if the designation is made in writing at the time that the initial authorization to proceed is signed by the customer. The bureau may specify in regulation the form and content of a designation and the procedures to be followed by the automotive repair dealer in recording the designation. For the purposes of this section, a designee shall not be the automotive repair dealer providing repair services or an insurer involved in a claim that includes the motor vehicle being repaired, or an employee or agent or a person acting on behalf of the dealer or insurer.

Added Stats 1971 ch 1578 § 1.5. Amended Stats 1973 ch 57 § 2, ch 1056 § 1; Stats 1978 ch 549 § 1; Stats 2000 ch 336 § 2 (AB 1778); Stats 2004 ch 874 § 2 (AB 1079).

#### § 9884.10. Return of replaced parts to customer

Upon request of the customer at the time the work order is taken, the automotive repair dealer shall return replaced parts to the customer at the time of the completion of the work excepting such parts as may be exempt because of size, weight, or other similar factors from this requirement by regulations of the department and excepting such parts as the automotive repair dealer is required to return to the manufacturer or distributor under a warranty arrangement. If such parts must be returned to the manufacturer or distributor, the dealer at the time the work order is taken shall offer to show, and upon acceptance of such offer or request shall show, such parts to the customer upon completion of the work, except that the dealer shall not be required to show a replaced part when no charge is being made for the replacement part.

Added Stats 1971 ch 1578 § 1.5.

#### § 9884.11. Maintenance and inspection of records

Each automotive repair dealer shall maintain any records that are required by regulations adopted to carry out this chapter. Those records shall be open for reasonable inspection by the chief or other law enforcement officials. All of those records shall be maintained for at least three years.

Added Stats 1971 ch 1578 § 1.5. Amended Stats 1992 ch 674 § 2 (SB 1792).

#### § 9884.12. Provisions governing proceedings affecting registration

All proceedings to deny, suspend, revoke, or place on probation a registration shall be conducted pursuant to Chapter 5 (commencing with Section 11500) of Part 1 of Division 3 of Title 2 of the Government Code.

Added Stats 1971 ch 1578 § 1.5. Amended Stats 2009 ch 307 § 97 (SB 821), effective January 1, 2010.

#### § 9884.13. Administrative jurisdiction after expiration of valid registration

The expiration of a valid registration shall not deprive the director or chief of jurisdiction to proceed with any investigation or disciplinary proceeding against an automotive repair dealer or to render a decision invalidating a registration temporarily or permanently.

Added Stats 1971 ch 1578 § 1.5.

#### § 9884.14. Enjoining violation

The superior court in and for the county wherein any person carries on, or attempts to carry on, a business as an automotive repair dealer or as a mechanic in violation of the provisions of this chapter, or any regulation made pursuant to this chapter, shall, on application of the director or the chief, issue an injunction or other appropriate order restraining such conduct. This section shall be cumulative to and shall not prohibit the enforcement of any other law.

The proceedings under this section shall be governed by Chapter 3 (commencing with Section 525) of Title 7 of Part 2 of the Code of Civil Procedure, except that the director or chief shall not be required to allege facts necessary to show or tending to show lack of an adequate remedy at law or irreparable injury.

Added Stats 1971 ch 1578 § 1.5. Amended Stats 1982 ch 517 § 39.

#### § 9884.15. Filing charges with district or city attorney

The director may file charges with the district attorney or city attorney against any automotive repair dealer who violates the provisions of this chapter or any regulation made pursuant to this chapter.

Added Stats 1971 ch 1578 § 1.5.

#### § 9884.16. Registration as prerequisite to lien or suit

No person required to have a valid registration under the provisions of this chapter shall have the benefit of any lien for labor or materials or the right to sue on a contract for motor vehicle repairs done by him unless he has such a valid registration.

Added Stats 1971 ch 1578 § 1.5.

#### § 9884.17. Sign placed in dealer locations

The bureau shall design and approve of a sign which shall be placed in all automotive repair dealer locations in a place and manner conspicuous to the public. That sign shall give notice that inquiries concerning service may be made to the bureau and shall contain the telephone number and Internet Web site address of the bureau. The sign shall also give notice that the customer is entitled to a return of replaced parts upon his or her request therefor at the time the work order is taken.

Added Stats 1971 ch 1578 § 1.5. Amended Stats 1992 ch 674 § 3 (SB 1792); Stats 2004 ch 572 § 3 (SB 1542).

#### § 9884.18. Individual's civil action against dealer

Nothing in the provisions of this chapter shall prohibit the bringing of a civil action against an automotive repair dealer by an individual.

Added Stats 1971 ch 1578 § 1.5.

**§ 9884.19. Bureau's regulations**

The bureau may adopt, amend or repeal in accordance with the provisions of Chapter 4.5 (commencing with Section 11371), Part 1, Division 3, Title 2 of the Government Code such regulations as may be reasonably necessary to carry out the provisions of this chapter in the protection of the public from fraudulent or misleading advertising by an automotive repair dealer, including formulation of definitions, to the extent feasible, of the terms "fraud," "guarantee," and words of like import, and of "negligence," and guidelines for the suspension and revocation of licenses. The bureau shall distribute to each registered repair dealer copies of this chapter and of the regulations adopted pursuant to this chapter.

Added Stats 1971 ch 1578 § 1.5.

**§ 9884.20. Limitations period for filing accusation against automotive repair dealers**

All accusations against automotive repair dealers shall be filed within three years after the performance of the act or omission alleged as the ground for disciplinary action, except that with respect to an accusation alleging fraud or misrepresentation as a ground for disciplinary action, the accusation may be filed within two years after the discovery, by the bureau, of the alleged facts constituting the fraud or misrepresentation.

Added Stats 2007 ch 354 § 65 (SB 1047), effective January 1, 2008.

**§ 9884.21. Probationary registration; Terms and conditions; Dismissed conviction; Evidence of rehabilitation; Standard terms**

(a) Notwithstanding any other provision of law, the director may, in his or her sole discretion, issue a probationary registration to an applicant subject to terms and conditions deemed appropriate by the director, including, but not limited to, the following:

- (1) Continuing medical, psychiatric, or psychological treatment.
- (2) Ongoing participation in a specified rehabilitation program.
- (3) Abstention from the use of alcohol or drugs.
- (4) Compliance with all provisions of this chapter.

(b)(1) Notwithstanding any other provision of law, and for purposes of this section, when deciding whether to issue a probationary registration, the director shall request that an applicant with a dismissed conviction provide proof of that dismissal and shall give special consideration to applicants whose convictions have been dismissed pursuant to Section 1203.4 or 1203.4a of the Penal Code.

(2) The director shall also take into account and consider any other reasonable documents or individual character references provided by the applicant that may serve as evidence of rehabilitation as deemed appropriate by the director.

(c) The director may modify or terminate the terms and conditions imposed on the probationary registration upon receipt of a petition from the applicant or registrant.

(d) For purposes of issuing a probationary registration to qualified new applicants, the director shall develop standard terms of probation that shall include, but not be limited to, the following:

(1) A three-year limit on the individual probationary registration.

(2) A process to obtain a standard registration for applicants who were issued a probationary registration.

(3) Supervision requirements.

(4) Compliance and quarterly reporting requirements.

Added Stats 2008 ch 675 § 13 (AB 2423), effective January 1, 2009.

**§ 9884.22. Revocation, suspension, or denial of registration; Statement of reasons for denial; Copy of criminal history record; Hearings**

(a) Notwithstanding any other provision of law, the director may revoke, suspend, or deny at any time any registration required by this article on any of the grounds for disciplinary action provided in this article. The proceedings under this article shall be conducted in accordance with Chapter 5 (commencing with Section 11500) of Part 1 of Division 3 of Title 2 of the Government Code, and the director shall have all the powers granted therein.

(b) The director may deny a registration to an applicant on any of the grounds specified in Section 480.

(c) In addition to the requirements provided in Sections 485 and 486, upon denial of an application for registration to an applicant, the director shall provide a statement of reasons for the denial that does the following:

(1) Evaluates evidence of rehabilitation submitted by the applicant, if any.

(2) Provides the director's criteria relating to rehabilitation, formulated pursuant to Section 482, that takes into account the age and severity of the offense, and the evidence relating to participation in treatment or other rehabilitation programs.

(3) If the director's decision was based on the applicant's prior criminal conviction, justifies the director's denial of a registration and conveys the reasons why the prior criminal conviction is substantially related to the qualifications, functions, or duties of a registered automotive repair dealer.

(d) Commencing July 1, 2009, all of the following shall apply:

(1) If the denial of a registration is due at least in part to the applicant's state or federal criminal history record, the director shall, in addition to the information provided pursuant to paragraph (3) of subdivision (c), provide to the applicant a copy of his or her criminal history record if the applicant makes a written request to the director for a copy, specifying an address to which it is to be sent.

(A) The state or federal criminal history record shall not be modified or altered from its form or content as provided by the Department of Justice.

(B) The criminal history record shall be provided in such a manner as to protect the confidentiality and privacy of the applicant's criminal history record and the criminal history record shall not be made available by the director to any employer.

(C) The director shall retain a copy of the applicant's written request and a copy of the response sent to the applicant, which shall include the date and the address to which the response was sent.

(2) The director shall make that information available upon request by the Department of Justice or the Federal Bureau of Investigation.

(e) Notwithstanding Section 487, the director shall conduct a hearing of a registration denial within 90 days of receiving an applicant's request for a hearing. For all other hearing requests, the director shall determine when the hearing shall be conducted.

Added Stats 2008 ch 675 § 14 (AB 2423), effective January 1, 2009.

## ARTICLE 4

### Revenue

#### Section

9886. Vehicle and Inspection Repair Fund

9886.1. Director's report to State Controller and payment of revenues into State Treasury

9886.2. Availability of funding

9886.3. Registration fee schedule

9886.4. Payments from fund

#### § 9886. Vehicle and Inspection Repair Fund

All fees and revenues collected pursuant to this chapter and Chapter 5 (commencing with Section 44000) of Part 5 of Division 26 of the Health and Safety Code shall be paid into the State Treasury to the credit of the Vehicle Inspection and Repair Fund, which is hereby created.

Added Stats 1971 ch 1578 § 1.5. Amended Stats 1988 ch 1544 § 1.

#### § 9886.1. Director's report to State Controller and payment of revenues into State Treasury

The director shall report to the Controller at the beginning of each month, for the month preceding, the amount and source of all fees and revenues received by the department pursuant to this chapter and Chapter 5 (commencing with Section 44000) of Part 5 of Division 26 of the Health and Safety Code, and at that time shall pay the entire amount of those fees and revenues into the State Treasury for credit to the Vehicle Inspection and Repair Fund.

Added Stats 1971 ch 1578 § 1.5. Amended Stats 1988 ch 1544 § 2.

#### § 9886.2. Availability of funding

The money in the Vehicle Inspection and Repair Fund necessary for the administration of this chapter and Chapter 5 (commencing with Section 44000) of Part 5 of Division 26 of the Health and Safety Code is available to the department, when appropriated for those purposes.

Added Stats 1971 ch 1578 § 1.5. Amended Stats 1988 ch 1544 § 3; Stats 1989 ch 1154 § 1; Stats 1998 ch 970 § 207 (AB 2802).

#### § 9886.3. Registration fee schedule

The fees prescribed by this chapter shall be set by the director in an amount estimated to provide for the administration of this chapter within the limits of the following schedule:

(a) The automotive repair dealer registration fee is not more than two hundred dollars (\$200), for each, place of business in this state.

(b) The annual renewal fee for an automotive repair dealer registration shall not be more than two hundred dollars (\$200) for each place of business in this state, if renewed prior to its expiration date.

(c) The renewal fee for a registration that is not renewed prior to its expiration date shall be 1½ times the renewal fee required for a registration renewal prior to

its expiration date, but not more than the renewal fee plus fifty dollars (\$50).

Added Stats 1971 ch 1578 § 1.5. Amended Stats 1978 ch 1161 § 486; Stats 1981 ch 380 § 1; Stats 1991 ch 386 § 2 (SB 290).

#### § 9886.4. Payments from fund

All salaries, expenses, or costs incurred or sustained pursuant to this chapter and Chapter 5 (commencing with Section 44000) of Part 5 of Division 26 of the Health and Safety Code shall be payable only out of the Vehicle Inspection and Repair Fund.

Added Stats 1971 ch 1578 § 1.5. Amended Stats 1988 ch 1544 § 4.

## ARTICLE 5

### Licenses

#### Section

9887.1. Licensing for lamp and brake adjusting stations

9887.2. Application and fees

9887.3. Nontransferability, and cancellation and replacement or duplication, of licenses

9887.4. Illegality of violation of regulation

#### § 9887.1. Licensing for lamp and brake adjusting stations

The director shall have the authority to issue licenses for official lamp and brake adjusting stations and shall license lamp and brake adjusters. The licenses shall be issued in accordance with this chapter and regulations adopted by the director pursuant thereto. The director shall establish by regulation the terms of adjusters' licenses as are necessary for the practical administration of the provisions relating to adjusters, but those terms shall not be for less than one nor more than four years. Licenses may be renewed upon application and payment of the renewal fees if the application for renewal is made within the 30-day period prior to the date of expiration. Persons whose licenses have expired shall immediately cease the activity requiring a license, but the director shall accept applications for renewal during the 30-day period following the date of expiration if they are accompanied by a new license fee. In no case shall a license be renewed where the application is received more than 30 days after the date of expiration.

Added Stats 1971 ch 1578 § 1.5. Amended Stats 1990 ch 1433 § 1 (SB 1874).

#### § 9887.2. Application and fees

Each application for a new or renewal license shall be accompanied by a fee of ten dollars (\$10) for a new license or five dollars (\$5) for a renewal license. The application shall be made upon a form furnished by the director. It shall contain such information concerning the applicant's background and experience as the director may prescribe, in addition to other information required by law. No license as a lamp or brake adjuster shall be issued or renewed unless the applicant has demonstrated his or her experience and qualifications in accordance with such standards and examinations as the director may prescribe.

Added Stats 1971 ch 1578 § 1.5. Amended Stats 1972 ch 967 § 2, effective August 16, 1972; Stats 1973 ch 635 § 1; Stats 1990 ch 1433 § 2 (SB 1874).

**§ 9887.3. Nontransferability, and cancellation and replacement or duplication, of licenses**

(a) Licenses issued by the director shall not be transferable.

(b) In the event of a change of name of a licensee, not involving a change of ownership, or of a change of address of a licensed station, the license shall be returned to the director for cancellation, and a new license application form shall be submitted. The director shall cancel the returned license and issue a new license for the unexpired term without fee.

(c) If the owner of a licensed station desires to vacate the license in favor of another license permitting a greater or lesser scope of activity, the license to be vacated shall be returned to the director for cancellation and an application shall be submitted for the new license accompanied by the ten-dollar (\$10) new license fee.

(d) In the event of loss, destruction, or mutilation of a license issued by the director, the person to whom it was issued may obtain a duplicate upon furnishing satisfactory proof of such fact and paying a fee of two dollars (\$2). Any person who loses a license issued by the director and who, after obtaining a duplicate, finds the original license shall immediately surrender the original license to the director.

Added Stats 1971 ch 1578 § 1.5. Amended Stats 1972 ch 967 § 3, effective August 16, 1972.

**§ 9887.4. Illegality of violation of regulation**

It is unlawful to violate any regulation adopted by the director pursuant to Articles 5, 6, and 7 of this chapter.

Added Stats 1971 ch 1578 § 1.5.

**ARTICLE 6**

**Lamp and Brake Adjusting Stations**

Section

- 9888.1. Definitions
- 9888.2. Adoption of regulations; Approval of testing equipment and laboratories
- 9888.3. Required licensing of stations and adjusters
- 9888.4. Licensing of, and certification by, fleet owner stations

**§ 9888.1. Definitions**

As used in this chapter:

(a) "Station" means a lamp adjusting station or a brake adjusting station.

(b) "Licensed station" means a station licensed by the bureau pursuant to this chapter.

(c) "Licensed adjuster" means a person licensed by the bureau for adjusting lamps in licensed lamp adjusting stations or for adjusting brakes in licensed brake adjusting stations.

Added Stats 1971 ch 1578 § 1.5. Amended Stats 1980 ch 1134 § 1; Stats 1990 ch 1433 § 4 (SB 1874).

**§ 9888.2. Adoption of regulations; Approval of testing equipment and laboratories**

The director shall adopt regulations which prescribe the equipment and other qualifications of any station as a condition to licensing the station as an official station for adjusting lamps or brakes and shall prescribe the qualifications of adjusters employed therein.

After consulting with the Department of the California Highway Patrol, the director may, by regulation, approve testing and calibrating equipment, which is capable of measuring or calibrating the standards imposed by statute and by rules and regulations, for use in official stations, and may approve the testing laboratories and the equipment they use to certify the performance of testing and calibrating equipment.

Added Stats 1971 ch 1578 § 1.5. Amended Stats 1973 ch 635 § 2; Stats 1980 ch 1134 § 2; Stats 1981 ch 524 § 1, effective September 16, 1981; Stats 1990 ch 1433 § 5 (SB 1874).

**§ 9888.3. Required licensing of stations and adjusters**

No person shall operate an "official" lamp or brake adjusting station unless a license therefor has been issued by the director. No person shall issue, or cause or permit to be issued, any certificate purporting to be an official lamp adjustment certificate unless he or she is a licensed lamp adjuster or an official brake adjustment certificate unless he or she is a licensed brake adjuster.

Added Stats 1971 ch 1578 § 1.5. Amended Stats 1980 ch 1134 § 3; Stats 1981 ch 524 § 2, effective September 16, 1981; Stats 1990 ch 1433 § 6 (SB 1874).

**§ 9888.4. Licensing of, and certification by, fleet owner stations**

An owner of a fleet of three or more vehicles who is not an interstate carrier may be licensed by the director as a licensed station, if the owner complies with the rules and regulations of the bureau. Those fleet owner stations shall not certify the adjustment of lamps or brakes except on vehicles which constitute the owner's fleet.

Added Stats 1971 ch 1578 § 1.5. Amended Stats 1978 ch 1162 § 1; Stats 1990 ch 1433 § 7 (SB 1874).

**ARTICLE 7**

**Denial, Suspension and Revocation**

Section

- 9889.1. Authority of director; Provisions governing proceedings
- 9889.2. Grounds for denial of license
- 9889.3. Grounds for disciplinary action against licensee
- 9889.4. Conviction, and license suspension, revocation, or refusal thereon
- 9889.5. Permitted disciplinary actions
- 9889.6. Surrender of revoked or suspended license
- 9889.7. Continuance of director's jurisdiction
- 9889.8. Period of limitations for filing accusations
- 9889.9. Revocation or suspension of additional license
- 9889.10. Reinstatement of suspended or revoked license

**§ 9889.1. Authority of director; Provisions governing proceedings**

Any license issued pursuant to Articles 5 and 6, may be suspended or revoked by the director. The director may refuse to issue a license to any applicant for the reasons set forth in Section 9889.2. The proceedings under this article shall be conducted in accordance with Chapter 5 (commencing with Section 11500) of Part 1 of Division 3 of Title 2 of the Government Code, and the director shall have all the powers granted therein.

Added Stats 1971 ch 1578 § 1.5.

**§ 9889.2. Grounds for denial of license**

The director may deny a license if the applicant or any partner, officer, or director thereof:

(a) Fails to meet the qualifications established by the bureau pursuant to Articles 5 and 6 of this chapter for the issuance of the license applied for.

(b) Was previously the holder of a license issued under this chapter which license has been revoked and never reissued or which license was suspended and the terms of the suspension have not been fulfilled.

(c) Has committed any act which, if committed by any licensee, would be grounds for the suspension or revocation of a license issued pursuant to this chapter.

(d) Has committed any act involving dishonesty, fraud, or deceit whereby another is injured or whereby the applicant has benefited.

(e) Has acted in the capacity of a licensed person or firm under this chapter without having a license therefor.

(f) Has entered a plea of guilty or nolo contendere to, or been found guilty of, or been convicted of a crime substantially related to the qualifications, functions and duties of the license holder in question, and the time for appeal has elapsed or the judgment of conviction has been affirmed on appeal, irrespective of an order granting probation following such conviction, suspending the imposition of sentence, or of a subsequent order under the provisions of Section 1203.4 of the Penal Code allowing such person to withdraw his plea of guilty and to enter a plea of not guilty, or setting aside the plea or verdict of guilty, or dismissing the accusation or information.

Added Stats 1971 ch 1578 § 1.5. Amended Stats 1978 ch 1161 § 487.

### § 9889.3. Grounds for disciplinary action against licensee

The director may suspend, revoke, or take other disciplinary action against a license as provided in this article if the licensee or any partner, officer, or director thereof:

(a) Violates any section of the Business and Professions Code that relates to his or her licensed activities.

(b) Is convicted of any crime substantially related to the qualifications, functions, or duties of the licenseholder in question.

(c) Violates any of the regulations promulgated by the director pursuant to this chapter.

(d) Commits any act involving dishonesty, fraud, or deceit whereby another is injured.

(e) Has misrepresented a material fact in obtaining a license.

(f) Aids or abets an unlicensed person to evade the provisions of this chapter.

(g) Fails to make and keep records showing his or her transactions as a licensee, or fails to have the records available for inspection by the director or his or her duly authorized representative for a period of not less than three years after completion of any transaction to which the records refer, or refuses to comply with a written request of the director to make the record available for inspection.

(h) Violates or attempts to violate the provisions of this chapter relating to the particular activity for which he or she is licensed.

(i) Is convicted of a violation of Section 551 of the Penal Code.

Added Stats 1971 ch 1578 § 1.5. Amended Stats 1978 ch 1161 § 488; Stats 1992 ch 675 § 2 (AB 3067); Stats 2009 ch 307 § 98 (SB 821), effective January 1, 2010.

### § 9889.4. Conviction, and license suspension, revocation, or refusal thereon

A plea or verdict of guilty or a conviction following a plea of nolo contendere is deemed to be a conviction within the meaning of this article. The director may order the license suspended or revoked, or may decline to issue a license, when the time for appeal has elapsed, or the judgment of conviction has been affirmed on appeal, or when an order granting probation is made suspending the imposition of sentence, irrespective of a subsequent order under the provisions of Section 1203.4 of the Penal Code allowing such person to withdraw his plea of guilty and to enter a plea of not guilty, or setting aside the verdict of guilty, or dismissing the accusation, information or indictment.

Added Stats 1971 ch 1578 § 1.5.

### § 9889.5. Permitted disciplinary actions

The director may take disciplinary action against any licensee after a hearing as provided in this article by any of the following:

(a) Imposing probation upon terms and conditions to be set forth by the director.

(b) Suspending the license.

(c) Revoking the license.

Added Stats 1971 ch 1578 § 1.5.

### § 9889.6. Surrender of revoked or suspended license

Upon the effective date of any order of suspension or revocation of any license governed by this chapter, the licensee shall surrender the license to the director.

Added Stats 1971 ch 1578 § 1.5.

### § 9889.7. Continuance of director's jurisdiction

The expiration or suspension of a license by operation of law or by order or decision of the director or a court of law, or the voluntary surrender of a license by a licensee shall not deprive the director of jurisdiction to proceed with any investigation of or action or disciplinary proceedings against such licensee, or to render a decision suspending or revoking such license.

Added Stats 1971 ch 1578 § 1.5.

### § 9889.8. Period of limitations for filing accusations

All accusations against licensees shall be filed within three years after the act or omission alleged as the ground for disciplinary action, except that with respect to an accusation alleging a violation of subdivision (d) of Section 9889.3, the accusation may be filed within two years after the discovery by the bureau of the alleged facts constituting the fraud or misrepresentation prohibited by that section.

Added Stats 1971 ch 1578 § 1.5. Amended Stats 1998 ch 970 § 209 (AB 2802); Stats 2001 ch 357 § 3 (AB 1560).

### § 9889.9. Revocation or suspension of additional license

When any license has been revoked or suspended following a hearing under the provisions of this article, any additional license issued under Articles 5 and 6 of

this chapter in the name of the licensee may be likewise revoked or suspended by the director.

Added Stats 1971 ch 1578 § 1.5.

**§ 9889.10. Reinstatement of suspended or revoked license**

After suspension of the license upon any of the grounds set forth in this article, the director may reinstate the license upon proof of compliance by the applicant with all provisions of the decision as to reinstatement. After revocation of a license upon any of the grounds set forth in this article, the license shall not be reinstated or reissued within a period of one year after the effective date of revocation.

Added Stats 1971 ch 1578 § 1.5.

**ARTICLE 8**

**Lamp and Brake Adjustment Certificates**

Section

- 9889.15. Definitions
- 9889.16. Lamp or brake adjustment certificate
- 9889.19. Charging fees for certificates

**§ 9889.15. Definitions**

As used in this article, “station,” “licensed station,” and “licensed adjuster” have the same meaning as defined in Article 6 (commencing with Section 9888.1).

Added Stats 1971 ch 1578 § 1.5. Amended Stats 1975 ch 957 § 1; Stats 1990 ch 1433 § 9 (SB 1874).

**§ 9889.16. Lamp or brake adjustment certificate**

Whenever a licensed adjuster in a licensed station upon an inspection or after an adjustment, made in conformity with the instructions of the bureau, determines that the lamps or the brakes upon any vehicle conform with the requirements of the Vehicle Code, he shall, when requested by the owner or driver of the vehicle, issue a certificate of adjustment on a form prescribed by the director, which certificate shall contain the date of issuance, the make and registration number of the vehicle, the name of the owner of the vehicle, and the official license of the station.

Added Stats 1971 ch 1578 § 1.5.

**§ 9889.19. Charging fees for certificates**

The director may charge a fee for lamp and brake adjustment certificates furnished to licensed stations. The fee charged shall be established by regulation and shall not produce a total estimated revenue which, together with license fees or certification fees charged pursuant to Sections 9886.3, 9887.2, and 9887.3, is in excess of the estimated total cost to the bureau of the administration of this chapter. The fee charged by licensed stations for lamp and brake adjustment certificates shall be the same amount the director charges.

Added Stats 1971 ch 1578 § 1.5. Amended Stats 1972 ch 967 § 4, effective August 16, 1972; Stats 1977 ch 1038 § 2, effective September 23, 1977; Stats 1982 ch 815 § 1, operative July 1, 1983; Stats 1990 ch 1433 § 12 (SB 1874).

**ARTICLE 9**

**Penalties**

Section

- 9889.20. Misdemeanor offense and punishment therefor
- 9889.21. Infraction, and punishment therefor
- 9889.22. Perjury

**§ 9889.20. Misdemeanor offense and punishment therefor**

Except as otherwise provided in Section 9889.21, any person who fails to comply in any respect with the provisions of this chapter is guilty of a misdemeanor and punishable by a fine not exceeding one thousand dollars (\$1,000), or by imprisonment not exceeding six months, or by both that fine and imprisonment.

Added Stats 1971 ch 1578 § 1.5. Amended Stats 1982 ch 815 § 2, operative July 1, 1983; Stats 2010 ch 328 § 20 (SB 1330), effective January 1, 2011.

**§ 9889.21. Infraction, and punishment therefor**

Any person who violates any provision of Articles 5, 6, and 7 of this chapter is guilty of an infraction and punishable as specified in subdivision (a) of Section 42001 of the Vehicle Code.

Added Stats 1971 ch 1578 § 1.5.

**§ 9889.22. Perjury**

The willful making of any false statement or entry with regard to a material matter in any oath, affidavit, certificate of compliance or noncompliance, or application form which is required by this chapter or Chapter 5 (commencing with Section 44000) of Part 5 of Division 26 of the Health and Safety Code constitutes perjury and is punishable as provided in the Penal Code.

Added Stats 1986 ch 951 § 5.

**ARTICLE 10.5**

**Auto Body Repair**

Section

- 9889.50. Legislative findings
- 9889.51. “Auto body repair shop”
- 9889.52. Application for registration
- 9889.53. Inclusion of repairer’s identification number on check issued under collision insurance policy

**§ 9889.50. Legislative findings**

The Legislature finds the following:

- (1) Thousands of California automobile owners each year require repair of their vehicles as a result of collision or other damage.
- (2) California automobile owners are suffering direct and indirect harm through unsafe, improper, incompetent, and fraudulent auto body repairs.
- (3) There is a lack of proper training and equipment that auto body repair shops need to meet the demands of the highly evolved and sophisticated automobile manufacturing industry.
- (4) California has no minimum standards or requirements for auto body repair shops.
- (5) Existing laws currently regulating the auto body industry could be strengthened.

(6) There is a compelling need to increase competency and standards for the auto body repair industry.

Added Stats 1995 ch 445 § 2 (SB 137).

**§ 9889.51. “Auto body repair shop”**

“Auto body repair shop” means a place of business operated by an automotive repair dealer where automotive collision repair or reconstruction of automobile or truck bodies is performed.

Added Stats 1995 ch 445 § 2 (SB 137).

**§ 9889.52. Application for registration**

An application for registration pursuant to Section 9884 shall designate that the applicant is registering as an auto body repair shop if the applicant intends to perform auto body repair. In addition, an application for registration to operate an auto body repair shop shall include a written statement signed under penalty of perjury that the applicant has been issued licenses or permits, if required by law, including, but not limited to, all of the following:

- (1) A city or county business license.
- (2) A State Board of Equalization identification or resale permit number.
- (3) An Environmental Protection Agency hazardous waste permit number.
- (4) An Air Quality Management District spray booth permit number.

Added Stats 1995 ch 445 § 2 (SB 137).

**§ 9889.53. Inclusion of repairer’s identification number on check issued under collision insurance policy**

A check or draft issued to a repairer pursuant to Section 560 of the Insurance Code shall include the repairer’s registration number or taxpayer identification number.

Added Stats 1995 ch 445 § 2 (SB 137).

**ARTICLE 11**

**Auto Body Repair Study**

Section

9889.66. Registration form

9889.68. Identification requirement for insurance check or draft issued to repairer

**§ 9889.66. Registration form**

The form for registration pursuant to Section 9884 shall contain sufficient information to enable the Bureau of Automotive Repair to identify all registrants performing automotive collision repair work.

Added Stats 1992 ch 479 § 3 (SB 1688).

**§ 9889.68. Identification requirement for insurance check or draft issued to repairer**

Any auto insurance company check or draft issued to a repairer pursuant to Insurance Code Section 560 shall include the repairer’s registration number or Tax Payer Identification Number.

Added Stats 1992 ch 479 § 3 (SB 1688).

**DIVISION 5**

**Weights and Measures**

**CHAPTER 14.5**

**Service Stations**

Section

13650. “Service station”

13651. Provision of air, water, pressure gauge, and restrooms; Exceptions

13652. Punishment for intentional violations; Compliance after receiving notice

13653. Enforcement

13660. Refueling service for disabled person

**§ 13650. “Service station”**

“Service station,” as used in this chapter, means any establishment which offers for sale or sells gasoline or other motor vehicle fuel to the public.

Added Stats 1984 ch 1561 § 1.

**§ 13651. Provision of air, water, pressure gauge, and restrooms; Exceptions**

(a)(1) On and after January 1, 2000, every service station in this state shall provide, during operating hours, and make available at no cost to customers who purchase motor vehicle fuel, water, compressed air, and a gauge for measuring air pressure, to the public for use in servicing any passenger vehicle, as defined in Section 465 of the Vehicle Code, or any commercial vehicle, as defined in Section 260 of the Vehicle Code, with an unladen weight of 6,000 pounds or less.

(2) Every service station in this state shall display, at a conspicuous place on, at, or near the dispensing apparatus, at least one clearly visible sign which shall read as follows: “CALIFORNIA LAW REQUIRES THIS STATION TO PROVIDE FREE AIR AND WATER FOR AUTOMOTIVE PURPOSES TO ITS CUSTOMERS WHO PURCHASE MOTOR VEHICLE FUEL. IF YOU HAVE A COMPLAINT NOTIFY THE STATION ATTENDANT AND/OR CALL THIS TOLL-FREE TELEPHONE NUMBER: 1 (800) — —.” This sign shall meet the requirements of Sections 13473 and 13474 with regard to letter size and contrast. As used in this paragraph, automotive purposes does not include the washing of vehicles.

(b)(1) On and after January 1, 1990, every service station in this state located within 660 feet of an accessible right-of-way of an interstate or primary highway, as defined in Sections 5215 and 5220, shall provide, during business hours public restrooms for use by its customers. Service stations shall not charge customers separately for the use of restroom facilities.

(2) The public restroom shall not be temporary or portable but shall be permanent and shall include separate facilities for men and women, each with toilets and sinks suitable for use by disabled persons in accordance with Section 19955.5 of the Health and Safety Code and Title 24 of the California Code of Regulations. However,

a service station not located along an interstate highway and in a rural area, as defined by Section 101 of Title 23 of the United States Code, and where the annualized average daily traffic count is 2,500 vehicles or less, is only required to provide a single restroom to be used by both men and women unless the local legislative body or, upon designation by the local legislative body, the local building official determines and finds, based upon traffic studies and local or seasonal tourist patterns, that a single restroom would be inadequate to serve the public. In that event, the single restroom exemption shall not apply. The single restroom shall contain a toilet, urinal, and sink suitable for use by disabled persons as required by the Americans With Disabilities Act and Title 24 of the California Code of Regulations. The single restroom shall be equipped with a locking mechanism to be operated by the user of the restroom and the restroom shall be maintained in a clean and sanitary manner.

(3) This subdivision does not apply to service stations that are operational prior to January 1, 1990, and that would be obligated to construct permanent restroom facilities to comply with this subdivision.

(4) For the purposes of this subdivision, "customer" means a person who purchases any product available for sale on the premises of the service station, including items not related to the repairing or servicing of a motor vehicle.

(c) Every service station in this state shall display, at a conspicuous place on, at, or near the dispensing apparatus or at or near the point of sale, at least one clearly visible sign showing a list of applicable state and federal fuel taxes per gallon of motor vehicle fuel sold from the dispensing apparatus. The sign may display the federal excise tax rate as "up to \$.184."

(d)(1) The Division of Measurement Standards of the Department of Food and Agriculture shall, no later than January 1, 2001, establish a toll-free customer complaint telephone number. The toll-free telephone number thereby established shall be printed on the sign required pursuant to paragraph (2) of subdivision (a).

(2) Notwithstanding any other provision of law, employees of the Division of Measurement Standards, upon inspection, or upon notice of a complaint forwarded pursuant to this section, are empowered to investigate a complaint against a service station for lack of free air and water and issue a citation to the station, and to collect a fine of two hundred fifty dollars (\$250) per valid complaint, unless the citation is challenged in court. No citation shall be issued if the air and water equipment is in good working order upon initial inspection, or if they are repaired to the satisfaction of the inspecting entity within 10 working days of the initial inspection. In addition, no citation based on nonfunctional air and water equipment shall be issued if the service station can establish that the equipment has been the target of repeated vandalism, substantiated by three or more police reports within six months detailing the vandalism.

Added Stats 1984 ch 1561 § 1. Amended Stats 1988 ch 1498 § 1; Stats 1989 ch 491 § 1; Stats 1990 ch 555 § 1 (AB 3265); Stats 1996 ch 489 § 2 (SB 1466); Stats 1999 ch 583 § 2 (AB 531); Stats 2003 ch 63 § 2 (SB 671).

### § 13652. Punishment for intentional violations; Compliance after receiving notice

(a) Any person who intentionally violates any provision of this chapter or any regulation promulgated pur-

suant thereto is guilty of an infraction, and, upon conviction, shall be punished by a fine not to exceed fifty dollars (\$50) for each day that the person violates the provision or regulation.

(b) The failure of an owner or manager of a service station to have adequate water and air facilities available for use by the public, or to provide permanent public restrooms for use by its customers, as required by subdivision (b) of Section 13651, for five consecutive working days, constitutes a rebuttable presumption affecting the burden of proof that the owner or manager has intentionally violated this chapter. This subdivision does not apply to restrooms rendered inoperable as a result of vandalism or plumbing problems that may not be readily repaired.

(c) Notwithstanding any other provision of this chapter, no person shall be guilty of the infraction specified in subdivision (a) if that person, within seven days after receiving notification from the city attorney, district attorney, or Attorney General of any violation of this chapter, makes whatever changes are necessary to comply with the requirements of this chapter.

Added Stats 1984 ch 1561 § 1. Amended Stats 1989 ch 491 § 2.

### § 13653. Enforcement

Notwithstanding any other provision of law, this chapter may be enforced by the city attorney, district attorney, or Attorney General.

Added Stats 1984 ch 1561 § 1.

### § 13660. Refueling service for disabled person

(a) Every person, firm, partnership, association, trustee, or corporation that operates a service station shall provide, upon request, refueling service to a disabled driver of a vehicle that displays a disabled person's plate or placard, or a disabled veteran's plate, issued by the Department of Motor Vehicles. The price charged for the motor vehicle fuel shall be no greater than that which the station otherwise would charge the public generally to purchase motor vehicle fuel without refueling service.

(b) Any person or entity specified in subdivision (a) that operates a service station shall be exempt from this section during hours when:

(1) Only one employee is on duty.

(2) Only two employees are on duty, one of whom is assigned exclusively to the preparation of food.

As used in this subdivision, the term "employee" does not include a person employed by an unrelated business that is not owned or operated by the entity offering motor vehicle fuel for sale to the general public.

(c)(1) Every person, firm, partnership, association, trustee, or corporation required to provide refueling service for persons with disabilities pursuant to this section shall post the following notice, or a notice with substantially similar language, in a manner and single location that is conspicuous to a driver seeking refueling service:

"Service to Disabled Persons

Disabled individuals properly displaying a disabled person's plate or placard, or a disabled veteran's plate, issued by the Department of Motor Vehicles, are entitled



to request and receive refueling service at this service station for which they may not be charged more than the self-service price.”

(2) If refueling service is limited to certain hours pursuant to an exemption set forth in subdivision (b), the notice required by paragraph (1) shall also specify the hours during which refueling service for persons with disabilities is available.

(3) Every person, firm, partnership, association, trustee, or corporation that, consistent with subdivision (b), does not provide refueling service for persons with disabilities during any hours of operation shall post the following notice in a manner and single location that is conspicuous to a driver seeking refueling service:

“No Service for Disabled Persons

This service station does not provide refueling service for disabled individuals.”

(4) The signs required by paragraphs (1) and (3) shall also include a statement indicating that drivers seeking information about enforcement of laws related to refueling services for persons with disabilities may call one or more toll-free telephone numbers specified and maintained by the Department of Rehabilitation. By January 31, 1999, the Director of the Department of Rehabilitation shall notify the State Board of Equalization of the toll-free telephone number or numbers to be included on the signs required by this subdivision. At least one of these toll-free telephone numbers shall be accessible to persons using telephone devices for the deaf. The State Board of Equalization shall publish information regarding the toll-free telephone numbers as part of its annual notification required by subdivision (i). In the event that the toll-free telephone number or numbers change, the Director of the Department of Rehabilitation shall notify the State Board of Equalization of the new toll-free telephone number or numbers to be used.

(d) During the county sealer’s normal petroleum product inspection of a service station, the sealer shall verify that a sign has been posted in accordance with subdivision (c). If a sign has not been posted, the sealer shall issue a notice of violation to the owner or agent. The sealer shall be reimbursed, as prescribed by the department, from funds provided under Chapter 14. If substantial, repeated violations of subdivision (c) are noted at the same service station, the sealer shall refer the matter to the appropriate local law enforcement agency.

(e) The local law enforcement agency shall, upon the verified complaint of any person or public agency, investigate the actions of any person, firm, partnership, association, trustee, or corporation alleged to have violated this section. If the local law enforcement agency determines that there has been a denial of service in violation of this section, or a substantial or repeated failure to comply with subdivision (c), the agency shall levy the fine prescribed in subdivision (f).

(f) Any person who, as a responsible managing individual setting service policy of a service station, or as an employee acting independently against the set service policy, acts in violation of this section is guilty of an infraction punishable by a fine of one hundred dollars (\$100) for the first offense, two hundred dollars (\$200) for the second offense, and five hundred dollars (\$500) for each subsequent offense.

(g) In addition to those matters referred pursuant to subdivision (e), the city attorney, the district attorney, or the Attorney General, upon his or her own motion, may investigate and prosecute alleged violations of this section. Any person or public agency may also file a verified complaint alleging violation of this section with the city attorney, district attorney, or Attorney General.

(h) Enforcement of this section may be initiated by any intended beneficiary of the provisions of this section, his or her representatives, or any public agency that exercises oversight over the service station, and the action shall be governed by Section 1021.5 of the Code of Civil Procedure.

(i) An annual notice setting forth the provisions of this section shall be provided by the State Board of Equalization to every person, firm, partnership, association, trustee, or corporation that operates a service station.

(j) A notice setting forth the provisions of this section shall be printed on each disabled person’s placard issued by the Department of Motor Vehicles on and after January 1, 1999. A notice setting forth the provisions of this section shall be provided to each person issued a disabled person’s or disabled veteran’s plate on and after January 1, 1998.

(k) For the purposes of this action “refueling service” means the service of pumping motor vehicle fuel into the fuel tank of a motor vehicle.

Added Stats 1997 ch 836 § 3 (AB 1277). Amended Stats 1998 ch 878 § 55 (SB 2239), ch 879 § 26.4 (SB 2238).

## DIVISION 7

### General Business Regulations

#### PART 2

#### Preservation and Regulation of Competition

#### CHAPTER 5

#### Enforcement

Section  
17200. Definition  
17201. Person

Section  
17201.5. “Board within the Department of Consumer Affairs”; “Local consumer affairs agency”  
17202. Specific or preventive relief  
17203. Injunctive relief; Court orders  
17204. Actions for Injunctions by Attorney General, District Attorney, County Counsel, and City Attorneys  
17205. Cumulative penalties  
17206. Civil penalty for violation of chapter  
17206.1. Additional civil penalty; Acts against senior citizens or disabled persons  
17207. Violation of injunction  
17208. Limitation of actions  
17209. Notice of issue in action before appellate court

**§ 17200. Definition**

As used in this chapter, unfair competition shall mean and include any unlawful, unfair or fraudulent business act or practice and unfair, deceptive, untrue or misleading advertising and any act prohibited by Chapter 1 (commencing with Section 17500) of Part 3 of Division 7 of the Business and Professions Code.

Added Stats 1977 ch 299 § 1. Amended Stats 1992 ch 430 § 2 (SB 1586).

**§ 17201. Person**

As used in this chapter, the term person shall mean and include natural persons, corporations, firms, partnerships, joint stock companies, associations and other organizations of persons.

Added Stats 1977 ch 299 § 1.

**§ 17201.5. “Board within the Department of Consumer Affairs”; “Local consumer affairs agency”**

As used in this chapter:

(a) “Board within the Department of Consumer Affairs” includes any commission, bureau, division, or other similarly constituted agency within the Department of Consumer Affairs.

(b) “Local consumer affairs agency” means and includes any city or county body which primarily provides consumer protection services.

Added Stats 1979 ch 897 § 1.

**§ 17202. Specific or preventive relief**

Notwithstanding Section 3369 of the Civil Code, specific or preventive relief may be granted to enforce a penalty, forfeiture, or penal law in a case of unfair competition.

Added Stats 1977 ch 299 § 1.

**§ 17203. Injunctive relief; Court orders**

Any person who engages, has engaged, or proposes to engage in unfair competition may be enjoined in any court of competent jurisdiction. The court may make such orders or judgments, including the appointment of a receiver, as may be necessary to prevent the use or employment by any person of any practice which constitutes unfair competition, as defined in this chapter, or as may be necessary to restore to any person in interest any money or property, real or personal, which may have been acquired by means of such unfair competition. Any person may pursue representative claims or relief on behalf of others only if the claimant meets the standing requirements of Section 17204 and complies with Section 382 of the Code of Civil Procedure, but these limitations do not apply to claims brought under this chapter by the Attorney General, or any district attorney, county counsel, city attorney, or city prosecutor in this state.

Added Stats 1977 ch 299 § 1. Amended Stats 1992 ch 430 § 3 (SB 1586). Amendment approved by voters, Prop. 64 § 2, effective November 3, 2004.

**§ 17204. Actions for Injunctions by Attorney General, District Attorney, County Counsel, and City Attorneys**

Actions for relief pursuant to this chapter shall be prosecuted exclusively in a court of competent jurisdiction by the Attorney General or a district attorney or by

a county counsel authorized by agreement with the district attorney in actions involving violation of a county ordinance, or by a city attorney of a city having a population in excess of 750,000, or by a city attorney in a city and county or, with the consent of the district attorney, by a city prosecutor in a city having a full-time city prosecutor in the name of the people of the State of California upon their own complaint or upon the complaint of a board, officer, person, corporation, or association, or by a person who has suffered injury in fact and has lost money or property as a result of the unfair competition.

Added Stats 1977 ch 299 § 1. Amended Stats 1991 ch 1195 § 1 (SB 709), ch 1196 § 1 (AB 1755); Stats 1992 ch 385 § 1 (SB 1911); Stats 1993 ch 926 § 2 (AB 2205). Amendment approved by voters, Prop. 64 § 3, effective November 3, 2004; Stats 2007 ch 17 § 1 (SB 376), effective January 1, 2008; Stats 2008 ch 179 § 23 (SB 1498), effective January 1, 2009.

**§ 17205. Cumulative penalties**

Unless otherwise expressly provided, the remedies or penalties provided by this chapter are cumulative to each other and to the remedies or penalties available under all other laws of this state.

Added Stats 1977 ch 299 § 1.

**§ 17206. Civil penalty for violation of chapter**

(a) Any person who engages, has engaged, or proposes to engage in unfair competition shall be liable for a civil penalty not to exceed two thousand five hundred dollars (\$2,500) for each violation, which shall be assessed and recovered in a civil action brought in the name of the people of the State of California by the Attorney General, by any district attorney, by any county counsel authorized by agreement with the district attorney in actions involving violation of a county ordinance, by any city attorney of a city having a population in excess of 750,000, by any city attorney of any city and county, or, with the consent of the district attorney, by a city prosecutor in any city having a full-time city prosecutor, in any court of competent jurisdiction.

(b) The court shall impose a civil penalty for each violation of this chapter. In assessing the amount of the civil penalty, the court shall consider any one or more of the relevant circumstances presented by any of the parties to the case, including, but not limited to, the following: the nature and seriousness of the misconduct, the number of violations, the persistence of the misconduct, the length of time over which the misconduct occurred, the willfulness of the defendant’s misconduct, and the defendant’s assets, liabilities, and net worth.

(c) If the action is brought by the Attorney General, one-half of the penalty collected shall be paid to the treasurer of the county in which the judgment was entered, and one-half to the General Fund. If the action is brought by a district attorney or county counsel, the penalty collected shall be paid to the treasurer of the county in which the judgment was entered. Except as provided in subdivision (e), if the action is brought by a city attorney or city prosecutor, one-half of the penalty collected shall be paid to the treasurer of the city in which the judgment was entered, and one-half to the treasurer of the county in which the judgment was entered. The aforementioned funds shall be for the

exclusive use by the Attorney General, the district attorney, the county counsel, and the city attorney for the enforcement of consumer protection laws.

(d) The Unfair Competition Law Fund is hereby created as a special account within the General Fund in the State Treasury. The portion of penalties that is payable to the General Fund or to the Treasurer recovered by the Attorney General from an action or settlement of a claim made by the Attorney General pursuant to this chapter or Chapter 1 (commencing with Section 17500) of Part 3 shall be deposited into this fund. Moneys in this fund, upon appropriation by the Legislature, shall be used by the Attorney General to support investigations and prosecutions of California's consumer protection laws, including implementation of judgments obtained from such prosecutions or investigations and other activities which are in furtherance of this chapter or Chapter 1 (commencing with Section 17500) of Part 3. Notwithstanding Section 13340 of the Government Code, any civil penalties deposited in the fund pursuant to the National Mortgage Settlement, as provided in Section 12531 of the Government Code, are continuously appropriated to the Department of Justice for the purpose of offsetting General Fund costs incurred by the Department of Justice.

(e) If the action is brought at the request of a board within the Department of Consumer Affairs or a local consumer affairs agency, the court shall determine the reasonable expenses incurred by the board or local agency in the investigation and prosecution of the action.

Before any penalty collected is paid out pursuant to subdivision (c), the amount of any reasonable expenses incurred by the board shall be paid to the Treasurer for deposit in the special fund of the board described in Section 205. If the board has no such special fund, the moneys shall be paid to the Treasurer. The amount of any reasonable expenses incurred by a local consumer affairs agency shall be paid to the general fund of the municipality or county that funds the local agency.

(f) If the action is brought by a city attorney of a city and county, the entire amount of the penalty collected shall be paid to the treasurer of the city and county in which the judgment was entered for the exclusive use by the city attorney for the enforcement of consumer protection laws. However, if the action is brought by a city attorney of a city and county for the purposes of civil enforcement pursuant to Section 17980 of the Health and Safety Code or Article 3 (commencing with Section 11570) of Chapter 10 of Division 10 of the Health and Safety Code, either the penalty collected shall be paid entirely to the treasurer of the city and county in which the judgment was entered or, upon the request of the city attorney, the court may order that up to one-half of the penalty, under court supervision and approval, be paid for the purpose of restoring, maintaining, or enhancing the premises that were the subject of the action, and that the balance of the penalty be paid to the treasurer of the city and county.

Added Stats 1977 ch 299 § 1. Amended Stats 1979 ch 897 § 2; Stats 1991 ch 1195 § 2 (SB 709), ch 1196 § 2 (AB 1755); Stats 1992 ch 430 § 4 (SB 1586); Stats 1997 ch 17 § 11 (SB 947). Amendment approved by voters, Prop. 64 § 4, effective November 3, 2004. Amended Stats 2005 ch 74 § 23 (AB 139), effective July 19, 2005; Stats 2007 ch 17 § 2 (SB 376), effective January 1, 2008; Stats 2012 ch 32 § 1 (SB 1006), effective June 27, 2012.

### § 17206.1. Additional civil penalty; Acts against senior citizens or disabled persons

(a)(1) In addition to any liability for a civil penalty pursuant to Section 17206, a person who violates this chapter, and the act or acts of unfair competition are perpetrated against one or more senior citizens or disabled persons, may be liable for a civil penalty not to exceed two thousand five hundred dollars (\$2,500) for each violation, which may be assessed and recovered in a civil action as prescribed in Section 17206.

(2) Subject to subdivision (d), any civil penalty shall be paid as prescribed by subdivisions (b) and (c) of Section 17206.

(b) As used in this section, the following terms have the following meanings:

(1) "Senior citizen" means a person who is 65 years of age or older.

(2) "Disabled person" means a person who has a physical or mental impairment that substantially limits one or more major life activities.

(A) As used in this subdivision, "physical or mental impairment" means any of the following:

(i) A physiological disorder or condition, cosmetic disfigurement, or anatomical loss substantially affecting one or more of the following body systems: neurological; musculoskeletal; special sense organs; respiratory, including speech organs; cardiovascular; reproductive; digestive; genitourinary; hemic and lymphatic; skin; or endocrine.

(ii) A mental or psychological disorder, including intellectual disability, organic brain syndrome, emotional or mental illness, and specific learning disabilities.

"Physical or mental impairment" includes, but is not limited to, diseases and conditions including orthopedic, visual, speech, and hearing impairment, cerebral palsy, epilepsy, muscular dystrophy, multiple sclerosis, cancer, heart disease, diabetes, intellectual disability, and emotional illness.

(B) "Major life activities" means functions that include caring for one's self, performing manual tasks, walking, seeing, hearing, speaking, breathing, learning, and working.

(c) In determining whether to impose a civil penalty pursuant to subdivision (a) and the amount thereof, the court shall consider, in addition to any other appropriate factors, the extent to which one or more of the following factors are present:

(1) Whether the defendant knew or should have known that his or her conduct was directed to one or more senior citizens or disabled persons.

(2) Whether the defendant's conduct caused one or more senior citizens or disabled persons to suffer any of the following: loss or encumbrance of a primary residence, principal employment, or source of income; substantial loss of property set aside for retirement, or for personal or family care and maintenance; or substantial loss of payments received under a pension or retirement plan or a government benefits program, or assets essential to the health or welfare of the senior citizen or disabled person.

(3) Whether one or more senior citizens or disabled persons are substantially more vulnerable than other members of the public to the defendant's conduct because of age, poor health or infirmity, impaired under-

standing, restricted mobility, or disability, and actually suffered substantial physical, emotional, or economic damage resulting from the defendant's conduct.

(d) A court of competent jurisdiction hearing an action pursuant to this section may make orders and judgments as necessary to restore to a senior citizen or disabled person money or property, real or personal, that may have been acquired by means of a violation of this chapter. Restitution ordered pursuant to this subdivision shall be given priority over recovery of a civil penalty designated by the court as imposed pursuant to subdivision (a), but shall not be given priority over a civil penalty imposed pursuant to subdivision (a) of Section 17206. If the court determines that full restitution cannot be made to those senior citizens or disabled persons, either at the time of judgment or by a future date determined by the court, then restitution under this subdivision shall be made on a pro rata basis depending on the amount of loss.

Added Stats 1988 ch 823 § 1. Amended Stats 2006 ch 538 § 23 (SB 1852), effective January 1, 2007; Stats 2012 ch 448 § 3 (AB 2370), effective January 1, 2013, ch 457 § 3 (SB 1381), effective January 1, 2013.

#### § 17207. Violation of injunction

(a) Any person who intentionally violates any injunction prohibiting unfair competition issued pursuant to Section 17203 shall be liable for a civil penalty not to exceed six thousand dollars (\$6,000) for each violation. Where the conduct constituting a violation is of a continuing nature, each day of that conduct is a separate and distinct violation. In determining the amount of the civil penalty, the court shall consider all relevant circumstances, including, but not limited to, the extent of the harm caused by the conduct constituting a violation, the nature and persistence of that conduct, the length of time over which the conduct occurred, the assets, liabilities, and net worth of the person, whether corporate or individual, and any corrective action taken by the defendant.

(b) The civil penalty prescribed by this section shall be assessed and recovered in a civil action brought in any county in which the violation occurs or where the injunction was issued in the name of the people of the State of California by the Attorney General or by any district attorney, any county counsel authorized by agreement with the district attorney in actions involving violation of a county ordinance, or any city attorney in any court of competent jurisdiction within his or her jurisdiction without regard to the county from which the original injunction was issued. An action brought pursuant to this section to recover civil penalties shall take precedence over all civil matters on the calendar of the court except those matters to which equal precedence on the calendar is granted by law.

(c) If such an action is brought by the Attorney General, one-half of the penalty collected pursuant to this section shall be paid to the treasurer of the county in which the judgment was entered, and one-half to the State Treasurer. If brought by a district attorney or county counsel the entire amount of the penalty collected shall be paid to the treasurer of the county in which the judgment is entered. If brought by a city attorney or city prosecutor, one-half of the penalty shall be paid to the

treasurer of the county in which the judgment was entered and one-half to the city, except that if the action was brought by a city attorney of a city and county the entire amount of the penalty collected shall be paid to the treasurer of the city and county in which the judgment is entered.

(d) If the action is brought at the request of a board within the Department of Consumer Affairs or a local consumer affairs agency, the court shall determine the reasonable expenses incurred by the board or local agency in the investigation and prosecution of the action.

Before any penalty collected is paid out pursuant to subdivision (c), the amount of the reasonable expenses incurred by the board shall be paid to the State Treasurer for deposit in the special fund of the board described in Section 205. If the board has no such special fund, the moneys shall be paid to the State Treasurer. The amount of the reasonable expenses incurred by a local consumer affairs agency shall be paid to the general fund of the municipality or county which funds the local agency.

Added Stats 1977 ch 299 § 1. Amended Stats 1979 ch 897 § 3; Stats 1991 ch 1195 § 3 (SB 709), ch 1196 § 3 (AB 1755).

#### § 17208. Limitation of actions

Any action to enforce any cause of action pursuant to this chapter shall be commenced within four years after the cause of action accrued. No cause of action barred under existing law on the effective date of this section shall be revived by its enactment.

Added Stats 1977 ch 299 § 1.

#### § 17209. Notice of issue in action before appellate court

If a violation of this chapter is alleged or the application or construction of this chapter is in issue in any proceeding in the Supreme Court of California, a state court of appeal, or the appellate division of a superior court, each person filing any brief or petition with the court in that proceeding shall serve, within three days of filing with the court, a copy of that brief or petition on the Attorney General, directed to the attention of the Consumer Law Section at a service address designated on the Attorney General's official Web site for service of papers under this section or, if no service address is designated, at the Attorney General's office in San Francisco, California, and on the district attorney of the county in which the lower court action or proceeding was originally filed. Upon the Attorney General's or district attorney's request, each person who has filed any other document, including all or a portion of the appellate record, with the court in addition to a brief or petition shall provide a copy of that document without charge to the Attorney General or the district attorney within five days of the request. The time for service may be extended by the Chief Justice or presiding justice or judge for good cause shown. No judgment or relief, temporary or permanent, shall be granted or opinion issued until proof of service of the brief or petition on the Attorney General and district attorney is filed with the court.

Added Stats 1992 ch 385 § 2 (SB 1911). Amended Stats 1998 ch 931 § 9 (SB 2139), effective September 28, 1998; Stats 2004 ch 529 § 4 (AB 1711).

**PART 3**  
**Representations to the Public**

**CHAPTER 1**  
**Advertising**

**ARTICLE 1**  
**False Advertising in General**

## Section

17500. False or misleading statements generally
- 17500.1. Prohibition against enactment of rule, regulation, or code of ethics restricting or prohibiting advertising not violative of law
- 17500.3. Solicitation of sales at residence or by telephone
- 17500.5. Advertisements as to quantity of article to be sold to single customer
17501. Value determinations; Former price advertisements
17502. Exemption of broadcasting stations and publishers from provisions of article
17503. [No section of this number.]
17504. Advertisement of price of goods or services sold in multiple units
17505. Misrepresentation as to nature of business
- 17505.2. Requirements for representing oneself as recreation therapist; Civil action for violation
17506. "Person"
- 17506.5. "Board within the Department of Consumer Affairs"; "Local consumer affairs agency"
17507. Disclosure of price differentials respecting more than one article of merchandise or type of service within same class
17508. Purportedly fact-based or brand-comparison advertisements
17509. Advertisements soliciting purchase of product conditioned on purchase of different product; Price disclosure; Good faith exemption for publishers

**§ 17500. False or misleading statements generally**

It is unlawful for any person, firm, corporation or association, or any employee thereof with intent directly or indirectly to dispose of real or personal property or to perform services, professional or otherwise, or anything of any nature whatsoever or to induce the public to enter into any obligation relating thereto, to make or disseminate or cause to be made or disseminated before the public in this state, or to make or disseminate or cause to be made or disseminated from this state before the public in any state, in any newspaper or other publication, or any advertising device, or by public outcry or proclamation, or in any other manner or means whatever, including over the Internet, any statement, concerning that real or personal property or those services, professional or otherwise, or concerning any circumstance or matter of fact connected with the proposed performance or disposition thereof, which is untrue or misleading, and which is known, or which by the exercise of reasonable care should be known, to be untrue or misleading, or for any person, firm, or corporation to so make or disseminate or cause to be so made or disseminated any such statement as part of a plan or scheme with the intent not to sell that personal property or those services, professional or otherwise, so advertised at the price stated therein, or as so advertised. Any violation of the provisions of this section is a misdemeanor punishable by imprisonment in the county jail not exceeding six months, or by a fine not exceeding two thousand five

hundred dollars (\$2,500), or by both that imprisonment and fine.

Added Stats 1941 ch 63 § 1. Amended Stats 1955 ch 1358 § 1; Stats 1976 ch 1125 § 4; Stats 1979 ch 492 § 1; Stats 1998 ch 599 § 2.5 (SB 597).

**§ 17500.1. Prohibition against enactment of rule, regulation, or code of ethics restricting or prohibiting advertising not violative of law**

Notwithstanding any other provision of law, no trade or professional association, or state agency, state board, or state commission within the Department of Consumer Affairs shall enact any rule, regulation, or code of professional ethics which shall restrict or prohibit advertising by any commercial or professional person, firm, partnership or corporation which does not violate the provisions of Section 17500 of the Business and Professions Code, or which is not prohibited by other provisions of law.

The provisions of this section shall not apply to any rules or regulations heretofore or hereafter formulated pursuant to Section 6076.

Added Stats 1949 ch 186 § 1. Amended Stats 1971 ch 716 § 180; Stats 1979 ch 653 § 12.

**§ 17500.3. Solicitation of sales at residence or by telephone**

(a) It is unlawful for any person to solicit a sale or order for sale of goods or services at the residence of a prospective buyer, in person or by means of telephone, without clearly, affirmatively and expressly revealing at the time the person initially contacts the prospective buyer, and before making any other statement, except a greeting, or asking the prospective buyer any other questions, that the purpose of the contact is to effect a sale, by doing all of the following:

(1) Stating the identity of the person making the solicitation.

(2) Stating the trade name of the person represented by the person making the solicitation.

(3) Stating the kind of goods or services being offered for sale.

(4) And, in the case of an "in person" contact, the person making the solicitation shall, in addition to meeting the requirements of paragraphs (1), (2) and (3), show or display identification which states the information required by paragraphs (1) and (2) as well as the address of the place of business of one of such persons so identified.

(b) It is unlawful for any person, in soliciting a sale or order for the sale of goods or services at the residence of a prospective buyer, in person or by telephone, to use any plan, scheme, or ruse which misrepresents his true status or mission for the purpose of making such sale or order for the sale of goods or services.

(c) In addition to any other penalties or remedies applicable to violations of this section, the intentional violation of this section shall entitle persons bound to a contract, when there was a sales approach or presentation or both in which such intentional violation of this section took place, to damages of two times the amount of the sale price or up to two hundred fifty dollars (\$250), whichever is greater, but in no case shall such damages be less than fifty dollars (\$50); provided, however, that as a condition precedent to instituting such action hereun-

der against the person represented by the person making the solicitation, the aggrieved party shall, in writing, demand that the person represented by the solicitor terminate such contract and return any and all payments made thereunder, and that the person represented by the solicitor shall have refused within a reasonable time, such termination and return. If the person represented by the person making the solicitation elects to terminate, he shall return to the aggrieved party payments received for any and all goods, and for services not rendered, and upon return of such payments, the aggrieved party shall return any and all goods received under the contract. For the purposes of this section, a reasonable time shall mean 20 business days from the date of demand. This subdivision shall not apply to a cause of action commenced under any other provision of law, including, but not limited to, a cause of action commenced pursuant to Section 382 of the Code of Civil Procedure or Section 1781 of the Civil Code.

Any rights under this subdivision shall be waived if subsequent to the signing of the contract the party bound by the contract states that identification, as required by this section, was given.

(d) Persons represented by the person making the solicitation shall keep and maintain copies of all demands for termination for violation of this section for a period of one year from date of receipt. Failure to maintain such records shall create a presumption affecting the burden of proof that demand for termination had been properly made.

(e) Where any provision of law provides a penalty for the violation of any offense specified in this section, it shall be a defense to the imposition of such penalty as to any defendant who did not commit the act or acts constituting the offense that such defendant did not know, and with the exercise of reasonable care could not have known, that the act was committed, which constitutes the violation of this section.

(f) As used in this section "person" includes any individual, firm, partnership, corporation, association or other organization, but does not include any nonprofit charitable organization, or any person selling any intangibles, or any items defined in Section 1590(a)(1), of Title 18 of the California Administrative Code as it read on July 15, 1972.

(g) This section shall not prohibit nor authorize the enactment by the governing body of any city, county, or city and county, of ordinances relating to home solicitations which are more restrictive of such solicitation than the provisions of this section.

Added Stats 1972 ch 1415 § 1. Amended Stats 1975 ch 343 § 1.

#### **§ 17500.5. Advertisements as to quantity of article to be sold to single customer**

(a) It is unlawful for any person, firm, corporation or association to falsely represent by advertisement the quantity of any article so advertised that will be sold to any one customer on his demand in a single transaction, and willfully or negligently to fail to include in such advertisement a statement that any restriction that is in fact put upon the quantity of any article so advertised that is sold or offered for sale to any one customer on his demand in a single transaction.

(b) Any person, firm, corporation, or association who, by means of such false or negligent advertisement or publicity, induces any individual retail purchaser and consumer to enter any place of business designated therein seeking to buy any article so advertised or publicized, and then refuses to sell to such person the article at the price advertised in any quantity then available for sale on said premises, shall be liable to each person so induced and refused, for the losses and expenses thereby incurred, and the sum of fifty dollars (\$50) in addition thereto.

(c) Nothing in this section shall affect any right a seller may have to refuse to extend credit to a customer, and this section shall not be applicable to a customer purchasing for resale.

(d) The provisions of subdivision (b) are applicable only to actions brought in the name of, and on behalf of, a single plaintiff and shall not be applicable in multiple plaintiff or class actions.

Added Stats 1970 ch 1121 § 1.

#### **§ 17501. Value determinations; Former price advertisements**

For the purpose of this article the worth or value of any thing advertised is the prevailing market price, wholesale if the offer is at wholesale, retail if the offer is at retail, at the time of publication of such advertisement in the locality wherein the advertisement is published.

No price shall be advertised as a former price of any advertised thing, unless the alleged former price was the prevailing market price as above defined within three months next immediately preceding the publication of the advertisement or unless the date when the alleged former price did prevail is clearly, exactly and conspicuously stated in the advertisement.

Added Stats 1941 ch 63 § 1.

#### **§ 17502. Exemption of broadcasting stations and publishers from provisions of article**

This article does not apply to any visual or sound radio broadcasting station, to any internet service provider or commercial online service, or to any publisher of a newspaper, magazine, or other publication, who broadcasts or publishes, including over the Internet, an advertisement in good faith, without knowledge of its false, deceptive, or misleading character.

Added Stats 1941 ch 63 § 1. Amended Stats 1951 ch 627 § 1; Stats 1998 ch 599 § 3 (SB 597).

#### **§ 17503. [No section of this number.]**

#### **§ 17504. Advertisement of price of goods or services sold in multiple units**

(a) Any person, partnership, corporation, firm, joint stock company, association, or organization engaged in business in this state as a retail seller who sells any consumer good or service which is sold only in multiple units and which is advertised by price shall advertise those goods or services at the price of the minimum multiple unit in which they are offered.

(b) Nothing contained in subdivision (a) shall prohibit a retail seller from advertising any consumer good or service for sale at a single unit price where the goods or

services are sold only in multiple units and not in single units as long as the advertisement also discloses, at least as prominently, the price of the minimum multiple unit in which they are offered.

(c) For purposes of subdivisions (a) and (b), “consumer good” means any article which is used or bought for use primarily for personal, family, or household purposes, but does not include any food item.

(d) For the purposes of subdivisions (a) and (b), “consumer service” means any service which is obtained for use primarily for personal, family, or household purposes.

(e) For purposes of subdivisions (a) and (b), “retail seller” means an individual, firm, partnership, corporation, joint stock company, association, organization, or other legal relationship which engages in the business of selling consumer goods or services to retail buyers.

Added Stats 1975 ch 1123 § 1. Amended Stats 1983 ch 64 § 1; Stats 1987 ch 439 § 1.

#### § 17505. Misrepresentation as to nature of business

No person shall state, in an advertisement of his goods, that he is a producer, manufacturer, processor, wholesaler, or importer, or that he owns or controls a factory or other source of supply of goods, when such is not the fact, and no person shall in any other manner misrepresent the character, extent, volume, or type of his business.

Added Stats 1963 ch 1733 § 1.

#### § 17505.2. Requirements for representing oneself as recreation therapist; Civil action for violation

(a) It is unlawful for a person to represent himself or herself as a recreation therapist, to represent the services he or she performs as recreation therapy, or to use terms set forth in subdivision (c) in connection with his or her services, name, or place of business, unless he or she meets all of the following requirements:

(1) Graduation from an accredited college or university with a minimum of a baccalaureate degree in recreation therapy or in recreation and leisure studies with a specialization in recreation therapy. Alternatively, a person who does not have one of the preceding degrees may qualify if he or she has a baccalaureate degree in a specialization acceptable for certification or eligible for certification by any accrediting body specified in paragraph (2).

(2) Current certification or eligibility for certification as a recreation therapist by the California Board of Recreation and Park Certification or by the National Council for Therapeutic Recreation Certification, Inc.

(b) No person shall represent himself or herself as a recreation therapist assistant, or represent the services he or she performs as being in any way related to recreation therapy, unless he or she at a minimum has current certification, or has eligibility for certification, by the California Board of Recreation and Park Certification or by the National Council for Therapeutic Recreation Certification, Inc., as a recreation therapist assistant.

(c) A person who does not meet the requirements of subdivision (a) or (b) may not use any of the following

words or abbreviations in connection with his or her services, name, or place of business:

- (1) Recreation therapist registered.
- (2) Recreation therapist certified.
- (3) Certified therapeutic recreation specialist.
- (4) Recreation therapist.
- (5) Recreation therapist assistant registered.
- (6) Certified therapeutic recreation assistant.
- (7) RTR.
- (8) RTC.
- (9) CTRS.
- (10) RT.
- (11) RTAR.
- (12) CTRA.

(d) For purposes of subdivision (c), the abbreviation RT shall not be construed to include rehabilitation therapist or respiratory therapist.

(e) Any person injured by a violation of this section may bring a civil action and may recover one thousand five hundred dollars (\$1,500) for the first violation and two thousand five hundred dollars (\$2,500) for each subsequent violation. This is the sole remedy for a violation of this section.

Added Stats 1997 ch 677 § 6 (SB 1347). Amended Stats 1998 ch 485 § 26 (AB 2803).

#### § 17506. “Person”

As used in this chapter, “person” includes any individual, partnership, firm, association, or corporation.

Added Stats 1970 ch 664 § 1.

#### § 17506.5. “Board within the Department of Consumer Affairs”; “Local consumer affairs agency”

As used in this chapter:

(a) “Board within the Department of Consumer Affairs” includes any commission, bureau, division, or other similarly constituted agency within the Department of Consumer Affairs.

(b) “Local consumer affairs agency” means and includes any city or county body which primarily provides consumer protection services.

Added Stats 1979 ch 897 § 4.

#### § 17507. Disclosure of price differentials respecting more than one article of merchandise or type of service within same class

It is unlawful for any person, firm, corporation or association to make an advertising claim or representation pertaining to more than one article of merchandise or type of service, within the same class of merchandise or service, if any price is set forth in such claim or representation does not clearly and conspicuously identify the article of merchandise or type of service to which it relates. Disclosure of the relationship between the price and particular article of merchandise or type of service by means of an asterisk or other symbol, and corresponding footnote, does not meet the requirement of clear and conspicuous identification when the particular article of merchandise or type of service is not represented pictorially.

Added Stats 1971 ch 682 § 1.

**§ 17508. Purportedly fact-based or brand-comparison advertisements**

(a) It shall be unlawful for any person doing business in California and advertising to consumers in California to make any false or misleading advertising claim, including claims that (1) purport to be based on factual, objective, or clinical evidence, (2) compare the product's effectiveness or safety to that of other brands or products, or (3) purport to be based on any fact.

(b) Upon written request of the Director of Consumer Affairs, the Attorney General, any city attorney, or any district attorney, any person doing business in California and in whose behalf advertising claims are made to consumers in California, including claims that (1) purport to be based on factual, objective, or clinical evidence, (2) compare the product's effectiveness or safety to that of other brands or products, or (3) purport to be based on any fact, shall provide to the department or official making the request evidence of the facts on which the advertising claims are based. The request shall be made within one year of the last day on which the advertising claims were made.

Any city attorney or district attorney who makes a request pursuant to this subdivision shall give prior notice of the request to the Attorney General.

(c) The Director of Consumer Affairs, Attorney General, any city attorney, or any district attorney may, upon failure of an advertiser to respond by adequately substantiating the claim within a reasonable time, or if the Director of Consumer Affairs, Attorney General, city attorney, or district attorney shall have reason to believe that the advertising claim is false or misleading, do either or both of the following:

(1) Seek an immediate termination or modification of the claim by the person in accordance with Section 17535.

(2) Disseminate information, taking due care to protect legitimate trade secrets, concerning the veracity of the claims or why the claims are misleading to the consumers of this state.

(d) The relief provided for in subdivision (c) is in addition to any other relief that may be sought for a violation of this chapter. Section 17534 shall not apply to violations of this section.

(e) Nothing in this section shall be construed to hold any newspaper publisher or radio or television broadcaster liable for publishing or broadcasting any advertising claims referred to in subdivision (a), unless the publisher or broadcaster is the person making the claims.

(f) The plaintiff shall have the burden of proof in establishing any violation of this section.

(g) If an advertisement is in violation of subdivision (a) and Section 17500, the court shall not impose a separate civil penalty pursuant to Section 17536 for the violation of subdivision (a) and the violation of Section 17500 but shall impose a civil penalty for the violation of either subdivision (a) or Section 17500.

Added Stats 1972 ch 1417 § 1. Amended Stats 1974 ch 23 § 1; Stats 1976 ch 1002 § 1; Stats 1989 ch 947 § 1; Stats 2006 ch 538 § 24 (SB 1852), effective January 1, 2007.

**§ 17509. Advertisements soliciting purchase of product conditioned on purchase of different product; Price disclosure; Good faith exemption for publishers**

(a) Any advertisement, including any advertisement over the Internet, soliciting the purchase or lease of a

product or service, or any combination thereof, that requires, as a condition of sale, the purchase or lease of a different product or service, or any combination thereof, shall conspicuously disclose in the advertisement the price of all those products or services. This requirement shall not in any way affect the provisions of Sections 16726 and 16727, with respect to unlawful buying arrangements.

(b) Subdivision (a) does not apply to any of the following:

(1) Contractual plans or arrangements complying with this paragraph under which the seller periodically provides the consumer with a form or announcement card which the consumer may use to instruct the seller not to ship the offered merchandise. Any instructions not to ship merchandise included on the form or card shall be printed in type as large as all other instructions and terms stated on the form or card. The form or card shall specify a date by which it shall be mailed by the consumer (the "mailing date") or received by the seller (the "return date") to prevent shipment of the offered merchandise. The seller shall mail the form or card either at least 25 days prior to the return date or at least 20 days prior to the mailing date, or provide a mailing date of at least 10 days after receipt by the consumer, except that whichever system the seller chooses for mailing the form or card, shall be calculated to afford the consumer at least 10 days in which to mail his or her form or card. The form or card shall be preaddressed to the seller so that it may serve as a postal reply card or, alternatively, the form or card shall be accompanied by a return envelope addressed to seller. Upon the membership contract or application form or on the same page and immediately adjacent to the contract or form, and in clear and conspicuous language, there shall be disclosed the material terms of the plan or arrangement including all of the following:

(A) That aspect of the plan under which the subscriber shall notify the seller, in the manner provided for by the seller, if the seller does not wish to purchase or receive the selection.

(B) Any obligation assumed by the subscriber to purchase a minimum quantity of merchandise.

(C) The right of a contract-complete subscriber to cancel his or her membership at any time.

(D) Whether billing charges will include an amount for postage and handling.

(2) Other contractual plans or arrangements not covered under subdivision (a), such as continuity plans, subscription arrangements, standing order arrangements, supplements, and series arrangements under which the seller periodically ships merchandise to a consumer who has consented in advance to receive that merchandise on a periodic basis.

(c) This section shall not apply to the publisher of any newspaper, periodical, or other publication, or any radio or television broadcaster, or the owner or operator of any cable, satellite, or other medium of communication who broadcasts or publishes, including over the Internet, an advertisement or offer in good faith, without knowledge of its violation of subdivision (a).

Added Stats 1984 ch 643 § 1. Amended Stats 1998 ch 599 § 4 (SB 597).



## ARTICLE 2

### Particular Offenses

#### Section

- 17533.6. Use of term, symbol, or content indicating governmental connection; Exception in the case of endorsement; Solicitation indicating governmental connection; Violation; Remedies
- 17533.7. Use of words "Made in U.S.A." or similar words
17534. Punishment for violation
- 17534.5. Remedies or penalties cumulative
17535. Obtaining injunctive relief
- 17535.5. Penalty for violating injunction; Proceedings; Disposition of proceeds
17536. Penalty for violations of chapter; Proceedings; Disposition of proceeds
- 17536.5. Notice of issue in action before appellate court
17537. Conditioning prize-winning on purchase or rental
- 17537.1. Offering prize or gift as inducement to visit location or attend sales presentation; Required disclosures
- 17537.2. What constitutes deceptive and unfair trade practices with respect to inducement to visit location or attend sales presentation
- 17537.4. Civil action for making prohibited offers
- 17537.5. False statements relating to energy conservation products or services
- 17537.7. Unlawful use of specified terms to refer to dealer's cost for motor vehicle
- 17537.11. Misleading coupon

**§ 17533.6. Use of term, symbol, or content indicating governmental connection; Exception in the case of endorsement; Solicitation indicating governmental connection; Violation; Remedies**

(a) Except as described in subdivisions (b) and (c), it is unlawful for any person, firm, corporation, or association that is a nongovernmental entity to use a seal, emblem, insignia, trade or brand name, or any other term, symbol, or content that reasonably could be interpreted or construed as implying any federal, state, or local government, military veteran entity, or military or veteran service organization connection, approval, or endorsement of any product or service, including, but not limited to, any financial product, goods, or services, by any means, including, but not limited to, a mailing, electronic message, Internet Web site, periodical, or television commercial disseminated in this state, unless the nongovernmental entity has an expressed connection with, or the approval or endorsement of, a federal, state, or local government, military veteran entity, or military or veteran service organization.

(b) Notwithstanding subdivision (a) and if permitted by other provisions of law, any person, firm, corporation, or association that is a nongovernmental entity may advertise or promote any event, presentation, seminar, workshop, or other public gathering using a seal, emblem, insignia, trade or brand name, or any other term, symbol, or content as described in subdivision (a), if the person, firm, corporation, or association that is a nongovernmental entity has an expressed connection with, or the approval or endorsement of, a federal, state, or local government, military veteran entity, or military or veteran service organization.

(c) Notwithstanding subdivision (a), any person, firm, corporation, or association that is a nongovernmental entity may solicit information, solicit the purchase of or payment for a product or service, or solicit the contribution of funds or membership fees, by any means, including, but not limited to, a mailing, electronic mes-

sage, Internet Web site, periodical, or television commercial disseminated in this state, using a seal, emblem, insignia, trade or brand name, or any other term, symbol, or content as described in subdivision (a), if the person, firm, corporation, or association that is a nongovernmental entity meets the requirements of paragraph (1) or (2) as follows:

(1) The nongovernmental entity has an expressed connection with, or the approval or endorsement of, a federal, state, or local government entity, if permitted by other provisions of law.

(2)(A) The solicitation meets all of the following requirements:

(i) The solicitation conspicuously displays the following disclosure on the front and back of every page of the solicitation:

"THIS PRODUCT OR SERVICE HAS NOT BEEN APPROVED OR ENDORSED BY ANY GOVERNMENTAL AGENCY, AND THIS OFFER IS NOT BEING MADE BY AN AGENCY OF THE GOVERNMENT."

(ii) In the case of a mailed solicitation, the front of the envelope, outside cover, or wrapper in which the matter is mailed conspicuously displays the following disclosure:

"THIS IS NOT A GOVERNMENT DOCUMENT."

(iii) If permitted by other provisions of law, in the case of a television commercial disseminated in this state, the solicitation conspicuously displays the following disclosure at the top of the television screen for the entire duration of the television commercial:

"THIS PRODUCT OR SERVICE HAS NOT BEEN APPROVED OR ENDORSED BY ANY GOVERNMENTAL AGENCY, AND THIS OFFER IS NOT BEING MADE BY AN AGENCY OF THE GOVERNMENT."

(iv) The disclosure in clause (i) shall be displayed conspicuously, as provided in subdivision (f), and immediately below each portion of the solicitation that reasonably could be construed to specify an amount due and payable by the recipient. The disclosure in clause (ii) shall be displayed conspicuously, as provided in subdivision (f), and immediately below the area of the envelope, outside cover, or wrapper that is used for a return address. The disclosure in clause (iii) shall be displayed conspicuously, as provided in subdivision (f), and at the top of the television screen. The disclosures in clauses (i), (ii), and (iii) shall not be preceded, followed, or surrounded by symbols, terms, or other content that result in the disclosures not being conspicuous or that introduce, modify, qualify, or explain the text of those disclosures.

(v) The solicitation does not use a title or trade or brand name that reasonably could be interpreted or construed as implying any federal, state, or local government connection, approval, or endorsement, including, but not limited to, use of the term "agency," "administrative," "assessor," "board," "bureau," "collector," "commission," "committee," "department," "division," "recorder," "unit," "federal," "state," "county," "city," or "municipal," or the name or division of any government agency.

(vi) The solicitation does not specify a date or time period when payment to the soliciting nongovernmental person, firm, corporation, or association is due, including, but not limited to, use of the terms "due date," "due now," "remit by," "remit immediately," "payment due,"

“pay now,” “pay immediately,” or “pay no later than,” unless the solicitation displays, in the same sentence as the date or time period specified, how the information being solicited will be used, a description of the product or service that is to be provided and to what government agency it shall be rendered, or how the solicited funds or membership fees will be used, as applicable.

(vii) The solicitation does not state or imply that payment to any person, firm, corporation, or association that is not a government entity is mandatory or required by law, or state or imply that penalties, fines, or consequences will occur if payment is not made to the soliciting nongovernmental person, firm, corporation, or association.

(B) Subparagraph (A) is not applicable to seals, emblems, insignia, trade or brand name, or any other term, symbol, or content of the United States Department of Veterans Affairs, the Department of Veterans Affairs, the federal and state military, military veteran entities, and military or veteran service organizations.

(d) Notwithstanding Section 17534, any violation of this section is a misdemeanor punishable by imprisonment in a county jail not exceeding six months, or by a fine not exceeding two thousand five hundred dollars (\$2,500), or by both that fine and imprisonment.

(e) Any person who is harmed as a result of a violation of this section shall be entitled to recover, in addition to any other available remedies, damages in an amount equal to three times the amount solicited.

(f) For purposes of this section, “conspicuous” or “conspicuously” means displayed apart from other print on the page, envelope, outside cover, or wrapper and in not less than 12-point boldface font type in capital letters that is at least 2-point boldface font type sizes larger than the next largest print on the page, envelope, outside cover, or wrapper and in contrasting type, layout, font, or color in a manner that clearly calls attention to the language.

Added Stats 1993 ch 348 § 1 (AB 532). Amended Stats 1997 ch 249 § 1 (AB 1178); Stats 2002 ch 319 § 1 (SB 1240); Stats 2008 ch 256 § 1 (AB 2919), effective January 1, 2009; Stats 2009 ch 140 § 19 (AB 1164), effective January 1, 2010; Stats 2011 ch 269 § 1 (AB 75), effective January 1, 2012; Stats 2013 ch 695 § 1 (SB 272), effective January 1, 2014.

**§ 17533.7. Use of words “Made in U.S.A.” or similar words**

It is unlawful for any person, firm, corporation or association to sell or offer for sale in this State any merchandise on which merchandise or on its container there appears the words “Made in U.S.A.,” “Made in America,” “U.S.A.,” or similar words when the merchandise or any article, unit, or part thereof, has been entirely or substantially made, manufactured, or produced outside of the United States.

Added Stats 1961 ch 676 § 1.

**§ 17534. Punishment for violation**

Any person, firm, corporation, partnership or association or any employee or agent thereof who violates this chapter is guilty of a misdemeanor.

Added Stats 1941 ch 63 § 1.

**§ 17534.5. Remedies or penalties cumulative**

Unless otherwise expressly provided, the remedies or penalties provided by this chapter are cumulative to

each other and to the remedies or penalties available under all other laws of this state.

Added Stats 1973 ch 393 § 1.

**§ 17535. Obtaining injunctive relief**

Any person, corporation, firm, partnership, joint stock company, or any other association or organization which violates or proposes to violate this chapter may be enjoined by any court of competent jurisdiction. The court may make such orders or judgments, including the appointment of a receiver, as may be necessary to prevent the use or employment by any person, corporation, firm, partnership, joint stock company, or any other association or organization of any practices which violate this chapter, or which may be necessary to restore to any person in interest any money or property, real or personal, which may have been acquired by means of any practice in this chapter declared to be unlawful.

Actions for injunction under this section may be prosecuted by the Attorney General or any district attorney, county counsel, city attorney, or city prosecutor in this state in the name of the people of the State of California upon their own complaint or upon the complaint of any board, officer, person, corporation or association or by any person who has suffered injury in fact and has lost money or property as a result of a violation of this chapter. Any person may pursue representative claims or relief on behalf of others only if the claimant meets the standing requirements of this section and complies with Section 382 of the Code of Civil Procedure, but these limitations do not apply to claims brought under this chapter by the Attorney General, or any district attorney, county counsel, city attorney, or city prosecutor in this state.

Added Stats 1941 ch 63 § 1. Amended Stats 1972 ch 244 § 1, ch 711 § 3; amendment approved by voters, Prop. 64 § 5, effective November 3, 2004.

**§ 17535.5. Penalty for violating injunction; Proceedings; Disposition of proceeds**

(a) Any person who intentionally violates any injunction issued pursuant to Section 17535 shall be liable for a civil penalty not to exceed six thousand dollars (\$6,000) for each violation. Where the conduct constituting a violation is of a continuing nature, each day of such conduct is a separate and distinct violation. In determining the amount of the civil penalty, the court shall consider all relevant circumstances, including, but not limited to, the extent of harm caused by the conduct constituting a violation, the nature and persistence of such conduct, the length of time over which the conduct occurred, the assets, liabilities and net worth of the person, whether corporate or individual, and any corrective action taken by the defendant.

(b) The civil penalty prescribed by this section shall be assessed and recovered in a civil action brought in any county in which the violation occurs or where the injunction was issued in the name of the people of the State of California by the Attorney General or by any district attorney, county counsel, or city attorney in any court of competent jurisdiction within his jurisdiction without regard to the county from which the original injunction was issued. An action brought pursuant to this section to recover such civil penalties shall take special precedence

over all civil matters on the calendar of the court except those matters to which equal precedence on the calendar is granted by law.

(c) If such an action is brought by the Attorney General, one-half of the penalty collected pursuant to this section shall be paid to the treasurer of the county in which the judgment was entered, and one-half to the State Treasurer. If brought by a district attorney or county counsel, the entire amount of the penalty collected shall be paid to the treasurer of the county in which the judgment is entered. If brought by a city attorney or city prosecutor, one-half of the penalty shall be paid to the treasurer of the county in which the judgment was entered and one-half to the city.

(d) If the action is brought at the request of a board within the Department of Consumer Affairs or a local consumer affairs agency, the court shall determine the reasonable expenses incurred by the board or local agency in the investigation and prosecution of the action.

Before any penalty collected is paid out pursuant to subdivision (c), the amount of such reasonable expenses incurred by the board shall be paid to the State Treasurer for deposit in the special fund of the board described in Section 205. If the board has no such special fund, the moneys shall be paid to the State Treasurer. The amount of such reasonable expenses incurred by a local consumer affairs agency shall be paid to the general fund of the municipality or county which funds the local agency.

Added Stats 1973 ch 1042 § 1. Amended Stats 1974 ch 712 § 1; Stats 1979 ch 897 § 5.

#### § 17536. Penalty for violations of chapter; Proceedings; Disposition of proceeds

(a) Any person who violates any provision of this chapter shall be liable for a civil penalty not to exceed two thousand five hundred dollars (\$2,500) for each violation, which shall be assessed and recovered in a civil action brought in the name of the people of the State of California by the Attorney General or by any district attorney, county counsel, or city attorney in any court of competent jurisdiction.

(b) The court shall impose a civil penalty for each violation of this chapter. In assessing the amount of the civil penalty, the court shall consider any one or more of the relevant circumstances presented by any of the parties to the case, including, but not limited to, the following: the nature and seriousness of the misconduct, the number of violations, the persistence of the misconduct, the length of time over which the misconduct occurred, the willfulness of the defendant's misconduct, and the defendant's assets, liabilities, and net worth.

(c) If the action is brought by the Attorney General, one-half of the penalty collected shall be paid to the treasurer of the county in which the judgment was entered, and one-half to the State Treasurer.

If brought by a district attorney or county counsel, the entire amount of penalty collected shall be paid to the treasurer of the county in which the judgment was entered. If brought by a city attorney or city prosecutor, one-half of the penalty shall be paid to the treasurer of the county and one-half to the city. The aforementioned funds shall be for the exclusive use by the Attorney

General, district attorney, county counsel, and city attorney for the enforcement of consumer protection laws.

(d) If the action is brought at the request of a board within the Department of Consumer Affairs or a local consumer affairs agency, the court shall determine the reasonable expenses incurred by the board or local agency in the investigation and prosecution of the action.

Before any penalty collected is paid out pursuant to subdivision (c), the amount of such reasonable expenses incurred by the board shall be paid to the State Treasurer for deposit in the special fund of the board described in Section 205. If the board has no such special fund the moneys shall be paid to the State Treasurer. The amount of such reasonable expenses incurred by a local consumer affairs agency shall be paid to the general fund of the municipality which funds the local agency.

(e) As applied to the penalties for acts in violation of Section 17530, the remedies provided by this section and Section 17534 are mutually exclusive.

Added Stats 1965 ch 827 § 1. Amended Stats 1972 ch 711 § 2, ch 1105 § 2; Stats 1973 ch 752 § 1; Stats 1974 ch 875 § 1; Stats 1979 ch 897 § 6; Stats 1992 ch 430 § 5 (SB 1586); amendment approved by voters, Prop. 64 § 6, effective November 3, 2004.

#### § 17536.5. Notice of issue in action before appellate court

If a violation of this chapter is alleged or the application or construction of this chapter is in issue in any proceeding in the Supreme Court of California, a state court of appeal, or the appellate division of a superior court, each person filing any brief or petition with the court in that proceeding shall serve, within three days of filing with the court, a copy of that brief or petition on the Attorney General, directed to the attention of the Consumer Law Section at a service address designated on the Attorney General's official Web site for service of papers under this section or, if no service address is designated, at the Attorney General's office in San Francisco, California, and on the district attorney of the county in which the lower court action or proceeding was originally filed. Upon the Attorney General's or district attorney's request, each person who has filed any other document, including all or a portion of the appellate record, with the court in addition to a brief or petition shall provide a copy of that document without charge to the Attorney General or the district attorney within five days of the request. The time for service may be extended by the Chief Justice or presiding justice or judge for good cause shown. No judgment or relief, temporary or permanent, shall be granted or opinion issued until proof of service of the petition or brief on the Attorney General and district attorney is filed with the court.

Added Stats 1992 ch 385 § 3 (SB 1911). Amended Stats 1998 ch 931 § 10 (SB 2139), effective September 28, 1998; Stats 2004 ch 529 § 5 (AB 1711).

#### § 17537. Conditioning prize-winning on purchase or rental

(a) It is unlawful for any person to use the term "prize" or "gift" or other similar term in any manner that would be untrue or misleading, including, but not limited to, the manner made unlawful in subdivision (b) or (c).

(b) It is unlawful to notify any person by any means, as a part of an advertising plan or program, that he or

she has won a prize and that as a condition of receiving such prize he or she must pay any money or purchase or rent any goods or services.

(c) It is unlawful to notify any person by any means that he or she will receive a gift and that as a condition of receiving the gift he or she must pay any money, or purchase or lease (including rent) any goods or services, if any one or more of the following conditions exist:

(1) The shipping charge, depending on the method of shipping used, exceeds (A) the average cost of postage or the average charge of a delivery service in the business of delivering goods of like size, weight, and kind for shippers other than the offeror of the gift for the geographic area in which the gift is being distributed, or (B) the exact amount for shipping paid to an independent fulfillment house or an independent supplier, either of which is in the business of shipping goods for shippers other than the offeror of the gift.

(2) The handling charge (A) is not reasonable, or (B) exceeds the actual cost of handling, or (C) exceeds the greater of three dollars (\$3) in any transaction or 80 percent of the actual cost of the gift item to the offeror or its agent, or (D) in the case of a general merchandise retailer, exceeds the actual amount for handling paid to an independent fulfillment house or supplier, either of which is in the business of handling goods for businesses other than the offeror of the gift.

(3) Any goods or services which must be purchased or leased by the offeree of the gift in order to obtain the gift could have been purchased through the same marketing channel in which the gift was offered for a lower price without the gift items at or proximate to the time the gift was offered.

(4) The majority of the gift offeror's sales or leases within the preceding year, through the marketing channel in which the gift is offered or through in-person sales at retail outlets, of the type of goods or services which must be purchased or leased in order to obtain the gift item was made in conjunction with the offer of a gift.

This paragraph does not apply to a gift offer made by a general merchandise retailer in conjunction with the sale or lease through mail order of goods or services (excluding catalog sales) if (A) the goods or services are of a type unlike any other type of goods or services sold or leased by the general merchandise retailer at any time during the period beginning six months before and continuing until six months after the gift offer, (B) the gift offer does not extend for a period of more than two months, and (C) the gift offer is not untrue or misleading in any manner.

(5) The gift offeror represents that the offeree has been specially selected in any manner unless (A) the representation is true and (B) the offeree made a purchase from the gift offeror within the six-month period before the gift offer was made or has a credit card issued by, or a retail installment account with, the gift offeror.

(d) The following definitions apply to this section:

(1) "Marketing channel" means a method of retail distribution, including, but not limited to, catalog sales, mail order, telephone sales, and in-person sales at retail outlets.

(2) "General merchandise retailer" means any person or entity regardless of the form of organization that has continuously offered for sale or lease more than 100

different types of goods or services to the public in California throughout a period exceeding five years.

(e) Each violation of the provisions of this section is a misdemeanor punishable by imprisonment in the county jail not exceeding six months, or by a fine not exceeding two thousand five hundred dollars (\$2,500), or by both.

Added Stats 1970 ch 1119 § 1. Amended Stats 1971 ch 709 § 1; Stats 1976 ch 1125 § 6; Stats 1984 ch 101 § 1; Stats 1986 ch 812 § 1, effective September 15, 1986.

**§ 17537.1. Offering prize or gift as inducement to visit location or attend sales presentation; Required disclosures**

(a) It is unlawful for any person, or an employee, agent or independent contractor employed or authorized by that person, by any means, as part of an advertising plan or program, to offer any incentive as an inducement to the recipient to visit a location, attend a sales presentation, or contact a sales agent in person, by telephone or by mail, unless the offer clearly and conspicuously discloses in writing, in readily understandable language, all of the information required in paragraphs (1) and (2). If the offer is not initially made in writing, the required disclosures shall be received by the recipient in writing prior to any scheduled visit to a location, sales presentation, or contact with a sales agent. For purposes of this section, the term "incentive" means any item or service of value, including, but not limited to, any prize, gift, money, or other tangible property.

(1) The following disclosures shall appear on the front (or first) page of the offer:

(A) The name and street address of the owner of the real or personal property or the provider of the services which are the subject of the visit, sales presentation, or contact with a sales agent. If the offer is made by an agent or independent contractor employed or authorized by the owner or provider, or is made under a name other than the true name of the owner or provider, the name of the owner or provider shall be more prominently and conspicuously displayed than the name of the agent, independent contractor, or other name.

(B) A general description of the business of the owner or provider identified pursuant to subparagraph (A), and the purpose of any requested visit, sales presentation, or contact with a sales agent, which shall include a general description of the real or personal property or services which are the subject of the sales presentation and a clear statement, if applicable, that there will be a sales presentation and the approximate duration of the visit and sales presentation.

(C) If the recipient is not assured of receiving any particular incentive, a statement of the odds of receiving each incentive offered or, in the alternative, a clear statement describing the location in the offer where the odds can be found. The odds shall be stated in whole Arabic numbers in a format such as: "1 chance in 100,000" or "1:100,000." The odds and, where applicable, the alternative statement describing their location, shall be printed in a type size that is at least equal to that used for the standard text on the front (or first) page of the offer.

(D) A clear statement, if applicable, that the offer is subject to specific restrictions, qualifications, and conditions and a statement describing the location in the offer

where the restrictions, qualifications, and conditions may be found. Both statements shall be printed in a type size that is at least equal to that used for the standard text on the front (or first) page of the offer.

(2) The following disclosures shall appear in the offer, but need not appear on the front (or first) page of the offer:

(A) Unless the odds are disclosed on the front (or first) page of the offer, a statement of the odds of receiving each incentive offered, printed in the size and format set forth in subparagraph (C) of paragraph (1).

(B) All restrictions, qualifications, and other conditions which must be satisfied before the recipient is entitled to receive the incentive, including but not limited to:

(i) Any deadline by which the recipient must visit the location, attend the sales presentation, or contact the sales agent in order to receive an incentive.

(ii) Any other conditions, such as a minimum age qualification, a financial qualification, or a requirement that if the recipient is married both husband and wife must be present in order to receive the incentive. Any financial qualifications shall be stated with a specificity sufficient to enable the recipient to reasonably determine his or her eligibility.

(C) A statement that the owner or provider identified pursuant to subparagraph (A) of paragraph (1) reserves the right to provide a raincheck, or a substitute or like incentive, if those rights are reserved.

(D) A statement that a recipient who receives an offered incentive may request and will receive evidence showing that the incentive provided matches the incentive randomly or otherwise selected for distribution to that recipient.

(E) All other rules, terms, and conditions of the offer, plan, or program.

(b) It is unlawful for any person making an offer subject to subdivision (a), or any employee, agent, or independent contractor employed or authorized by that person, to offer any incentive when the person knows or has reason to know that the offered item will not be available in a sufficient quantity based upon the reasonably anticipated response to the offer.

(c) It is unlawful for any person making an offer subject to subdivision (a), or any employee, agent, or independent contractor employed or authorized by that person, to fail to provide any offered incentive which any recipient who has responded to the offer in the manner specified therein, who has performed the requirements disclosed therein, and who has met the qualifications described therein, is entitled to receive, unless the offered incentive is not reasonably available and the offer discloses the reservation of a right to provide a raincheck, or a like or substitute incentive, if the offered incentive is unavailable.

(d) If the person making an offer subject to subdivision (a) is unable to provide an offered incentive because of limitations of supply, quantity, or quality that were not reasonably foreseeable or controllable by the person making the offer, the person making the offer shall inform the recipient of the recipient's right to receive a raincheck for the incentive offered, unless the person making the offer knows or has reasonable basis for knowing that the incentive will not be reasonably avail-

able and shall inform the recipient of the recipient's right to at least one of the following additional options:

(1) The person making the offer will provide a like incentive of equivalent or greater retail value or a raincheck therefor.

(2) The person making the offer will provide a substitute incentive of equivalent or greater retail value.

(3) The person making the offer will provide a raincheck for the like or substitute incentive.

(e) If a raincheck is provided, the person making an offer subject to subdivision (a) shall, within a reasonable time, and in no event later than 80 days, deliver the agreed incentive to the recipient's address without additional cost or obligation to the recipient, unless the incentive for which the raincheck is provided remains unavailable because of limitations of supply, quantity, or quality not reasonably foreseeable or controllable by the person making the offer. In that case, the person making the offer shall, not later than 30 days after the expiration of the 80 days, deliver a like incentive of equal or greater retail value or, if an incentive is not reasonably available to the person making the offer, a substitute incentive of equal or greater retail value.

(f) Upon the request of a recipient who has received or claims a right to receive any offered incentive, the person making an offer subject to subdivision (a) shall furnish to the person sufficient evidence showing that the incentive provided matches the incentive randomly or otherwise selected for distribution to that recipient.

(g) It is unlawful for any person making an offer subject to subdivision (a), or any employee, agent, or independent contractor employed or authorized by that person, to:

(1) Use any printing styles, graphics, layouts, text, colors, or formats on envelopes or on the offer which, implies, creates an appearance, or would lead a reasonable person to believe, that the offer originates from or is issued by or on behalf of a government or public agency, public utility, public organization, insurance company, credit reporting agency, bill collecting company or law firm, unless the same is true.

(2) Misrepresent the size, quantity, identity, value, or qualities of any incentive.

(3) Misrepresent in any manner the odds of receiving any particular incentive.

(4) Represent directly or by implication that the number of participants has been significantly limited or that any person has been selected to receive a particular incentive unless that is the fact.

(5) Label any offer a notice of termination or notice of cancellation.

(6) Misrepresent, in any manner, the offer, plan, program or the affiliation, connection, association, or contractual relationship between the person making the offer and the owner or provider, if they are not the same.

(h) If the major incentives are awarded or given at random, by the assignment of a number to the incentives, that number shall be actually assigned by the party contractually responsible for doing so. The person making an offer subject to subdivision (a) hereof, or the agent, employee, or independent contractor employed or authorized by that person, if any, shall maintain, for a period of one year after the date the offer is made, the records that show that the winning numbers or opportu-

nity to receive the major incentives have been deposited in the mail or otherwise made available to recipients in accordance with the odds statement provided pursuant to subparagraph (C) of paragraph (1) of subdivision (a) hereof. The records shall be made available to the Attorney General within 30 days after written request therefor. Postal receipt records, affidavits of mailing, or a list of winners or recipients of the major incentives shall be deemed to satisfy the requirements of this section.

Added Stats 1984 ch 101 § 2. Amended Stats 1990 ch 1529 § 1 (SB 2203).

**§ 17537.2. What constitutes deceptive and unfair trade practices with respect to inducement to visit location or attend sales presentation**

The following, when used as part of an advertising plan or program defined in Section 17537.1, are deceptive and constitute unfair trade practices:

(a) When, in order to utilize the incentive, the recipient is requested to pay any money to any person or entity named or referred to in the offer, or to purchase, rent, or otherwise pay that person or entity for any product or service including a deposit, whether returnable or not, whether payment is for an item, a service, shipping, handling, insurance or payment for anything.

Notwithstanding the preceding paragraph, when the offered incentive is a certificate or coupon redeemable for transportation, accommodations, recreation, vacation, entertainment, or like services, the offer may place a condition on the use of the incentive which requires the recipient to pay directly to the transportation company, the accommodation, recreation, vacation or entertainment facility, or similar direct provider of like services, a refundable deposit, not to exceed fifty dollars (\$50), to reserve space availability or admission, only if the deposit shall be returned in United States dollars immediately upon the recipient's arrival at the location of the provider to whom the recipient paid the deposit. If the incentive is such a certificate or coupon, and if government-imposed taxes directly related to the service being provided are not included in the incentive, the offer itself, in close proximity to the description of the incentive which is evidenced by the certificate or coupon, shall disclose those government-imposed taxes which will be the recipient's responsibility and the approximate dollar amount of those taxes. A deposit from the recipient may be collected to cover the cost of those government-imposed taxes.

(b) Stating or implying in the offer that the recipient is one of a selected group to receive a particular incentive or one or more of a group of incentives, without clearly and conspicuously disclosing in close proximity to the statement or implied statement of selection the total number of persons in that select group or the odds of receiving the incentive or incentives. Statements of selection which require such disclosure include such phrases as "you are a finalist," "we are sending this to a limited number of people," "either you or another named person has won the major prize," "if you do not respond, your incentive will be given to someone else."

(c) Stating or implying in the offer that the recipient is likely to receive one or more of the offered incentives because other named people have already received other named incentives, unless the offer clearly and conspicu-

ously discloses in close proximity to the statement the recipient's odds of receiving the identified incentive.

(d) When the solicitation states or implies that the recipient is likely to receive an incentive which has a normal retail price which is higher than that of another named incentive unless that statement is true. For purposes of this section, a list of incentives implies that the incentives are in descending or ascending order of value unless the solicitation clearly and conspicuously negates the implication in close proximity to the list.

(e) Describing an incentive or incentives in an untrue or misleading manner. Untrue or misleading descriptions include those which imply that the incentive being offered is of greater fair market value or of a different kind or nature than a recipient would be led to believe from a reasonable reading of the offer, or which lists the recipient's name in close proximity to a specific incentive unless the offer clearly and conspicuously discloses immediately next to or immediately under or above the recipient's name the recipient's odds of receiving the specific incentive.

(f) Subdivision (a) shall not apply to an incentive constituting an opportunity to stay at a hotel or other resort accommodations at a discount from the standard rate for the hotel or resort accommodations, if all of the following conditions are met:

(1) The fee to utilize the incentive and the requirement, if any, to attend a sales presentation are clearly and conspicuously disclosed in close proximity to the description of the offered incentive.

(2) A statement appears in close proximity to the description of the offered incentive and in substantially the following form: The recipient is responsible for payment of any government-imposed taxes directly related to the service being provided and any personal expenses incurred when utilizing this offer.

(3) The accommodations to be occupied by the recipient of the incentive are within a 20-mile radius of the property on which the accommodations offered for sale are located or, if not within that radius, the accommodations offered for sale are managed and operated by the same person as, an affiliate (as defined in Section 150 of the Corporations Code) of, or a franchisee (as defined in Section 20002) of, the manager and operator of the accommodations to be occupied, and the manager and operator of the accommodations offered for sale or the manager and operator of the accommodations to be occupied is an issuer or subsidiary of an issuer that has a security listed on a national securities exchange or designated as a national market system security on an interdealer quotation system by the National Association of Securities Dealers, Inc. and the exchange or interdealer quotation system has been certified by rule or order of the Commissioner of Corporations under subdivision (o) of Section 25100 of the Corporations Code. A subsidiary of an issuer that qualifies under this paragraph does not itself qualify under this paragraph unless not less than 60 percent of the voting power of its shares is owned by the qualifying issuer or issuers.

(4) If the incentive is offered in conjunction with any additional incentive or incentives or as one or more of a group of incentives, the offer of such additional incentive or incentives shall comply with Section 17537.1 and the following:

(A) The additional incentive or incentives are typically and customarily included in a vacation package and may include, but not be limited to, transportation, dining, entertainment, or recreation.

(B) The fee and additional requirements, if any, to use the additional incentive or incentives are clearly and conspicuously disclosed in close proximity to the description of the offer of them.

Added Stats 1990 ch 1529 § 3 (SB 2203). Amended Stats 1991 ch 983 § 20 (SB 1195); Stats 1992 ch 179 § 1 (SB 1678); Stats 1994 ch 1123 § 1 (AB 918).

#### § 17537.4. Civil action for making prohibited offers

If the person making an offer subject to Section 17537 or to subdivision (a) of Section 17537.1, or any employee, agent, or independent contractor employed or authorized by that person, violates any provision of Section 17537, 17537.1, or 17537.2, the recipient of the offer who is damaged by the violation may bring a civil action against the person making the offer for, and may be awarded, treble damages. The court may award reasonable attorneys' fees to the prevailing party.

Added Stats 1989 ch 520 § 1, as B & P C § 17537.2. Amended and renumbered by Stats 1990 ch 1529 § 2 (SB 2230).

#### § 17537.5. False statements relating to energy conservation products or services

(a) It is unlawful for any person soliciting a sale or order for energy conservation products or services, including over the Internet, to do any of the following:

(1) Make false claims of affiliation or association with an electrical or gas corporation or municipally owned and operated electrical or gas utility or its energy conservation programs.

(2) Falsely represent that the purchase of an energy conservation service or the purchase or installation of an energy conservation product is required by law.

(3) Misrepresent the nature of the purchaser's obligation for the purchase price of the energy conservation products or services.

(4) Misrepresent the tax consequences of purchasing energy conservation products or services.

(b) Any person, firm, corporation, partnership or association, and any employee or agent thereof who violates this section (1) in the course of solicitation of a sale or order at a residence; (2) by telephone; or (3) by any other method or at any other location, including over the Internet, shall be liable for the damages provided by subdivision (c) of Section 17500.3, in addition to all other penalties provided by law.

Added Stats 1983 ch 243 § 1. Amended Stats 1998 ch 599 § 14 (SB 597).

#### § 17537.7. Unlawful use of specified terms to refer to dealer's cost for motor vehicle

Except as to communications described in paragraph (2) of subdivision (n) of Section 11713.1 of the Vehicle Code, it is unlawful for any person to use the terms "invoice," "dealer invoice," "wholesale price," or similar terms that refer to a dealer's cost for a motor vehicle in an advertisement for the sale or lease of a vehicle, or advertise that the selling price of a vehicle is above, below, or at either of the following:

(a) The manufacturer's or distributor's invoice or selling price to a dealer.

(b) A dealer's cost.

Added Stats 1995 ch 585 § 1 (AB 192).

#### § 17537.11. Misleading coupon

(a) It is unlawful for any person to offer a coupon that is in any manner untrue or misleading.

(b) It is unlawful for any person to offer a coupon described as "free" or as a "gift," "prize," or other similar term if (1) the recipient of the coupon is required to pay money or buy any goods or services to obtain or use the coupon, and (2) the person offering the coupon or anyone honoring the coupon made the majority of his or her sales in the preceding year in connection with one or more "free," "gift," "prize," or similarly described coupons.

(c) For purposes of this section:

(1) "Coupon" includes any coupon, certificate, document, discount, or similar matter that purports to entitle the user of the coupon to obtain goods or services for free or for a special or reduced price.

(2) "Sale" includes lease or rent.

Added Stats 1999 ch 907 § 2 (AB 1231). Amended Stats 2000 ch 135 § 10 (AB 2539).

## ARTICLE 7.5

### Automotive Products

Section

17582. Bittering agent in engine coolant or antifreeze

#### § 17582. Bittering agent in engine coolant or antifreeze

(a) Any engine coolant or antifreeze sold in this state after January 1, 2004, that is manufactured after July 1, 2003, and that contains more than 10 percent ethylene glycol, shall include denatonium benzoate at a minimum of 30 parts per million as a bittering agent within the product so as to render it unpalatable. Another aversive agent may be used if it meets or exceeds the degree of aversion in test subjects obtained by utilizing the formulation of 30 parts per million of denatonium benzoate in antifreeze. Any manufacturer or packager of a product subject to this section shall maintain a record of the trade name, scientific name, and active ingredients of any bittering agent used pursuant to this chapter. Information and documentation maintained pursuant to this section shall be furnished to any member of the public upon request.

(b)(1) A manufacturer, distributor, recycler, or seller of an automotive product that is required to contain an aversive agent under this section is not liable to any person for any personal injury, death, or property damage that results from the inclusion of denatonium benzoate in ethylene glycol antifreeze.

(2) The limitation on liability provided by this subdivision is only applicable if denatonium benzoate is included in ethylene glycol antifreeze in concentrations mandated by this section.

(3) The limitation on liability provided by this subdivision does not apply if the personal injury, death, or property damage results from willful or wanton miscon-

duct by the manufacturer, distributor, recycler, or seller of the ethylene glycol antifreeze.

(c) This section shall not be construed to apply to any of the following:

(1) The sale of a motor vehicle that contains engine coolant or antifreeze.

(2) Wholesale containers of antifreeze containing 55 gallons or more of the antifreeze.

Added Stats 2002 ch 998 § 2 (AB 2474).



# CIVIL CODE

## DIVISION 3

### Obligations

#### PART 4

### Obligations Arising from Particular Transactions

#### TITLE 1.7

### Consumer Warranties

#### CHAPTER 1

### Consumer Warranty Protection

#### ARTICLE 1

### General Provisions

#### Section

1790. Title

1790.1. Enforceability of waiver

1790.2. Severability

1790.3. Construction in case of conflict with Commercial Code

1790.4. Cumulative remedies

#### § 1790. Title

This chapter may be cited as the “Song–Beverly Consumer Warranty Act.”

Added Stats 1970 ch 1333 § 1.

#### § 1790.1. Enforceability of waiver

Any waiver by the buyer of consumer goods of the provisions of this chapter, except as expressly provided in this chapter, shall be deemed contrary to public policy and shall be unenforceable and void.

Added Stats 1970 ch 1333 § 1.

#### § 1790.2. Severability

If any provision of this chapter or the application thereof to any person or circumstance is held unconstitutional, such invalidity shall not affect other provisions or applications of this chapter which can be given effect without the invalid provision or application, and to this end the provisions of this chapter are severable.

Added Stats 1970 ch 1333 § 1.

#### § 1790.3. Construction in case of conflict with Commercial Code

The provisions of this chapter shall not affect the rights and obligations of parties determined by reference to the Commercial Code except that, where the provisions of the Commercial Code conflict with the rights guaranteed to buyers of consumer goods under the provisions of this chapter, the provisions of this chapter shall prevail.

Added Stats 1970 ch 1333 § 1.

#### § 1790.4. Cumulative remedies

The remedies provided by this chapter are cumulative and shall not be construed as restricting any remedy that is otherwise available, and, in particular, shall not be construed to supplant the provisions of the Unfair Practices Act.

Added Stats 1971 ch 1523 § 1, operative January 1, 1972. Amended Stats 1976 ch 416 § 1.

### ARTICLE 2

### Definitions

#### Section

1791. Definitions

1791.1. “Implied warranty of merchantability”; “Implied warranty of fitness”

1791.2. “Express warranty”

1791.3. “As is”; “With all faults”

#### § 1791. Definitions

As used in this chapter:

(a) “Consumer goods” means any new product or part thereof that is used, bought, or leased for use primarily for personal, family, or household purposes, except for clothing and consumables. “Consumer goods” shall include new and used assistive devices sold at retail.

(b) “Buyer” or “retail buyer” means any individual who buys consumer goods from a person engaged in the business of manufacturing, distributing, or selling consumer goods at retail. As used in this subdivision, “person” means any individual, partnership, corporation, limited liability company, association, or other legal entity that engages in any of these businesses.

(c) “Clothing” means any wearing apparel, worn for any purpose, including under and outer garments, shoes, and accessories composed primarily of woven material, natural or synthetic yarn, fiber, or leather or similar fabric.

(d) “Consumables” means any product that is intended for consumption by individuals, or use by individuals for purposes of personal care or in the performance of services ordinarily rendered within the household, and that usually is consumed or expended in the course of consumption or use.

(e) “Distributor” means any individual, partnership, corporation, association, or other legal relationship that stands between the manufacturer and the retail seller in purchases, consignments, or contracts for sale of consumer goods.

(f) “Independent repair or service facility” or “independent service dealer” means any individual, partnership, corporation, association, or other legal entity, not an employee or subsidiary of a manufacturer or distributor, that engages in the business of servicing and repairing consumer goods.

(g) “Lease” means any contract for the lease or bailment for the use of consumer goods by an individual, for a term exceeding four months, primarily for personal, family, or household purposes, whether or not it is agreed that the lessee bears the risk of the consumer goods’ depreciation.

(h) “Lessee” means an individual who leases consumer goods under a lease.

(i) “Lessor” means a person who regularly leases consumer goods under a lease.

(j) “Manufacturer” means any individual, partnership, corporation, association, or other legal relationship that manufactures, assembles, or produces consumer goods.

(k) “Place of business” means, for the purposes of any retail seller that sells consumer goods by catalog or mail order, the distribution point for consumer goods.

(l) “Retail seller,” “seller,” or “retailer” means any individual, partnership, corporation, association, or other legal relationship that engages in the business of selling or leasing consumer goods to retail buyers.

(m) “Return to the retail seller” means, for the purposes of any retail seller that sells consumer goods by catalog or mail order, the retail seller’s place of business, as defined in subdivision (k).

(n) “Sale” means either of the following:

(1) The passing of title from the seller to the buyer for a price.

(2) A consignment for sale.

(o) “Service contract” means a contract in writing to perform, over a fixed period of time or for a specified duration, services relating to the maintenance or repair of a consumer product, except that this term does not include a policy of automobile insurance, as defined in Section 116 of the Insurance Code.

(p) “Assistive device” means any instrument, apparatus, or contrivance, including any component or part thereof or accessory thereto, that is used or intended to be used, to assist an individual with a disability in the mitigation or treatment of an injury or disease or to assist or affect or replace the structure or any function of the body of an individual with a disability, except that this term does not include prescriptive lenses and other ophthalmic goods unless they are sold or dispensed to a blind person, as defined in Section 19153 of the Welfare and Institutions Code and unless they are intended to assist the limited vision of the person so disabled.

(q) “Catalog or similar sale” means a sale in which neither the seller nor any employee or agent of the seller nor any person related to the seller nor any person with a financial interest in the sale participates in the diagnosis of the buyer’s condition or in the selection or fitting of the device.

(r) “Home appliance” means any refrigerator, freezer, range, microwave oven, washer, dryer, dishwasher, garbage disposal, trash compactor, or room air-conditioner normally used or sold for personal, family, or household purposes.

(s) “Home electronic product” means any television, radio, antenna rotator, audio or video recorder or playback equipment, video camera, video game, video monitor, computer equipment, telephone, telecommunications equipment, electronic alarm system, electronic appliance control system, or other kind of electronic

product, if it is normally used or sold for personal, family, or household purposes. The term includes any electronic accessory that is normally used or sold with a home electronic product for one of those purposes. The term excludes any single product with a wholesale price to the retail seller of less than fifty dollars (\$50).

(t) “Member of the Armed Forces” means a person on full-time active duty in the Army, Navy, Marine Corps, Air Force, National Guard, or Coast Guard. Full-time active duty shall also include active military service at a military service school designated by law or the Adjutant General of the Military Department concerned.

This section shall become operative on January 1, 2008.

Added Stats 1993 ch 1265 § 12.5 (SB 798), operative January 1, 1998. Amended Stats 1994 ch 1010 § 39.5 (SB 2053), operative January 1, 1998; Stats 1995 ch 461 § 2 (AB 40), operative January 1, 1998; Stats 1997 ch 401 § 63 (SB 780), operative January 1, 2003; Stats 2002 ch 405 § 62 (AB 2973); Stats 2007 ch 151 § 1 (SB 234), effective January 1, 2008.

### § 1791.1. “Implied warranty of merchantability”; “Implied warranty of fitness”

As used in this chapter:

(a) “Implied warranty of merchantability” or “implied warranty that goods are merchantable” means that the consumer goods meet each of the following:

(1) Pass without objection in the trade under the contract description.

(2) Are fit for the ordinary purposes for which such goods are used.

(3) Are adequately contained, packaged, and labeled.

(4) Conform to the promises or affirmations of fact made on the container or label.

(b) “Implied warranty of fitness” means (1) that when the retailer, distributor, or manufacturer has reason to know any particular purpose for which the consumer goods are required, and further, that the buyer is relying on the skill and judgment of the seller to select and furnish suitable goods, then there is an implied warranty that the goods shall be fit for such purpose and (2) that when there is a sale of an assistive device sold at retail in this state, then there is an implied warranty by the retailer that the device is specifically fit for the particular needs of the buyer.

(c) The duration of the implied warranty of merchantability and where present the implied warranty of fitness shall be coextensive in duration with an express warranty which accompanies the consumer goods, provided the duration of the express warranty is reasonable; but in no event shall such implied warranty have a duration of less than 60 days nor more than one year following the sale of new consumer goods to a retail buyer. Where no duration for an express warranty is stated with respect to consumer goods, or parts thereof, the duration of the implied warranty shall be the maximum period prescribed above.

(d) Any buyer of consumer goods injured by a breach of the implied warranty of merchantability and where applicable by a breach of the implied warranty of fitness has the remedies provided in Chapter 6 (commencing with Section 2601) and Chapter 7 (commencing with Section 2701) of Division 2 of the Commercial Code, and,

in any action brought under such provisions, Section 1794 of this chapter shall apply.

Added Stats 1970 ch 1333 § 1. Amended Stats 1971 ch 1523 § 3, operative January 1, 1972; Stats 1978 ch 991 § 2; Stats 1979 ch 1023 § 1.5.

### § 1791.2. “Express warranty”

(a) “Express warranty” means:

(1) A written statement arising out of a sale to the consumer of a consumer good pursuant to which the manufacturer, distributor, or retailer undertakes to preserve or maintain the utility or performance of the consumer good or provide compensation if there is a failure in utility or performance; or

(2) In the event of any sample or model, that the whole of the goods conforms to such sample or model.

(b) It is not necessary to the creation of an express warranty that formal words such as “warranty” or “guarantee” be used, but if such words are used then an express warranty is created. An affirmation merely of the value of the goods or a statement purporting to be merely an opinion or commendation of the goods does not create a warranty.

(c) Statements or representations such as expressions of general policy concerning customer satisfaction which are not subject to any limitation do not create an express warranty.

Added Stats 1970 ch 1333 § 1. Amended Stats 1978 ch 991 § 2.5.

### § 1791.3. “As is”; “With all faults”

As used in this chapter, a sale “as is” or “with all faults” means that the manufacturer, distributor, and retailer disclaim all implied warranties that would otherwise attach to the sale of consumer goods under the provisions of this chapter.

Added Stats 1970 ch 1333 § 1.

## ARTICLE 3 Sale Warranties

### Section

1792. Implied warranty of merchantability

1792.1. Manufacturer’s implied warranty of fitness for particular purpose

1792.2. Retailer’s or distributor’s implied warranty of fitness for particular purpose

1792.3. Waiver of implied warranties

1792.4. Disclaimer of implied warranty

1792.5. “As is” sales

1793. Express warranties

1793.1. Form of express warranties; Requirements on distribution of warranty or product registration car or form, or electronic online warranty or product registration forms

1793.2. Duties of manufacturer making express warranty

1793.22. Reasonable number of attempts to conform vehicle to warranties; Dispute resolution process; Transfer of vehicle

1793.23. Disclosures required of seller of returned vehicle; “Lemon Law Buyback”

1793.24. Warranty buyback notice

1793.25. Sales tax reimbursement to vehicle manufacturer after restitution under express warranty

1793.26. Restrictions on confidentiality clause, gag clause, or other similar clause associated with reacquisition of motor vehicle

1793.3. Failure to provide service facility in conjunction with express warranty

1793.4. Time to exercise option for service of item under express warranty

### Section

1793.5. Liability of manufacturer making express warranties for failure to maintain service facilities

1793.6. Manufacturer’s liability to independent serviceman performing services or incurring obligations on express warranties

1794. Buyer’s damages, penalties and fees

1794.1. Seller’s and serviceman’s damages

1794.4. Service contract in lieu of warranty

1794.41. Vehicle, home appliance, or home electronic product service contract; Requirements; Applicability; Conflicts with insurance provisions

1794.5. Alternative suggestions for repair of item under express warranty

1795. Liability of nonmanufacturer making express warranty

1795.1. Application of chapter to components of air conditioning system

1795.5. Obligations of distributors or sellers of used goods

1795.6. Tolling the warranty period

1795.7. Effect of tolling on manufacturer’s liability

### § 1792. Implied warranty of merchantability

Unless disclaimed in the manner prescribed by this chapter, every sale of consumer goods that are sold at retail in this state shall be accompanied by the manufacturer’s and the retail seller’s implied warranty that the goods are merchantable. The retail seller shall have a right of indemnity against the manufacturer in the amount of any liability under this section.

Added Stats 1970 ch 1333 § 1. Amended Stats 1971 ch 1523 § 4, operative January 1, 1972; Stats 1978 ch 991 § 3.

### § 1792.1. Manufacturer’s implied warranty of fitness for particular purpose

Every sale of consumer goods that are sold at retail in this state by a manufacturer who has reason to know at the time of the retail sale that the goods are required for a particular purpose and that the buyer is relying on the manufacturer’s skill or judgment to select or furnish suitable goods shall be accompanied by such manufacturer’s implied warranty of fitness.

Added Stats 1970 ch 1333 § 1. Amended Stats 1971 ch 1523 § 5, operative January 1, 1972; Stats 1978 ch 991 § 4.

### § 1792.2. Retailer’s or distributor’s implied warranty of fitness for particular purpose

(a) Every sale of consumer goods that are sold at retail in this state by a retailer or distributor who has reason to know at the time of the retail sale that the goods are required for a particular purpose, and that the buyer is relying on the retailer’s or distributor’s skill or judgment to select or furnish suitable goods shall be accompanied by such retailer’s or distributor’s implied warranty that the goods are fit for that purpose.

(b) Every sale of an assistive device sold at retail in this state shall be accompanied by the retail seller’s implied warranty that the device is specifically fit for the particular needs of the buyer.

Added Stats 1970 ch 1333 § 1. Amended Stats 1971 ch 1523 § 6, operative January 1, 1972; Stats 1978 ch 991 § 5; Stats 1979 ch 1023 § 2.

### § 1792.3. Waiver of implied warranties

No implied warranty of merchantability and, where applicable, no implied warranty of fitness shall be waived, except in the case of a sale of consumer goods on an “as is” or “with all faults” basis where the provisions of this chapter affecting “as is” or “with all faults” sales are strictly complied with.

Added Stats 1970 ch 1333 § 1.

**§ 1792.4. Disclaimer of implied warranty**

(a) No sale of goods, governed by the provisions of this chapter, on an “as is” or “with all faults” basis, shall be effective to disclaim the implied warranty of merchantability or, where applicable, the implied warranty of fitness, unless a conspicuous writing is attached to the goods which clearly informs the buyer, prior to the sale, in simple and concise language of each of the following:

(1) The goods are being sold on an “as is” or “with all faults” basis.

(2) The entire risk as to the quality and performance of the goods is with the buyer.

(3) Should the goods prove defective following their purchase, the buyer and not the manufacturer, distributor, or retailer assumes the entire cost of all necessary servicing or repair.

(b) In the event of sale of consumer goods by means of a mail order catalog, the catalog offering such goods shall contain the required writing as to each item so offered in lieu of the requirement of notification prior to the sale.

Added Stats 1970 ch 1333 § 1. Amended Stats 1971 ch 1523 § 6.5, operative January 1, 1972.

**§ 1792.5. “As is” sales**

Every sale of goods that are governed by the provisions of this chapter, on an “as is” or “with all faults” basis, made in compliance with the provisions of this chapter, shall constitute a waiver by the buyer of the implied warranty of merchantability and, where applicable, of the implied warranty of fitness.

Added Stats 1970 ch 1333 § 1. Amended Stats 1971 ch 1523 § 6.5, operative January 1, 1972.

**§ 1793. Express warranties**

Except as provided in Section 1793.02, nothing in this chapter shall affect the right of the manufacturer, distributor, or retailer to make express warranties with respect to consumer goods. However, a manufacturer, distributor, or retailer, in transacting a sale in which express warranties are given, may not limit, modify, or disclaim the implied warranties guaranteed by this chapter to the sale of consumer goods.

Added Stats 1970 ch 1333 § 1. Amended Stats 1971 ch 1523 § 7, operative January 1, 1972; Stats 1978 ch 991 § 6; Stats 1979 ch 1023 § 3.

**§ 1793.1. Form of express warranties; Requirements on distribution of warranty or product registration card or form, or electronic online warranty or product registration forms**

(a)(1) Every manufacturer, distributor, or retailer making express warranties with respect to consumer goods shall fully set forth those warranties in simple and readily understood language, which shall clearly identify the party making the express warranties, and which shall conform to the federal standards for disclosure of warranty terms and conditions set forth in the federal Magnuson–Moss Warranty–Federal Trade Commission Improvement Act (15 U.S.C. Sec. 2301 et seq.), and in the regulations of the Federal Trade Commission adopted pursuant to the provisions of that act. If the manufacturer, distributor, or retailer provides a warranty or product registration card or form, or an electronic online warranty or product registration form, to be completed

and returned by the consumer, the card or form shall contain statements, each displayed in a clear and conspicuous manner, that do all of the following:

(A) Informs the consumer that the card or form is for product registration.

(B) Informs the consumer that failure to complete and return the card or form does not diminish his or her warranty rights.

(2) Every work order or repair invoice for warranty repairs or service shall clearly and conspicuously incorporate in 10–point boldface type the following statement either on the face of the work order or repair invoice, or on the reverse side, or on an attachment to the work order or repair invoice: “A buyer of this product in California has the right to have this product serviced or repaired during the warranty period. The warranty period will be extended for the number of whole days that the product has been out of the buyer’s hands for warranty repairs. If a defect exists within the warranty period, the warranty will not expire until the defect has been fixed. The warranty period will also be extended if the warranty repairs have not been performed due to delays caused by circumstances beyond the control of the buyer, or if the warranty repairs did not remedy the defect and the buyer notifies the manufacturer or seller of the failure of the repairs within 60 days after they were completed. If, after a reasonable number of attempts, the defect has not been fixed, the buyer may return this product for a replacement or a refund subject, in either case, to deduction of a reasonable charge for usage. This time extension does not affect the protections or remedies the buyer has under other laws.”

If the required notice is placed on the reverse side of the work order or repair invoice, the face of the work order or repair invoice shall include the following notice in 10–point boldface type: “Notice to Consumer: Please read important information on back.”

A copy of the work order or repair invoice and any attachment shall be presented to the buyer at the time that warranty service or repairs are made.

(b) No warranty or product registration card or form, or an electronic online warranty or product registration form, may be labeled as a warranty registration or a warranty confirmation.

(c) The requirements imposed by this section on the distribution of any warranty or product registration card or form, or an electronic online warranty or product registration form, shall become effective on January 1, 2004.

(d) This section does not apply to any warranty or product registration card or form that was printed prior to January 1, 2004, and was shipped or included with a product that was placed in the stream of commerce prior to January 1, 2004.

(e) Every manufacturer, distributor, or retailer making express warranties and who elects to maintain service and repair facilities within this state pursuant to this chapter shall perform one or more of the following:

(1) At the time of sale, provide the buyer with the name and address of each service and repair facility within this state.

(2) At the time of the sale, provide the buyer with the name and address and telephone number of a service and repair facility central directory within this state, or

the toll-free telephone number of a service and repair facility central directory outside this state. It shall be the duty of the central directory to provide, upon inquiry, the name and address of the authorized service and repair facility nearest the buyer.

(3) Maintain at the premises of retail sellers of the warrantor's consumer goods a current listing of the warrantor's authorized service and repair facilities, or retail sellers to whom the consumer goods are to be returned for service and repair, whichever is applicable, within this state. It shall be the duty of every retail seller provided with that listing to provide, on inquiry, the name, address, and telephone number of the nearest authorized service and repair facility, or the retail seller to whom the consumer goods are to be returned for service and repair, whichever is applicable.

Added Stats 1970 ch 1333 § 1. Amended Stats 1971 ch 1523 § 8, operative January 1, 1972; Stats 1972 ch 1293 § 1; Stats 1980 ch 394 § 1; Stats 1981 ch 150 § 1, effective July 8, 1981; Stats 1982 ch 381 § 1; Stats 2002 ch 306 § 1 (SB 1765).

### § 1793.2. Duties of manufacturer making express warranty

(a) Every manufacturer of consumer goods sold in this state and for which the manufacturer has made an express warranty shall:

(1)(A) Maintain in this state sufficient service and repair facilities reasonably close to all areas where its consumer goods are sold to carry out the terms of those warranties or designate and authorize in this state as service and repair facilities independent repair or service facilities reasonably close to all areas where its consumer goods are sold to carry out the terms of the warranties.

(B) As a means of complying with this paragraph, a manufacturer may enter into warranty service contracts with independent service and repair facilities. The warranty service contracts may provide for a fixed schedule of rates to be charged for warranty service or warranty repair work. However, the rates fixed by those contracts shall be in conformity with the requirements of subdivision (c) of Section 1793.3. The rates established pursuant to subdivision (c) of Section 1793.3, between the manufacturer and the independent service and repair facility, do not preclude a good faith discount that is reasonably related to reduced credit and general overhead cost factors arising from the manufacturer's payment of warranty charges direct to the independent service and repair facility. The warranty service contracts authorized by this paragraph may not be executed to cover a period of time in excess of one year, and may be renewed only by a separate, new contract or letter of agreement between the manufacturer and the independent service and repair facility.

(2) In the event of a failure to comply with paragraph (1) of this subdivision, be subject to Section 1793.5.

(3) Make available to authorized service and repair facilities sufficient service literature and replacement parts to effect repairs during the express warranty period.

(b) Where those service and repair facilities are maintained in this state and service or repair of the goods is necessary because they do not conform with the applicable express warranties, service and repair shall be

commenced within a reasonable time by the manufacturer or its representative in this state. Unless the buyer agrees in writing to the contrary, the goods shall be serviced or repaired so as to conform to the applicable warranties within 30 days. Delay caused by conditions beyond the control of the manufacturer or its representatives shall serve to extend this 30-day requirement. Where delay arises, conforming goods shall be tendered as soon as possible following termination of the condition giving rise to the delay.

(c) The buyer shall deliver nonconforming goods to the manufacturer's service and repair facility within this state, unless, due to reasons of size and weight, or method of attachment, or method of installation, or nature of the nonconformity, delivery cannot reasonably be accomplished. If the buyer cannot return the nonconforming goods for any of these reasons, he or she shall notify the manufacturer or its nearest service and repair facility within the state. Written notice of nonconformity to the manufacturer or its service and repair facility shall constitute return of the goods for purposes of this section. Upon receipt of that notice of nonconformity, the manufacturer shall, at its option, service or repair the goods at the buyer's residence, or pick up the goods for service and repair, or arrange for transporting the goods to its service and repair facility. All reasonable costs of transporting the goods when a buyer cannot return them for any of the above reasons shall be at the manufacturer's expense. The reasonable costs of transporting nonconforming goods after delivery to the service and repair facility until return of the goods to the buyer shall be at the manufacturer's expense.

(d)(1) Except as provided in paragraph (2), if the manufacturer or its representative in this state does not service or repair the goods to conform to the applicable express warranties after a reasonable number of attempts, the manufacturer shall either replace the goods or reimburse the buyer in an amount equal to the purchase price paid by the buyer, less that amount directly attributable to use by the buyer prior to the discovery of the nonconformity.

(2) If the manufacturer or its representative in this state is unable to service or repair a new motor vehicle, as that term is defined in paragraph (2) of subdivision (e) of Section 1793.22, to conform to the applicable express warranties after a reasonable number of attempts, the manufacturer shall either promptly replace the new motor vehicle in accordance with subparagraph (A) or promptly make restitution to the buyer in accordance with subparagraph (B). However, the buyer shall be free to elect restitution in lieu of replacement, and in no event shall the buyer be required by the manufacturer to accept a replacement vehicle.

(A) In the case of replacement, the manufacturer shall replace the buyer's vehicle with a new motor vehicle substantially identical to the vehicle replaced. The replacement vehicle shall be accompanied by all express and implied warranties that normally accompany new motor vehicles of that specific kind. The manufacturer also shall pay for, or to, the buyer the amount of any sales or use tax, license fees, registration fees, and other official fees which the buyer is obligated to pay in connection with the replacement, plus any incidental damages to which the buyer is entitled under Section

1794, including, but not limited to, reasonable repair, towing, and rental car costs actually incurred by the buyer.

(B) In the case of restitution, the manufacturer shall make restitution in an amount equal to the actual price paid or payable by the buyer, including any charges for transportation and manufacturer-installed options, but excluding nonmanufacturer items installed by a dealer or the buyer, and including any collateral charges such as sales or use tax, license fees, registration fees, and other official fees, plus any incidental damages to which the buyer is entitled under Section 1794, including, but not limited to, reasonable repair, towing, and rental car costs actually incurred by the buyer.

(C) When the manufacturer replaces the new motor vehicle pursuant to subparagraph (A), the buyer shall only be liable to pay the manufacturer an amount directly attributable to use by the buyer of the replaced vehicle prior to the time the buyer first delivered the vehicle to the manufacturer or distributor, or its authorized service and repair facility for correction of the problem that gave rise to the nonconformity. When restitution is made pursuant to subparagraph (B), the amount to be paid by the manufacturer to the buyer may be reduced by the manufacturer by that amount directly attributable to use by the buyer prior to the time the buyer first delivered the vehicle to the manufacturer or distributor, or its authorized service and repair facility for correction of the problem that gave rise to the nonconformity. The amount directly attributable to use by the buyer shall be determined by multiplying the actual price of the new motor vehicle paid or payable by the buyer, including any charges for transportation and manufacturer-installed options, by a fraction having as its denominator 120,000 and having as its numerator the number of miles traveled by the new motor vehicle prior to the time the buyer first delivered the vehicle to the manufacturer or distributor, or its authorized service and repair facility for correction of the problem that gave rise to the nonconformity. Nothing in this paragraph shall in any way limit the rights or remedies available to the buyer under any other law.

(D) Pursuant to Section 1795.4, a buyer of a new motor vehicle shall also include a lessee of a new motor vehicle.

(e)(1) If the goods cannot practicably be serviced or repaired by the manufacturer or its representative to conform to the applicable express warranties because of the method of installation or because the goods have become so affixed to real property as to become a part thereof, the manufacturer shall either replace and install the goods or reimburse the buyer in an amount equal to the purchase price paid by the buyer, including installation costs, less that amount directly attributable to use by the buyer prior to the discovery of the nonconformity.

(2) With respect to claims arising out of deficiencies in the construction of a new residential dwelling, paragraph (1) shall not apply to either of the following:

(A) A product that is not a manufactured product, as defined in subdivision (g) of Section 896.

(B) A claim against a person or entity that is not the manufacturer that originally made the express warranty for that manufactured product.

Added Stats 1970 ch 1333 § 1. Amended Stats 1971 ch 1523 § 9, operative January 1, 1972; Stats 1976 ch 416 § 2; Stats 1978 ch 991 § 7; Stats 1982 ch 388 § 1; Stats 1986 ch 547 § 2; Stats 1987 ch 1280 § 2; Stats 1988 ch 697 § 1; Stats 1989 ch 193 § 2; Stats 1991 ch 689 § 10 (AB 211); Stats 1992 ch 1232 § 6 (SB 1762); Stats 2004 ch 331 § 1 (AB 2723); Stats 2011 ch 727 § 1 (AB 242), effective January 1, 2012.

**§ 1793.22. Reasonable number of attempts to conform vehicle to warranties; Dispute resolution process; Transfer of vehicle**

(a) This section shall be known and may be cited as the Tanner Consumer Protection Act.

(b) It shall be presumed that a reasonable number of attempts have been made to conform a new motor vehicle to the applicable express warranties if, within 18 months from delivery to the buyer or 18,000 miles on the odometer of the vehicle, whichever occurs first, one or more of the following occurs:

(1) The same nonconformity results in a condition that is likely to cause death or serious bodily injury if the vehicle is driven and the nonconformity has been subject to repair two or more times by the manufacturer or its agents, and the buyer or lessee has at least once directly notified the manufacturer of the need for the repair of the nonconformity.

(2) The same nonconformity has been subject to repair four or more times by the manufacturer or its agents and the buyer has at least once directly notified the manufacturer of the need for the repair of the nonconformity.

(3) The vehicle is out of service by reason of repair of nonconformities by the manufacturer or its agents for a cumulative total of more than 30 calendar days since delivery of the vehicle to the buyer. The 30-day limit shall be extended only if repairs cannot be performed due to conditions beyond the control of the manufacturer or its agents. The buyer shall be required to directly notify the manufacturer pursuant to paragraphs (1) and (2) only if the manufacturer has clearly and conspicuously disclosed to the buyer, with the warranty or the owner's manual, the provisions of this section and that of subdivision (d) of Section 1793.2, including the requirement that the buyer must notify the manufacturer directly pursuant to paragraphs (1) and (2). The notification, if required, shall be sent to the address, if any, specified clearly and conspicuously by the manufacturer in the warranty or owner's manual. This presumption shall be a rebuttable presumption affecting the burden of proof, and it may be asserted by the buyer in any civil action, including an action in small claims court, or other formal or informal proceeding.

(c) If a qualified third-party dispute resolution process exists, and the buyer receives timely notification in writing of the availability of that qualified third-party dispute resolution process with a description of its operation and effect, the presumption in subdivision (b) may not be asserted by the buyer until after the buyer has initially resorted to the qualified third-party dispute resolution process as required in subdivision (d). Notification of the availability of the qualified third-party dispute resolution process is not timely if the buyer suffers any prejudice resulting from any delay in giving

the notification. If a qualified third-party dispute resolution process does not exist, or if the buyer is dissatisfied with that third-party decision, or if the manufacturer or its agent neglects to promptly fulfill the terms of the qualified third-party dispute resolution process decision after the decision is accepted by the buyer, the buyer may assert the presumption provided in subdivision (b) in an action to enforce the buyer's rights under subdivision (d) of Section 1793.2. The findings and decision of a qualified third-party dispute resolution process shall be admissible in evidence in the action without further foundation. Any period of limitation of actions under any federal or California laws with respect to any person shall be extended for a period equal to the number of days between the date a complaint is filed with a third-party dispute resolution process and the date of its decision or the date before which the manufacturer or its agent is required by the decision to fulfill its terms if the decision is accepted by the buyer, whichever occurs later.

(d) A qualified third-party dispute resolution process shall be one that does all of the following:

(1) Complies with the minimum requirements of the Federal Trade Commission for informal dispute settlement procedures as set forth in Part 703 of Title 16 of the Code of Federal Regulations, as those regulations read on January 1, 1987.

(2) Renders decisions which are binding on the manufacturer if the buyer elects to accept the decision.

(3) Prescribes a reasonable time, not to exceed 30 days after the decision is accepted by the buyer, within which the manufacturer or its agent must fulfill the terms of its decisions.

(4) Provides arbitrators who are assigned to decide disputes with copies of, and instruction in, the provisions of the Federal Trade Commission's regulations in Part 703 of Title 16 of the Code of Federal Regulations as those regulations read on January 1, 1987, Division 2 (commencing with Section 2101) of the Commercial Code, and this chapter.

(5) Requires the manufacturer, when the process orders, under the terms of this chapter, either that the nonconforming motor vehicle be replaced if the buyer consents to this remedy or that restitution be made to the buyer, to replace the motor vehicle or make restitution in accordance with paragraph (2) of subdivision (d) of Section 1793.2.

(6) Provides, at the request of the arbitrator or a majority of the arbitration panel, for an inspection and written report on the condition of a nonconforming motor vehicle, at no cost to the buyer, by an automobile expert who is independent of the manufacturer.

(7) Takes into account, in rendering decisions, all legal and equitable factors, including, but not limited to, the written warranty, the rights and remedies conferred in regulations of the Federal Trade Commission contained in Part 703 of Title 16 of the Code of Federal Regulations as those regulations read on January 1, 1987, Division 2 (commencing with Section 2101) of the Commercial Code, this chapter, and any other equitable considerations appropriate in the circumstances. Nothing in this chapter requires that, to be certified as a qualified third-party dispute resolution process pursuant to this section, decisions of the process must consider

or provide remedies in the form of awards of punitive damages or multiple damages, under subdivision (c) of Section 1794, or of attorneys' fees under subdivision (d) of Section 1794, or of consequential damages other than as provided in subdivisions (a) and (b) of Section 1794, including, but not limited to, reasonable repair, towing, and rental car costs actually incurred by the buyer.

(8) Requires that no arbitrator deciding a dispute may be a party to the dispute and that no other person, including an employee, agent, or dealer for the manufacturer, may be allowed to participate substantively in the merits of any dispute with the arbitrator unless the buyer is allowed to participate also. Nothing in this subdivision prohibits any member of an arbitration board from deciding a dispute.

(9) Obtains and maintains certification by the Department of Consumer Affairs pursuant to Chapter 9 (commencing with Section 472) of Division 1 of the Business and Professions Code.

(e) For the purposes of subdivision (d) of Section 1793.2 and this section, the following terms have the following meanings:

(1) "Nonconformity" means a nonconformity which substantially impairs the use, value, or safety of the new motor vehicle to the buyer or lessee.

(2) "New motor vehicle" means a new motor vehicle that is bought or used primarily for personal, family, or household purposes. "New motor vehicle" also means a new motor vehicle with a gross vehicle weight under 10,000 pounds that is bought or used primarily for business purposes by a person, including a partnership, limited liability company, corporation, association, or any other legal entity, to which not more than five motor vehicles are registered in this state. "New motor vehicle" includes the chassis, chassis cab, and that portion of a motor home devoted to its propulsion, but does not include any portion designed, used, or maintained primarily for human habitation, a dealer-owned vehicle and a "demonstrator" or other motor vehicle sold with a manufacturer's new car warranty but does not include a motorcycle or a motor vehicle which is not registered under the Vehicle Code because it is to be operated or used exclusively off the highways. A demonstrator is a vehicle assigned by a dealer for the purpose of demonstrating qualities and characteristics common to vehicles of the same or similar model and type.

(3) "Motor home" means a vehicular unit built on, or permanently attached to, a self-propelled motor vehicle chassis, chassis cab, or van, which becomes an integral part of the completed vehicle, designed for human habitation for recreational or emergency occupancy.

(f)(1) Except as provided in paragraph (2), no person shall sell, either at wholesale or retail, lease, or transfer a motor vehicle transferred by a buyer or lessee to a manufacturer pursuant to paragraph (2) of subdivision (d) of Section 1793.2 or a similar statute of any other state, unless the nature of the nonconformity experienced by the original buyer or lessee is clearly and conspicuously disclosed to the prospective buyer, lessee, or transferee, the nonconformity is corrected, and the manufacturer warrants to the new buyer, lessee, or transferee in writing for a period of one year that the motor vehicle is free of that nonconformity.

(2) Except for the requirement that the nature of the nonconformity be disclosed to the transferee, paragraph (1) does not apply to the transfer of a motor vehicle to an educational institution if the purpose of the transfer is to make the motor vehicle available for use in automotive repair courses.

Added Stats 1992 ch 1232 § 7 (SB 1762). Amended Stats 1998 ch 352 § 1 (AB 1848); Stats 1999 ch 83 § 21 (SB 966), ch 448 § 1 (AB 1290) (ch 448 prevails); Stats 2000 ch 679 § 1 (SB 1718).

**§ 1793.23. Disclosures required of seller of returned vehicle; “Lemon Law Buyback”**

(a) The Legislature finds and declares all of the following:

(1) That the expansion of state warranty laws covering new and used cars has given important and valuable protection to consumers.

(2) That, in states without this valuable warranty protection, used and irreparable motor vehicles are being resold in the marketplace without notice to the subsequent purchaser.

(3) That other states have addressed this problem by requiring notices on the title of these vehicles or other notice procedures to warn consumers that the motor vehicles were repurchased by a dealer or manufacturer because the vehicle could not be repaired in a reasonable length of time or a reasonable number of repair attempts or the dealer or manufacturer was not willing to repair the vehicle.

(4) That these notices serve the interests of consumers who have a right to information relevant to their buying decisions.

(5) That the disappearance of these notices upon the transfer of title from another state to this state encourages the transport of “lemons” to this state for sale to the drivers of this state.

(b) This section and Section 1793.24 shall be known, and may be cited as, the Automotive Consumer Notification Act.

(c) Any manufacturer who reacquires or assists a dealer or lienholder to reacquire a motor vehicle registered in this state, any other state, or a federally administered district shall, prior to any sale, lease, or transfer of the vehicle in this state, or prior to exporting the vehicle to another state for sale, lease, or transfer if the vehicle was registered in this state and reacquired pursuant to paragraph (2) of subdivision (d) of Section 1793.2, cause the vehicle to be retitled in the name of the manufacturer, request the Department of Motor Vehicles to inscribe the ownership certificate with the notation “Lemon Law Buyback,” and affix a decal to the vehicle in accordance with Section 11713.12 of the Vehicle Code if the manufacturer knew or should have known that the vehicle is required by law to be replaced, accepted for restitution due to the failure of the manufacturer to conform the vehicle to applicable warranties pursuant to paragraph (2) of subdivision (d) of Section 1793.2, or accepted for restitution by the manufacturer due to the failure of the manufacturer to conform the vehicle to warranties required by any other applicable law of the state, any other state, or federal law.

(d) Any manufacturer who reacquires or assists a dealer or lienholder to reacquire a motor vehicle in response to a request by the buyer or lessee that the

vehicle be either replaced or accepted for restitution because the vehicle did not conform to express warranties shall, prior to the sale, lease, or other transfer of the vehicle, execute and deliver to the subsequent transferee a notice and obtain the transferee’s written acknowledgment of a notice, as prescribed by Section 1793.24.

(e) Any person, including any dealer, who acquires a motor vehicle for resale and knows or should have known that the vehicle was reacquired by the vehicle’s manufacturer in response to a request by the last retail owner or lessee of the vehicle that it be replaced or accepted for restitution because the vehicle did not conform to express warranties shall, prior to the sale, lease, or other transfer, execute and deliver to the subsequent transferee a notice and obtain the transferee’s written acknowledgment of a notice, as prescribed by Section 1793.24.

(f) Any person, including any manufacturer or dealer, who sells, leases, or transfers ownership of a motor vehicle when the vehicle’s ownership certificate is inscribed with the notation “Lemon Law Buyback” shall, prior to the sale, lease, or ownership transfer of the vehicle, provide the transferee with a disclosure statement signed by the transferee that states:

“THIS VEHICLE WAS REPURCHASED BY ITS MANUFACTURER DUE TO A DEFECT IN THE VEHICLE PURSUANT TO CONSUMER WARRANTY LAWS. THE TITLE TO THIS VEHICLE HAS BEEN PERMANENTLY BRANDED WITH THE NOTATION ‘LEMON LAW BUYBACK.’”

(g) The disclosure requirements in subdivisions (d), (e), and (f) are cumulative with all other consumer notice requirements and do not relieve any person, including any dealer or manufacturer, from complying with any other applicable law, including any requirement of subdivision (f) of Section 1793.22.

(h) For purposes of this section, “dealer” means any person engaged in the business of selling, offering for sale, or negotiating the retail sale of, a used motor vehicle or selling motor vehicles as a broker or agent for another, including the officers, agents, and employees of the person and any combination or association of dealers.

Added Stats 1995 ch 503 § 1 (AB 1381). Amended Stats 1998 ch 932 § 7 (AB 1094).

**§ 1793.24. Warranty buyback notice**

(a) The notice required in subdivisions (d) and (e) of Section 1793.23 shall be prepared by the manufacturer of the reacquired vehicle and shall disclose all of the following:

(1) Year, make, model, and vehicle identification number of the vehicle.

(2) Whether the title to the vehicle has been inscribed with the notation “Lemon Law Buyback.”

(3) The nature of each nonconformity reported by the original buyer or lessee of the vehicle.

(4) Repairs, if any, made to the vehicle in an attempt to correct each nonconformity reported by the original buyer or lessee.

(b) The notice shall be on a form 8½ × 11 inches in size and printed in no smaller than 10–point black type on a white background.

The form shall only contain the following information prior to it being filled out by the manufacturer:



WARRANTY BUYBACK NOTICE

(Check One)

This vehicle was repurchased by the vehicle's manufacturer after the last retail owner or lessee requested its repurchase due to the problem(s) listed below.

THIS VEHICLE WAS REPURCHASED BY ITS MANUFACTURER DUE TO A DEFECT IN THE VE-

HICLE PURSUANT TO CONSUMER WARRANTY LAWS. THE TITLE TO THIS VEHICLE HAS BEEN PERMANENTLY BRANDED WITH THE NOTATION "LEMON LAW BUYBACK." Under California law, the manufacturer must warrant to you, for a one year period, that the vehicle is free of the problem(s) listed below.

V.I.N.	Year	Make	Model
Problem(s) Reported by Original Owner		Repairs Made, if any, to Correct Reported Problem(s)	

Signature of Manufacturer	Date
Signature of Dealer(s)	Date
Signature of Retail Buyer or Lessee	Date
Signature of Manufacturer	Date
Signature of Dealer(s)	Date
Signature of Retail Buyer or Lessee	Date

(c) The manufacturer shall provide an executed copy of the notice to the manufacturer's transferee. Each transferee, including a dealer, to whom the motor vehicle is transferred prior to its sale to a retail buyer or lessee shall be provided an executed copy of the notice by the previous transferor.

Added Stats 1995 ch 503 § 2 (AB 1381).

§ 1793.25. Sales tax reimbursement to vehicle manufacturer after restitution under express warranty

(a) Notwithstanding Part 1 (commencing with Section 6001) of Division 2 of the Revenue and Taxation Code, the State Board of Equalization shall reimburse the manufacturer of a new motor vehicle for an amount equal to the sales tax or use tax which the manufacturer pays to or for the buyer or lessee when providing a replacement vehicle pursuant to subparagraph (A) of paragraph (2) of subdivision (d) of Section 1793.2 or includes in making restitution to the buyer or lessee pursuant to subparagraph (B) of paragraph (2) of subdivision (d) of Section 1793.2, when the manufacturer provides satisfactory proof that it has complied with subdivision (c) of Section 1793.23, and satisfactory proof is provided for one of the following:

(1) The retailer of the motor vehicle for which the manufacturer is making restitution has reported and

paid the sales tax on the gross receipts from the sale of that motor vehicle.

(2) The buyer of the motor vehicle has paid the use tax on the sales price for the storage, use, or other consumption of that motor vehicle in this state.

(3) The lessee of the motor vehicle has paid the use tax on the rentals payable from the lease of that motor vehicle.

(b) The State Board of Equalization may adopt rules and regulations to carry out, facilitate compliance with, or prevent circumvention or evasion of, this section.

(c) This section shall not change the application of the sales and use tax to the gross receipts, the rentals payable, and the sales price from the sale, lease, and the storage, use, or other consumption, in this state of tangible personal property pursuant to Part 1 (commencing with Section 6001) of Division 2 of the Revenue and Taxation Code.

(d) The manufacturer's claim for reimbursement and the State Board of Equalization's approval or denial of the claim shall be subject to the provisions of Article 1 (commencing with Section 6901) of Chapter 7 of Part 1 of Division 2 of the Revenue and Taxation Code, except Sections 6907 and 6908, insofar as those provisions are not inconsistent with this section.

(e) For purposes of this section, the amount of use tax that the State Board of Equalization is required to reimburse the manufacturer shall be limited to the

amount of use tax the manufacturer is required to pay to or for the lessee pursuant to Section 1793.2.

Added Stats 1987 ch 1280 § 3. Amended Stats 1995 ch 503 § 3 (AB 1381); Stats 2011 ch 727 § 2 (AB 242), effective January 1, 2012.

**§ 1793.26. Restrictions on confidentiality clause, gag clause, or other similar clause associated with reacquisition of motor vehicle**

(a) Any automobile manufacturer, importer, distributor, dealer, or lienholder who reacquires, or who assists in reacquiring, a motor vehicle, whether by judgment, decree, arbitration award, settlement agreement, or voluntary agreement, is prohibited from doing either of the following:

(1) Requiring, as a condition of the reacquisition of the motor vehicle, that a buyer or lessee who is a resident of this state agree not to disclose the problems with the vehicle experienced by the buyer or lessee or the nonfinancial terms of the reacquisition.

(2) Including, in any release or other agreement, whether prepared by the manufacturer, importer, distributor, dealer, or lienholder, for signature by the buyer or lessee, a confidentiality clause, gag clause, or similar clause prohibiting the buyer or lessee from disclosing information to anyone about the problems with the vehicle, or the nonfinancial terms of the reacquisition of the vehicle by the manufacturer, importer, distributor, dealer, or lienholder.

(b) Any confidentiality clause, gag clause, or similar clause in such a release or other agreement in violation of this section shall be null and void as against the public policy of this state.

(c) Nothing in this section is intended to prevent any confidentiality clause, gag clause, or similar clause regarding the financial terms of the reacquisition of the vehicle.

Added Stats 1998 ch 1063 § 1 (AB 2410). Amended Stats 2000 ch 258 § 1 (AB 2517).

**§ 1793.3. Failure to provide service facility in conjunction with express warranty**

If the manufacturer of consumer goods sold in this state for which the manufacturer has made an express warranty does not provide service and repair facilities within this state pursuant to subdivision (a) of Section 1793.2, or does not make available to authorized service and repair facilities service literature and replacement parts sufficient to effect repair during the express warranty period, the buyer of such manufacturer's nonconforming goods may follow the course of action prescribed in either subdivision (a), (b), or (c), below, as follows:

(a) Return the nonconforming consumer goods to the retail seller thereof. The retail seller shall do one of the following:

(1) Service or repair the nonconforming goods to conform to the applicable warranty.

(2) Direct the buyer to a reasonably close independent repair or service facility willing to accept service or repair under this section.

(3) Replace the nonconforming goods with goods that are identical or reasonably equivalent to the warranted goods.

(4) Refund to the buyer the original purchase price less that amount directly attributable to use by the buyer prior to the discovery of the nonconformity.

(b) Return the nonconforming consumer goods to any retail seller of like goods of the same manufacturer within this state who may do one of the following:

(1) Service or repair the nonconforming goods to conform to the applicable warranty.

(2) Direct the buyer to a reasonably close independent repair or service facility willing to accept service or repair under this section.

(3) Replace the nonconforming goods with goods that are identical or reasonably equivalent to the warranted goods.

(4) Refund to the buyer the original purchase price less that amount directly attributable to use by the buyer prior to the discovery of the nonconformity.

(c) Secure the services of an independent repair or service facility for the service or repair of the nonconforming consumer goods, when service or repair of the goods can be economically accomplished. In that event the manufacturer shall be liable to the buyer, or to the independent repair or service facility upon an assignment of the buyer's rights, for the actual and reasonable cost of service and repair, including any cost for parts and any reasonable cost of transporting the goods or parts, plus a reasonable profit. It shall be a rebuttable presumption affecting the burden of producing evidence that the reasonable cost of service or repair is an amount equal to that which is charged by the independent service dealer for like services or repairs rendered to service or repair customers who are not entitled to warranty protection. Any waiver of the liability of a manufacturer shall be void and unenforceable.

The course of action prescribed in this subdivision shall be available to the buyer only after the buyer has followed the course of action prescribed in either subdivision (a) or (b) and such course of action has not furnished the buyer with appropriate relief. In no event, shall the provisions of this subdivision be available to the buyer with regard to consumer goods with a wholesale price to the retailer of less than fifty dollars (\$50). In no event shall the buyer be responsible or liable for service or repair costs charged by the independent repair or service facility which accepts service or repair of nonconforming consumer goods under this section. Such independent repair or service facility shall only be authorized to hold the manufacturer liable for such costs.

(d) A retail seller to which any nonconforming consumer good is returned pursuant to subdivision (a) or (b) shall have the option of providing service or repair itself or directing the buyer to a reasonably close independent repair or service facility willing to accept service or repair under this section. In the event the retail seller directs the buyer to an independent repair or service facility, the manufacturer shall be liable for the reasonable cost of repair services in the manner provided in subdivision (c).

(e) In the event a buyer is unable to return nonconforming goods to the retailer due to reasons of size and weight, or method of attachment, or method of installation, or nature of the nonconformity, the buyer shall give notice of the nonconformity to the retailer. Upon receipt of such notice of nonconformity the retailer shall, at its option, service or repair the goods at the buyer's residence, or pick up the goods for service or repair, or arrange for transporting the goods to its place of busi-

ness. The reasonable costs of transporting the goods shall be at the retailer's expense. The retailer shall be entitled to recover all such reasonable costs of transportation from the manufacturer pursuant to Section 1793.5. The reasonable costs of transporting nonconforming goods after delivery to the retailer until return of the goods to the buyer, when incurred by a retailer, shall be recoverable from the manufacturer pursuant to Section 1793.5. Written notice of nonconformity to the retailer shall constitute return of the goods for the purposes of subdivisions (a) and (b).

(f) The manufacturer of consumer goods with a wholesale price to the retailer of fifty dollars (\$50) or more for which the manufacturer has made express warranties shall provide written notice to the buyer of the courses of action available to him under subdivision (a), (b), or (c).

Added Stats 1970 ch 1333 § 1. Amended Stats 1971 ch 1523 § 10, operative January 1, 1972; Stats 1976 ch 416 § 3; Stats 1978 ch 991 § 8; Stats 1986 ch 547 § 3.

#### **§ 1793.4. Time to exercise option for service of item under express warranty**

Where an option is exercised in favor of service and repair under Section 1793.3, such service and repair must be commenced within a reasonable time, and, unless the buyer agrees in writing to the contrary, goods conforming to the applicable express warranties shall be tendered within 30 days. Delay caused by conditions beyond the control of the retail seller or his representative shall serve to extend this 30-day requirement. Where such a delay arises, conforming goods shall be tendered as soon as possible following termination of the condition giving rise to the delay.

Added Stats 1970 ch 1333 § 1. Amended Stats 1971 ch 1523 § 11, operative January 1, 1972; Stats 1978 ch 991 § 9.

#### **§ 1793.5. Liability of manufacturer making express warranties for failure to maintain service facilities**

Every manufacturer making express warranties who does not provide service and repair facilities within this state pursuant to subdivision (a) of Section 1793.2 shall be liable as prescribed in this section to every retail seller of such manufacturer's goods who incurs obligations in giving effect to the express warranties that accompany such manufacturer's consumer goods. The amount of such liability shall be determined as follows:

(a) In the event of replacement, in an amount equal to the actual cost to the retail seller of the replaced goods, and cost of transporting the goods, if such costs are incurred plus a reasonable handling charge.

(b) In the event of service and repair, in an amount equal to that which would be received by the retail seller for like service rendered to retail consumers who are not entitled to warranty protection, including actual and reasonable costs of the service and repair and the cost of transporting the goods, if such costs are incurred, plus a reasonable profit.

(c) In the event of reimbursement under subdivision (a) of Section 1793.3, in an amount equal to that reimbursed to the buyer, plus a reasonable handling charge.

Added Stats 1970 ch 1333 § 1. Amended Stats 1971 ch 1523 § 12, operative January 1, 1972.

#### **§ 1793.6. Manufacturer's liability to independent serviceman performing services or incurring obligations on express warranties**

Except as otherwise provided in the terms of a warranty service contract, as specified in subdivision (a) of Section 1793.2, entered into between a manufacturer and an independent service and repair facility, every manufacturer making express warranties whose consumer goods are sold in this state shall be liable as prescribed in this section to every independent serviceman who performs services or incurs obligations in giving effect to the express warranties that accompany such manufacturer's consumer goods whether the independent serviceman is acting as an authorized service and repair facility designated by the manufacturer pursuant to paragraph (1) of subdivision (a) of Section 1793.2 or is acting as an independent serviceman pursuant to subdivisions (c) and (d) of Section 1793.3. The amount of such liability shall be an amount equal to the actual and reasonable costs of the service and repair, including any cost for parts and any reasonable cost of transporting the goods or parts, plus a reasonable profit. It shall be a rebuttable presumption affecting the burden of producing evidence that the reasonable cost of service or repair is an amount equal to that which is charged by the independent serviceman for like services or repairs rendered to service or repair customers who are not entitled to warranty protection. Any waiver of the liability of a manufacturer shall be void and unenforceable.

Added Stats 1976 ch 416 § 4.

#### **§ 1794. Buyer's damages, penalties and fees**

(a) Any buyer of consumer goods who is damaged by a failure to comply with any obligation under this chapter or under an implied or express warranty or service contract may bring an action for the recovery of damages and other legal and equitable relief.

(b) The measure of the buyer's damages in an action under this section shall include the rights of replacement or reimbursement as set forth in subdivision (d) of Section 1793.2, and the following:

(1) Where the buyer has rightfully rejected or justifiably revoked acceptance of the goods or has exercised any right to cancel the sale, Sections 2711, 2712, and 2713 of the Commercial Code shall apply.

(2) Where the buyer has accepted the goods, Sections 2714 and 2715 of the Commercial Code shall apply, and the measure of damages shall include the cost of repairs necessary to make the goods conform.

(c) If the buyer establishes that the failure to comply was willful, the judgment may include, in addition to the amounts recovered under subdivision (a), a civil penalty which shall not exceed two times the amount of actual damages. This subdivision shall not apply in any class action under Section 382 of the Code of Civil Procedure or under Section 1781, or with respect to a claim based solely on a breach of an implied warranty.

(d) If the buyer prevails in an action under this section, the buyer shall be allowed by the court to recover as part of the judgment a sum equal to the aggregate amount of costs and expenses, including attorney's fees based on actual time expended, determined by the court to have been reasonably incurred by the buyer in con-

nection with the commencement and prosecution of such action.

(e)(1) Except as otherwise provided in this subdivision, if the buyer establishes a violation of paragraph (2) of subdivision (d) of Section 1793.2, the buyer shall recover damages and reasonable attorney's fees and costs, and may recover a civil penalty of up to two times the amount of damages.

(2) If the manufacturer maintains a qualified third-party dispute resolution process which substantially complies with Section 1793.22, the manufacturer shall not be liable for any civil penalty pursuant to this subdivision.

(3) After the occurrence of the events giving rise to the presumption established in subdivision (b) of Section 1793.22, the buyer may serve upon the manufacturer a written notice requesting that the manufacturer comply with paragraph (2) of subdivision (d) of Section 1793.2. If the buyer fails to serve the notice, the manufacturer shall not be liable for a civil penalty pursuant to this subdivision.

(4) If the buyer serves the notice described in paragraph (3) and the manufacturer complies with paragraph (2) of subdivision (d) of Section 1793.2 within 30 days of the service of that notice, the manufacturer shall not be liable for a civil penalty pursuant to this subdivision.

(5) If the buyer recovers a civil penalty under subdivision (c), the buyer may not also recover a civil penalty under this subdivision for the same violation.

Added Stats 1982 ch 385 § 2. Amended Stats 1987 ch 1280 § 4; Stats 1992 ch 1232 § 9 (SB 1762).

#### § 1794.1. Seller's and serviceman's damages

(a) Any retail seller of consumer goods injured by the willful or repeated violation of the provisions of this chapter may bring an action for the recovery of damages. Judgment may be entered for three times the amount at which the actual damages are assessed plus reasonable attorney fees.

(b) Any independent serviceman of consumer goods injured by the willful or repeated violation of the provisions of this chapter may bring an action for the recovery of damages. Judgment may be entered for three times the amount at which the actual damages are assessed plus reasonable attorney fees.

Added Stats 1970 ch 1333 § 1. Amended Stats 1976 ch 416 § 5.

#### § 1794.4. Service contract in lieu of warranty

(a) Nothing in this chapter shall be construed to prevent the sale of a service contract to the buyer in addition to or in lieu of an express warranty if that contract fully and conspicuously discloses in simple and readily understood language the terms, conditions, and exclusions of that contract, provided that nothing in this section shall apply to a home protection contract issued by a home protection company that is subject to Part 7 (commencing with Section 12740) of Division 2 of the Insurance Code.

(b) Except as otherwise expressly provided in the service contract, every service contract shall obligate the service contractor to provide to the buyer of the product all of the services and functional parts that may be necessary to maintain proper operation of the entire

product under normal operation and service for the duration of the service contract and without additional charge.

(c) The service contract shall contain all of the following items of information:

(1) A clear description and identification of the covered product.

(2) The point in time or event when the term of the service contract commences, and its duration measured by elapsed time or an objective measure of use.

(3) If the enforceability of the service contract is limited to the original buyer or is limited to persons other than every consumer owner of the covered product during the term of the service contract, a description of the limits on transfer or assignment of the service contract.

(4) A statement of the general obligation of the service contractor in the same language set forth in subdivision (b), with equally clear and conspicuous statements of the following:

(A) Any services, parts, characteristics, components, properties, defects, malfunctions, causes, conditions, repairs, or remedies that are excluded from the scope of the service contract.

(B) Any other limits on the application of the language in subdivision (b) such as a limit on the total number of service calls.

(C) Any additional services that the service contractor will provide.

(D) Whether the obligation of the service contractor includes preventive maintenance and, if so, the nature and frequency of the preventive maintenance that the service contractor will provide.

(E) Whether the buyer has an obligation to provide preventive maintenance or perform any other obligations and, if so, the nature and frequency of the preventive maintenance and of any other obligations, and the consequences of any noncompliance.

(5) A step-by-step explanation of the procedure that the buyer should follow in order to obtain performance of any obligation under the service contract including the following:

(A) The full legal and business name of the service contractor.

(B) The mailing address of the service contractor.

(C) The persons or class of persons that are authorized to perform service.

(D) The name or title and address of any agent, employee, or department of the service contractor that is responsible for the performance of any obligations.

(E) The method of giving notice to the service contractor of the need for service.

(F) Whether in-home service is provided or, if not, whether the costs of transporting the product, for service or repairs will be paid by the service contractor.

(G) If the product must be transported to the service contractor, either the place where the product may be delivered for service or repairs or a toll-free telephone number that the buyer may call to obtain that information.

(H) All other steps that the buyer must take to obtain service.

(I) All fees, charges, and other costs that the buyer must pay to obtain service.

(6) An explanation of the steps that the service contractor will take to carry out its obligations under the service contract.

(7) A description of any right to cancel the contract if the buyer returns the product or the product is sold, lost, stolen, or destroyed, or, if there is no right to cancel or the right to cancel is limited, a statement of the fact.

(8) Information respecting the availability of any informal dispute settlement process.

(d) Subdivisions (b) and (c) are applicable to service contracts on new or used home appliances and home electronic products entered into on or after July 1, 1989. They are applicable to service contracts on all other new or used products entered into on and after July 1, 1991.

(e) This section shall become operative on January 1, 2008.

Added Stats 1993 ch 1265 § 13.5 (SB 798), operative January 1, 1998. Amended Stats 1997 ch 401 § 65 (SB 780), operative January 1, 2003; Stats 2002 ch 405 § 64 (AB 2973), operative January 1, 2008.

**§ 1794.41. Vehicle, home appliance, or home electronic product service contract; Requirements; Applicability; Conflicts with insurance provisions**

(a) No service contract covering any motor vehicle, home appliance, or home electronic product purchased for use in this state may be offered for sale or sold unless all of the following elements exist:

(1) The contract shall contain the disclosures specified in Section 1794.4 and shall disclose in the manner described in that section the buyer's cancellation and refund rights provided by this section.

(2) The contract shall be available for inspection by the buyer prior to purchase and either the contract, or a brochure which specifically describes the terms, conditions, and exclusions of the contract, and the provisions of this section relating to contract delivery, cancellation, and refund, shall be delivered to the buyer at or before the time of purchase of the contract. Within 60 days after the date of purchase, the contract itself shall be delivered to the buyer. If a service contract for a home appliance or a home electronic product is sold by means of a telephone solicitation, the seller may elect to satisfy the requirements of this paragraph by mailing or delivering the contract to the buyer not later than 30 days after the date of the sale of the contract.

(3) The contract is applicable only to items, costs, and time periods not covered by the express warranty. However, a service contract may run concurrently with or overlap an express warranty if (A) the contract covers items or costs not covered by the express warranty or (B) the contract provides relief to the purchaser not available under the express warranty, such as automatic replacement of a product where the express warranty only provides for repair.

(4) The contract shall be cancelable by the purchaser under the following conditions:

(A) Unless the contract provides for a longer period, within the first 60 days after receipt of the contract, or with respect to a contract covering a used motor vehicle without manufacturer warranties, a home appliance, or a home electronic product, within the first 30 days after receipt of the contract, the full amount paid shall be refunded by the seller to the purchaser if the purchaser provides a written notice of cancellation to the person

specified in the contract, and if no claims have been made against the contract. If a claim has been made against the contract either within the first 60 days after receipt of the contract, or with respect to a used motor vehicle without manufacturer warranties, home appliance, or home electronic product, within the first 30 days after receipt of the contract, a pro rata refund, based on either elapsed time or an objective measure of use, such as mileage or the retail value of any service performed, at the seller's option as indicated in the contract, or for a vehicle service contract at the obligor's option as determined at the time of cancellation, shall be made by the seller to the purchaser if the purchaser provides a written notice of cancellation to the person specified in the contract.

(B) Unless the contract provides for a longer period for obtaining a full refund, after the first 60 days after receipt of the contract, or with respect to a contract covering a used motor vehicle without manufacturer warranties, a home appliance, or a home electronic product, after the first 30 days after the receipt of the contract, a pro rata refund, based on either elapsed time or an objective measure of use, such as mileage or the retail value of any service performed, at the seller's option as indicated in the contract, or for a vehicle service contract at the obligor's option as determined at the time of cancellation, shall be made by the seller to the purchaser if the purchaser provides a written notice of cancellation to the person specified in the contract. In addition, the seller may assess a cancellation or administrative fee, not to exceed 10 percent of the price of the service contract or twenty-five dollars (\$25), whichever is less.

(C) If the purchase of the service contract was financed, the seller may make the refund payable to the purchaser, the assignee, or lender of record, or both.

(b) Nothing in this section shall apply to a home protection plan that is issued by a home protection company which is subject to Part 7 (commencing with Section 12740) of Division 2 of the Insurance Code.

(c) If any provision of this section conflicts with any provision of Part 8 (commencing with Section 12800) of Division 2 of the Insurance Code, the provision of the Insurance Code shall apply instead of this section.

Added Stats 1985 ch 1047 § 3. Amended Stats 1988 ch 581 § 3; Stats 1990 ch 1183 § 1 (AB 2226); Stats 2003 ch 439 § 1 (AB 984), operative July 1, 2004; Stats 2010 ch 543 § 7 (AB 2111), effective January 1, 2011.

**§ 1794.5. Alternative suggestions for repair of item under express warranty**

The provisions of this chapter shall not preclude a manufacturer making express warranties from suggesting methods of effecting service and repair, in accordance with the terms and conditions of the express warranties, other than those required by this chapter.

Added Stats 1970 ch 1333 § 1.

**§ 1795. Liability of nonmanufacturer making express warranty**

If express warranties are made by persons other than the manufacturer of the goods, the obligation of the person making such warranties shall be the same as that imposed on the manufacturer under this chapter.

Added Stats 1970 ch 1333 § 1.

**§ 1795.1. Application of chapter to components of air conditioning system**

This chapter shall apply to any equipment or mechanical, electrical, or thermal component of a system designed to heat, cool, or otherwise condition air, but, with that exception, shall not apply to the system as a whole where such a system becomes a fixed part of a structure.

Added Stats 1971 ch 1523 § 16.5, operative January 1, 1972. Amended Stats 1978 ch 991 § 11; Stats 1983 ch 728 § 1.

**§ 1795.5. Obligations of distributors or sellers of used goods**

Notwithstanding the provisions of subdivision (a) of Section 1791 defining consumer goods to mean “new” goods, the obligation of a distributor or retail seller of used consumer goods in a sale in which an express warranty is given shall be the same as that imposed on manufacturers under this chapter except:

(a) It shall be the obligation of the distributor or retail seller making express warranties with respect to used consumer goods (and not the original manufacturer, distributor, or retail seller making express warranties with respect to such goods when new) to maintain sufficient service and repair facilities within this state to carry out the terms of such express warranties.

(b) The provisions of Section 1793.5 shall not apply to the sale of used consumer goods sold in this state.

(c) The duration of the implied warranty of merchantability and where present the implied warranty of fitness with respect to used consumer goods sold in this state, where the sale is accompanied by an express warranty, shall be coextensive in duration with an express warranty which accompanies the consumer goods, provided the duration of the express warranty is reasonable, but in no event shall such implied warranties have a duration of less than 30 days nor more than three months following the sale of used consumer goods to a retail buyer. Where no duration for an express warranty is stated with respect to such goods, or parts thereof, the duration of the implied warranties shall be the maximum period prescribed above.

(d) The obligation of the distributor or retail seller who makes express warranties with respect to used goods that are sold in this state, shall extend to the sale of all such used goods, regardless of when such goods may have been manufactured.

Added Stats 1971 ch 1523 § 17, operative January 1, 1972. Amended Stats 1974 ch 169 § 1; Stats 1978 ch 991 § 12; Stats 1983 ch 728 § 2.

**§ 1795.6. Tolling the warranty period**

(a) Every warranty period relating to an implied or express warranty accompanying a sale or consignment for sale of consumer goods selling for fifty dollars (\$50) or more shall automatically be tolled for the period from the date upon which the buyer either (1) delivers nonconforming goods to the manufacturer or seller for warranty repairs or service or (2), pursuant to subdivision (c) of Section 1793.2 or Section 1793.22, notifies the manufacturer or seller of the nonconformity of the goods up to, and including, the date upon which (1) the repaired or

serviced goods are delivered to the buyer, (2) the buyer is notified the goods are repaired or serviced and are available for the buyer’s possession or (3) the buyer is notified that repairs or service is completed, if repairs or service is made at the buyer’s residence.

(b) Notwithstanding the date or conditions set for the expiration of the warranty period, such warranty period shall not be deemed expired if either or both of the following situations occur: (1) after the buyer has satisfied the requirements of subdivision (a), the warranty repairs or service has not been performed due to delays caused by circumstances beyond the control of the buyer or (2) the warranty repairs or service performed upon the nonconforming goods did not remedy the nonconformity for which such repairs or service was performed and the buyer notified the manufacturer or seller of this failure within 60 days after the repairs or service was completed. When the warranty repairs or service has been performed so as to remedy the nonconformity, the warranty period shall expire in accordance with its terms, including any extension to the warranty period for warranty repairs or service.

(c) For purposes of this section only, “manufacturer” includes the manufacturer’s service or repair facility.

(d) Every manufacturer or seller of consumer goods selling for fifty dollars (\$50) or more shall provide a receipt to the buyer showing the date of purchase. Every manufacturer or seller performing warranty repairs or service on the goods shall provide to the buyer a work order or receipt with the date of return and either the date the buyer was notified that the goods were repaired or serviced or, where applicable, the date the goods were shipped or delivered to the buyer.

Added Stats 1974 ch 844 § 1, operative July 1, 1975. Amended Stats 1980 ch 394 § 2; Stats 1983 ch 728 § 3; Stats 1992 ch 1232 § 10 (SB 1762).

**§ 1795.7. Effect of tolling on manufacturer’s liability**

Whenever a warranty, express or implied, is tolled pursuant to Section 1795.6 as a result of repairs or service performed by any retail seller, the warranty shall be extended with regard to the liability of the manufacturer to a retail seller pursuant to law. In such event, the manufacturer shall be liable in accordance with the provisions of Section 1793.5 for the period that an express warranty has been extended by virtue of Section 1795.6 to every retail seller who incurs obligations in giving effect to such express warranty. The manufacturer shall also be liable to every retail seller for the period that an implied warranty has been extended by virtue of Section 1795.6, in the same manner as he would be liable under Section 1793.5 for an express warranty. If a manufacturer provides for warranty repairs and service through its own service and repair facilities and through independent repair facilities in the state, its exclusive liability pursuant to this section shall be to such facilities.

Added Stats 1974 ch 844 § 2, operative July 1, 1975.

# FAMILY CODE

## DIVISION 17

### Support Services

#### CHAPTER 2

#### Child Support Enforcement

Section

17520. Consolidated lists of persons; License renewals; Review procedures; Report to Legislature; Rules and regulations; Forms; Use of information; Suspension or revocation of driver's license; Severability

#### ARTICLE 2

#### Collections and Enforcement

**§ 17520. Consolidated lists of persons; License renewals; Review procedures; Report to Legislature; Rules and regulations; Forms; Use of information; Suspension or revocation of driver's license; Severability**

(a) As used in this section:

(1) "Applicant" means any person applying for issuance or renewal of a license.

(2) "Board" means any entity specified in Section 101 of the Business and Professions Code, the entities referred to in Sections 1000 and 3600 of the Business and Professions Code, the State Bar, the Bureau of Real Estate, the Department of Motor Vehicles, the Secretary of State, the Department of Fish and Game, and any other state commission, department, committee, examiner, or agency that issues a license, certificate, credential, permit, registration, or any other authorization to engage in a business, occupation, or profession, or to the extent required by federal law or regulations, for recreational purposes. This term includes all boards, commissions, departments, committees, examiners, entities, and agencies that issue a license, certificate, credential, permit, registration, or any other authorization to engage in a business, occupation, or profession. The failure to specifically name a particular board, commission, department, committee, examiner, entity, or agency that issues a license, certificate, credential, permit, registration, or any other authorization to engage in a business, occupation, or profession does not exclude that board, commission, department, committee, examiner, entity, or agency from this term.

(3) "Certified list" means a list provided by the local child support agency to the Department of Child Support Services in which the local child support agency verifies, under penalty of perjury, that the names contained therein are support obligors found to be out of compliance with a judgment or order for support in a case being enforced under Title IV-D of the Social Security Act.

(4) "Compliance with a judgment or order for support" means that, as set forth in a judgment or order for child or family support, the obligor is no more than 30 calen-

dar days in arrears in making payments in full for current support, in making periodic payments in full, whether court ordered or by agreement with the local child support agency, on a support arrearage, or in making periodic payments in full, whether court ordered or by agreement with the local child support agency, on a judgment for reimbursement for public assistance, or has obtained a judicial finding that equitable estoppel as provided in statute or case law precludes enforcement of the order. The local child support agency is authorized to use this section to enforce orders for spousal support only when the local child support agency is also enforcing a related child support obligation owed to the obligee parent by the same obligor, pursuant to Sections 17400 and 17604.

(5) "License" includes membership in the State Bar, and a certificate, credential, permit, registration, or any other authorization issued by a board that allows a person to engage in a business, occupation, or profession, or to operate a commercial motor vehicle, including appointment and commission by the Secretary of State as a notary public. "License" also includes any driver's license issued by the Department of Motor Vehicles, any commercial fishing license issued by the Department of Fish and Game, and to the extent required by federal law or regulations, any license used for recreational purposes. This term includes all licenses, certificates, credentials, permits, registrations, or any other authorization issued by a board that allows a person to engage in a business, occupation, or profession. The failure to specifically name a particular type of license, certificate, credential, permit, registration, or other authorization issued by a board that allows a person to engage in a business, occupation, or profession, does not exclude that license, certificate, credential, permit, registration, or other authorization from this term.

(6) "Licensee" means any person holding a license, certificate, credential, permit, registration, or other authorization issued by a board, to engage in a business, occupation, or profession, or a commercial driver's license as defined in Section 15210 of the Vehicle Code, including an appointment and commission by the Secretary of State as a notary public. "Licensee" also means any person holding a driver's license issued by the Department of Motor Vehicles, any person holding a commercial fishing license issued by the Department of Fish and Game, and to the extent required by federal law or regulations, any person holding a license used for recreational purposes. This term includes all persons holding a license, certificate, credential, permit, registration, or any other authorization to engage in a business, occupation, or profession, and the failure to specifically name a particular type of license, certificate, credential, permit, registration, or other authorization issued by a

board does not exclude that person from this term. For licenses issued to an entity that is not an individual person, "licensee" includes any individual who is either listed on the license or who qualifies for the license.

(b) The local child support agency shall maintain a list of those persons included in a case being enforced under Title IV-D of the Social Security Act against whom a support order or judgment has been rendered by, or registered in, a court of this state, and who are not in compliance with that order or judgment. The local child support agency shall submit a certified list with the names, social security numbers, and last known addresses of these persons and the name, address, and telephone number of the local child support agency who certified the list to the department. The local child support agency shall verify, under penalty of perjury, that the persons listed are subject to an order or judgment for the payment of support and that these persons are not in compliance with the order or judgment. The local child support agency shall submit to the department an updated certified list on a monthly basis.

(c) The department shall consolidate the certified lists received from the local child support agencies and, within 30 calendar days of receipt, shall provide a copy of the consolidated list to each board that is responsible for the regulation of licenses, as specified in this section.

(d) On or before November 1, 1992, or as soon thereafter as economically feasible, as determined by the department, all boards subject to this section shall implement procedures to accept and process the list provided by the department, in accordance with this section. Notwithstanding any other law, all boards shall collect social security numbers from all applicants for the purposes of matching the names of the certified list provided by the department to applicants and licensees and of responding to requests for this information made by child support agencies.

(e)(1) Promptly after receiving the certified consolidated list from the department, and prior to the issuance or renewal of a license, each board shall determine whether the applicant is on the most recent certified consolidated list provided by the department. The board shall have the authority to withhold issuance or renewal of the license of any applicant on the list.

(2) If an applicant is on the list, the board shall immediately serve notice as specified in subdivision (f) on the applicant of the board's intent to withhold issuance or renewal of the license. The notice shall be made personally or by mail to the applicant's last known mailing address on file with the board. Service by mail shall be complete in accordance with Section 1013 of the Code of Civil Procedure.

(A) The board shall issue a temporary license valid for a period of 150 days to any applicant whose name is on the certified list if the applicant is otherwise eligible for a license.

(B) Except as provided in subparagraph (D), the 150-day time period for a temporary license shall not be extended. Except as provided in subparagraph (D), only one temporary license shall be issued during a regular license term and it shall coincide with the first 150 days of that license term. As this paragraph applies to commercial driver's licenses, "license term" shall be deemed to be 12 months from the date the application fee is

received by the Department of Motor Vehicles. A license for the full or remainder of the license term shall be issued or renewed only upon compliance with this section.

(C) In the event that a license or application for a license or the renewal of a license is denied pursuant to this section, any funds paid by the applicant or licensee shall not be refunded by the board.

(D) This paragraph shall apply only in the case of a driver's license, other than a commercial driver's license. Upon the request of the local child support agency or by order of the court upon a showing of good cause, the board shall extend a 150-day temporary license for a period not to exceed 150 extra days.

(3)(A) The department may, when it is economically feasible for the department and the boards to do so as determined by the department, in cases where the department is aware that certain child support obligors listed on the certified lists have been out of compliance with a judgment or order for support for more than four months, provide a supplemental list of these obligors to each board with which the department has an inter-agency agreement to implement this paragraph. Upon request by the department, the licenses of these obligors shall be subject to suspension, provided that the licenses would not otherwise be eligible for renewal within six months from the date of the request by the department. The board shall have the authority to suspend the license of any licensee on this supplemental list.

(B) If a licensee is on a supplemental list, the board shall immediately serve notice as specified in subdivision (f) on the licensee that his or her license will be automatically suspended 150 days after notice is served, unless compliance with this section is achieved. The notice shall be made personally or by mail to the licensee's last known mailing address on file with the board. Service by mail shall be complete in accordance with Section 1013 of the Code of Civil Procedure.

(C) The 150-day notice period shall not be extended.

(D) In the event that any license is suspended pursuant to this section, any funds paid by the licensee shall not be refunded by the board.

(E) This paragraph shall not apply to licenses subject to annual renewal or annual fee.

(f) Notices shall be developed by each board in accordance with guidelines provided by the department and subject to approval by the department. The notice shall include the address and telephone number of the local child support agency that submitted the name on the certified list, and shall emphasize the necessity of obtaining a release from that local child support agency as a condition for the issuance, renewal, or continued valid status of a license or licenses.

(1) In the case of applicants not subject to paragraph (3) of subdivision (e), the notice shall inform the applicant that the board shall issue a temporary license, as provided in subparagraph (A) of paragraph (2) of subdivision (e), for 150 calendar days if the applicant is otherwise eligible and that upon expiration of that time period the license will be denied unless the board has received a release from the local child support agency that submitted the name on the certified list.

(2) In the case of licensees named on a supplemental list, the notice shall inform the licensee that his or her



license will continue in its existing status for no more than 150 calendar days from the date of mailing or service of the notice and thereafter will be suspended indefinitely unless, during the 150-day notice period, the board has received a release from the local child support agency that submitted the name on the certified list. Additionally, the notice shall inform the licensee that any license suspended under this section will remain so until the expiration of the remaining license term, unless the board receives a release along with applications and fees, if applicable, to reinstate the license during the license term.

(3) The notice shall also inform the applicant or licensee that if an application is denied or a license is suspended pursuant to this section, any funds paid by the applicant or licensee shall not be refunded by the board. The Department of Child Support Services shall also develop a form that the applicant shall use to request a review by the local child support agency. A copy of this form shall be included with every notice sent pursuant to this subdivision.

(g)(1) Each local child support agency shall maintain review procedures consistent with this section to allow an applicant to have the underlying arrearage and any relevant defenses investigated, to provide an applicant information on the process of obtaining a modification of a support order, or to provide an applicant assistance in the establishment of a payment schedule on arrearages if the circumstances so warrant.

(2) It is the intent of the Legislature that a court or local child support agency, when determining an appropriate payment schedule for arrearages, base its decision on the facts of the particular case and the priority of payment of child support over other debts. The payment schedule shall also recognize that certain expenses may be essential to enable an obligor to be employed. Therefore, in reaching its decision, the court or the local child support agency shall consider both of these goals in setting a payment schedule for arrearages.

(h) If the applicant wishes to challenge the submission of his or her name on the certified list, the applicant shall make a timely written request for review to the local child support agency who certified the applicant's name. A request for review pursuant to this section shall be resolved in the same manner and timeframe provided for resolution of a complaint pursuant to Section 17800. The local child support agency shall immediately send a release to the appropriate board and the applicant, if any of the following conditions are met:

(1) The applicant is found to be in compliance or negotiates an agreement with the local child support agency for a payment schedule on arrearages or reimbursement.

(2) The applicant has submitted a request for review, but the local child support agency will be unable to complete the review and send notice of its findings to the applicant within the time specified in Section 17800.

(3) The applicant has filed and served a request for judicial review pursuant to this section, but a resolution of that review will not be made within 150 days of the date of service of notice pursuant to subdivision (f). This paragraph applies only if the delay in completing the judicial review process is not the result of the applicant's failure to act in a reasonable, timely, and diligent man-

ner upon receiving the local child support agency's notice of findings.

(4) The applicant has obtained a judicial finding of compliance as defined in this section.

(i) An applicant is required to act with diligence in responding to notices from the board and the local child support agency with the recognition that the temporary license will lapse or the license suspension will go into effect after 150 days and that the local child support agency and, where appropriate, the court must have time to act within that period. An applicant's delay in acting, without good cause, which directly results in the inability of the local child support agency to complete a review of the applicant's request or the court to hear the request for judicial review within the 150-day period shall not constitute the diligence required under this section which would justify the issuance of a release.

(j) Except as otherwise provided in this section, the local child support agency shall not issue a release if the applicant is not in compliance with the judgment or order for support. The local child support agency shall notify the applicant in writing that the applicant may, by filing an order to show cause or notice of motion, request any or all of the following:

(1) Judicial review of the local child support agency's decision not to issue a release.

(2) A judicial determination of compliance.

(3) A modification of the support judgment or order.

The notice shall also contain the name and address of the court in which the applicant shall file the order to show cause or notice of motion and inform the applicant that his or her name shall remain on the certified list if the applicant does not timely request judicial review. The applicant shall comply with all statutes and rules of court regarding orders to show cause and notices of motion.

This section shall not be deemed to limit an applicant from filing an order to show cause or notice of motion to modify a support judgment or order or to fix a payment schedule on arrearages accruing under a support judgment or order or to obtain a court finding of compliance with a judgment or order for support.

(k) The request for judicial review of the local child support agency's decision shall state the grounds for which review is requested and judicial review shall be limited to those stated grounds. The court shall hold an evidentiary hearing within 20 calendar days of the filing of the request for review. Judicial review of the local child support agency's decision shall be limited to a determination of each of the following issues:

(1) Whether there is a support judgment, order, or payment schedule on arrearages or reimbursement.

(2) Whether the petitioner is the obligor covered by the support judgment or order.

(3) Whether the support obligor is or is not in compliance with the judgment or order of support.

(4)(A) The extent to which the needs of the obligor, taking into account the obligor's payment history and the current circumstances of both the obligor and the obligee, warrant a conditional release as described in this subdivision.

(B) The request for judicial review shall be served by the applicant upon the local child support agency that submitted the applicant's name on the certified list

within seven calendar days of the filing of the petition. The court has the authority to uphold the action, unconditionally release the license, or conditionally release the license.

(C) If the judicial review results in a finding by the court that the obligor is in compliance with the judgment or order for support, the local child support agency shall immediately send a release in accordance with subdivision (l) to the appropriate board and the applicant. If the judicial review results in a finding by the court that the needs of the obligor warrant a conditional release, the court shall make findings of fact stating the basis for the release and the payment necessary to satisfy the unrestricted issuance or renewal of the license without prejudice to a later judicial determination of the amount of support arrearages, including interest, and shall specify payment terms, compliance with which are necessary to allow the release to remain in effect.

(l) The department shall prescribe release forms for use by local child support agencies. When the obligor is in compliance, the local child support agency shall mail to the applicant and the appropriate board a release stating that the applicant is in compliance. The receipt of a release shall serve to notify the applicant and the board that, for the purposes of this section, the applicant is in compliance with the judgment or order for support. Any board that has received a release from the local child support agency pursuant to this subdivision shall process the release within five business days of its receipt.

If the local child support agency determines subsequent to the issuance of a release that the applicant is once again not in compliance with a judgment or order for support, or with the terms of repayment as described in this subdivision, the local child support agency may notify the board, the obligor, and the department in a format prescribed by the department that the obligor is not in compliance.

The department may, when it is economically feasible for the department and the boards to develop an automated process for complying with this subdivision, notify the boards in a manner prescribed by the department, that the obligor is once again not in compliance. Upon receipt of this notice, the board shall immediately notify the obligor on a form prescribed by the department that the obligor's license will be suspended on a specific date, and this date shall be no longer than 30 days from the date the form is mailed. The obligor shall be further notified that the license will remain suspended until a new release is issued in accordance with subdivision (h). Nothing in this section shall be deemed to limit the obligor from seeking judicial review of suspension pursuant to the procedures described in subdivision (k).

(m) The department may enter into interagency agreements with the state agencies that have responsibility for the administration of boards necessary to implement this section, to the extent that it is cost effective to implement this section. These agreements shall provide for the receipt by the other state agencies and boards of federal funds to cover that portion of costs allowable in federal law and regulation and incurred by the state agencies and boards in implementing this section. Notwithstanding any other provision of law, revenue generated by a board or state agency shall be used to fund the nonfederal share of costs incurred

pursuant to this section. These agreements shall provide that boards shall reimburse the department for the nonfederal share of costs incurred by the department in implementing this section. The boards shall reimburse the department for the nonfederal share of costs incurred pursuant to this section from moneys collected from applicants and licensees.

(n) Notwithstanding any other law, in order for the boards subject to this section to be reimbursed for the costs incurred in administering its provisions, the boards may, with the approval of the appropriate department director, levy on all licensees and applicants a surcharge on any fee or fees collected pursuant to law, or, alternatively, with the approval of the appropriate department director, levy on the applicants or licensees named on a certified list or supplemental list, a special fee.

(o) The process described in subdivision (h) shall constitute the sole administrative remedy for contesting the issuance of a temporary license or the denial or suspension of a license under this section. The procedures specified in the administrative adjudication provisions of the Administrative Procedure Act (Chapter 4.5 (commencing with Section 11400) and Chapter 5 (commencing with Section 11500) of Part 1 of Division 3 of Title 2 of the Government Code) shall not apply to the denial, suspension, or failure to issue or renew a license or the issuance of a temporary license pursuant to this section.

(p) In furtherance of the public policy of increasing child support enforcement and collections, on or before November 1, 1995, the State Department of Social Services shall make a report to the Legislature and the Governor based on data collected by the boards and the district attorneys in a format prescribed by the State Department of Social Services. The report shall contain all of the following:

(1) The number of delinquent obligors certified by district attorneys under this section.

(2) The number of support obligors who also were applicants or licensees subject to this section.

(3) The number of new licenses and renewals that were delayed, temporary licenses issued, and licenses suspended subject to this section and the number of new licenses and renewals granted and licenses reinstated following board receipt of releases as provided by subdivision (h) by May 1, 1995.

(4) The costs incurred in the implementation and enforcement of this section.

(q) Any board receiving an inquiry as to the licensed status of an applicant or licensee who has had a license denied or suspended under this section or has been granted a temporary license under this section shall respond only that the license was denied or suspended or the temporary license was issued pursuant to this section. Information collected pursuant to this section by any state agency, board, or department shall be subject to the Information Practices Act of 1977 (Chapter 1 (commencing with Section 1798) of Title 1.8 of Part 4 of Division 3 of the Civil Code).

(r) Any rules and regulations issued pursuant to this section by any state agency, board, or department may be adopted as emergency regulations in accordance with the rulemaking provisions of the Administrative Procedure Act (Chapter 3.5 (commencing with Section 11340) of Part 1 of Division 3 of Title 2 of the Government Code).

The adoption of these regulations shall be deemed an emergency and necessary for the immediate preservation of the public peace, health, and safety, or general welfare. The regulations shall become effective immediately upon filing with the Secretary of State.

(s) The department and boards, as appropriate, shall adopt regulations necessary to implement this section.

(t) The Judicial Council shall develop the forms necessary to implement this section, except as provided in subdivisions (f) and (l).

(u) The release or other use of information received by a board pursuant to this section, except as authorized by this section, is punishable as a misdemeanor.

(v) The State Board of Equalization shall enter into interagency agreements with the department and the Franchise Tax Board that will require the department and the Franchise Tax Board to maximize the use of information collected by the State Board of Equalization, for child support enforcement purposes, to the extent it is cost effective and permitted by the Revenue and Taxation Code.

(w)(1) The suspension or revocation of any driver's license, including a commercial driver's license, under this section shall not subject the licensee to vehicle impoundment pursuant to Section 14602.6 of the Vehicle Code.

(2) Notwithstanding any other law, the suspension or revocation of any driver's license, including a commercial driver's license, under this section shall not subject the licensee to increased costs for vehicle liability insurance.

(x) If any provision of this section or the application thereof to any person or circumstance is held invalid, that invalidity shall not affect other provisions or applications of this section which can be given effect without the invalid provision or application, and to this end the provisions of this section are severable.

(y) All rights to administrative and judicial review afforded by this section to an applicant shall also be afforded to a licensee.

Added Stats 1999 ch 654 § 3.5 (AB 370). Amended Stats 2001 ch 755 § 14 (SB 943), effective October 12, 2001; Stats 2013 ch 352 § 79 (AB 1317), effective September 26, 2013, operative July 1, 2013.

# GOVERNMENT CODE

## TITLE 1 GENERAL

### DIVISION 4 Public Officers and Employees

#### CHAPTER 9.7 Public Safety Officers

Section

3309.5. Proceeding for violations of rights and protections; Jurisdiction; Relief; Frivolous actions; Civil penalty; Actual damages

**§ 3309.5. Proceeding for violations of rights and protections; Jurisdiction; Relief; Frivolous actions; Civil penalty; Actual damages**

(a) It shall be unlawful for any public safety department to deny or refuse to any public safety officer the rights and protections guaranteed to him or her by this chapter.

(b) Nothing in subdivision (h) of Section 11181 shall be construed to affect the rights and protections afforded to state public safety officers under this chapter or under Section 832.5 of the Penal Code.

(c) The superior court shall have initial jurisdiction over any proceeding brought by any public safety officer against any public safety department for alleged violations of this chapter.

(d)(1) In any case where the superior court finds that a public safety department has violated any of the provisions of this chapter, the court shall render appropriate injunctive or other extraordinary relief to remedy the violation and to prevent future violations of a like or similar nature, including, but not limited to, the granting of a temporary restraining order, preliminary injunction, or permanent injunction prohibiting the public safety department from taking any punitive action against the public safety officer.

(2) If the court finds that a bad faith or frivolous action or a filing for an improper purpose has been brought pursuant to this chapter, the court may order sanctions against the party filing the action, the party's attorney, or both, pursuant to Sections 128.6 and 128.7 of the Code of Civil Procedure. Those sanctions may include, but not be limited to, reasonable expenses, including attorney's fees, incurred by a public safety department as the court deems appropriate. Nothing in this paragraph is intended to subject actions or filings under this section to rules or standards that are different from those applicable to other civil actions or filings subject to Section 128.6 or 128.7 of the Code of Civil Procedure.

(e) In addition to the extraordinary relief afforded by this chapter, upon a finding by a superior court that a public safety department, its employees, agents, or assigns, with respect to acts taken within the scope of

employment, maliciously violated any provision of this chapter with the intent to injure the public safety officer, the public safety department shall, for each and every violation, be liable for a civil penalty not to exceed twenty-five thousand dollars (\$25,000) to be awarded to the public safety officer whose right or protection was denied and for reasonable attorney's fees as may be determined by the court. If the court so finds, and there is sufficient evidence to establish actual damages suffered by the officer whose right or protection was denied, the public safety department shall also be liable for the amount of the actual damages. Notwithstanding these provisions, a public safety department may not be required to indemnify a contractor for the contractor's liability pursuant to this subdivision if there is, within the contract between the public safety department and the contractor, a "hold harmless" or similar provision that protects the public safety department from liability for the actions of the contractor. An individual shall not be liable for any act for which a public safety department is liable under this section.

Added Stats 1979 ch 405 § 1. Amended Stats 1980 ch 1367 § 1; Stats 1997 ch 148 § 2 (AB 1436); Stats 2002 ch 1156 § 1 (SB 1516); Stats 2003 ch 62 § 103 (SB 600), ch 876 § 4 (SB 434) (ch 876 prevails); Stats 2005 ch 22 § 70 (SB 1108), effective January 1, 2006.

### DIVISION 7 Miscellaneous

#### CHAPTER 3.5 Inspection of Public Records

#### ARTICLE 1 General Provisions

Section

6250. Legislative finding and declaration

6251. Citation of chapter

6252. Definitions

6252.5. Elected member or officer's access to public records

6253. Time for inspection of public records; "Unusual circumstances"

6253.1. Agency to assist in inspection of public record

6253.2. (First of two; Operative term contingent) Disclosure of information for in-home supportive services, personal care services, or Community First Choice Option

6253.2. (Second of two; Operative date contingent) Disclosure of information for in-home supportive services or personal care services

6253.3. Control of disclosure by another party

6253.31. Contract of state or local agency requiring private entity to review, audit or report on agency

6253.4. Records to be made available

6253.9. Information in electronic format

6254. Records exempt from disclosure requirements

**§ 6250. Legislative finding and declaration**

In enacting this chapter, the Legislature, mindful of the right of individuals to privacy, finds and declares that access to information concerning the conduct of the people's business is a fundamental and necessary right of every person in this state.

Added Stats 1968 ch 1473 § 39. Amended Stats 1970 ch 575 § 1.

**§ 6251. Citation of chapter**

This chapter shall be known and may be cited as the California Public Records Act.

Added Stats 1968 ch 1473 § 39.

**§ 6252. Definitions**

As used in this chapter:

(a) "Local agency" includes a county; city, whether general law or chartered; city and county; school district; municipal corporation; district; political subdivision; or any board, commission or agency thereof; other local public agency; or entities that are legislative bodies of a local agency pursuant to subdivisions (c) and (d) of Section 54952.

(b) "Member of the public" means any person, except a member, agent, officer, or employee of a federal, state, or local agency acting within the scope of his or her membership, agency, office, or employment.

(c) "Person" includes any natural person, corporation, partnership, limited liability company, firm, or association.

(d) "Public agency" means any state or local agency.

(e) "Public records" includes any writing containing information relating to the conduct of the public's business prepared, owned, used, or retained by any state or local agency regardless of physical form or characteristics. "Public records" in the custody of, or maintained by, the Governor's office means any writing prepared on or after January 6, 1975.

(f) "State agency" means every state office, officer, department, division, bureau, board, and commission or other state body or agency, except those agencies provided for in Article IV (except Section 20 thereof) or Article VI of the California Constitution.

(g) "Writing" means any handwriting, typewriting, printing, photostating, photographing, photocopying, transmitting by electronic mail or facsimile, and every other means of recording upon any tangible thing any form of communication or representation, including letters, words, pictures, sounds, or symbols, or combinations thereof, and any record thereby created, regardless of the manner in which the record has been stored.

Added Stats 1968 ch 1473 § 39. Amended Stats 1970 ch 575 § 2; Stats 1975 ch 1246 § 2; Stats 1981 ch 968 § 1; Stats 1991 ch 181 § 1 (AB 788); Stats 1994 ch 1010 § 136 (SB 2053); Stats 1998 ch 620 § 2 (SB 143); Stats 2002 ch 945 § 2.5 (AB 1962), ch 1073 § 1.5 (AB 2937); Stats 2004 ch 937 § 1 (AB 1933).

**§ 6252.5. Elected member or officer's access to public records**

Notwithstanding the definition of "member of the public" in Section 6252, an elected member or officer of any state or local agency is entitled to access to public records of that agency on the same basis as any other person. Nothing in this section shall limit the ability of

elected members or officers to access public records permitted by law in the administration of their duties.

This section does not constitute a change in, but is declaratory of, existing law.

Added Stats 1998 ch 620 § 3 (SB 143).

**§ 6253. Time for inspection of public records; "Unusual circumstances"**

(a) Public records are open to inspection at all times during the office hours of the state or local agency and every person has a right to inspect any public record, except as hereafter provided. Any reasonably segregable portion of a record shall be available for inspection by any person requesting the record after deletion of the portions that are exempted by law.

(b) Except with respect to public records exempt from disclosure by express provisions of law, each state or local agency, upon a request for a copy of records that reasonably describes an identifiable record or records, shall make the records promptly available to any person upon payment of fees covering direct costs of duplication, or a statutory fee if applicable. Upon request, an exact copy shall be provided unless impracticable to do so.

(c) Each agency, upon a request for a copy of records, shall, within 10 days from receipt of the request, determine whether the request, in whole or in part, seeks copies of disclosable public records in the possession of the agency and shall promptly notify the person making the request of the determination and the reasons therefor. In unusual circumstances, the time limit prescribed in this section may be extended by written notice by the head of the agency or his or her designee to the person making the request, setting forth the reasons for the extension and the date on which a determination is expected to be dispatched. No notice shall specify a date that would result in an extension for more than 14 days. When the agency dispatches the determination, and if the agency determines that the request seeks disclosable public records, the agency shall state the estimated date and time when the records will be made available. As used in this section, "unusual circumstances" means the following, but only to the extent reasonably necessary to the proper processing of the particular request:

(1) The need to search for and collect the requested records from field facilities or other establishments that are separate from the office processing the request.

(2) The need to search for, collect, and appropriately examine a voluminous amount of separate and distinct records that are demanded in a single request.

(3) The need for consultation, which shall be conducted with all practicable speed, with another agency having substantial interest in the determination of the request or among two or more components of the agency having substantial subject matter interest therein.

(4) The need to compile data, to write programming language or a computer program, or to construct a computer report to extract data.

(d) Nothing in this chapter shall be construed to permit an agency to delay or obstruct the inspection or copying of public records. The notification of denial of any request for records required by Section 6255 shall set forth the names and titles or positions of each person responsible for the denial.

(e) Except as otherwise prohibited by law, a state or local agency may adopt requirements for itself that allow for faster, more efficient, or greater access to records than prescribed by the minimum standards set forth in this chapter.

Added Stats 1998 ch 620 § 5 (SB 143). Amended Stats 1999 ch 83 § 64 (SB 966); Stats 2000 ch 982 § 1 (AB 2799); Stats 2001 ch 355 § 2 (AB 1014).

**§ 6253.1. Agency to assist in inspection of public record**

(a) When a member of the public requests to inspect a public record or obtain a copy of a public record, the public agency, in order to assist the member of the public make a focused and effective request that reasonably describes an identifiable record or records, shall do all of the following, to the extent reasonable under the circumstances:

(1) Assist the member of the public to identify records and information that are responsive to the request or to the purpose of the request, if stated.

(2) Describe the information technology and physical location in which the records exist.

(3) Provide suggestions for overcoming any practical basis for denying access to the records or information sought.

(b) The requirements of paragraph (1) of subdivision (a) shall be deemed to have been satisfied if the public agency is unable to identify the requested information after making a reasonable effort to elicit additional clarifying information from the requester that will help identify the record or records.

(c) The requirements of subdivision (a) are in addition to any action required of a public agency by Section 6253.

(d) This section shall not apply to a request for public records if any of the following applies:

(1) The public agency makes available the requested records pursuant to Section 6253.

(2) The public agency determines that the request should be denied and bases that determination solely on an exemption listed in Section 6254.

(3) The public agency makes available an index of its records.

Added Stats 2001 ch 355 § 3 (AB 1014).

**§ 6253.2. (First of two; Operative term contingent) Disclosure of information for in-home supportive services, personal care services, or Community First Choice Option**

(a) Notwithstanding any other provision of this chapter to the contrary, information regarding persons paid by the state to provide in-home supportive services pursuant to Article 7 (commencing with Section 12300) of Chapter 3 of Part 3 of Division 9 of the Welfare and Institutions Code, or services provided pursuant to Section 14132.95, 14132.952, or 14132.956 of the Welfare and Institutions Code, is not subject to public disclosure pursuant to this chapter, except as provided in subdivision (b).

(b) Copies of names, addresses, and telephone numbers of persons described in subdivision (a) shall be made available, upon request, to an exclusive bargaining agent and to any labor organization seeking representation rights pursuant to Section 12301.6 or 12302.25 of the

Welfare and Institutions Code or the In-Home Supportive Services Employer-Employee Relations Act (Title 23 (commencing with Section 110000)). This information shall not be used by the receiving entity for any purpose other than the employee organizing, representation, and assistance activities of the labor organization.

(c) This section applies solely to individuals who provide services under the In-Home Supportive Services Program (Article 7 (commencing with Section 12300) of Chapter 3 of Part 3 of Division 9 of the Welfare and Institutions Code), the Personal Care Services Program pursuant to Section 14132.95 of the Welfare and Institutions Code, the In-Home Supportive Services Plus Option pursuant to Section 14132.952 of the Welfare and Institutions Code, or the Community First Choice Option pursuant to Section 14132.956 of the Welfare and Institutions Code.

(d) Nothing in this section is intended to alter or shall be interpreted to alter the rights of parties under the In-Home Supportive Services Employer-Employee Relations Act (Title 23 (commencing with Section 110000)) or any other labor relations law.

(e) This section shall be inoperative if the Coordinated Care Initiative becomes inoperative pursuant to Section 34 of the act that added this subdivision.

Added Stats 1999 ch 804 § 1 (AB 515), effective October 10, 1999. Amended Stats 2012 ch 45 § 1 (SB 1036), effective June 27, 2012, ch 439 § 2 (AB 1471), effective September 22, 2012; Stats 2013 ch 37 § 1 (SB 94), effective June 27, 2013.

**Editor's Notes**—The 2012 Note to Stats 2012 ch 45 § 15 under this section, specifying this section to become inoperative under certain conditions, was repealed by Stats 2013 ch 37 § 31, effective June 27, 2013.

**Note**—Stats 2012 ch 45 provides:

SEC. 20. This act shall become operative only if Assembly Bill 1468 or Senate Bill 1008 of the 2011-12 Regular Session of the Legislature is enacted and takes effect.

Stats 2013 ch 37 provides:

SEC. 34. (a) At least 30 days prior to enrollment of beneficiaries into the Coordinated Care Initiative, the Director of Finance shall estimate the amount of net General Fund savings obtained from the implementation of the Coordinated Care Initiative. This estimate shall take into account any net savings to the General Fund achieved through the tax imposed pursuant to Article 5 (commencing with Section 6174) of Chapter 2 of Part 1 of Division 2 of the Revenue and Taxation Code Article 5 (commencing with Section 6174).

(b)(1) By January 10 for each fiscal year after implementation of the Coordinated Care Initiative, for as long as the Coordinated Care Initiative remains operative, the Director of Finance shall estimate the amount of net General Fund savings obtained from the implementation of the Coordinated Care Initiative.

(2) Savings shall be determined under this subdivision by comparing the estimated costs of the Coordinated Care Initiative, as approved by the federal government, and the estimated costs of the program if the Coordinated Care Initiative were not operative. The determination shall also include any net savings to the General Fund achieved through the tax imposed pursuant to Article 5 (commencing with Section 6174) of Chapter 2 of Part 1 of Division 2 of the Revenue and Taxation Code.

(3) The estimates prepared by the Director of Finance, in consultation with the Director of Health Care Services, shall be provided to the Legislature.

(c)(1) Notwithstanding any other law, if, at least 30 days prior to enrollment of beneficiaries into the Coordinated Care Initiative, the Director of Finance estimates pursuant to subdivision (a) that the Coordinated Care Initiative will not generate net General Fund savings, then the activities to implement the Coordinated Care Initiative shall be suspended immediately and the Coordinated Care Initiative shall become inoperative July 1, 2014.

(2) If the Coordinated Care Initiative becomes inoperative pursuant to this subdivision, the Director of Health Care Services shall provide any necessary notifications to any affected entities.

(3) For purposes of this subdivision and subdivision (d) only, “Coordinated Care Initiative” means all of the following statutes and any amendments to the following:

(A) Sections 14132.275, 14183.6, and 14301.1 of the Welfare and Institutions Code, as amended by this act.

(B) Sections 14132.276, 14132.277, 14182.16, 14182.17, 14182.18, and 14301.2 of the Welfare and Institutions Code.

(C) Article 5.7 (commencing with Section 14186) of Chapter 7 of Part 3 of Division 9 of the Welfare and Institutions Code.

(D) Title 23 (commencing with Section 110000) of the Government Code.

(E) Section 6531.5 of the Government Code.

(F) Section 6253.2 of the Government Code, as amended by this act.

(G) Sections 12300.5, 12300.6, 12300.7, 12302.6, 12306.15, 12330, 14186.35, and 14186.36 of the Welfare and Institutions Code.

(H) Sections 10101.1, 12306, and 12306.1 of the Welfare and Institutions Code, as amended by this act.

(I) The amendments made to Sections 12302.21 and 12302.25 of the Welfare and Institutions Code, as made by Chapter 439 of the Statutes of 2012.

(d)(1) Notwithstanding any other law, and beginning in 2015, if the Director of Finance estimates pursuant to subdivision (b) that the Coordinated Care Initiative will not generate net General Fund savings, the Coordinated Care Initiative shall become inoperative January 1 of the following calendar year, except as follows:

(A) Section 12306.15 of the Welfare and Institutions Code shall become inoperative as of July 1 of that same calendar year.

(B) For any agreement that has been negotiated and approved by the Statewide Authority, the Statewide Authority shall continue to retain its authority pursuant to Section 6531.5 and Title 23 (commencing with Section 110000) of the Government Code and Sections 12300.5, 12300.6, 12300.7, and 12302.6 of the Welfare and Institutions Code, and shall remain the employer of record for all individual providers covered by the agreement until the agreement expires or is subject to renegotiation, whereby the authority of the Statewide Authority shall terminate and the county shall be the employer of record in accordance with Section 12302.25 of the Welfare and Institutions Code and may establish an employer of record pursuant to Section 12301.6 of the Welfare and Institutions Code.

(C) For an agreement that has been assumed by the Statewide Authority that was negotiated and approved by a predecessor agency, the Statewide Authority shall cease being the employer of record and the county shall be reestablished as the employer of record for purposes of bargaining and in accordance with Section 12302.25 of the Welfare and Institutions Code, and may establish an employer of record pursuant to Section 12301.6 of the Welfare and Institutions Code.

(2) If the Coordinated Care Initiative becomes inoperative pursuant to this subdivision, the Director of Health Care Services shall provide any necessary notifications to any affected entities.

**§ 6253.2. (Second of two; Operative date contingent) Disclosure of information for in-home supportive services or personal care services**

(a) Notwithstanding any other provision of this chapter to the contrary, information regarding persons paid by the state to provide in-home supportive services pursuant to Article 7 (commencing with Section 12300) of Chapter 3 of Part 3 of Division 9 of the Welfare and Institutions Code or personal care services pursuant to Section 14132.95 of the Welfare and Institutions Code, is not subject to public disclosure pursuant to this chapter, except as provided in subdivision (b).

(b) Copies of names, addresses, and telephone numbers of persons described in subdivision (a) shall be made available, upon request, to an exclusive bargaining agent and to any labor organization seeking representation rights pursuant to subdivision (c) of Section 12301.6 or Section 12302.25 of the Welfare and Institutions Code or Chapter 10 (commencing with Section 3500) of Division 4 of Title 1. This information shall not be used by the receiving entity for any purpose other than the employee organizing, representation, and assistance activities of the labor organization.

(c) This section applies solely to individuals who provide services under the In-Home Supportive Services Program (Article 7 (commencing with Section 12300) of Chapter 3 of Part 3 of Division 9 of the Welfare and Institutions Code) or the Personal Care Services Program pursuant to Section 14132.95 of the Welfare and Institutions Code.

(d) Nothing in this section is intended to alter or shall be interpreted to alter the rights of parties under the Meyers-Milias-Brown Act (Chapter 10 (commencing with Section 3500) of Division 4) or any other labor relations law.

(e) This section shall be operative only if Section 1 of the act that added this subdivision becomes inoperative pursuant to subdivision (e) of that Section 1.

Added Stats 1999 ch 804 § 1 (AB 515), effective October 10, 1999. Amended Stats 2012 ch 439 § 1 (AB 1471), effective September 22, 2012; Stats 2013 ch 37 § 2 (SB 94), effective June 27, 2013.

**Editor’s Notes**—Stats 2013 ch 37 provides:

“SEC. 34. (a) At least 30 days prior to enrollment of beneficiaries into the Coordinated Care Initiative, the Director of Finance shall estimate the amount of net General Fund savings obtained from the implementation of the Coordinated Care Initiative. This estimate shall take into account any net savings to the General Fund achieved through the tax imposed pursuant to Article 5 (commencing with Section 6174) of Chapter 2 of Part 1 of Division 2 of the Revenue and Taxation Code Article 5 (commencing with Section 6174).

“(b)(1) By January 10 for each fiscal year after implementation of the Coordinated Care Initiative, for as long as the Coordinated Care Initiative remains operative, the Director of Finance shall estimate the amount of net General Fund savings obtained from the implementation of the Coordinated Care Initiative.

“(2) Savings shall be determined under this subdivision by comparing the estimated costs of the Coordinated Care Initiative, as approved by the federal government, and the estimated costs of the program if the Coordinated Care Initiative were not operative. The determination shall also include any net savings to the General Fund achieved through the tax imposed pursuant to Article 5 (commencing with Section 6174) of Chapter 2 of Part 1 of Division 2 of the Revenue and Taxation Code.

“(3) The estimates prepared by the Director of Finance, in consultation with the Director of Health Care Services, shall be provided to the Legislature.

“(c)(1) Notwithstanding any other law, if, at least 30 days prior to enrollment of beneficiaries into the Coordinated Care Initiative, the Director of Finance estimates pursuant to subdivision (a) that the Coordinated Care Initiative will not generate net General Fund savings, then the activities to implement the Coordinated Care Initiative shall be suspended immediately and the Coordinated Care Initiative shall become inoperative July 1, 2014.

“(2) If the Coordinated Care Initiative becomes inoperative pursuant to this subdivision, the Director of Health Care Services shall provide any necessary notifications to any affected entities.

“(3) For purposes of this subdivision and subdivision (d) only, “Coordinated Care Initiative” means all of the following statutes and any amendments to the following:

“(A) Sections 14132.275, 14183.6, and 14301.1 of the Welfare and Institutions Code, as amended by this act.

“(B) Sections 14132.276, 14132.277, 14182.16, 14182.17, 14182.18, and 14301.2 of the Welfare and Institutions Code.

“(C) Article 5.7 (commencing with Section 14186) of Chapter 7 of Part 3 of Division 9 of the Welfare and Institutions Code.

“(D) Title 23 (commencing with Section 110000) of the Government Code.

“(E) Section 6531.5 of the Government Code.

“(F) Section 6253.2 of the Government Code, as amended by this act.

“(G) Sections 12300.5, 12300.6, 12300.7, 12302.6, 12306.15, 12330, 14186.35, and 14186.36 of the Welfare and Institutions Code.

“(H) Sections 10101.1, 12306, and 12306.1 of the Welfare and Institutions Code, as amended by this act.

“(I) The amendments made to Sections 12302.21 and 12302.25 of the Welfare and Institutions Code, as made by Chapter 439 of the Statutes of 2012.

“(d)(1) Notwithstanding any other law, and beginning in 2015, if the Director of Finance estimates pursuant to subdivision (b) that the Coordinated Care Initiative will not generate net General Fund savings,

the Coordinated Care Initiative shall become inoperative January 1 of the following calendar year, except as follows:

“(A) Section 12306.15 of the Welfare and Institutions Code shall become inoperative as of July 1 of that same calendar year.

“(B) For any agreement that has been negotiated and approved by the Statewide Authority, the Statewide Authority shall continue to retain its authority pursuant to Section 6531.5 and Title 23 (commencing with Section 11000) of the Government Code and Sections 12300.5, 12300.6, 12300.7, and 12302.6 of the Welfare and Institutions Code, and shall remain the employer of record for all individual providers covered by the agreement until the agreement expires or is subject to renegotiation, whereby the authority of the Statewide Authority shall terminate and the county shall be the employer of record in accordance with Section 12302.25 of the Welfare and Institutions Code and may establish an employer of record pursuant to Section 12301.6 of the Welfare and Institutions Code.

“(C) For an agreement that has been assumed by the Statewide Authority that was negotiated and approved by a predecessor agency, the Statewide Authority shall cease being the employer of record and the county shall be reestablished as the employer of record for purposes of bargaining and in accordance with Section 12302.25 of the Welfare and Institutions Code, and may establish an employer of record pursuant to Section 12301.6 of the Welfare and Institutions Code.

“(2) If the Coordinated Care Initiative becomes inoperative pursuant to this subdivision, the Director of Health Care Services shall provide any necessary notifications to any affected entities.”

**§ 6253.3 Control of disclosure by another party**

A state or local agency may not allow another party to control the disclosure of information that is otherwise subject to disclosure pursuant to this chapter.

Added Stats 2008 ch 62 § 1 (SB 1696), effective January 1, 2009.

**§ 6253.31 Contract of state or local agency requiring private entity to review, audit or report on agency**

Notwithstanding any contract term to the contrary, a contract entered into by a state or local agency subject to this chapter, including the University of California, that requires a private entity to review, audit, or report on any aspect of that agency shall be public to the extent the contract is otherwise subject to disclosure under this chapter.

Added Stats 2008 ch 62 § 2 (SB 1696), effective January 1, 2009.

**§ 6253.4. Records to be made available**

(a) Every agency may adopt regulations stating the procedures to be followed when making its records available in accordance with this section.

The following state and local bodies shall establish written guidelines for accessibility of records. A copy of these guidelines shall be posted in a conspicuous public place at the offices of these bodies, and a copy of the guidelines shall be available upon request free of charge to any person requesting that body’s records:

- Department of Motor Vehicles
- Department of Consumer Affairs
- Transportation Agency
- Bureau of Real Estate
- Department of Corrections and Rehabilitation
- Division of Juvenile Justice
- Department of Justice
- Department of Insurance
- Department of Business Oversight
- Department of Managed Health Care
- Secretary of State
- State Air Resources Board
- Department of Water Resources
- Department of Parks and Recreation

San Francisco Bay Conservation and Development Commission

- State Board of Equalization
- State Department of Health Care Services
- Employment Development Department
- State Department of Public Health
- State Department of Social Services
- State Department of State Hospitals
- State Department of Developmental Services
- Public Employees’ Retirement System
- Teachers’ Retirement Board
- Department of Industrial Relations
- Department of General Services
- Department of Veterans Affairs
- Public Utilities Commission
- California Coastal Commission
- State Water Resources Control Board
- San Francisco Bay Area Rapid Transit District
- All regional water quality control boards
- Los Angeles County Air Pollution Control District
- Bay Area Air Pollution Control District
- Golden Gate Bridge, Highway and Transportation District

Department of Toxic Substances Control  
Office of Environmental Health Hazard Assessment

(b) Guidelines and regulations adopted pursuant to this section shall be consistent with all other sections of this chapter and shall reflect the intention of the Legislature to make the records accessible to the public. The guidelines and regulations adopted pursuant to this section shall not operate to limit the hours public records are open for inspection as prescribed in Section 6253.

Added Stats 1968 ch 1473 § 39, as Gov C § 6253. Amended Stats 1973 ch 664 § 1; Stats 1974 ch 544 § 7; Stats 1975 ch 957 § 6; Stats 1977 ch 1252 § 96, operative July 1, 1978; Stats 1979 ch 373 § 120; Stats 1983 ch 826 § 1; Stats 1988 ch 409 § 1. Supplemented by Governor’s Reorganization Plan No. 1 of 1991 § 70, effective July 17, 1991. Amended and renumbered by Stats 1998 ch 620 § 4 (SB 143). Amended Stats 1999 ch 525 § 11 (AB 78); Stats 2000 ch 857 § 9 (AB 2903); Stats 2006 ch 241 § 2 (SB 162), effective January 1, 2007, operative July 1, 2007; Stats 2012 ch 440 § 7 (AB 1488), effective September 22, 2012; Stats 2013 ch 22 § 7 (AB 75), effective June 27, 2013, operative July 1, 2013.

**§ 6253.9. Information in electronic format**

(a) Unless otherwise prohibited by law, any agency that has information that constitutes an identifiable public record not exempt from disclosure pursuant to this chapter that is in an electronic format shall make that information available in an electronic format when requested by any person and, when applicable, shall comply with the following:

(1) The agency shall make the information available in any electronic format in which it holds the information.

(2) Each agency shall provide a copy of an electronic record in the format requested if the requested format is one that has been used by the agency to create copies for its own use or for provision to other agencies. The cost of duplication shall be limited to the direct cost of producing a copy of a record in an electronic format.

(b) Notwithstanding paragraph (2) of subdivision (a), the requester shall bear the cost of producing a copy of the record, including the cost to construct a record, and the cost of programming and computer services necessary to produce a copy of the record when either of the following applies:



(1) In order to comply with the provisions of subdivision (a), the public agency would be required to produce a copy of an electronic record and the record is one that is produced only at otherwise regularly scheduled intervals.

(2) The request would require data compilation, extraction, or programming to produce the record.

(c) Nothing in this section shall be construed to require the public agency to reconstruct a record in an electronic format if the agency no longer has the record available in an electronic format.

(d) If the request is for information in other than electronic format, and the information also is in electronic format, the agency may inform the requester that the information is available in electronic format.

(e) Nothing in this section shall be construed to permit an agency to make information available only in an electronic format.

(f) Nothing in this section shall be construed to require the public agency to release an electronic record in the electronic form in which it is held by the agency if its release would jeopardize or compromise the security or integrity of the original record or of any proprietary software in which it is maintained.

(g) Nothing in this section shall be construed to permit public access to records held by any agency to which access is otherwise restricted by statute.

Added Stats 2000 ch 982 § 2 (AB 2799).

#### § 6254. Records exempt from disclosure requirements

Except as provided in Sections 6254.7 and 6254.13, nothing in this chapter shall be construed to require disclosure of records that are any of the following:

(a) Preliminary drafts, notes, or interagency or intra-agency memoranda that are not retained by the public agency in the ordinary course of business, if the public interest in withholding those records clearly outweighs the public interest in disclosure.

(b) Records pertaining to pending litigation to which the public agency is a party, or to claims made pursuant to Division 3.6 (commencing with Section 810), until the pending litigation or claim has been finally adjudicated or otherwise settled.

(c) Personnel, medical, or similar files, the disclosure of which would constitute an unwarranted invasion of personal privacy.

(d) Contained in or related to any of the following:

(1) Applications filed with any state agency responsible for the regulation or supervision of the issuance of securities or of financial institutions, including, but not limited to, banks, savings and loan associations, industrial loan companies, credit unions, and insurance companies.

(2) Examination, operating, or condition reports prepared by, on behalf of, or for the use of, any state agency referred to in paragraph (1).

(3) Preliminary drafts, notes, or interagency or intra-agency communications prepared by, on behalf of, or for the use of, any state agency referred to in paragraph (1).

(4) Information received in confidence by any state agency referred to in paragraph (1).

(e) Geological and geophysical data, plant production data, and similar information relating to utility systems

development, or market or crop reports, that are obtained in confidence from any person.

(f) Records of complaints to, or investigations conducted by, or records of intelligence information or security procedures of, the office of the Attorney General and the Department of Justice, the Office of Emergency Services and any state or local police agency, or any investigatory or security files compiled by any other state or local police agency, or any investigatory or security files compiled by any other state or local agency for correctional, law enforcement, or licensing purposes. However, state and local law enforcement agencies shall disclose the names and addresses of persons involved in, or witnesses other than confidential informants to, the incident, the description of any property involved, the date, time, and location of the incident, all diagrams, statements of the parties involved in the incident, the statements of all witnesses, other than confidential informants, to the victims of an incident, or an authorized representative thereof, an insurance carrier against which a claim has been or might be made, and any person suffering bodily injury or property damage or loss, as the result of the incident caused by arson, burglary, fire, explosion, larceny, robbery, carjacking, vandalism, vehicle theft, or a crime as defined by subdivision (b) of Section 13951, unless the disclosure would endanger the safety of a witness or other person involved in the investigation, or unless disclosure would endanger the successful completion of the investigation or a related investigation. However, nothing in this division shall require the disclosure of that portion of those investigative files that reflects the analysis or conclusions of the investigating officer.

Customer lists provided to a state or local police agency by an alarm or security company at the request of the agency shall be construed to be records subject to this subdivision.

Notwithstanding any other provision of this subdivision, state and local law enforcement agencies shall make public the following information, except to the extent that disclosure of a particular item of information would endanger the safety of a person involved in an investigation or would endanger the successful completion of the investigation or a related investigation:

(1) The full name and occupation of every individual arrested by the agency, the individual's physical description including date of birth, color of eyes and hair, sex, height and weight, the time and date of arrest, the time and date of booking, the location of the arrest, the factual circumstances surrounding the arrest, the amount of bail set, the time and manner of release or the location where the individual is currently being held, and all charges the individual is being held upon, including any outstanding warrants from other jurisdictions and parole or probation holds.

(2) Subject to the restrictions imposed by Section 841.5 of the Penal Code, the time, substance, and location of all complaints or requests for assistance received by the agency and the time and nature of the response thereto, including, to the extent the information regarding crimes alleged or committed or any other incident investigated is recorded, the time, date, and location of occurrence, the time and date of the report, the name and age of the victim, the factual circumstances sur-

rounding the crime or incident, and a general description of any injuries, property, or weapons involved. The name of a victim of any crime defined by Section 220, 236.1, 261, 261.5, 262, 264, 264.1, 265, 266, 266a, 266b, 266c, 266e, 266f, 266j, 267, 269, 273a, 273d, 273.5, 285, 286, 288, 288a, 288.2, 288.3 (as added by Chapter 337 of the Statutes of 2006), 288.3 (as added by Section 6 of Proposition 83 of the November 7, 2006, statewide general election), 288.5, 288.7, 289, 422.6, 422.7, 422.75, 646.9, or 647.6 of the Penal Code may be withheld at the victim's request, or at the request of the victim's parent or guardian if the victim is a minor. When a person is the victim of more than one crime, information disclosing that the person is a victim of a crime defined in any of the sections of the Penal Code set forth in this subdivision may be deleted at the request of the victim, or the victim's parent or guardian if the victim is a minor, in making the report of the crime, or of any crime or incident accompanying the crime, available to the public in compliance with the requirements of this paragraph.

(3) Subject to the restrictions of Section 841.5 of the Penal Code and this subdivision, the current address of every individual arrested by the agency and the current address of the victim of a crime, where the requester declares under penalty of perjury that the request is made for a scholarly, journalistic, political, or governmental purpose, or that the request is made for investigation purposes by a licensed private investigator as described in Chapter 11.3 (commencing with Section 7512) of Division 3 of the Business and Professions Code. However, the address of the victim of any crime defined by Section 220, 236.1, 261, 261.5, 262, 264, 264.1, 265, 266, 266a, 266b, 266c, 266e, 266f, 266j, 267, 269, 273a, 273d, 273.5, 285, 286, 288, 288a, 288.2, 288.3 (as added by Chapter 337 of the Statutes of 2006), 288.3 (as added by Section 6 of Proposition 83 of the November 7, 2006, statewide general election), 288.5, 288.7, 289, 422.6, 422.7, 422.75, 646.9, or 647.6 of the Penal Code shall remain confidential. Address information obtained pursuant to this paragraph may not be used directly or indirectly, or furnished to another, to sell a product or service to any individual or group of individuals, and the requester shall execute a declaration to that effect under penalty of perjury. Nothing in this paragraph shall be construed to prohibit or limit a scholarly, journalistic, political, or government use of address information obtained pursuant to this paragraph.

(g) Test questions, scoring keys, and other examination data used to administer a licensing examination, examination for employment, or academic examination, except as provided for in Chapter 3 (commencing with Section 99150) of Part 65 of Division 14 of Title 3 of the Education Code.

(h) The contents of real estate appraisals or engineering or feasibility estimates and evaluations made for or by the state or local agency relative to the acquisition of property, or to prospective public supply and construction contracts, until all of the property has been acquired or all of the contract agreement obtained. However, the law of eminent domain shall not be affected by this provision.

(i) Information required from any taxpayer in connection with the collection of local taxes that is received in confidence and the disclosure of the information to other

persons would result in unfair competitive disadvantage to the person supplying the information.

(j) Library circulation records kept for the purpose of identifying the borrower of items available in libraries, and library and museum materials made or acquired and presented solely for reference or exhibition purposes. The exemption in this subdivision shall not apply to records of fines imposed on the borrowers.

(k) Records, the disclosure of which is exempted or prohibited pursuant to federal or state law, including, but not limited to, provisions of the Evidence Code relating to privilege.

(l) Correspondence of and to the Governor or employees of the Governor's office or in the custody of or maintained by the Governor's Legal Affairs Secretary. However, public records shall not be transferred to the custody of the Governor's Legal Affairs Secretary to evade the disclosure provisions of this chapter.

(m) In the custody of or maintained by the Legislative Counsel, except those records in the public database maintained by the Legislative Counsel that are described in Section 10248.

(n) Statements of personal worth or personal financial data required by a licensing agency and filed by an applicant with the licensing agency to establish his or her personal qualification for the license, certificate, or permit applied for.

(o) Financial data contained in applications for financing under Division 27 (commencing with Section 44500) of the Health and Safety Code, where an authorized officer of the California Pollution Control Financing Authority determines that disclosure of the financial data would be competitively injurious to the applicant and the data is required in order to obtain guarantees from the United States Small Business Administration. The California Pollution Control Financing Authority shall adopt rules for review of individual requests for confidentiality under this section and for making available to the public those portions of an application that are subject to disclosure under this chapter.

(p) Records of state agencies related to activities governed by Chapter 10.3 (commencing with Section 3512), Chapter 10.5 (commencing with Section 3525), and Chapter 12 (commencing with Section 3560) of Division 4, that reveal a state agency's deliberative processes, impressions, evaluations, opinions, recommendations, meeting minutes, research, work products, theories, or strategy, or that provide instruction, advice, or training to employees who do not have full collective bargaining and representation rights under these chapters. Nothing in this subdivision shall be construed to limit the disclosure duties of a state agency with respect to any other records relating to the activities governed by the employee relations acts referred to in this subdivision.

(q)(1) Records of state agencies related to activities governed by Article 2.6 (commencing with Section 14081), Article 2.8 (commencing with Section 14087.5), and Article 2.91 (commencing with Section 14089) of Chapter 7 of Part 3 of Division 9 of the Welfare and Institutions Code, that reveal the special negotiator's deliberative processes, discussions, communications, or any other portion of the negotiations with providers of health care services, impressions, opinions, recommendations, meeting minutes, research, work product, theo-

ries, or strategy, or that provide instruction, advice, or training to employees.

(2) Except for the portion of a contract containing the rates of payment, contracts for inpatient services entered into pursuant to these articles, on or after April 1, 1984, shall be open to inspection one year after they are fully executed. If a contract for inpatient services that is entered into prior to April 1, 1984, is amended on or after April 1, 1984, the amendment, except for any portion containing the rates of payment, shall be open to inspection one year after it is fully executed. If the California Medical Assistance Commission enters into contracts with health care providers for other than inpatient hospital services, those contracts shall be open to inspection one year after they are fully executed.

(3) Three years after a contract or amendment is open to inspection under this subdivision, the portion of the contract or amendment containing the rates of payment shall be open to inspection.

(4) Notwithstanding any other provision of law, the entire contract or amendment shall be open to inspection by the Joint Legislative Audit Committee and the Legislative Analyst's Office. The committee and that office shall maintain the confidentiality of the contracts and amendments until the time a contract or amendment is fully open to inspection by the public.

(r) Records of Native American graves, cemeteries, and sacred places and records of Native American places, features, and objects described in Sections 5097.9 and 5097.993 of the Public Resources Code maintained by, or in the possession of, the Native American Heritage Commission, another state agency, or a local agency.

(s) A final accreditation report of the Joint Commission on Accreditation of Hospitals that has been transmitted to the State Department of Health Care Services pursuant to subdivision (b) of Section 1282 of the Health and Safety Code.

(t) Records of a local hospital district, formed pursuant to Division 23 (commencing with Section 32000) of the Health and Safety Code, or the records of a municipal hospital, formed pursuant to Article 7 (commencing with Section 37600) or Article 8 (commencing with Section 37650) of Chapter 5 of Part 2 of Division 3 of Title 4 of this code, that relate to any contract with an insurer or nonprofit hospital service plan for inpatient or outpatient services for alternative rates pursuant to Section 10133 of the Insurance Code. However, the record shall be open to inspection within one year after the contract is fully executed.

(u)(1) Information contained in applications for licenses to carry firearms issued pursuant to Section 26150, 26155, 26170, or 26215 of the Penal Code by the sheriff of a county or the chief or other head of a municipal police department that indicates when or where the applicant is vulnerable to attack or that concerns the applicant's medical or psychological history or that of members of his or her family.

(2) The home address and telephone number of prosecutors, public defenders, peace officers, judges, court commissioners, and magistrates that are set forth in applications for licenses to carry firearms issued pursuant to Section 26150, 26155, 26170, or 26215 of the Penal Code by the sheriff of a county or the chief or other head of a municipal police department.

(3) The home address and telephone number of prosecutors, public defenders, peace officers, judges, court commissioners, and magistrates that are set forth in licenses to carry firearms issued pursuant to Section 26150, 26155, 26170, or 26215 of the Penal Code by the sheriff of a county or the chief or other head of a municipal police department.

(v)(1) Records of the Managed Risk Medical Insurance Board and the State Department of Health Care Services related to activities governed by Part 6.3 (commencing with Section 12695), Part 6.5 (commencing with Section 12700), Part 6.6 (commencing with Section 12739.5), and Part 6.7 (commencing with Section 12739.70) of Division 2 of the Insurance Code, and Chapter 2 (commencing with Section 15850) of Part 3.3 of Division 9 of the Welfare and Institutions Code, and that reveal any of the following:

(A) The deliberative processes, discussions, communications, or any other portion of the negotiations with entities contracting or seeking to contract with the board or the department, entities with which the board or the department is considering a contract, or entities with which the board is considering or enters into any other arrangement under which the board or the department provides, receives, or arranges services or reimbursement.

(B) The impressions, opinions, recommendations, meeting minutes, research, work product, theories, or strategy of the board or its staff or the department or its staff, or records that provide instructions, advice, or training to their employees.

(2)(A) Except for the portion of a contract that contains the rates of payment, contracts entered into pursuant to Part 6.3 (commencing with Section 12695), Part 6.5 (commencing with Section 12700), Part 6.6 (commencing with Section 12739.5), or Part 6.7 (commencing with Section 12739.70) of Division 2 of the Insurance Code, or Chapter 2.2 (commencing with Section 15850) of Part 3.3 of Division 9 of the Welfare and Institutions Code, on or after July 1, 1991, shall be open to inspection one year after their effective dates.

(B) If a contract that is entered into prior to July 1, 1991, is amended on or after July 1, 1991, the amendment, except for any portion containing the rates of payment, shall be open to inspection one year after the effective date of the amendment.

(3) Three years after a contract or amendment is open to inspection pursuant to this subdivision, the portion of the contract or amendment containing the rates of payment shall be open to inspection.

(4) Notwithstanding any other law, the entire contract or amendments to a contract shall be open to inspection by the Joint Legislative Audit Committee. The committee shall maintain the confidentiality of the contracts and amendments thereto, until the contracts or amendments to the contracts are open to inspection pursuant to paragraph (3).

(w)(1) Records of the Managed Risk Medical Insurance Board related to activities governed by Chapter 8 (commencing with Section 10700) of Part 2 of Division 2 of the Insurance Code, and that reveal the deliberative processes, discussions, communications, or any other portion of the negotiations with health plans, or the impressions, opinions, recommendations, meeting min-

utes, research, work product, theories, or strategy of the board or its staff, or records that provide instructions, advice, or training to employees.

(2) Except for the portion of a contract that contains the rates of payment, contracts for health coverage entered into pursuant to Chapter 8 (commencing with Section 10700) of Part 2 of Division 2 of the Insurance Code, on or after January 1, 1993, shall be open to inspection one year after they have been fully executed.

(3) Notwithstanding any other law, the entire contract or amendments to a contract shall be open to inspection by the Joint Legislative Audit Committee. The committee shall maintain the confidentiality of the contracts and amendments thereto, until the contracts or amendments to the contracts are open to inspection pursuant to paragraph (2).

(x) Financial data contained in applications for registration, or registration renewal, as a service contractor filed with the Director of Consumer Affairs pursuant to Chapter 20 (commencing with Section 9800) of Division 3 of the Business and Professions Code, for the purpose of establishing the service contractor's net worth, or financial data regarding the funded accounts held in escrow for service contracts held in force in this state by a service contractor.

(y)(1) Records of the Managed Risk Medical Insurance Board related to activities governed by Part 6.2 (commencing with Section 12693) or Part 6.4 (commencing with Section 12699.50) of Division 2 of the Insurance Code, and that reveal any of the following:

(A) The deliberative processes, discussions, communications, or any other portion of the negotiations with entities contracting or seeking to contract with the board, entities with which the board is considering a contract, or entities with which the board is considering or enters into any other arrangement under which the board provides, receives, or arranges services or reimbursement.

(B) The impressions, opinions, recommendations, meeting minutes, research, work product, theories, or strategy of the board or its staff, or records that provide instructions, advice, or training to employees.

(2)(A) Except for the portion of a contract that contains the rates of payment, contracts entered into pursuant to Part 6.2 (commencing with Section 12693) or Part 6.4 (commencing with Section 12699.50) of Division 2 of the Insurance Code, on or after January 1, 1998, shall be open to inspection one year after their effective dates.

(B) If a contract entered into pursuant to Part 6.2 (commencing with Section 12693) or Part 6.4 (commencing with Section 12699.50) of Division 2 of the Insurance Code is amended, the amendment shall be open to inspection one year after the effective date of the amendment.

(3) Three years after a contract or amendment is open to inspection pursuant to this subdivision, the portion of the contract or amendment containing the rates of payment shall be open to inspection.

(4) Notwithstanding any other law, the entire contract or amendments to a contract shall be open to inspection by the Joint Legislative Audit Committee. The committee shall maintain the confidentiality of the contracts and amendments thereto until the contract or amend-

ments to a contract are open to inspection pursuant to paragraph (2) or (3).

(5) The exemption from disclosure provided pursuant to this subdivision for the contracts, deliberative processes, discussions, communications, negotiations, impressions, opinions, recommendations, meeting minutes, research, work product, theories, or strategy of the board or its staff shall also apply to the contracts, deliberative processes, discussions, communications, negotiations, impressions, opinions, recommendations, meeting minutes, research, work product, theories, or strategy of applicants pursuant to Part 6.4 (commencing with Section 12699.50) of Division 2 of the Insurance Code.

(z) Records obtained pursuant to paragraph (2) of subdivision (f) of Section 2891.1 of the Public Utilities Code.

(aa) A document prepared by or for a state or local agency that assesses its vulnerability to terrorist attack or other criminal acts intended to disrupt the public agency's operations and that is for distribution or consideration in a closed session.

(ab) Critical infrastructure information, as defined in Section 131(3) of Title 6 of the United States Code, that is voluntarily submitted to the California Emergency Management Agency for use by that office, including the identity of the person who or entity that voluntarily submitted the information. As used in this subdivision, "voluntarily submitted" means submitted in the absence of the office exercising any legal authority to compel access to or submission of critical infrastructure information. This subdivision shall not affect the status of information in the possession of any other state or local governmental agency.

(ac) All information provided to the Secretary of State by a person for the purpose of registration in the Advance Health Care Directive Registry, except that those records shall be released at the request of a health care provider, a public guardian, or the registrant's legal representative.

(ad) The following records of the State Compensation Insurance Fund:

(1) Records related to claims pursuant to Chapter 1 (commencing with Section 3200) of Division 4 of the Labor Code, to the extent that confidential medical information or other individually identifiable information would be disclosed.

(2) Records related to the discussions, communications, or any other portion of the negotiations with entities contracting or seeking to contract with the fund, and any related deliberations.

(3) Records related to the impressions, opinions, recommendations, meeting minutes of meetings or sessions that are lawfully closed to the public, research, work product, theories, or strategy of the fund or its staff, on the development of rates, contracting strategy, underwriting, or competitive strategy pursuant to the powers granted to the fund in Chapter 4 (commencing with Section 11770) of Part 3 of Division 2 of the Insurance Code.

(4) Records obtained to provide workers' compensation insurance under Chapter 4 (commencing with Section 11770) of Part 3 of Division 2 of the Insurance Code, including, but not limited to, any medical claims information, policyholder information provided that nothing

in this paragraph shall be interpreted to prevent an insurance agent or broker from obtaining proprietary information or other information authorized by law to be obtained by the agent or broker, and information on rates, pricing, and claims handling received from brokers.

(5)(A) Records that are trade secrets pursuant to Section 6276.44, or Article 11 (commencing with Section 1060) of Chapter 4 of Division 8 of the Evidence Code, including without limitation, instructions, advice, or training provided by the State Compensation Insurance Fund to its board members, officers, and employees regarding the fund's special investigation unit, internal audit unit, and informational security, marketing, rating, pricing, underwriting, claims handling, audits, and collections.

(B) Notwithstanding subparagraph (A), the portions of records containing trade secrets shall be available for review by the Joint Legislative Audit Committee, the Bureau of State Audits, Division of Workers' Compensation, and the Department of Insurance to ensure compliance with applicable law.

(6)(A) Internal audits containing proprietary information and the following records that are related to an internal audit:

(i) Personal papers and correspondence of any person providing assistance to the fund when that person has requested in writing that his or her papers and correspondence be kept private and confidential. Those papers and correspondence shall become public records if the written request is withdrawn, or upon order of the fund.

(ii) Papers, correspondence, memoranda, or any substantive information pertaining to any audit not completed or an internal audit that contains proprietary information.

(B) Notwithstanding subparagraph (A), the portions of records containing proprietary information, or any information specified in subparagraph (A) shall be available for review by the Joint Legislative Audit Committee, the Bureau of State Audits, Division of Workers' Compensation, and the Department of Insurance to ensure compliance with applicable law.

(7)(A) Except as provided in subparagraph (C), contracts entered into pursuant to Chapter 4 (commencing with Section 11770) of Part 3 of Division 2 of the Insurance Code shall be open to inspection one year after the contract has been fully executed.

(B) If a contract entered into pursuant to Chapter 4 (commencing with Section 11770) of Part 3 of Division 2 of the Insurance Code is amended, the amendment shall be open to inspection one year after the amendment has been fully executed.

(C) Three years after a contract or amendment is open to inspection pursuant to this subdivision, the portion of

the contract or amendment containing the rates of payment shall be open to inspection.

(D) Notwithstanding any other law, the entire contract or amendments to a contract shall be open to inspection by the Joint Legislative Audit Committee. The committee shall maintain the confidentiality of the contracts and amendments thereto until the contract or amendments to a contract are open to inspection pursuant to this paragraph.

(E) This paragraph is not intended to apply to documents related to contracts with public entities that are not otherwise expressly confidential as to that public entity.

(F) For purposes of this paragraph, "fully executed" means the point in time when all of the necessary parties to the contract have signed the contract.

This section shall not prevent any agency from opening its records concerning the administration of the agency to public inspection, unless disclosure is otherwise prohibited by law.

This section shall not prevent any health facility from disclosing to a certified bargaining agent relevant financing information pursuant to Section 8 of the National Labor Relations Act (29 U.S.C. Sec. 158).

Added Stats 1981 ch 684 § 1.5, effective September 23, 1981, operative January 1, 1982. Amended Stats 1982 ch 83 § 1, effective March 1, 1982, ch 1492 § 2, ch 1594 § 2, effective September 30, 1982; Stats 1983 ch 200 § 1, effective July 12, 1983, ch 621 § 1, ch 955 § 1, ch 1315 § 1; Stats 1984 ch 1516 § 1, effective September 28, 1984; Stats 1985 ch 103 § 1; ch 1218 § 1; Stats 1986 ch 185 § 2; Stats 1987 ch 634 § 1, effective September 14, 1987, ch 635 § 1; Stats 1988 ch 870 § 1, ch 1371 § 2; Stats 1989 ch 191 § 1; Stats 1990 ch 1106 § 2 (SB 2106); Stats 1991 ch 278 § 1.2 (AB 99), effective July 30, 1991, ch 607 § 4 (SB 98); Stats 1992 ch 3 § 1 (AB 1681), effective February 10, 1992, ch 72 § 2 (AB 1525), effective May 28, 1992, ch 1128 § 2 (AB 1672), operative July 1, 1993; Stats 1993 ch 606 § 1 (AB 166), effective October 1, 1993 (ch 1265 prevails); Stats 1993 ch 610 § 1 (AB 6), effective October 1, 1993; Stats 1993 ch 611 § 1 (SB 60), effective October 1, 1993; Stats 1993 ch 1265 § 14 (SB 798); Stats 1994 ch 82 § 1 (AB 2547), ch 1263 § 1.5 (AB 1328); Stats 1995 ch 438 § 1 (AB 985), ch 777 § 2 (AB 958), ch 778 § 1.5 (SB 1059); Stats 1996 ch 1075 § 11 (SB 1444); Stats 1997 ch 623 § 1 (AB 1126); Stats 1998 ch 13 § 1 (AB 487), ch 110 § 1 (AB 1795) (ch 110 prevails), ch 485 § 83 (AB 2803); Stats 2000 ch 184 § 1 (AB 1349); Stats 2001 ch 159 § 105 (SB 662); Stats 2002 ch 175 § 1 (SB 1643); Stats 2003 ch 230 § 1 (AB 1762), effective August 11, 2003, ch 673 § 12 (SB 2); Stats 2004 ch 8 § 1 (AB 1209), effective January 22, 2004, ch 183 § 134 (AB 3082), ch 228 § 2 (SB 1103), effective August 16, 2004, ch 882 § 1 (AB 2445), ch 937 § 2.5 (AB 1933); Stats 2005 ch 22 § 71 (SB 1108), ch 476 § 1 (AB 1495), effective October 4, 2005, ch 670 § 1.5 (SB 922), effective October 7, 2005; Stats 2006 ch 538 § 232 (SB 1852); Stats 2007 ch 577 § 1 (AB 1750), effective October 13, 2007, ch 578 § 1.5 (SB 449); Stats 2008 ch 344 § 1 (SB 1145), effective September 26, 2008, ch 358 § 2 (AB 2810), ch 372 § 1.3 (AB 38), effective January 1, 2009; Stats 2010 ch 32 § 1 (AB 1887) (ch 32 prevails), effective June 29, 2010, ch 178 § 33 (SB 1115), effective January 1, 2011, operative January 1, 2012; Stats 2011 ch 285 § 7 (AB 1402), effective January 1, 2012. See this section as modified in Governor's Reorganization Plan No. 2 § 85 of 2012. Amended Stats 2012 ch 697 § 1 (AB 2221), effective January 1, 2013; Stats 2013 ch 23 § 2 (AB 82), effective June 27, 2013, ch 352 § 106 (AB 1317), effective September 26, 2013, operative July 1, 2013.

**TITLE 2**

**Government of the State of California**

**DIVISION 3**

**Executive Department**

**PART 1**

**State Departments and Agencies**

**CHAPTER 2**

**State Departments**

**ARTICLE 2**

**Investigations and Hearings**

Section

- 11180. Matters that may be investigated and prosecuted
- 11180.5. Assistance of state agencies in conducting investigation of unlawful activities; Request of prosecuting attorney or Attorney General; Disclosure of information
- 11181. Acts authorized in connection with investigations and actions
- 11182. Delegation of powers
- 11183. Divulging information; Offense; Disqualification
- 11184. Process; Subpoenas; Service; Compensation
- 11185. Attendance as witness; Natural persons; Witness that is not a natural person; Production of documents
- 11186. Compelling attendance as witness, giving of testimony, and production of papers
- 11187. Petition to compel giving of testimony or production of documents; Objections
- 11188. Order for person summoned to show cause; Order to appear; Contempt
- 11189. Depositions; Attendance of witnesses; Production of documents; Procedure
- 11190. Right of party to attendance of witnesses
- 11191. Fees and mileage of witnesses

**§ 11180. Matters that may be investigated and prosecuted**

The head of each department may make investigations and prosecute actions concerning:

- (a) All matters relating to the business activities and subjects under the jurisdiction of the department.
- (b) Violations of any law or rule or order of the department.
- (c) Such other matters as may be provided by law.

Added Stats 1945 ch 111 § 3.

**§ 11180.5. Assistance of state agencies in conducting investigation of unlawful activities; Request of prosecuting attorney or Attorney General; Disclosure of information**

At the request of a prosecuting attorney or the Attorney General, any agency, bureau, or department of this state, any other state, or the United States may assist in conducting an investigation of any unlawful activity that involves matters within or reasonably related to the jurisdiction of the agency, bureau, or department. This investigation may be made in cooperation with the prosecuting attorney or the Attorney General. The prosecuting attorney or the Attorney General may disclose

documents or information acquired pursuant to the investigation to another agency, bureau, or department if the agency, bureau, or department agrees to maintain the confidentiality of the documents or information received to the extent required by this article.

Added Stats 1977 ch 891 § 1. Amended Stats 2003 ch 876 § 5 (SB 434).

**§ 11181. Acts authorized in connection with investigations and actions**

In connection with any investigation or action authorized by this article, the department head may do any of the following:

- (a) Inspect and copy books, records, and other items described in subdivision (e).
- (b) Hear complaints.
- (c) Administer oaths.
- (d) Certify to all official acts.
- (e) Issue subpoenas for the attendance of witnesses and the production of papers, books, accounts, documents, any writing as defined by Section 250 of the Evidence Code, tangible things, and testimony pertinent or material to any inquiry, investigation, hearing, proceeding, or action conducted in any part of the state.
- (f) Promulgate interrogatories pertinent or material to any inquiry, investigation, hearing, proceeding, or action.

(g) Divulge information or evidence related to the investigation of unlawful activity discovered from interrogatory answers, papers, books, accounts, documents, and any other item described in subdivision (e), or testimony, to the Attorney General or to any prosecuting attorney of this state, any other state, or the United States who has a responsibility for investigating the unlawful activity investigated or discovered, or to any governmental agency responsible for enforcing laws related to the unlawful activity investigated or discovered, if the Attorney General, prosecuting attorney, or agency to which the information or evidence is divulged agrees to maintain the confidentiality of the information received to the extent required by this article.

(h) Present information or evidence obtained or developed from the investigation of unlawful activity to a court or at an administrative hearing in connection with any action or proceeding.

Added Stats 1945 ch 111 § 3. Amended Stats 1981 ch 778 § 1; Stats 1987 ch 1453 § 8; Stats 2001 ch 74 § 2 (AB 260); Stats 2003 ch 876 § 6 (SB 434).

**§ 11182. Delegation of powers**

The head of a department may delegate the powers conferred upon him by this article to any officer of the department he authorizes to conduct the investigation or hearing.

Added Stats 1945 ch 111 § 3.

**§ 11183. Divulging information; Offense; Disqualification**

Except in a report to the head of the department or when called upon to testify in any court or proceeding at

law or as provided in Section 11180.5 or subdivisions (g) and (h) of Section 11181, an officer shall not divulge any information or evidence acquired by the officer from the interrogatory answers or subpoenaed private books, documents, papers, or other items described in subdivision (e) of Section 11181 of any person while acting or claiming to act under any authorization pursuant to this article, in respect to the confidential or private transactions, property or business of any person. An officer who divulges information or evidence in violation of this section is guilty of a misdemeanor and disqualified from acting in any official capacity in the department.

Added Stats 1945 ch 111 § 3. Amended Stats 1981 ch 778 § 2; Stats 2003 ch 876 § 7 (SB 434).

**§ 11184. Process; Subpoenas; Service; Compensation**

(a) In any hearing in any part of the state or in any investigation conducted under this article, the head of the department shall issue process and subpoenas in a manner consistent with the California Constitution and the United States Constitution, and the process and subpoenas shall be served in the same manner as provided for the service of a summons as described in Chapter 4 (commencing with Section 413.10) of Title 5 of Part 2 of the Code of Civil Procedure. Service of process and subpoenas may be effectuated by any person designated for that purpose by the head of the department. The person serving any process or a subpoena may receive compensation as is allowed by the head of the department not to exceed the fees prescribed by law for similar service. This compensation shall be paid in the manner provided in this article for the payment of the fees of witnesses.

(b) If the subpoena requires oral testimony from a witness who is not a natural person, the subpoena shall describe, with reasonable particularity, the matters on which examination is requested. In that event, the subpoenaed witness shall designate and produce at the hearing those natural persons who are most qualified to testify on behalf of the subpoenaed witness about those matters to the extent of any information known or reasonably available to the subpoenaed witness. The subpoena shall notify the witness named in the subpoena of its duty to designate and produce natural persons to testify as described in this subdivision.

Added Stats 1945 ch 111 § 3. Amended Stats 2003 ch 876 § 8 (SB 434).

**§ 11185. Attendance as witness; Natural persons; Witness that is not a natural person; Production of documents**

(a) If the witness named in the subpoena is a natural person, the person is not obliged to attend as a witness in any matter under this article at a place out of the county in which he or she resides, unless the distance is less than 75 miles from his or her place of residence.

(b) If the witness named in the subpoena is not a natural person and has an office within this state, the subpoena may provide that the testimony of the persons designated to appear on behalf of the witness, as described in subdivision (b) of Section 11184, shall be given in the county in which the witness named in the subpoena has its principal executive or business office in this state or within 150 miles of that location.

(c) If the witness conducts business in this state but does not reside or have an office within this state, the subpoena may provide that oral testimony shall be given at a location that is within 75 miles of the residence or executive or business office of the witness.

(d) If the witness does not reside, have an office, or conduct business in this state, the testimony shall be given and documents and other items produced at a location set by a court.

(e) The department head may require any person who resides or conducts business in this state to produce the documents and other items described in subdivision (e) of Section 11181 at a location in the county in which the department head or the Attorney General maintains an office.

(f) Nothing in this section prevents the department head and subpoenaed person from agreeing that testimony may be given or production made at any location.

Added Stats 1945 ch 111 § 3. Amended Stats 2003 ch 876 § 9 (SB 434).

**§ 11186. Compelling attendance as witness, giving of testimony, and production of papers**

The superior court in the county in which any hearing is held or any investigation is conducted under the direction of the head of a department or the county in which testimony is designated to be given or documents or other items are designated to be produced, has jurisdiction to compel the attendance of witnesses, the giving of testimony, the answering without objection of interrogatories, and the production, inspection, and copying of papers, books, accounts, documents, and other items described in subdivision (e) of Section 11181 as required by any subpoena issued by the department head.

Added Stats 1945 ch 111 § 3. Amended Stats 2003 ch 876 § 10 (SB 434).

**§ 11187. Petition to compel giving of testimony or production of documents; Objections**

(a) Except as provided in subdivision (c), if any witness refuses to answer any interrogatory or to attend or testify or produce or permit the inspection or copying of any papers or other items described in subdivision (e) of Section 11181 required by subpoena, the head of the department may petition the superior court in the county in which the hearing or investigation is pending or the county in which testimony is designated in the subpoena to be given or documents or other items are designated in the subpoena to be produced, for an order compelling the person to answer the interrogatories or to attend and testify or produce and permit the inspection and copying of the papers or other items required by the subpoena before the officer named in the subpoena.

(b) The petition shall set forth all of the following:

(1) That due notice of the time and place for answering the interrogatories or testifying or the attendance of the person or the production of the papers or other items described in subdivision (e) of Section 11181 was given.

(2) That the person was subpoenaed or required to answer interrogatories in the manner prescribed in this article.

(3) That the person failed and refused to answer the interrogatories or to attend or testify or produce or permit the inspection or copying of the papers or other items required by subpoena before the officer in the

cause or proceeding named in the subpoena, or has refused to answer questions propounded to him or her in the course of the investigation or hearing.

(c) If the witness named in the subpoena does not reside or conduct business in this state, the department head may seek to compel the witness' testimony and production, inspection, and copying of documents or other items described in subdivision (e) of Section 11181 in the manner provided for the enforcement of a deposition notice to a nonparty as described in Section 2026.010 or 2027.010 of the Code of Civil Procedure or in any other manner authorized by any law.

(d) If any witness objects and based on that objection refuses to answer any interrogatory or to attend or testify or produce or permit the inspection or copying of any papers or other items described in subdivision (e) of Section 11181 as required by a subpoena, the witness shall state the objection and the validity of the objection shall be determined exclusively in a proceeding brought by the head of the department to compel compliance as provided in this section.

Added Stats 1945 ch 111 § 3. Amended Stats 2001 ch 74 § 3 (AB 260); 2003 ch 876 § 11 (SB 434); Stats 2004 ch 182 § 40 (AB 3081), operative July 1, 2005.

**§ 11188. Order for person summoned to show cause; Order to appear; Contempt**

Upon the filing of the petition the court shall enter an order directing the person to appear before the court at a specified time and place and then and there show cause why he or she has not attended, testified, answered interrogatories, or produced or permitted the inspection or copying of the papers or other items described in subdivision (e) of Section 11181 as required. A copy of the order shall be served upon him or her in the manner provided for the service of a summons described in Chapter 4 (commencing with Section 413.10) of Title 5 of Part 2 of the Code of Civil Procedure. If it appears to the court that the subpoena was regularly issued, or the interrogatories were regularly promulgated, by the head of the department, the court shall enter an order that the person appear before the officer named in the subpoena at the time and place fixed in the order and testify or produce and permit the inspection and copying of the required papers or other items described in subdivision (e) of Section 11181 as required or answer the interrogatories without objection. At the request of the department head, the court may issue any additional order to aid the implementation of the order enforcing compliance with the subpoena, including the issuance of a commission or letters rogatory in the manner provided for the enforcement of a deposition notice to a nonparty as described in Section 2026 or 2027 of the Code of Civil Procedure. Upon failure to obey the order, the person shall be dealt with as for contempt of court.

Added Stats 1945 ch 111 § 3. Amended Stats 2003 ch 876 § 12 (SB 434).

**§ 11189. Depositions; Attendance of witnesses; Production of documents; Procedure**

In any matter pending before a department head, the department head may cause the deposition of persons residing within or without the state to be taken by causing a petition to be filed in the Superior Court in the County of Sacramento reciting the nature of the matter

pending, the name and residence of the person whose testimony is desired, and asking that an order be made requiring the person to appear and testify before an officer named in the petition for that purpose. Upon the filing of the petition the court may make an order requiring the person to appear and testify in the manner prescribed by law for like depositions in civil actions in the superior courts of this state under Title 4 (commencing with Section 2016.010) of Part 4 of the Code of Civil Procedure. In the same manner the superior courts may compel the attendance of persons as witnesses, and the production of papers, books, accounts, and documents, under Chapter 2 (commencing with Section 1985) of Title 3 of Part 4 of the Code of Civil Procedure, and may punish for contempt.

Added Stats 1945 ch 111 § 3. Amended Stats 1998 ch 931 § 181 (SB 2139), effective September 28, 1998; Stats 2004 ch 182 § 41 (AB 3081), operative July 1, 2005.

**§ 11190. Right of party to attendance of witnesses**

Any party to any departmental hearing has the right to the attendance of witnesses in his behalf at the hearing or upon deposition upon making request therefor to the head of the department, designating the persons sought to be subpoenaed, and depositing with the officer before whom the hearing is to be had the necessary fees and mileage.

Added Stats 1945 ch 111 § 3.

**§ 11191. Fees and mileage of witnesses**

Each witness, other than an officer or employee of the State or of a political subdivision of the State, who appears by order of the head of a department shall receive for his attendance the same fees and all witnesses shall receive the same mileage allowed by law to a witness in civil cases. The amounts shall be paid by the party at whose request the witness is subpoenaed. The mileage, and fees, if any, of a witness subpoenaed by the head of a department, but not at the request of a party, shall be paid from the funds appropriated for the use of the department in the same manner as other expenses of the department are paid.

Added Stats 1945 ch 111 § 3.

**CHAPTER 3.5**

**Administrative Regulations and Rulemaking**

**ARTICLE 1**

**General**

Section

11340. Legislative findings and declarations

11340.1. Declarations and intent regarding establishment of Office of Administrative Law

11340.2. Office of Administrative Law; Director and deputy director

11340.3. Employment and compensation of assistants and other employees

11340.4. Recommendations on administrative rulemaking

11340.5. Adoption of guidelines, bulletins and manuals as regulations

11340.6. Petition requesting adoption, amendment, or repeal of regulation; Contents



## Section

- 11340.7. Procedure upon petition requesting adoption, amendment or repeal of regulation
- 11340.85. Electronic communications
- 11340.9. Inapplicable provisions
- 11341. Identification numbers
- 11342.1. Authority not conferred on state agencies
- 11342.2. Consistency with statute; Effectuation of purpose of statute
- 11342.4. Regulations

**§ 11340. Legislative findings and declarations**

The Legislature finds and declares as follows:

(a) There has been an unprecedented growth in the number of administrative regulations in recent years.

(b) The language of many regulations is frequently unclear and unnecessarily complex, even when the complicated and technical nature of the subject matter is taken into account. The language is often confusing to the persons who must comply with the regulations.

(c) Substantial time and public funds have been spent in adopting regulations, the necessity for which has not been established.

(d) The imposition of prescriptive standards upon private persons and entities through regulations where the establishment of performance standards could reasonably be expected to produce the same result has placed an unnecessary burden on California citizens and discouraged innovation, research, and development of improved means of achieving desirable social goals.

(e) There exists no central office in state government with the power and duty to review regulations to ensure that they are written in a comprehensible manner, are authorized by statute, and are consistent with other law.

(f) Correcting the problems that have been caused by the unprecedented growth of regulations in California requires the direct involvement of the Legislature as well as that of the executive branch of state government.

(g) The complexity and lack of clarity in many regulations put small businesses, which do not have the resources to hire experts to assist them, at a distinct disadvantage.

Added Stats 1979 ch 567 § 1, operative July 1, 1980. Amended Stats 1981 ch 865 § 2; Stats 1983 ch 874 § 1; Stats 1993 ch 870 § 1 (SB 726).

**§ 11340.1. Declarations and intent regarding establishment of Office of Administrative Law**

(a) The Legislature therefore declares that it is in the public interest to establish an Office of Administrative Law which shall be charged with the orderly review of adopted regulations. It is the intent of the Legislature that the purpose of such review shall be to reduce the number of administrative regulations and to improve the quality of those regulations which are adopted. It is the intent of the Legislature that agencies shall actively seek to reduce the unnecessary regulatory burden on private individuals and entities by substituting performance standards for prescriptive standards wherever performance standards can be reasonably expected to be as effective and less burdensome, and that this substitution shall be considered during the course of the agency rulemaking process. It is the intent of the Legislature that neither the Office of Administrative Law nor the court should substitute its judgment for that of the rulemaking agency as expressed in the substantive content of adopted regulations. It is the intent of the

Legislature that while the Office of Administrative Law will be part of the executive branch of state government, that the office work closely with, and upon request report directly to, the Legislature in order to accomplish regulatory reform in California.

(b) It is the intent of the Legislature that the California Code of Regulations made available on the Internet by the office pursuant to Section 11344 include complete authority and reference citations and history notes.

Added Stats 1979 ch 567 § 1, operative July 1, 1980. Amended Stats 1981 ch 865 § 3; Stats 1983 ch 874 § 2; Stats 1996 ch 501 § 1 (SB 1910).

**§ 11340.2. Office of Administrative Law; Director and deputy director**

(a) The Office of Administrative Law is hereby established in state government in the Government Operations Agency. The office shall be under the direction and control of an executive officer who shall be known as the director. There shall also be a deputy director. The director's term and the deputy director's term of office shall be coterminous with that of the appointing power, except that they shall be subject to reappointment.

(b) The director and deputy director shall have the same qualifications as a hearing officer and shall be appointed by the Governor subject to the confirmation of the Senate.

Added Stats 1979 ch 567 § 1, operative July 1, 1980. Amended Stats 1980 ch 992 § 1.5. See this section as modified in Governor's Reorganization Plan No. 2 § 175 of 2012. Amended Stats 2013 ch 352 § 235 (AB 1317), effective September 26, 2013, operative July 1, 2013.

**§ 11340.3. Employment and compensation of assistants and other employees**

The director may employ and fix the compensation, in accordance with law, of such professional assistants and clerical and other employees as is deemed necessary for the effective conduct of the work of the office.

Added Stats 1979 ch 567 § 1, operative July 1, 1980.

**§ 11340.4. Recommendations on administrative rulemaking**

(a) The office is authorized and directed to do the following:

(1) Study the subject of administrative rulemaking in all its aspects.

(2) In the interest of fairness, uniformity, and the expedition of business, submit its suggestions to the various agencies.

(3) Report its recommendations to the Governor and Legislature at the commencement of each general session.

(b) All agencies of the state shall give the office ready access to their records and full information and reasonable assistance in any matter of research requiring recourse to them or to data within their knowledge or control. Nothing in this subdivision authorizes an agency to provide access to records required by statute to be kept confidential.

Added Stats 1995 ch 938 § 14 (SB 523), operative July 1, 1997.

**§ 11340.5. Adoption of guidelines, bulletins and manuals as regulations**

(a) No state agency shall issue, utilize, enforce, or attempt to enforce any guideline, criterion, bulletin,

manual, instruction, order, standard of general application, or other rule, which is a regulation as defined in Section 11342.600, unless the guideline, criterion, bulletin, manual, instruction, order, standard of general application, or other rule has been adopted as a regulation and filed with the Secretary of State pursuant to this chapter.

(b) If the office is notified of, or on its own, learns of the issuance, enforcement of, or use of, an agency guideline, criterion, bulletin, manual, instruction, order, standard of general application, or other rule that has not been adopted as a regulation and filed with the Secretary of State pursuant to this chapter, the office may issue a determination as to whether the guideline, criterion, bulletin, manual, instruction, order, standard of general application, or other rule, is a regulation as defined in Section 11342.600.

(c) The office shall do all of the following:

(1) File its determination upon issuance with the Secretary of State.

(2) Make its determination known to the agency, the Governor, and the Legislature.

(3) Publish its determination in the California Regulatory Notice Register within 15 days of the date of issuance.

(4) Make its determination available to the public and the courts.

(d) Any interested person may obtain judicial review of a given determination by filing a written petition requesting that the determination of the office be modified or set aside. A petition shall be filed with the court within 30 days of the date the determination is published.

(e) A determination issued by the office pursuant to this section shall not be considered by a court, or by an administrative agency in an adjudicatory proceeding if all of the following occurs:

(1) The court or administrative agency proceeding involves the party that sought the determination from the office.

(2) The proceeding began prior to the party's request for the office's determination.

(3) At issue in the proceeding is the question of whether the guideline, criterion, bulletin, manual, instruction, order, standard of general application, or other rule that is the legal basis for the adjudicatory action is a regulation as defined in Section 11342.600.

Added Stats 1994 ch 1039 § 4 (AB 2531). Amended Stats 1995 ch 938 § 15 (SB 523), operative January 1, 1996; Stats 2000 ch 1060 § 3 (AB 1822).

#### **§ 11340.6. Petition requesting adoption, amendment, or repeal of regulation; Contents**

Except where the right to petition for adoption of a regulation is restricted by statute to a designated group or where the form of procedure for such a petition is otherwise prescribed by statute, any interested person may petition a state agency requesting the adoption, amendment, or repeal of a regulation as provided in Article 5 (commencing with Section 11346). This petition shall state the following clearly and concisely:

(a) The substance or nature of the regulation, amendment, or repeal requested.

(b) The reason for the request.

(c) Reference to the authority of the state agency to take the action requested.

Added Stats 1994 ch 1039 § 5 (AB 2531).

#### **§ 11340.7. Procedure upon petition requesting adoption, amendment or repeal of regulation**

(a) Upon receipt of a petition requesting the adoption, amendment, or repeal of a regulation pursuant to Article 5 (commencing with Section 11346), a state agency shall notify the petitioner in writing of the receipt and shall within 30 days deny the petition indicating why the agency has reached its decision on the merits of the petition in writing or schedule the matter for public hearing in accordance with the notice and hearing requirements of that article.

(b) A state agency may grant or deny the petition in part, and may grant any other relief or take any other action as it may determine to be warranted by the petition and shall notify the petitioner in writing of this action.

(c) Any interested person may request a reconsideration of any part or all of a decision of any agency on any petition submitted. The request shall be submitted in accordance with Section 11340.6 and include the reason or reasons why an agency should reconsider its previous decision no later than 60 days after the date of the decision involved. The agency's reconsideration of any matter relating to a petition shall be subject to subdivision (a).

(d) Any decision of a state agency denying in whole or in part or granting in whole or in part a petition requesting the adoption, amendment, or repeal of a regulation pursuant to Article 5 (commencing with Section 11346) shall be in writing and shall be transmitted to the Office of Administrative Law for publication in the California Regulatory Notice Register at the earliest practicable date. The decision shall identify the agency, the party submitting the petition, the provisions of the California Code of Regulations requested to be affected, reference to authority to take the action requested, the reasons supporting the agency determination, an agency contact person, and the right of interested persons to obtain a copy of the petition from the agency.

Added Stats 1994 ch 1994 ch 1039 § 6 (AB 2531).

#### **§ 11340.85. Electronic communications**

(a) As used in this section, "electronic communication" includes electronic transmission of written or graphical material by electronic mail, facsimile, or other means, but does not include voice communication.

(b) Notwithstanding any other provision of this chapter that refers to mailing or sending, or to oral or written communication:

(1) An agency may permit and encourage use of electronic communication, but may not require use of electronic communication.

(2) An agency may publish or distribute a document required by this chapter or by a regulation implementing this chapter by means of electronic communication, but shall not make that the exclusive means by which the document is published or distributed.

(3) A notice required or authorized by this chapter or by a regulation implementing this chapter may be deliv-

ered to a person by means of electronic communication if the person has expressly indicated a willingness to receive the notice by means of electronic communication.

(4) A comment regarding a regulation may be delivered to an agency by means of electronic communication.

(5) A petition regarding a regulation may be delivered to an agency by means of electronic communication if the agency has expressly indicated a willingness to receive a petition by means of electronic communication.

(c) An agency that maintains an Internet Web site or other similar forum for the electronic publication or distribution of written material shall publish on that Web site or other forum information regarding a proposed regulation or regulatory repeal or amendment, that includes, but is not limited to, the following:

(1) Any public notice required by this chapter or by a regulation implementing this chapter.

(2) The initial statement of reasons prepared pursuant to subdivision (b) of Section 11346.2.

(3) The final statement of reasons prepared pursuant to subdivision (a) of Section 11346.9.

(4) Notice of a decision not to proceed prepared pursuant to Section 11347.

(5) The text of a proposed action or instructions on how to obtain a copy of the text.

(6) A statement of any decision made by the office regarding a proposed action.

(7) The date a rulemaking action is filed with the Secretary of State.

(8) The effective date of a rulemaking action.

(9) A statement to the effect that a business or person submitting a comment regarding a proposed action has the right to request a copy of the final statement of reasons.

(10) The text of a proposed emergency adoption, amendment, or repeal of a regulation pursuant to Section 11346.1 and the date it was submitted to the office for review and filing.

(d) A document that is required to be posted pursuant to subdivision (c) shall be posted within a reasonable time after issuance of the document, and shall remain posted until at least 15 days after (1) the rulemaking action is filed with the Secretary of State, or (2) notice of a decision not to proceed is published pursuant to Section 11347. Publication under subdivision (c) supplements any other required form of publication or distribution. Failure to comply with this section is not grounds for disapproval of a proposed regulation. Subdivision (c) does not require an agency to establish or maintain a Web site or other forum for the electronic publication or distribution of written material.

(e) Nothing in this section precludes the office from requiring that the material submitted to the office for publication in the California Code of Regulations or the California Regulatory Notice Register be submitted in electronic form.

(f) This section is intended to make the regulatory process more user-friendly and to improve communication between interested parties and the regulatory agencies.

Added Stats 2000 ch 1060 § 4 (AB 1822). Amended Stats 2001 ch 59 § 2 (SB 561); Stats 2002 ch 389 § 2 (AB 1857); Stats 2006 ch 713 § 1 (AB 1302), effective January 1, 2007.

#### § 11340.9. Inapplicable provisions

This chapter does not apply to any of the following:

(a) An agency in the judicial or legislative branch of the state government.

(b) A legal ruling of counsel issued by the Franchise Tax Board or State Board of Equalization.

(c) A form prescribed by a state agency or any instructions relating to the use of the form, but this provision is not a limitation on any requirement that a regulation be adopted pursuant to this chapter when one is needed to implement the law under which the form is issued.

(d) A regulation that relates only to the internal management of the state agency.

(e) A regulation that establishes criteria or guidelines to be used by the staff of an agency in performing an audit, investigation, examination, or inspection, settling a commercial dispute, negotiating a commercial arrangement, or in the defense, prosecution, or settlement of a case, if disclosure of the criteria or guidelines would do any of the following:

(1) Enable a law violator to avoid detection.

(2) Facilitate disregard of requirements imposed by law.

(3) Give clearly improper advantage to a person who is in an adverse position to the state.

(f) A regulation that embodies the only legally tenable interpretation of a provision of law.

(g) A regulation that establishes or fixes rates, prices, or tariffs.

(h) A regulation that relates to the use of public works, including streets and highways, when the effect of the regulation is indicated to the public by means of signs or signals or when the regulation determines uniform standards and specifications for official traffic control devices pursuant to Section 21400 of the Vehicle Code.

(i) A regulation that is directed to a specifically named person or to a group of persons and does not apply generally throughout the state.

Added Stats 2000 ch 1060 § 5 (AB 1822).

#### § 11341. Identification numbers

(a) The office shall establish a system to give a unique identification number to each regulatory action.

(b) The office and the state agency taking the regulatory action shall use the identification number given by the office pursuant to subdivision (a) to refer to the regulatory action for which a notice has already been published in the California Regulatory Notice Register.

(c) The identification number shall be sufficient information for a member of the public to identify and track a regulatory action both with the office and the state agency taking the regulatory action. No other information pertaining to the regulatory action shall be required of a member of the public if the identification number of the regulatory action has been provided.

Added Stats 2000 ch 1059 § 5 (AB 505).

#### § 11342.1. Authority not conferred on state agencies

Except as provided in Section 11342.4, nothing in this chapter confers authority upon or augments the authority of any state agency to adopt, administer, or enforce

any regulation. Each regulation adopted, to be effective, shall be within the scope of authority conferred and in accordance with standards prescribed by other provisions of law.

Added Stats 1979 ch 567 § 1, operative July 1, 1980. Amended Stats 1987 ch 1375 § 2.

**§ 11342.2. Consistency with statute; Effectuation of purpose of statute**

Whenever by the express or implied terms of any statute a state agency has authority to adopt regulations to implement, interpret, make specific or otherwise carry out the provisions of the statute, no regulation adopted is valid or effective unless consistent and not in conflict with the statute and reasonably necessary to effectuate the purpose of the statute.

Added Stats 1979 ch 567 § 1, operative July 1, 1980.

**§ 11342.4. Regulations**

The office shall adopt, amend, or repeal regulations for the purpose of carrying out the provisions of this chapter.

Added Stats 1981 ch 865 § 19, as Gov C § 11344.6. Amended Stats 1982 ch 1573 § 1. Renumbered by Stats 1983 ch 797 § 12.

## ARTICLE 2

### Definitions

Section

- 11342.510. Governing definitions
- 11342.520. "Agency"
- 11342.530. "Building standard"
- 11342.535. "Cost impact"
- 11342.540. "Director"
- 11342.545. "Emergency"
- 11342.548. "Major regulation"
- 11342.550. "Office"
- 11342.560. "Order of repeal"
- 11342.570. "Performance standard"
- 11342.580. "Plain English"
- 11342.590. "Prescriptive standard"
- 11342.595. "Proposed action"
- 11342.600. "Regulation"
- 11342.610. "Small Business"

**§ 11342.510. Governing definitions**

Unless the provision or context otherwise requires, the definitions in this article govern the construction of this chapter.

Added Stats 2000 ch 1060 § 8 (AB 1822).

**§ 11342.520. "Agency"**

"Agency" means state agency.

Added Stats 2000 ch 1060 § 8 (AB 1822).

**§ 11342.530. "Building standard"**

"Building standard" has the same meaning provided in Section 18909 of the Health and Safety Code.

Added Stats 2000 ch 1060 § 8 (AB 1822).

**§ 11342.535. "Cost impact"**

"Cost impact" means the amount of reasonable range of direct costs, or a description of the type and extent of direct costs, that a representative private person or business necessarily incurs in reasonable compliance with the proposed action.

Added Stats 2000 ch 1059 § 6.5 (AB 505).

**§ 11342.540. "Director"**

"Director" means the director of the office.

Added Stats 2000 ch 1060 § 8 (AB 1822).

**§ 11342.545. "Emergency"**

"Emergency" means a situation that calls for immediate action to avoid serious harm to the public peace, health, safety, or general welfare.

Added Stats 2006 ch 713 § 2 (AB 1302), effective January 1, 2007.

**§ 11342.548. "Major regulation"**

"Major regulation" means any proposed adoption, amendment, or repeal of a regulation subject to review by the Office of Administrative Law pursuant to Article 6 (commencing with Section 11349) that will have an economic impact on California business enterprises and individuals in an amount exceeding fifty million dollars (\$50,000,000), as estimated by the agency.

Added Stats 2011 ch 496 § 1 (SB 617), effective January 1, 2012.

**§ 11342.550. "Office"**

"Office" means the Office of Administrative Law.

Added Stats 2000 ch 1060 § 8 (AB 1822).

**§ 11342.560. "Order of repeal"**

"Order of repeal" means any resolution, order, or other official act of a state agency that expressly repeals a regulation in whole or in part.

Added Stats 2000 ch 1060 § 8 (AB 1822).

**§ 11342.570. "Performance standard"**

"Performance standard" means a regulation that describes an objective with the criteria stated for achieving the objective.

Added Stats 2000 ch 1060 § 8 (AB 1822).

**§ 11342.580. "Plain English"**

"Plain English" means language that satisfies the standard of clarity provided in Section 11349.

Added Stats 2000 ch 1060 § 8 (AB 1822).

**§ 11342.590. "Prescriptive standard"**

"Prescriptive standard" means a regulation that specifies the sole means of compliance with a performance standard by specific actions, measurements, or other quantifiable means.

Added Stats 2000 ch 1060 § 8 (AB 1822).

**§ 11342.595. "Proposed action"**

"Proposed action" means the regulatory action, notice of which is submitted to the office for publication in the California Regulatory Notice Register.

Added Stats 2000 ch 1059 § 6.7 (AB 505). Amended Stats 2001 ch 59 § 3 (SB 561).

**§ 11342.600. "Regulation"**

"Regulation" means every rule, regulation, order, or standard of general application or the amendment, supplement, or revision of any rule, regulation, order, or standard adopted by any state agency to implement, interpret, or make specific the law enforced or administered by it, or to govern its procedure.

Added Stats 2000 ch 1060 § 8 (AB 1822).

**§ 11342.610. “Small Business”**

(a) “Small business” means a business activity in agriculture, general construction, special trade construction, retail trade, wholesale trade, services, transportation and warehousing, manufacturing, generation and transmission of electric power, or a health care facility, unless excluded in subdivision (b), that is both of the following:

- (1) Independently owned and operated.
- (2) Not dominant in its field of operation.

(b) “Small business” does not include the following professional and business activities:

(1) A financial institution including a bank, a trust, a savings and loan association, a thrift institution, a consumer finance company, a commercial finance company, an industrial finance company, a credit union, a mortgage and investment banker, a securities broker-dealer, or an investment adviser.

(2) An insurance company, either stock or mutual.

(3) A mineral, oil, or gas broker.

(4) A subdivider or developer.

(5) A landscape architect, an architect, or a building designer.

(6) An entity organized as a nonprofit institution.

(7) An entertainment activity or production, including a motion picture, a stage performance, a television or radio station, or a production company.

(8) A utility, a water company, or a power transmission company generating and transmitting more than 4.5 million kilowatt hours annually.

(9) A petroleum producer, a natural gas producer, a refiner, or a pipeline.

(10) A manufacturing enterprise exceeding 250 employees.

(11) A health care facility exceeding 150 beds or one million five hundred thousand dollars (\$1,500,000) in annual gross receipts.

(c) “Small business” does not include the following business activities:

(1) Agriculture, where the annual gross receipts exceed one million dollars (\$1,000,000).

(2) General construction, where the annual gross receipts exceed nine million five hundred thousand dollars (\$9,500,000).

(3) Special trade construction, where the annual gross receipts exceed five million dollars (\$5,000,000).

(4) Retail trade, where the annual gross receipts exceed two million dollars (\$2,000,000).

(5) Wholesale trade, where the annual gross receipts exceed nine million five hundred thousand dollars (\$9,500,000).

(6) Services, where the annual gross receipts exceed two million dollars (\$2,000,000).

(7) Transportation and warehousing, where the annual gross receipts exceed one million five hundred thousand dollars (\$1,500,000).

Added Stats 2000 ch 1060 § 8 (AB 1822).

**ARTICLE 3****Filing and Publication**

Section  
11343. Procedure

Section

11343.1. Style of regulations; Endorsement

11343.2. Endorsement of time and date of filing and maintenance of file for public inspection

11343.3. Vehicle weight impacts and ability of vehicle manufacturers or operators to comply with laws limiting weight of vehicles to be taken into account when promulgating administrative regulations

11343.4. Effective date of regulation or order of repeal; Applicability

11343.5. Filing copies of Code of Regulations or Regulatory Code Supplement

11343.6. Rebuttable presumptions raised by filing of certified copy

11343.8. Filing and publication of regulation or order of repeal not required to be filed

**§ 11343. Procedure**

Every state agency shall:

(a) Transmit to the office for filing with the Secretary of State a certified copy of every regulation adopted or amended by it except one that is a building standard.

(b) Transmit to the office for filing with the Secretary of State a certified copy of every order of repeal of a regulation required to be filed under subdivision (a).

(c)(1) Within 15 days of the office filing a state agency’s regulation with the Secretary of State, post the regulation on its Internet Web site in an easily marked and identifiable location. The state agency shall keep the regulation on its Internet Web site for at least six months from the date the regulation is filed with the Secretary of State.

(2) Within five days of posting, the state agency shall send to the office the Internet Web site link of each regulation that the agency posts on its Internet Web site pursuant to paragraph (1).

(3) This subdivision shall not apply to a state agency that does not maintain an Internet Web site.

(d) Deliver to the office, at the time of transmittal for filing a regulation or order of repeal, six duplicate copies of the regulation or order of repeal, together with a citation of the authority pursuant to which it or any part thereof was adopted.

(e) Deliver to the office a copy of the notice of proposed action required by Section 11346.4.

(f) Transmit to the California Building Standards Commission for approval a certified copy of every regulation, or order of repeal of a regulation, that is a building standard, together with a citation of authority pursuant to which it or any part thereof was adopted, a copy of the notice of proposed action required by Section 11346.4, and any other records prescribed by the State Building Standards Law (Part 2.5 (commencing with Section 18901) of Division 13 of the Health and Safety Code).

(g) Whenever a certification is required by this section, it shall be made by the head of the state agency that is adopting, amending, or repealing the regulation, or by a designee of the agency head, and the certification and delegation shall be in writing.

Added Stats 1979 ch 567 § 1. Amended Stats 1979 ch 1152 § 12.2, operative July 1, 1980; Stats 1980 ch 204 § 1, effective June 20, 1980; Stats 1981 ch 865 § 5; Stats 1982 ch 749 § 1, effective September 8, 1982; Stats 1983 ch 291 § 1; Stats 1987 ch 1375 § 3; Stats 1988 ch 1194 sec 1.2, operative January 1, 1989; Stats 2000 ch 1060 § 9 (AB 1822); Stats 2002 ch 389 § 3 (AB 1857); Stats 2012 ch 295 § 1 (SB 1099), effective January 1, 2013.

**§ 11343.1. Style of regulations; Endorsement**

(a) All regulations transmitted to the Office of Administrative Law for filing with the Secretary of State shall conform to the style prescribed by the office.

(b) Regulations approved by the office shall bear an endorsement by the office affixed to the certified copy which is filed with the Secretary of State.

Added Stats 1983 ch 797 § 2. Amended Stats 1994 ch 1039 § 12 (AB 2531).

**§ 11343.2. Endorsement of time and date of filing and maintenance of file for public inspection**

The Secretary of State shall endorse on the certified copy of each regulation or order of repeal filed with or delivered to him or her, the time and date of filing and shall maintain a permanent file of the certified copies of regulations and orders of repeal for public inspection.

No fee shall be charged by any state officer or public official for the performance of any official act in connection with the certification or filing of regulations pursuant to this article.

Added Stats 1994 ch 1039 § 14 (AB 2531).

**§ 11343.3. Vehicle weight impacts and ability of vehicle manufacturers or operators to comply with laws limiting weight of vehicles to be taken into account when promulgating administrative regulations**

Notwithstanding any other law, a state agency that is required to promulgate administrative regulations, including, but not limited to, the State Air Resources Board, the California Environmental Protection Agency, the State Energy Resources Conservation and Development Commission, and the Department of Motor Vehicles, shall take into account vehicle weight impacts and the ability of vehicle manufacturers or vehicle operators to comply with laws limiting the weight of vehicles.

Added Stats 2012 ch 771 § 2 (AB 1706), effective January 1, 2013.

**§ 11343.4. Effective date of regulation or order of repeal; Applicability**

(a) Except as otherwise provided in subdivision (b), a regulation or an order of repeal required to be filed with the Secretary of State shall become effective on a quarterly basis as follows:

(1) January 1 if the regulation or order of repeal is filed on September 1 to November 30, inclusive.

(2) April 1 if the regulation or order of repeal is filed on December 1 to February 29, inclusive.

(3) July 1 if the regulation or order of repeal is filed on March 1 to May 31, inclusive.

(4) October 1 if the regulation or order of repeal is filed on June 1 to August 31, inclusive.

(b) The effective dates in subdivision (a) shall not apply in all of the following:

(1) The effective date is specifically provided by the statute pursuant to which the regulation or order of repeal was adopted, in which event it becomes effective on the day prescribed by the statute.

(2) A later date is prescribed by the state agency in a written instrument filed with, or as part of, the regulation or order of repeal.

(3) The agency makes a written request to the office demonstrating good cause for an earlier effective date, in which case the office may prescribe an earlier date.

(4)(A) A regulation adopted by the Fish and Game Commission pursuant to Article 1 (commencing with Section 200) of Chapter 2 of Division 1 of the Fish and Game Code.

(B) A regulation adopted by the Fish and Game Commission that requires a different effective date in order to conform to a federal regulation.

Added Stats 1994 ch 1039 § 16 (AB 2531). Amended Stats 2000 ch 1060 § 10 (AB 1822); Stats 2012 ch 295 § 2 (SB 1099), effective January 1, 2013.

**§ 11343.5. Filing copies of Code of Regulations or Regulatory Code Supplement**

Within 10 days from the receipt of printed copies of the California Code of Regulations or of the California Code of Regulations Supplement from the State Printing Office, the office shall file one copy of the particular issue of the code or supplement in the office of the county clerk of each county in this state, or if the authority to accept filings on his or her behalf has been delegated by the county clerk of any county pursuant to Section 26803.5, in the office of the person to whom that authority has been delegated.

Added Stats 1979 ch 567 § 1, operative July 1, 1980, as Gov C § 11343.6. Amended and renumbered by Stats 1981 ch 865 § 9. Amended Stats 1987 ch 1375 § 3.2; Stats 2000 ch 1060 § 11 (AB 1822).

**§ 11343.6. Rebuttable presumptions raised by filing of certified copy**

The filing of a certified copy of a regulation or an order of repeal with the Secretary of State raises the rebuttable presumptions that:

(a) It was duly adopted.

(b) It was duly filed and made available for public inspection at the day and hour endorsed on it.

(c) All requirements of this chapter and the regulations of the office relative to such regulation have been complied with.

(d) The text of the certified copy of a regulation or order of repeal is the text of the regulation or order of repeal as adopted.

The courts shall take judicial notice of the contents of the certified copy of each regulation and of each order of repeal duly filed.

Added Stats 1979 ch 567 § 1, operative July 1, 1980, as Gov C § 11343.7. Renumbered by Stats 1981 ch 865 § 10.

**§ 11343.8. Filing and publication of regulation or order of repeal not required to be filed**

Upon the request of a state agency, the office may file with the Secretary of State and the office may publish in such manner as it believes proper, any regulation or order of repeal of a regulation not required by this article to be filed with the Secretary of State.

Added Stats 1979 ch 567 § 1, operative July 1, 1980, as § 11343.9. Amended and renumbered by Stats 1981 ch 865 § 12.

## ARTICLE 4

### The California Code of Regulations, the California Code of Regulations Supplement, and the California Regulatory Notice Register

#### Section

11344. Publication of Code of Regulations and Code of Regulations Supplement; Availability of regulations on internet
- 11344.1. Publication of Regulatory Notice Register
- 11344.2. Furnishing Code and Supplement to county clerks or delegates
- 11344.3. Time of publication of documents
- 11344.4. Sale of Code, Supplement and Regulatory Notice Register
- 11344.6. Rebuttable presumption raised by publication of regulations
- 11344.7. Authority of state agencies to purchase copies of Code, Supplement, or Register or to print and distribute special editions
- 11344.9. "California Administrative Code"; "California Administrative Notice Register"; "California Administrative Code Supplement"
11345. Identification number not required

#### § 11344. Publication of Code of Regulations and Code of Regulations Supplement; Availability of regulations on internet

The office shall do all of the following:

(a) Provide for the official compilation, printing, and publication of adoption, amendment, or repeal of regulations, which shall be known as the California Code of Regulations. On and after July 1, 1998, the office shall make available on the Internet, free of charge, the full text of the California Code of Regulations, and may contract with another state agency or a private entity in order to provide this service.

(b) Make available on its Internet Web site a list of, and a link to the full text of, each regulation filed with the Secretary of State that is pending effectiveness pursuant to Section 11343.4.

(c) Provide for the compilation, printing, and publication of weekly updates of the California Code of Regulations. This publication shall be known as the California Code of Regulations Supplement and shall contain amendments to the code.

(d) Provide for the publication dates and manner and form in which regulations shall be printed and distributed and ensure that regulations are available in printed form at the earliest practicable date after filing with the Secretary of State.

(e) Ensure that each regulation is printed together with a reference to the statutory authority pursuant to which it was enacted and the specific statute or other provision of law which the regulation is implementing, interpreting, or making specific.

Added Stats 1983 ch 797 § 7. Amended Stats 1987 ch 1375 § 3.5; Stats 1994 ch 1039 § 17 (AB 2531); Stats 1996 ch 501 § 2 (SB 1910); Stats 2000 ch 1060 § 13 (AB 1822); Stats 2012 ch 295 § 3 (SB 1099), effective January 1, 2013.

#### § 11344.1. Publication of Regulatory Notice Register

The office shall do all of the following:

(a) Provide for the publication of the California Regulatory Notice Register, which shall be an official publication of the State of California and which shall contain the following:

(1) Notices of proposed action prepared by regulatory agencies, subject to the notice requirements of this chapter, and which have been approved by the office.

(2) A summary of all regulations filed with the Secretary of State in the previous week.

(3) Summaries of all regulation decisions issued in the previous week detailing the reasons for disapproval of a regulation, the reasons for not filing an emergency regulation, and the reasons for repealing an emergency regulation. The California Regulatory Notice Register shall also include a quarterly index of regulation decisions.

(4) Material that is required to be published under Sections 11349.5, 11349.7, and 11349.9.

(5) Determinations issued pursuant to Section 11340.5.

(b) Establish the publication dates and manner and form in which the California Regulatory Notice Register shall be prepared and published and ensure that it is published and distributed in a timely manner to the presiding officer and rules committee of each house of the Legislature and to all subscribers.

(c) Post on its website, on a weekly basis:

(1) The California Regulatory Notice Register. Each issue of the California Regulatory Notice Register on the office's website shall remain posted for a minimum of 18 months.

(2) One or more Internet links to assist the public to gain access to the text of regulations proposed by state agencies.

Added Stats 1983 ch 797 § 9. Amended Stats 1987 ch 1375 § 4; Stats 1994 ch 1039 § 18 (AB 2531); Stats 2000 ch 1059 § 7 (AB 505), ch 1060 § 14.5 (AB 1822).

#### § 11344.2. Furnishing Code and Supplement to county clerks or delegates

The office shall supply a complete set of the California Code of Regulations, and of the California Code of Regulations Supplement to the county clerk of any county or to the delegatee of the county clerk pursuant to Section 26803.5, provided the director makes the following two determinations:

(a) The county clerk or the delegatee of the county clerk pursuant to Section 26803.5 is maintaining the code and supplement in complete and current condition in a place and at times convenient to the public.

(b) The California Code of Regulations and California Code of Regulations Supplement are not otherwise reasonably available to the public in the community where the county clerk or the delegatee of the county clerk pursuant to Section 26803.5 would normally maintain the code and supplements by distribution to libraries pursuant to Article 6 (commencing with Section 14900) of Chapter 7 of Part 5.5.

Added Stats 1979 ch 567 § 1, operative July 1, 1980. Amended Stats 1979 ch 1203 § 2; Stats 1981 ch 865 § 14; Stats 1987 ch 1375 § 4.5; Stats 2000 ch 1060 § 15 (AB 1822).

#### § 11344.3. Time of publication of documents

Every document, other than a notice of proposed rulemaking action, required to be published in the California Regulatory Notice Register by this chapter, shall be published in the first edition of the California Regu-

latory Notice Register following the date of the document.

Added Stats 1985 ch 1044 § 9 as § 11349.9. Amended and renumbered by Stats 1987 ch 1375 § 23.

**§ 11344.4. Sale of Code, Supplement and Regulatory Notice Register**

(a) The California Code of Regulations, the California Code of Regulations Supplement, and the California Regulatory Notice Register shall be sold at prices which will reimburse the state for all costs incurred for printing, publication, and distribution.

(b) All money received by the state from the sale of the publications listed in subdivision (a) shall be deposited in the treasury and credited to the General Fund, except that, where applicable, an amount necessary to cover the printing, publication, and distribution costs shall be credited to the fund from which the costs have been paid.

Added Stats 1979 ch 567 § 1, operative July 1, 1980. Amended Stats 1979 ch 1203 § 4; Stats 1981 ch 865 § 16; Stats 1987 ch 1375 § 5; Stats 1988 ch 1194 § 1.3, operative January 1, 1989; Stats 2000 ch 1060 § 16 (AB 1822).

**§ 11344.6. Rebuttable presumption raised by publication of regulations**

The publication of a regulation in the California Code of Regulations or California Code of Regulations Supplement raises a rebuttable presumption that the text of the regulation as so published is the text of the regulation adopted.

The courts shall take judicial notice of the contents of each regulation which is printed or which is incorporated by appropriate reference into the California Code of Regulations as compiled by the office.

The courts shall also take judicial notice of the repeal of a regulation as published in the California Code of Regulations Supplement compiled by the office.

Added Stats 1979 ch 567 § 1, operative July 1, 1980, as Gov C § 11343.8. Amended and renumbered Gov C § 11343.7 by Stats 1981 ch 865 § 11. Amended and renumbered by Stats 1983 ch 797 § 5. Amended Stats 1987 ch 1375 § 6; Stats 2000 ch 1060 § 17 (AB 1822).

**§ 11344.7. Authority of state agencies to purchase copies of Code, Supplement, or Register or to print and distribute special editions**

Nothing in this chapter precludes any person or state agency from purchasing copies of the California Code of Regulations, the California Code of Regulations Supplement, or the California Regulatory Notice Register or of any unit of either, nor from printing special editions of any such units and distributing the same. However, where the purchase and printing is by a state agency, the state agency shall do so at the cost or at less than the cost to the agency if it is authorized to do so by other provisions of law.

Added Stats 1979 ch 567 § 1, operative July 1, 1980. Amended Stats 1981 ch 865 § 20; Stats 1987 ch 1375 § 6.5; Stats 2000 ch 1060 § 18 (AB 1822).

**§ 11344.9. “California Administrative Code”; “California Administrative Notice Register”; “California Administrative Code Supplement”**

(a) Whenever the term “California Administrative Code” appears in law, official legal paper, or legal publication, it means the “California Code of Regulations.”

(b) Whenever the term “California Administrative Notice Register” appears in any law, official legal paper, or legal publication, it means the “California Regulatory Notice Register.”

(c) Whenever the term “California Administrative Code Supplement” or “California Regulatory Code Supplement” appears in any law, official legal paper, or legal publication, it means the “California Code of Regulations Supplement.”

Added Stats 1988 ch 1194 § 1, operative January 1, 1989, as Gov C § 11342.02. Renumbered by Stats 1994 ch 1039 § 9 (AB 2531). Amended Stats 2000 ch 1060 § 19 (AB 1822).

**§ 11345. Identification number not required**

The office is not required to develop a unique identification number system for each regulatory action pursuant to Section 11341 or to make the California Regulatory Notice Register available on its website pursuant to subdivision (c) of Section 11344.1 until January 1, 2002.

Added Stats 2000 ch 1059 § 8 (AB 505).

## ARTICLE 5

### Public Participation: Procedure for Adoption of Regulations

Section

- 11346. Purpose and applicability of article; Subsequent legislation
- 11346.1. Emergency regulations and orders of repeal
- 11346.2. Availability to public of copy of proposed regulation; Initial statement of reasons for proposed action
- 11346.3. Assessment of potential for adverse economic impact on businesses and individuals
- 11346.36. Adoption of regulations for conducting standardized regulatory impact analyses; Submission; Publication.
- 11346.4. Notice of proposed action
- 11346.45. Increased public participation
- 11346.5. Contents of notice of proposed adoption, amendment, or repeal of regulation
- 11346.6. Duty of agency, upon request from person with certain disability, to provide narrative description of proposed regulation
- 11346.7. Link on website
- 11346.8. Hearing
- 11346.9. Final statements of reasons for proposing adoption or amendment of regulation; Informative digest
- 11347. Decision not to proceed with proposed action
- 11347.1. Addition to rulemaking file
- 11347.3. File of rulemaking; Contents and availability of file
- 11348. Rulemaking records

**§ 11346. Purpose and applicability of article; Subsequent legislation**

(a) It is the purpose of this chapter to establish basic minimum procedural requirements for the adoption, amendment, or repeal of administrative regulations. Except as provided in Section 11346.1, the provisions of this chapter are applicable to the exercise of any quasi-legislative power conferred by any statute heretofore or hereafter enacted, but nothing in this chapter repeals or diminishes additional requirements imposed by any statute. This chapter shall not be superseded or modified by any subsequent legislation except to the extent that the legislation shall do so expressly.

(b) An agency that is considering adopting, amending, or repealing a regulation may consult with interested persons before initiating regulatory action pursuant to this article.

Added Stats 1979 ch 567 § 1, operative July 1, 1980. Amended Stats 1994 ch 1039 § 20 (AB 2531); Stats 2000 ch 1060 § 20 (AB 1822).



**§ 11346.1. Emergency regulations and orders of repeal**

(a)(1) The adoption, amendment, or repeal of an emergency regulation is not subject to any provision of this article or Article 6 (commencing with Section 11349), except this section and Sections 11349.5 and 11349.6.

(2) At least five working days before submitting an emergency regulation to the office, the adopting agency shall, except as provided in paragraph (3), send a notice of the proposed emergency action to every person who has filed a request for notice of regulatory action with the agency. The notice shall include both of the following:

(A) The specific language proposed to be adopted.

(B) The finding of emergency required by subdivision (b).

(3) An agency is not required to provide notice pursuant to paragraph (2) if the emergency situation clearly poses such an immediate, serious harm that delaying action to allow public comment would be inconsistent with the public interest.

(b)(1) Except as provided in subdivision (c), if a state agency makes a finding that the adoption of a regulation or order of repeal is necessary to address an emergency, the regulation or order of repeal may be adopted as an emergency regulation or order of repeal.

(2) Any finding of an emergency shall include a written statement that contains the information required by paragraphs (2) to (6), inclusive, of subdivision (a) of Section 11346.5 and a description of the specific facts demonstrating the existence of an emergency and the need for immediate action, and demonstrating, by substantial evidence, the need for the proposed regulation to effectuate the statute being implemented, interpreted, or made specific and to address only the demonstrated emergency. The finding of emergency shall also identify each technical, theoretical, and empirical study, report, or similar document, if any, upon which the agency relies. The enactment of an urgency statute shall not, in and of itself, constitute a need for immediate action.

A finding of emergency based only upon expediency, convenience, best interest, general public need, or speculation, shall not be adequate to demonstrate the existence of an emergency. If the situation identified in the finding of emergency existed and was known by the agency adopting the emergency regulation in sufficient time to have been addressed through nonemergency regulations adopted in accordance with the provisions of Article 5 (commencing with Section 11346), the finding of emergency shall include facts explaining the failure to address the situation through nonemergency regulations.

(3) The statement and the regulation or order of repeal shall be filed immediately with the office.

(c) Notwithstanding any other provision of law, no emergency regulation that is a building standard shall be filed, nor shall the building standard be effective, unless the building standard is submitted to the California Building Standards Commission, and is approved and filed pursuant to Sections 18937 and 18938 of the Health and Safety Code.

(d) The emergency regulation or order of repeal shall become effective upon filing or upon any later date specified by the state agency in a written instrument

filed with, or as a part of, the regulation or order of repeal.

(e) No regulation, amendment, or order of repeal initially adopted as an emergency regulatory action shall remain in effect more than 180 days unless the adopting agency has complied with Sections 11346.2 to 11347.3, inclusive, either before adopting an emergency regulation or within the 180-day period. The adopting agency, prior to the expiration of the 180-day period, shall transmit to the office for filing with the Secretary of State the adopted regulation, amendment, or order of repeal, the rulemaking file, and a certification that Sections 11346.2 to 11347.3, inclusive, were complied with either before the emergency regulation was adopted or within the 180-day period.

(f) If an emergency amendment or order of repeal is filed and the adopting agency fails to comply with subdivision (e), the regulation as it existed prior to the emergency amendment or order of repeal shall thereupon become effective and after notice to the adopting agency by the office shall be reprinted in the California Code of Regulations.

(g) If a regulation is originally adopted and filed as an emergency and the adopting agency fails to comply with subdivision (e), this failure shall constitute a repeal of the regulation and after notice to the adopting agency by the office, shall be deleted.

(h) The office may approve not more than two readoptions, each for a period not to exceed 90 days, of an emergency regulation that is the same as or substantially equivalent to an emergency regulation previously adopted by that agency. Readoption shall be permitted only if the agency has made substantial progress and proceeded with diligence to comply with subdivision (e).

Added Stats 1979 ch 567 § 1, operative July 1, 1980. Amended Stats 1979 ch 1152 § 12.4, operative July 1, 1980; Stats 1980 ch 204 § 2, effective June 20, 1980, ch 1238 § 1, effective September 29, 1980; Stats 1981 ch 274 § 7, effective August 27, 1981, ch 865 § 22; Stats 1982 ch 86 § 3, effective March 1, 1982; Stats 1982 ch 86 § 3, effective March 1, 1982, ch 1573 § 2; Stats 1983 ch 797 § 13; Stats 1984 ch 287 § 45, effective July 6, 1984; Stats 1985 ch 956 § 10, effective September 26, 1985; Stats 1987 ch 1375 § 7; Stats 1994 ch 1039 § 21 (AB 2531); Stats 2000 ch 1060 § 21 (AB 1822); Stats 2006 ch 713 § 3 (AB 1302), effective January 1, 2007.

**§ 11346.2. Availability to public of copy of proposed regulation; Initial statement of reasons for proposed action**

Every agency subject to this chapter shall prepare, submit to the office with the notice of the proposed action as described in Section 11346.5, and make available to the public upon request, all of the following:

(a) A copy of the express terms of the proposed regulation.

(1) The agency shall draft the regulation in plain, straightforward language, avoiding technical terms as much as possible, and using a coherent and easily readable style. The agency shall draft the regulation in plain English.

(2) The agency shall include a notation following the express terms of each California Code of Regulations section, listing the specific statutes or other provisions of law authorizing the adoption of the regulation and listing the specific statutes or other provisions of law being implemented, interpreted, or made specific by that section in the California Code of Regulations.

(3) The agency shall use underline or italics to indicate additions to, and strikeout to indicate deletions from, the California Code of Regulations.

(b) An initial statement of reasons for proposing the adoption, amendment, or repeal of a regulation. This statement of reasons shall include, but not be limited to, all of the following:

(1) A statement of the specific purpose of each adoption, amendment, or repeal, the problem the agency intends to address, and the rationale for the determination by the agency that each adoption, amendment, or repeal is reasonably necessary to carry out the purpose and address the problem for which it is proposed. The statement shall enumerate the benefits anticipated from the regulatory action, including the benefits or goals provided in the authorizing statute. These benefits may include, to the extent applicable, nonmonetary benefits such as the protection of public health and safety, worker safety, or the environment, the prevention of discrimination, the promotion of fairness or social equity, and the increase in openness and transparency in business and government, among other things. Where the adoption or amendment of a regulation would mandate the use of specific technologies or equipment, a statement of the reasons why the agency believes these mandates or prescriptive standards are required.

(2) For a major regulation proposed on or after November 1, 2013, the standardized regulatory impact analysis required by Section 11346.3.

(3) An identification of each technical, theoretical, and empirical study, report, or similar document, if any, upon which the agency relies in proposing the adoption, amendment, or repeal of a regulation.

(4)(A) A description of reasonable alternatives to the regulation and the agency's reasons for rejecting those alternatives. Reasonable alternatives to be considered include, but are not limited to, alternatives that are proposed as less burdensome and equally effective in achieving the purposes of the regulation in a manner that ensures full compliance with the authorizing statute or other law being implemented or made specific by the proposed regulation. In the case of a regulation that would mandate the use of specific technologies or equipment or prescribe specific actions or procedures, the imposition of performance standards shall be considered as an alternative.

(B) A description of reasonable alternatives to the regulation that would lessen any adverse impact on small business and the agency's reasons for rejecting those alternatives.

(C) Notwithstanding subparagraph (A) or (B), an agency is not required to artificially construct alternatives or describe unreasonable alternatives.

(5)(A) Facts, evidence, documents, testimony, or other evidence on which the agency relies to support an initial determination that the action will not have a significant adverse economic impact on business.

(B)(i) If a proposed regulation is a building standard, the initial statement of reasons shall include the estimated cost of compliance, the estimated potential benefits, and the related assumptions used to determine the estimates.

(ii) The model codes adopted pursuant to Section 18928 of the Health and Safety Code shall be exempt

from the requirements of this subparagraph. However, if an interested party has made a request in writing to the agency, at least 30 days before the submittal of the initial statement of reasons, to examine a specific section for purposes of estimating the cost of compliance and the potential benefits for that section, and including the related assumptions used to determine the estimates, then the agency shall comply with the requirements of this subparagraph with regard to that requested section.

(6) A department, board, or commission within the Environmental Protection Agency, the Natural Resources Agency, or the Office of the State Fire Marshal shall describe its efforts, in connection with a proposed rulemaking action, to avoid unnecessary duplication or conflicts with federal regulations contained in the Code of Federal Regulations addressing the same issues. These agencies may adopt regulations different from federal regulations contained in the Code of Federal Regulations addressing the same issues upon a finding of one or more of the following justifications:

(A) The differing state regulations are authorized by law.

(B) The cost of differing state regulations is justified by the benefit to human health, public safety, public welfare, or the environment.

(c) A state agency that adopts or amends a regulation mandated by federal law or regulations, the provisions of which are identical to a previously adopted or amended federal regulation, shall be deemed to have complied with subdivision (b) if a statement to the effect that a federally mandated regulation or amendment to a regulation is being proposed, together with a citation to where an explanation of the provisions of the regulation can be found, is included in the notice of proposed adoption or amendment prepared pursuant to Section 11346.5. However, the agency shall comply fully with this chapter with respect to any provisions in the regulation that the agency proposes to adopt or amend that are different from the corresponding provisions of the federal regulation.

(d) This section shall be inoperative from January 1, 2012, until January 1, 2014.

Added Stats 1994 ch 1039 § 23 (AB 2531). Amended Stats 1995 ch 938 § 15.3 (SB 523), operative January 1, 1996; Stats 2000 ch 1059 § 9 (AB 505), ch 1060 § 22.5 (AB 1822); Stats 2002 ch 389 § 4 (AB 1857); Stats 2010 ch 398 § 1 (AB 2738), effective September 27, 2010, inoperative January 1, 2012 until January 1, 2014; Stats 2011 ch 496 § 3 (SB 617), effective January 1, 2012; Stats 2012 ch 471 § 2 (AB 1612), effective January 1, 2013, inoperative January 1, 2012, until January 1, 2014; Stats 2013 ch 212 § 2 (SB 401), effective January 1, 2014, inoperative January 1, 2014.

### § 11346.3. Assessment of potential for adverse economic impact on businesses and individuals

(a) State agencies proposing to adopt, amend, or repeal any administrative regulation shall assess the potential for adverse economic impact on California business enterprises and individuals, avoiding the imposition of unnecessary or unreasonable regulations or reporting, recordkeeping, or compliance requirements. For purposes of this subdivision, assessing the potential for adverse economic impact shall require agencies, when proposing to adopt, amend, or repeal a regulation, to adhere to the following requirements, to

the extent that these requirements do not conflict with other state or federal laws:

(1) The proposed adoption, amendment, or repeal of a regulation shall be based on adequate information concerning the need for, and consequences of, proposed governmental action.

(2) The state agency, prior to submitting a proposal to adopt, amend, or repeal a regulation to the office, shall consider the proposal's impact on business, with consideration of industries affected including the ability of California businesses to compete with businesses in other states. For purposes of evaluating the impact on the ability of California businesses to compete with businesses in other states, an agency shall consider, but not be limited to, information supplied by interested parties.

(3) An economic assessment prepared pursuant to this subdivision for a proposed regulation that is not a major regulation or that is a major regulation proposed prior to November 1, 2013, shall be prepared in accordance with subdivision (b). An economic assessment prepared pursuant to this subdivision for a major regulation proposed on or after November 1, 2013, shall be prepared in accordance with subdivision (c), and shall be included in the initial statement of reasons as required by Section 11346.2.

(b)(1) All state agencies proposing to adopt, amend, or repeal a regulation that is not a major regulation or that is a major regulation proposed prior to November 1, 2013, shall prepare an economic impact assessment that assesses whether and to what extent it will affect the following:

(A) The creation or elimination of jobs within the state.

(B) The creation of new businesses or the elimination of existing businesses within the state.

(C) The expansion of businesses currently doing business within the state.

(D) The benefits of the regulation to the health and welfare of California residents, worker safety, and the state's environment.

(2) This subdivision does not apply to the University of California, the Hastings College of the Law, or the Fair Political Practices Commission.

(3) Information required from state agencies for the purpose of completing the assessment may come from existing state publications.

(c)(1) Each state agency proposing to adopt, amend, or repeal a major regulation on or after November 1, 2013, shall prepare a standardized regulatory impact analysis in the manner prescribed by the Department of Finance pursuant to Section 11346.36. The standardized regulatory impact analysis shall address all of the following:

(A) The creation or elimination of jobs within the state.

(B) The creation of new businesses or the elimination of existing businesses within the state.

(C) The competitive advantages or disadvantages for businesses currently doing business within the state.

(D) The increase or decrease of investment in the state.

(E) The incentives for innovation in products, materials, or processes.

(F) The benefits of the regulations, including, but not limited to, benefits to the health, safety, and welfare of California residents, worker safety, and the state's environment and quality of life, among any other benefits identified by the agency.

(2) This subdivision shall not apply to the University of California, the Hastings College of the Law, or the Fair Political Practices Commission.

(3) Information required from state agencies for the purpose of completing the analysis may be derived from existing state, federal, or academic publications.

(d) Any administrative regulation adopted on or after January 1, 1993, that requires a report shall not apply to businesses, unless the state agency adopting the regulation makes a finding that it is necessary for the health, safety, or welfare of the people of the state that the regulation apply to businesses.

(e) Analyses conducted pursuant to this section are intended to provide agencies and the public with tools to determine whether the regulatory proposal is an efficient and effective means of implementing the policy decisions enacted in statute or by other provisions of law in the least burdensome manner. Regulatory impact analyses shall inform the agencies and the public of the economic consequences of regulatory choices, not reassess statutory policy. The baseline for the regulatory analysis shall be the most cost-effective set of regulatory measures that are equally effective in achieving the purpose of the regulation in a manner that ensures full compliance with the authorizing statute or other law being implemented or made specific by the proposed regulation.

(f) Each state agency proposing to adopt, amend, or repeal a major regulation on or after November 1, 2013, and that has prepared a standardized regulatory impact analysis pursuant to subdivision (c), shall submit that analysis to the Department of Finance upon completion. The department shall comment, within 30 days of receiving that analysis, on the extent to which the analysis adheres to the regulations adopted pursuant to Section 11346.36. Upon receiving the comments from the department, the agency may update its analysis to reflect any comments received from the department and shall summarize the comments and the response of the agency along with a statement of the results of the updated analysis for the statement required by paragraph (10) of subdivision (a) of Section 11346.5.

Added Stats 1994 ch 1039 § 24 (AB 2531). Amended Stats 2000 ch 1059 § 10 (AB 505), ch 1060 § 23 (AB 1822); Stats 2011 ch 496 § 4 (SB 617), effective January 1, 2012; Stats 2012 ch 766 § 2 (SB 1520), effective September 29, 2012.

**§ 11346.36. Adoption of regulations for conducting standardized regulatory impact analyses; Submission; Publication.**

(a) Prior to November 1, 2013, the Department of Finance, in consultation with the office and other state agencies, shall adopt regulations for conducting the standardized regulatory impact analyses required by subdivision (c) of Section 11346.3.

(b) The regulations, at a minimum, shall assist the agencies in specifying the methodologies for:

(1) Assessing and determining the benefits and costs of the proposed regulation, expressed in monetary terms to the extent feasible and appropriate. Assessing the

value of nonmonetary benefits such as the protection of public health and safety, worker safety, or the environment, the prevention of discrimination, the promotion of fairness or social equity, the increase in the openness and transparency of business and government and other nonmonetary benefits consistent with the statutory policy or other provisions of law.

(2) Comparing proposed regulatory alternatives with an established baseline so agencies can make analytical decisions for the adoption, amendment, or repeal of regulations necessary to determine that the proposed action is the most effective, or equally effective and less burdensome, alternative in carrying out the purpose for which the action is proposed, or the most cost-effective alternative to the economy and to affected private persons that would be equally effective in implementing the statutory policy or other provision of law.

(3) Determining the impact of a regulatory proposal on the state economy, businesses, and the public welfare, as described in subdivision (c) of Section 11346.3.

(4) Assessing the effects of a regulatory proposal on the General Fund and special funds of the state and affected local government agencies attributable to the proposed regulation.

(5) Determining the cost of enforcement and compliance to the agency and to affected business enterprises and individuals.

(6) Making the estimation described in Section 11342.548.

(c) To the extent required by this chapter, the department shall convene a public hearing or hearings and take public comment on any draft regulation. Representatives from state agencies and the public at large shall be afforded the opportunity to review and comment on the draft regulation before the regulation is adopted in final form.

(d) State agencies shall provide the Director of Finance and the office ready access to their records and full information and reasonable assistance in any matter requested for purposes of developing the regulations required by this section. This subdivision shall not be construed to authorize an agency to provide access to records required by statute to be kept confidential.

(e) The standardized regulatory impact analysis prepared by the proposing agency shall be included in the initial statement of reasons for the regulation as provided in subdivision (b) of Section 11346.2.

(f) On or before November 1, 2013, the department shall submit the adopted regulations to the Senate and Assembly Committees on Governmental Organization and shall publish the adopted regulations in the State Administrative Manual.

Added Stats 2011 ch 496 § 5 (SB 617), effective January 1, 2012.

#### § 11346.4. Notice of proposed action

(a) At least 45 days prior to the hearing and close of the public comment period on the adoption, amendment, or repeal of a regulation, notice of the proposed action shall be:

(1) Mailed to every person who has filed a request for notice of regulatory actions with the state agency. Each state agency shall give a person filing a request for notice of regulatory actions the option of being notified of all

proposed regulatory actions or being notified of regulatory actions concerning one or more particular programs of the state agency.

(2) In cases in which the state agency is within a state department, mailed or delivered to the director of the department.

(3) Mailed to a representative number of small business enterprises or their representatives that are likely to be affected by the proposed action. "Representative" for the purposes of this paragraph includes, but is not limited to, a trade association, industry association, professional association, or any other business group or association of any kind that represents a business enterprise or employees of a business enterprise.

(4) When appropriate in the judgment of the state agency, mailed to any person or group of persons whom the agency believes to be interested in the proposed action and published in the form and manner as the state agency shall prescribe.

(5) Published in the California Regulatory Notice Register as prepared by the office for each state agency's notice of regulatory action.

(6) Posted on the state agency's website if the agency has a website.

(b) The effective period of a notice issued pursuant to this section shall not exceed one year from the date thereof. If the adoption, amendment, or repeal of a regulation proposed in the notice is not completed and transmitted to the office within the period of one year, a notice of the proposed action shall again be issued pursuant to this article.

(c) Once the adoption, amendment, or repeal is completed and approved by the office, no further adoption, amendment, or repeal to the noticed regulation shall be made without subsequent notice being given.

(d) The office may refuse to publish a notice submitted to it if the agency has failed to comply with this article.

(e) The office shall make the California Regulatory Notice Register available to the public and state agencies at a nominal cost that is consistent with a policy of encouraging the widest possible notice distribution to interested persons.

(f) Where the form or manner of notice is prescribed by statute in any particular case, in addition to filing and mailing notice as required by this section, the notice shall be published, posted, mailed, filed, or otherwise publicized as prescribed by that statute. The failure to mail notice to any person as provided in this section shall not invalidate any action taken by a state agency pursuant to this article.

Added Stats 1979 ch 567 § 1, operative July 1, 1980. Amended Stats 1979 ch 1203 § 5; Stats 1981 ch 865 § 24; Stats 1982 ch 1083 § 3; Stats 1985 ch 1044 § 1; Stats 1987 ch 1375 § 9; Stats 1994 ch 1039 § 25 (AB 2531); Stats 2000 ch 1059 § 11 (AB 505).

#### § 11346.45. Increased public participation

(a) In order to increase public participation and improve the quality of regulations, state agencies proposing to adopt regulations shall, prior to publication of the notice required by Section 11346.5, involve parties who would be subject to the proposed regulations in public discussions regarding those proposed regulations, when the proposed regulations involve complex proposals or a

large number of proposals that cannot easily be reviewed during the comment period.

(b) This section does not apply to a state agency in any instance where that state agency is required to implement federal law and regulations for which there is little or no discretion on the part of the state to vary.

(c) If the agency does not or cannot comply with the provisions of subdivision (a), it shall state the reasons for noncompliance with reasonable specificity in the rule-making record.

(d) The provisions of this section shall not be subject to judicial review or to the provisions of Section 11349.1. Added Stats 2000 ch 1059 § 12 (AB 505).

**§ 11346.5. Contents of notice of proposed adoption, amendment, or repeal of regulation**

(a) The notice of proposed adoption, amendment, or repeal of a regulation shall include the following:

(1) A statement of the time, place, and nature of proceedings for adoption, amendment, or repeal of the regulation.

(2) Reference to the authority under which the regulation is proposed and a reference to the particular code sections or other provisions of law that are being implemented, interpreted, or made specific.

(3) An informative digest drafted in plain English in a format similar to the Legislative Counsel's digest on legislative bills. The informative digest shall include the following:

(A) A concise and clear summary of existing laws and regulations, if any, related directly to the proposed action and of the effect of the proposed action.

(B) If the proposed action differs substantially from an existing comparable federal regulation or statute, a brief description of the significant differences and the full citation of the federal regulations or statutes.

(C) A policy statement overview explaining the broad objectives of the regulation and the specific benefits anticipated by the proposed adoption, amendment, or repeal of a regulation, including, to the extent applicable, nonmonetary benefits such as the protection of public health and safety, worker safety, or the environment, the prevention of discrimination, the promotion of fairness or social equity, and the increase in openness and transparency in business and government, among other things.

(D) An evaluation of whether the proposed regulation is inconsistent or incompatible with existing state regulations.

(4) Any other matters as are prescribed by statute applicable to the specific state agency or to any specific regulation or class of regulations.

(5) A determination as to whether the regulation imposes a mandate on local agencies or school districts and, if so, whether the mandate requires state reimbursement pursuant to Part 7 (commencing with Section 17500) of Division 4.

(6) An estimate, prepared in accordance with instructions adopted by the Department of Finance, of the cost or savings to any state agency, the cost to any local agency or school district that is required to be reimbursed under Part 7 (commencing with Section 17500) of Division 4, other nondiscretionary cost or savings im-

posed on local agencies, and the cost or savings in federal funding to the state.

For purposes of this paragraph, "cost or savings" means additional costs or savings, both direct and indirect, that a public agency necessarily incurs in reasonable compliance with regulations.

(7) If a state agency, in proposing to adopt, amend, or repeal any administrative regulation, makes an initial determination that the action may have a significant, statewide adverse economic impact directly affecting business, including the ability of California businesses to compete with businesses in other states, it shall include the following information in the notice of proposed action:

(A) Identification of the types of businesses that would be affected.

(B) A description of the projected reporting, record-keeping, and other compliance requirements that would result from the proposed action.

(C) The following statement: "The (name of agency) has made an initial determination that the (adoption/amendment/repeal) of this regulation may have a significant, statewide adverse economic impact directly affecting business, including the ability of California businesses to compete with businesses in other states. The (name of agency) (has/has not) considered proposed alternatives that would lessen any adverse economic impact on business and invites you to submit proposals. Submissions may include the following considerations:

(i) The establishment of differing compliance or reporting requirements or timetables that take into account the resources available to businesses.

(ii) Consolidation or simplification of compliance and reporting requirements for businesses.

(iii) The use of performance standards rather than prescriptive standards.

(iv) Exemption or partial exemption from the regulatory requirements for businesses."

(8) If a state agency, in adopting, amending, or repealing any administrative regulation, makes an initial determination that the action will not have a significant, statewide adverse economic impact directly affecting business, including the ability of California businesses to compete with businesses in other states, it shall make a declaration to that effect in the notice of proposed action. In making this declaration, the agency shall provide in the record facts, evidence, documents, testimony, or other evidence upon which the agency relies to support its initial determination.

An agency's initial determination and declaration that a proposed adoption, amendment, or repeal of a regulation may have or will not have a significant, adverse impact on businesses, including the ability of California businesses to compete with businesses in other states, shall not be grounds for the office to refuse to publish the notice of proposed action.

(9) A description of all cost impacts, known to the agency at the time the notice of proposed action is submitted to the office, that a representative private person or business would necessarily incur in reasonable compliance with the proposed action.

If no cost impacts are known to the agency, it shall state the following:

“The agency is not aware of any cost impacts that a representative private person or business would necessarily incur in reasonable compliance with the proposed action.”

(10) A statement of the results of the economic impact assessment required by subdivision (b) of Section 11346.3 or the standardized regulatory impact analysis if required by subdivision (c) of Section 11346.3, a summary of any comments submitted to the agency pursuant to subdivision (f) of Section 11346.3 and the agency’s response to those comments.

(11) The finding prescribed by subdivision (d) of Section 11346.3, if required.

(12)(A) A statement that the action would have a significant effect on housing costs, if a state agency, in adopting, amending, or repealing any administrative regulation, makes an initial determination that the action would have that effect.

(B) The agency officer designated in paragraph (14) shall make available to the public, upon request, the agency’s evaluation, if any, of the effect of the proposed regulatory action on housing costs.

(C) The statement described in subparagraph (A) shall also include the estimated costs of compliance and potential benefits of a building standard, if any, that were included in the initial statement of reasons.

(D) For purposes of model codes adopted pursuant to Section 18928 of the Health and Safety Code, the agency shall comply with the requirements of this paragraph only if an interested party has made a request to the agency to examine a specific section for purposes of estimating the costs of compliance and potential benefits for that section, as described in Section 11346.2.

(13) A statement that the adopting agency must determine that no reasonable alternative considered by the agency or that has otherwise been identified and brought to the attention of the agency would be more effective in carrying out the purpose for which the action is proposed, would be as effective and less burdensome to affected private persons than the proposed action, or would be more cost effective to affected private persons and equally effective in implementing the statutory policy or other provision of law. For a major regulation, as defined by Section 11342.548, proposed on or after November 1, 2013, the statement shall be based, in part, upon the standardized regulatory impact analysis of the proposed regulation, as required by Section 11346.3, as well as upon the benefits of the proposed regulation identified pursuant to subparagraph (C) of paragraph (3).

(14) The name and telephone number of the agency representative and designated backup contact person to whom inquiries concerning the proposed administrative action may be directed.

(15) The date by which comments submitted in writing must be received to present statements, arguments, or contentions in writing relating to the proposed action in order for them to be considered by the state agency before it adopts, amends, or repeals a regulation.

(16) Reference to the fact that the agency proposing the action has prepared a statement of the reasons for the proposed action, has available all the information upon which its proposal is based, and has available the

express terms of the proposed action, pursuant to subdivision (b).

(17) A statement that if a public hearing is not scheduled, any interested person or his or her duly authorized representative may request, no later than 15 days prior to the close of the written comment period, a public hearing pursuant to Section 11346.8.

(18) A statement indicating that the full text of a regulation changed pursuant to Section 11346.8 will be available for at least 15 days prior to the date on which the agency adopts, amends, or repeals the resulting regulation.

(19) A statement explaining how to obtain a copy of the final statement of reasons once it has been prepared pursuant to subdivision (a) of Section 11346.9.

(20) If the agency maintains an Internet Web site or other similar forum for the electronic publication or distribution of written material, a statement explaining how materials published or distributed through that forum can be accessed.

(21) If the proposed regulation is subject to Section 11346.6, a statement that the agency shall provide, upon request, a description of the proposed changes included in the proposed action, in the manner provided by Section 11346.6, to accommodate a person with a visual or other disability for which effective communication is required under state or federal law and that providing the description of proposed changes may require extending the period of public comment for the proposed action.

(b) The agency representative designated in paragraph (14) of subdivision (a) shall make available to the public upon request the express terms of the proposed action. The representative shall also make available to the public upon request the location of public records, including reports, documentation, and other materials, related to the proposed action. If the representative receives an inquiry regarding the proposed action that the representative cannot answer, the representative shall refer the inquiry to another person in the agency for a prompt response.

(c) This section shall not be construed in any manner that results in the invalidation of a regulation because of the alleged inadequacy of the notice content or the summary or cost estimates, or the alleged inadequacy or inaccuracy of the housing cost estimates, if there has been substantial compliance with those requirements.

Added Stats 1979 ch 567 § 1, operative July 1, 1980. Amended Stats 1979 ch 1203 § 6; Stats 1981 ch 865 § 25; Stats 1982 ch 327 § 30, effective June 30, 1982; Stats 1983 ch 797 § 15; Stats 1986 ch 879 § 1; Stats 1987 ch 1375 § 10; Stats 1993 ch 1046 § 1 (AB 1144); Stats 1994 ch 1039 § 26 (AB 2531); Stats 2000 ch 1059 § 13 (AB 505), ch 1060 § 24.5 (AB 1822); Stats 2002 ch 389 § 5 (AB 1857); Stats 2011 ch 495 § 2 (AB 410), ch 496 § 6 (SB 617), effective January 1, 2012; Stats 2012 ch 471 § 3 (AB 1612), effective January 1, 2013, ch 723 § 1.5 (AB 2041), effective January 1, 2013.

**§ 11346.6. Duty of agency, upon request from person with certain disability, to provide narrative description of proposed regulation**

(a) This section shall only apply to the following proposed regulations:

(1) Regulations proposed by the Department of Rehabilitation.

(2) Regulations that must be submitted to the California Building Standards Commission that pertain to

disability access compliance, including, but not limited to, regulations proposed by the State Fire Marshal, the Department of Housing and Community Development, the Division of the State Architect, and the California Commission on Disability Access.

(3) Regulations proposed by the State Department of Education that pertain to special education.

(4) Regulations proposed by the State Department of Health Care Services that pertain to the Medi-Cal program.

(b) Upon request from a person with a visual disability or other disability for which effective communication is required under state or federal law, the agency shall provide that person a narrative description of the additions to, and deletions from, the California Code of Regulations or other publication. The description shall identify each addition to or deletion from the California Code of Regulations by reference to the subdivision, paragraph, subparagraph, clause, or subclause within the proposed regulation containing the addition or deletion. The description shall provide the express language proposed to be added to or deleted from the California Code of Regulations or other publication and any portion of the surrounding language necessary to understand the change in a manner that allows for accurate translation by reading software used by the visually impaired.

(c) The agency shall provide the information described in subdivision (b) within 10 business days, unless the agency determines that compliance with this requirement would be impractical and notifies the requester of the date on which the information will be provided.

(d) Notwithstanding any other law, if information is provided to a requester pursuant to this section, the agency shall provide that requester at least 45 days from the date upon which the information was provided to the requester to submit a public comment regarding the proposed regulation. The agency shall not take final action to adopt the regulation until the requester has submitted a public comment or the extended 45-day comment period expires, whichever occurs first.

(e) The requirements imposed pursuant to subdivisions (b) to (d), inclusive, for a proposed regulation described in subdivision (a) shall apply to an agency only for purposes of that proposed regulation until the proposed regulation is filed with the Secretary of State or until the agency otherwise concludes the regulatory adoption process.

(f)(1) Not later than February 1, 2014, an agency that adopted a proposed regulation subject to the requirements of this section shall submit a report, for both the 2012 and 2013 calendar years, to the Governor, the fiscal committee in each house of the Legislature, and the appropriate policy committee in each house of the Legislature, that specifies the number of requests submitted for a narrative description of a proposed regulation, and the number of narrative descriptions actually provided pursuant to this section.

(2) The report shall be submitted to the Legislature in the manner required pursuant to Section 9795.

(3) The reporting requirement imposed by this subdivision shall become inoperative on February 1, 2018, as required pursuant to Section 10231.5.

(4) It is the intent of the Legislature to evaluate the reports submitted pursuant to this subdivision to deter-

mine whether the requirements of this section should be applied to all regulations adopted by all agencies.

Added Stats 2011 ch 495 § 3 (AB 410), effective January 1, 2012.

#### § 11346.7. Link on website

The office shall maintain a link on its website to the website maintained by the Small Business Advocate that also includes the telephone number of the Small Business Advocate.

Added Stats 2000 ch 1059 § 17 (AB 505).

#### § 11346.8. Hearing

(a) If a public hearing is held, both oral and written statements, arguments, or contentions, shall be permitted. The agency may impose reasonable limitations on oral presentations. If a public hearing is not scheduled, the state agency shall, consistent with Section 11346.4, afford any interested person or his or her duly authorized representative, the opportunity to present statements, arguments or contentions in writing. In addition, a public hearing shall be held if, no later than 15 days prior to the close of the written comment period, an interested person or his or her duly authorized representative submits in writing to the state agency, a request to hold a public hearing. The state agency shall, to the extent practicable, provide notice of the time, date, and place of the hearing by mailing the notice to every person who has filed a request for notice thereby with the state agency. The state agency shall consider all relevant matter presented to it before adopting, amending, or repealing any regulation.

(b) In any hearing under this section, the state agency or its duly authorized representative shall have authority to administer oaths or affirmations. An agency may continue or postpone a hearing from time to time to the time and at the place as it determines. If a hearing is continued or postponed, the state agency shall provide notice to the public as to when it will be resumed or rescheduled.

(c) No state agency may adopt, amend, or repeal a regulation which has been changed from that which was originally made available to the public pursuant to Section 11346.5, unless the change is (1) nonsubstantial or solely grammatical in nature, or (2) sufficiently related to the original text that the public was adequately placed on notice that the change could result from the originally proposed regulatory action. If a sufficiently related change is made, the full text of the resulting adoption, amendment, or repeal, with the change clearly indicated, shall be made available to the public for at least 15 days before the agency adopts, amends, or repeals the resulting regulation. Any written comments received regarding the change must be responded to in the final statement of reasons required by Section 11346.9.

(d) No state agency shall add any material to the record of the rulemaking proceeding after the close of the public hearing or comment period, unless the agency complies with Section 11347.1. This subdivision does not apply to material prepared pursuant to Section 11346.9.

(e) If a comment made at a public hearing raises a new issue concerning a proposed regulation and a member of the public requests additional time to respond to

the new issue before the state agency takes final action, it is the intent of the Legislature that rulemaking agencies consider granting the request for additional time if, under the circumstances, granting the request is practical and does not unduly delay action on the regulation.

Added Stats 1981 ch 865 § 29. Amended Stats 1981 ch 1091 § 2; Stats 1982 ch 86 § 4, effective March 1, 1982; Stats 1983 ch 797 § 19; Stats 1987 ch 1375 § 15; Stats 1994 ch 1039 § 32 (AB 2531); Stats 2000 ch 1059 § 16 (AB 505), ch 1060 § 26.5 (AB 1822).

**§ 11346.9. Final statements of reasons for proposing adoption or amendment of regulation; Informative digest**

Every agency subject to this chapter shall do the following:

(a) Prepare and submit to the office with the adopted regulation a final statement of reasons that shall include all of the following:

(1) An update of the information contained in the initial statement of reasons. If the update identifies any data or any technical, theoretical or empirical study, report, or similar document on which the agency is relying in proposing the adoption, amendment, or repeal of a regulation that was not identified in the initial statement of reasons, or which was otherwise not identified or made available for public review prior to the close of the public comment period, the agency shall comply with Section 11347.1.

(2) A determination as to whether adoption, amendment, or repeal of the regulation imposes a mandate on local agencies or school districts. If the determination is that adoption, amendment, or repeal of the regulation would impose a local mandate, the agency shall state whether the mandate is reimbursable pursuant to Part 7 (commencing with Section 17500) of Division 4. If the agency finds that the mandate is not reimbursable, it shall state the reasons for that finding.

(3) A summary of each objection or recommendation made regarding the specific adoption, amendment, or repeal proposed, together with an explanation of how the proposed action has been changed to accommodate each objection or recommendation, or the reasons for making no change. This requirement applies only to objections or recommendations specifically directed at the agency's proposed action or to the procedures followed by the agency in proposing or adopting the action. The agency may aggregate and summarize repetitive or irrelevant comments as a group, and may respond to repetitive comments or summarily dismiss irrelevant comments as a group. For the purposes of this paragraph, a comment is "irrelevant" if it is not specifically directed at the agency's proposed action or to the procedures followed by the agency in proposing or adopting the action.

(4) A determination with supporting information that no alternative considered by the agency would be more effective in carrying out the purpose for which the regulation is proposed, would be as effective and less burdensome to affected private persons than the adopted regulation, or would be more cost effective to affected private persons and equally effective in implementing the statutory policy or other provision of law. For a major regulation, as defined by Section 11342.548 proposed on or after November 1, 2013, the determination shall be

based, in part, upon the standardized regulatory impact analysis of the proposed regulation and, in part, upon the statement of benefits identified in subparagraph (C) of paragraph (3) of subdivision (a) of Section 11346.5.

(5) An explanation setting forth the reasons for rejecting any proposed alternatives that would lessen the adverse economic impact on small businesses. The agency shall include, as supporting information, the standardized regulatory impact analysis for a major regulation, if required by subdivision (c) of Section 11346.3, as well as the benefits of the proposed regulation identified pursuant to paragraph (3) of subdivision (a) of Section 11346.5.

(b) Prepare and submit to the office with the adopted regulation an updated informative digest containing a clear and concise summary of the immediately preceding laws and regulations, if any, relating directly to the adopted, amended, or repealed regulation and the effect of the adopted, amended, or repealed regulation. The informative digest shall be drafted in a format similar to the Legislative Counsel's Digest on legislative bills.

(c) A state agency that adopts or amends a regulation mandated by federal law or regulations, the provisions of which are identical to a previously adopted or amended federal regulation, shall be deemed to have complied with this section if a statement to the effect that a federally mandated regulation or amendment to a regulation is being proposed, together with a citation to where an explanation of the provisions of the regulation can be found, is included in the notice of proposed adoption or amendment prepared pursuant to Section 11346.5. However, the agency shall comply fully with this chapter with respect to any provisions in the regulation which the agency proposes to adopt or amend that are different from the corresponding provisions of the federal regulation.

(d) If an agency determines that a requirement of this section can be satisfied by reference to an agency statement made pursuant to Sections 11346.2 to 11346.5, inclusive, the agency may satisfy the requirement by incorporating the relevant statement by reference.

Added Stats 1994 ch 1039 § 33 (AB 2531). Amended Stats 2000 ch 1060 § 27 (AB 1822); Stats 2011 ch 496 § 7 (SB 617), effective January 1, 2012.

**§ 11347. Decision not to proceed with proposed action**

(a) If, after publication of a notice of proposed action pursuant to Section 11346.4, but before the notice of proposed action becomes ineffective pursuant to subdivision (b) of that section, an agency decides not to proceed with the proposed action, it shall deliver notice of its decision to the office for publication in the California Regulatory Notice Register.

(b) Publication of a notice under this section terminates the effect of the notice of proposed action referred to in the notice. Nothing in this section precludes an agency from proposing a new regulatory action that is similar or identical to a regulatory action that was previously the subject of a notice published under this section.

Added Stats 2000 ch 1059 § 17 (AB 505), ch 1060 § 28 (AB 1822).

**§ 11347.1. Addition to rulemaking file**

(a) An agency that adds any technical, theoretical, or empirical study, report, or similar document to the



rulemaking file after publication of the notice of proposed action and relies on the document in proposing the action shall make the document available as required by this section.

(b) At least 15 calendar days before the proposed action is adopted by the agency, the agency shall mail to all of the following persons a notice identifying the added document and stating the place and business hours that the document is available for public inspection:

- (1) Persons who testified at the public hearing.
- (2) Persons who submitted written comments at the public hearing.
- (3) Persons whose comments were received by the agency during the public comment period.
- (4) Persons who requested notification from the agency of the availability of changes to the text of the proposed regulation.

(c) The document shall be available for public inspection at the location described in the notice for at least 15 calendar days before the proposed action is adopted by the agency.

(d) Written comments on the document or information received by the agency during the availability period shall be summarized and responded to in the final statement of reasons as provided in Section 11346.9.

(e) The rulemaking file shall contain a statement confirming that the agency complied with the requirements of this section and stating the date on which the notice was mailed.

(f) If there are no persons in categories listed in subdivision (b), then the rulemaking file shall contain a confirming statement to that effect.

Added Stats 2000 ch 1060 § 29 (AB 1822).

### § 11347.3. File of rulemaking; Contents and availability of file

(a) Every agency shall maintain a file of each rulemaking that shall be deemed to be the record for that rulemaking proceeding. Commencing no later than the date that the notice of the proposed action is published in the California Regulatory Notice Register, and during all subsequent periods of time that the file is in the agency's possession, the agency shall make the file available to the public for inspection and copying during regular business hours.

(b) The rulemaking file shall include:

(1) Copies of any petitions received from interested persons proposing the adoption, amendment, or repeal of the regulation, and a copy of any decision provided for by subdivision (d) of Section 11340.7, which grants a petition in whole or in part.

(2) All published notices of proposed adoption, amendment, or repeal of the regulation, and an updated informative digest, the initial statement of reasons, and the final statement of reasons.

(3) The determination, together with the supporting data required by paragraph (5) of subdivision (a) of Section 11346.5.

(4) The determination, together with the supporting data required by paragraph (8) of subdivision (a) of Section 11346.5.

(5) The estimate, together with the supporting data and calculations, required by paragraph (6) of subdivision (a) of Section 11346.5.

(6) All data and other factual information, any studies or reports, and written comments submitted to the agency in connection with the adoption, amendment, or repeal of the regulation.

(7) All data and other factual information, technical, theoretical, and empirical studies or reports, if any, on which the agency is relying in the adoption, amendment, or repeal of a regulation, including any economic impact assessment or standardized regulatory impact analysis as required by Section 11346.3.

(8) A transcript, recording, or minutes of any public hearing connected with the adoption, amendment, or repeal of the regulation.

(9) The date on which the agency made the full text of the proposed regulation available to the public for 15 days prior to the adoption, amendment, or repeal of the regulation, if required to do so by subdivision (c) of Section 11346.8.

(10) The text of regulations as originally proposed and the modified text of regulations, if any, that were made available to the public prior to adoption.

(11) Any other information, statement, report, or data that the agency is required by law to consider or prepare in connection with the adoption, amendment, or repeal of a regulation.

(12) An index or table of contents that identifies each item contained in the rulemaking file. The index or table of contents shall include an affidavit or a declaration under penalty of perjury in the form specified by Section 2015.5 of the Code of Civil Procedure by the agency official who has compiled the rulemaking file, specifying the date upon which the record was closed, and that the file or the copy, if submitted, is complete.

(c) Every agency shall submit to the office with the adopted regulation, the rulemaking file or a complete copy of the rulemaking file.

(d) The rulemaking file shall be made available by the agency to the public, and to the courts in connection with the review of the regulation.

(e) Upon filing a regulation with the Secretary of State pursuant to Section 11349.3, the office shall return the related rulemaking file to the agency, after which no item contained in the file shall be removed, altered, or destroyed or otherwise disposed of. The agency shall maintain the file unless it elects to transmit the file to the State Archives pursuant to subdivision (f).

(f) The agency may transmit the rulemaking file to the State Archives. The file shall include instructions that the Secretary of State shall not remove, alter, or destroy or otherwise dispose of any item contained in the file. Pursuant to Section 12223.5, the Secretary of State may designate a time for the delivery of the rulemaking file to the State Archives in consideration of document processing or storage limitations.

Added Stats 1979 ch 567 § 1, operative July 1, 1980. Amended Stats 1979 ch 1203 § 8; Stats 1981 ch 865 § 31; Stats 1982 ch 327 § 35, effective June 30, 1982; Stats 1983 ch 797 § 21; Stats 1984 ch 1444 § 5, effective September 26, 1984; Stats 1987 ch 1375 § 16; Stats 1991 ch 899 § 3 (SB 327), effective October 12, 1991; Stats 1994 ch 1039 § 36 (AB 2531); Stats 1996 ch 928 § 3 (SB 1507); Stats 2000 ch 1060 § 30 (AB 1822); 2011 ch 496 § 8 (SB 617), effective January 1, 2012.

### § 11348. Rulemaking records

Each agency subject to this chapter shall keep its rulemaking records on all of that agency's pending

rulemaking actions, in which the notice has been published in the California Regulatory Notice Register, current and in one central location.

Added Stats 2000 ch 1059 § 19 (AB 505).

## ARTICLE 6

### Review of Proposed Regulations

#### Section

11349. Definitions

11349.1. Review of regulations; Regulations to govern review process; Return to adopting agency

11349.1.5. Review of standardized regulatory impact analyses; Report; Notice of noncompliance.

11349.2. Adding material to file

11349.3. Time for review of regulations; Procedure on disapproval; Return of regulations

11349.4. Rewriting and resubmission of regulation; Review

11349.5. Governor's review of decisions

11349.6. Review by office of emergency regulation

#### § 11349. Definitions

The following definitions govern the interpretation of this chapter:

(a) "Necessity" means the record of the rulemaking proceeding demonstrates by substantial evidence the need for a regulation to effectuate the purpose of the statute, court decision, or other provision of law that the regulation implements, interprets, or makes specific, taking into account the totality of the record. For purposes of this standard, evidence includes, but is not limited to, facts, studies, and expert opinion.

(b) "Authority" means the provision of law which permits or obligates the agency to adopt, amend, or repeal a regulation.

(c) "Clarity" means written or displayed so that the meaning of regulations will be easily understood by those persons directly affected by them.

(d) "Consistency" means being in harmony with, and not in conflict with or contradictory to, existing statutes, court decisions, or other provisions of law.

(e) "Reference" means the statute, court decision, or other provision of law which the agency implements, interprets, or makes specific by adopting, amending, or repealing a regulation.

(f) "Nonduplication" means that a regulation does not serve the same purpose as a state or federal statute or another regulation. This standard requires that an agency proposing to amend or adopt a regulation must identify any state or federal statute or regulation which is overlapped or duplicated by the proposed regulation and justify any overlap or duplication. This standard is not intended to prohibit state agencies from printing relevant portions of enabling legislation in regulations when the duplication is necessary to satisfy the clarity standard in paragraph (3) of subdivision (a) of Section 11349.1. This standard is intended to prevent the indiscriminate incorporation of statutory language in a regulation.

Added Stats 1979 ch 567 § 1, operative July 1, 1980. Amended Stats 1981 ch 983 § 4; Stats 1982 ch 1573 § 4; Stats 1983 ch 797 § 22; Stats 1985 ch 1044 § 3; Stats 1994 ch 1039 § 39 (AB 2531); Stats 2000 ch 1060 § 31 (AB 1822).

#### § 11349.1. Review of regulations; Regulations to govern review process; Return to adopting agency

(a) The office shall review all regulations adopted, amended, or repealed pursuant to the procedure specified in Article 5 (commencing with Section 11346) and submitted to it for publication in the California Code of Regulations Supplement and for transmittal to the Secretary of State and make determinations using all of the following standards:

- (1) Necessity.
- (2) Authority.
- (3) Clarity.
- (4) Consistency.
- (5) Reference.
- (6) Nonduplication.

In reviewing regulations pursuant to this section, the office shall restrict its review to the regulation and the record of the rulemaking proceeding. The office shall approve the regulation or order of repeal if it complies with the standards set forth in this section and with this chapter.

(b) In reviewing proposed regulations for the criteria in subdivision (a), the office may consider the clarity of the proposed regulation in the context of related regulations already in existence.

(c) The office shall adopt regulations governing the procedures it uses in reviewing regulations submitted to it. The regulations shall provide for an orderly review and shall specify the methods, standards, presumptions, and principles the office uses, and the limitations it observes, in reviewing regulations to establish compliance with the standards specified in subdivision (a). The regulations adopted by the office shall ensure that it does not substitute its judgment for that of the rulemaking agency as expressed in the substantive content of adopted regulations.

(d) The office shall return any regulation subject to this chapter to the adopting agency if any of the following occur:

(1) The adopting agency has not prepared the estimate required by paragraph (6) of subdivision (a) of Section 11346.5 and has not included the data used and calculations made and the summary report of the estimate in the file of the rulemaking.

(2) The agency has not complied with Section 11346.3. "Noncompliance" means that the agency failed to complete the economic impact assessment or standardized regulatory impact analysis required by Section 11346.3 or failed to include the assessment or analysis in the file of the rulemaking proceeding as required by Section 11347.3.

(3) The adopting agency has prepared the estimate required by paragraph (6) of subdivision (a) of Section 11346.5, the estimate indicates that the regulation will result in a cost to local agencies or school districts that is required to be reimbursed under Part 7 (commencing with Section 17500) of Division 4, and the adopting agency fails to do any of the following:

(A) Cite an item in the Budget Act for the fiscal year in which the regulation will go into effect as the source from which the Controller may pay the claims of local agencies or school districts.

(B) Cite an accompanying bill appropriating funds as the source from which the Controller may pay the claims of local agencies or school districts.

(C) Attach a letter or other documentation from the Department of Finance which states that the Department of Finance has approved a request by the agency that funds be included in the Budget Bill for the next following fiscal year to reimburse local agencies or school districts for the costs mandated by the regulation.

(D) Attach a letter or other documentation from the Department of Finance which states that the Department of Finance has authorized the augmentation of the amount available for expenditure under the agency's appropriation in the Budget Act which is for reimbursement pursuant to Part 7 (commencing with Section 17500) of Division 4 to local agencies or school districts from the unencumbered balances of other appropriations in the Budget Act and that this augmentation is sufficient to reimburse local agencies or school districts for their costs mandated by the regulation.

(4) The proposed regulation conflicts with an existing state regulation and the agency has not identified the manner in which the conflict may be resolved.

(5) The agency did not make the alternatives determination as required by paragraph (4) of subdivision (a) of Section 11346.9.

(e) The office shall notify the Department of Finance of all regulations returned pursuant to subdivision (d).

(f) The office shall return a rulemaking file to the submitting agency if the file does not comply with subdivisions (a) and (b) of Section 11347.3. Within three state working days of the receipt of a rulemaking file, the office shall notify the submitting agency of any deficiency identified. If no notice of deficiency is mailed to the adopting agency within that time, a rulemaking file shall be deemed submitted as of the date of its original receipt by the office. A rulemaking file shall not be deemed submitted until each deficiency identified under this subdivision has been corrected.

(g) Notwithstanding any other law, return of the regulation to the adopting agency by the office pursuant to this section is the exclusive remedy for a failure to comply with subdivision (c) of Section 11346.3 or paragraph (10) of subdivision (a) of Section 11346.5.

Added Stats 1979 ch 567 § 1, operative July 1, 1980. Amended Stats 1979 ch 1152 § 12.8, operative July 1, 1980; Stats 1981 ch 865 § 32; Stats 1982 ch 86 § 5, effective March 1, 1982, ch 327 § 36, effective June 30, 1982, ch 1544 § 1, ch 1573 § 5; Stats 1985 ch 1044 § 4; Stats 1987 ch 1375 § 17.5; Stats 1991 ch 794 § 4 (AB 2061); Stats 1994 ch 1039 § 40 (AB 2531); Stats 2000 ch 1060 § 32 (AB 1822); Stats 2011 ch 496 § 9 (SB 617), effective January 1, 2012.

#### **§ 11349.1.5. Review of standardized regulatory impact analyses; Report; Notice of noncompliance.**

(a) The Department of Finance and the office shall, from time to time, review the standardized regulatory impact analyses required by subdivision (c) of Section 11346.3 and submitted to the office pursuant to Section 11347.3, for adherence to the regulations adopted by the department pursuant to Section 11346.36.

(b) On or before November 1, 2015, the office shall submit to the Senate and Assembly Committees on Governmental Organization a report describing the extent to which submitted standardized regulatory impact

analyses for proposed major regulations adhere to the regulations adopted pursuant to Section 11346.36. The report shall include a discussion of agency adherence to the regulations as well as a comparison between various state agencies on the question of adherence. The report may also include any recommendations from the office for actions the Legislature might consider for improving state agency performance.

(c) In addition to the report required by subdivision (b), the office may notify the Legislature of noncompliance by a state agency with the regulations adopted pursuant to Section 11346.36, in any manner or form determined by the office.

Added Stats 2011 ch 496 § 10 (SB 617), effective January 1, 2012.

#### **§ 11349.2. Adding material to file**

An agency may add material to a rulemaking file that has been submitted to the office for review pursuant to this article if addition of the material does not violate other requirements of this chapter.

Added Stats 2000 ch 1060 § 33 (AB 1822).

#### **§ 11349.3. Time for review of regulations; Procedure on disapproval; Return of regulations**

(a) The office shall either approve a regulation submitted to it for review and transmit it to the Secretary of State for filing or disapprove it within 30 working days after the regulation has been submitted to the office for review. If the office fails to act within 30 days, the regulation shall be deemed to have been approved and the office shall transmit it to the Secretary of State for filing.

(b) If the office disapproves a regulation, it shall return it to the adopting agency within the 30-day period specified in subdivision (a) accompanied by a notice specifying the reasons for disapproval. Within seven calendar days of the issuance of the notice, the office shall provide the adopting agency with a written decision detailing the reasons for disapproval. No regulation shall be disapproved except for failure to comply with the standards set forth in Section 11349.1 or for failure to comply with this chapter.

(c) If an agency determines, on its own initiative, that a regulation submitted pursuant to subdivision (a) should be returned by the office prior to completion of the office's review, it may request the return of the regulation. All requests for the return of a regulation shall be memorialized in writing by the submitting agency no later than one week following the request. Any regulation returned pursuant to this subdivision shall be resubmitted to the office for review within the one-year period specified in subdivision (b) of Section 11346.4 or shall comply with Article 5 (commencing with Section 11346) prior to resubmission.

(d) The office shall not initiate the return of a regulation pursuant to subdivision (c) as an alternative to disapproval pursuant to subdivision (b).

Added Stats 1979 ch 567 § 1, operative July 1, 1980. Amended Stats 1981 ch 865 § 33; Stats 1982 ch 1236 § 1; Stats 1985 ch 1044 § 5; Stats 1987 ch 1375 § 19; Stats 1991 ch 794 § 5 (AB 2061); Stats 1992 ch 1306 § 2 (AB 3511).

#### **§ 11349.4. Rewriting and resubmission of regulation; Review**

(a) A regulation returned to an agency because of failure to meet the standards of Section 11349.1, because

of an agency's failure to comply with this chapter may be rewritten and resubmitted within 120 days of the agency's receipt of the written opinion required by subdivision (b) of Section 11349.3 without complying with the notice and public hearing requirements of Sections 11346.4, 11346.5, and 11346.8 unless the substantive provisions of the regulation have been significantly changed. If the regulation has been significantly changed or was not submitted within 120 days of receipt of the written opinion, the agency shall comply with Article 5 (commencing with Section 11346) and readopt the regulation. The director of the office may, upon a showing of good cause, grant an extension to the 120-day time period specified in this subdivision.

(b) Upon resubmission of a disapproved regulation to the office pursuant to subdivision (a), the office shall only review the resubmitted regulation for those reasons expressly identified in the written opinion required by subdivision (b) of Section 11349.3, or for those issues arising as a result of a substantial change to a provision of the resubmitted regulation or as a result of intervening statutory changes or intervening court orders or decisions.

(c) When an agency resubmits a withdrawn or disapproved regulation to the office it shall identify the prior withdrawn or disapproved regulation by date of submission to the office, shall specify the portion of the prior rulemaking record that should be included in the resubmission, and shall submit to the office a copy of the prior rulemaking record if that record has been returned to the agency by the office.

(d) The office shall expedite the review of a regulation submitted without significant substantive change.

Added Stats 1979 ch 567 § 1, operative July 1, 1980. Amended Stats 1981 ch 865 § 34; Stats 1982 ch 1573 § 7; Stats 1983 ch 142 § 37; Stats 1985 ch 1044 § 6; Stats 1987 ch 1375 § 20.

### § 11349.5. Governor's review of decisions

(a) To initiate a review of a decision by the office, the agency shall file a written Request for Review with the Governor's Legal Affairs Secretary within 10 days of receipt of the written opinion provided by the office pursuant to subdivision (b) of Section 11349.3. The Request for Review shall include a complete statement as to why the agency believes the decision is incorrect and should be overruled. Along with the Request for Review, the agency shall submit all of the following:

(1) The office's written decision detailing the reasons for disapproval required by subdivision (b) of Section 11349.3.

(2) Copies of all regulations, notices, statements, and other documents which were submitted to the office.

(b) A copy of the agency's Request for Review shall be delivered to the office on the same day it is delivered to the Governor's office. The office shall file its written response to the agency's request with the Governor's Legal Affairs Secretary within 10 days and deliver a copy of its response to the agency on the same day it is delivered to the Governor's office.

(c) The Governor's office shall provide the requesting agency and the office with a written decision within 15 days of receipt of the response by the office to the agency's Request for Review. Upon receipt of the decision, the office shall publish in the California Regulatory

Notice Register the agency's Request for Review, the office's response thereto, and the decision of the Governor's office.

(d) The time requirements set by subdivisions (a) and (b) may be shortened by the Governor's office for good cause.

(e) The Governor may overrule the decision of the office disapproving a proposed regulation, an order repealing an emergency regulation adopted pursuant to subdivision (b) of Section 11346.1, or a decision refusing to allow the readoption of an emergency regulation pursuant to Section 11346.1. In that event, the office shall immediately transmit the regulation to the Secretary of State for filing.

(f) Upon overruling the decision of the office, the Governor shall immediately transmit to the Committees on Rules of both houses of the Legislature a statement of his or her reasons for overruling the decision of the office, along with copies of the adopting agency's initial statement of reasons issued pursuant to Section 11346.2 and the office's statement regarding the disapproval of a regulation issued pursuant to subdivision (b) of Section 11349.3. The Governor's action and the reasons therefor shall be published in the California Regulatory Notice Register.

Added Stats 1979 ch 567 § 1, operative July 1, 1980. Amended Stats 1980 ch 1238 § 5, effective September 29, 1980; Stats 1981 ch 865 § 34.5; Stats 1982 ch 86 § 6, effective March 1, 1982, ch 1236 § 2; Stats 1983 ch 724 § 1; Stats 1985 ch 1044 § 7; Stats 1987 ch 1375 § 20.2; Stats 1994 ch 1039 § 41 (AB 2531); Stats 1995 ch 938 § 15.6 (SB 523), operative January 1, 1996.

### § 11349.6. Review by office of emergency regulation

(a) If the adopting agency has complied with Sections 11346.2 to 11347.3, inclusive, prior to the adoption of the regulation as an emergency, the office shall approve or disapprove the regulation in accordance with this article.

(b) Emergency regulations adopted pursuant to subdivision (b) of Section 11346.1 shall be reviewed by the office within 10 calendar days after their submittal to the office. After posting a notice of the filing of a proposed emergency regulation on its Internet Web site, the office shall allow interested persons five calendar days to submit comments on the proposed emergency regulations unless the emergency situation clearly poses such an immediate serious harm that delaying action to allow public comment would be inconsistent with the public interest. The office shall disapprove the emergency regulations if it determines that the situation addressed by the regulations is not an emergency, or if it determines that the regulation fails to meet the standards set forth in Section 11349.1, or if it determines the agency failed to comply with Section 11346.1.

(c) If the office considers any information not submitted to it by the rulemaking agency when determining whether to file emergency regulations, the office shall provide the rulemaking agency with an opportunity to rebut or comment upon that information.

(d) Within 30 working days of the filing of a certificate of compliance, the office shall review the regulation and hearing record and approve or order the repeal of an emergency regulation if it determines that the regulation fails to meet the standards set forth in Section

11349.1, or if it determines that the agency failed to comply with this chapter.

Added Stats 1979 ch 567 § 1, operative July 1, 1980. Amended Stats 1979 ch 1203 § 9; Stats 1980 ch 1238 § 6, effective September 29, 1980; Stats 1981 ch 865 § 35; Stats 1982 ch 1236 § 3, ch 1573 § 8; Stats 1983 ch 797 § 23; Stats 1985 ch 1044 § 8; Stats 1987 ch 1375 § 20.5; Stats 1994 ch 1039 § 42 (AB 2531); Stats 2000 ch 1060 § 34 (AB 1822); Stats 2006 ch 713 § 4 (AB 1302), effective January 1, 2007.

## ARTICLE 7

### Review of Existing Regulations

Section

11349.7. Priority review of regulations

11349.8. Repeal of regulation for which statutory authority is repealed, ineffective or inoperative

11349.9. Review of notice of repeal

#### § 11349.7. Priority review of regulations

The office, at the request of any standing, select, or joint committee of the Legislature, shall initiate a priority review of any regulation, group of regulations, or series of regulations that the committee believes does not meet the standards set forth in Section 11349.1.

The office shall notify interested persons and shall publish notice in the California Regulatory Notice Register that a priority review has been requested, shall consider the written comments submitted by interested persons, the information contained in the rulemaking record, if any, and shall complete each priority review made pursuant to this section within 90 calendar days of the receipt of the committee's written request. During the period of any priority review made pursuant to this section, all information available to the office relating to the priority review shall be made available to the public. In the event that the office determines that a regulation does not meet the standards set forth in Section 11349.1, it shall order the adopting agency to show cause why the regulation should not be repealed and shall proceed to seek repeal of the regulation as provided by this section in accordance with the following:

(a) In the event it determines that any of the regulations subject to the review do not meet the standards set forth in Section 11349.1, the office shall within 15 days of the determination order the adopting agency to show cause why the regulation should not be repealed. In issuing the order, the office shall specify in writing the reasons for its determination that the regulation does not meet the standards set forth in Section 11349.1. The reasons for its determination shall be made available to the public. The office shall also publish its order and the reasons therefor in the California Regulatory Notice Register. In the case of a regulation for which no, or inadequate, information relating to its necessity can be furnished by the adopting agency, the order shall specify the information which the office requires to make its determination.

(b) No later than 60 days following receipt of an order to show cause why a regulation should not be repealed, the agency shall respond in writing to the office. Upon written application by the agency, the office may extend the time for an additional 30 days.

(c) The office shall review and consider all information submitted by the agency in a timely response to the order to show cause why the regulation should not be repealed,

and determine whether the regulation meets the standards set forth in Section 11349.1. The office shall make this determination within 60 days of receipt of an agency's response to the order to show cause. If the office does not make a determination within 60 days of receipt of an agency's response to the order to show cause, the regulation shall be deemed to meet the standards set forth in subdivision (a) of Section 11349.1. In making this determination, the office shall also review any written comments submitted to it by the public within 30 days of the publication of the order to show cause in the California Regulatory Notice Register. During the period of review and consideration, the information available to the office relating to each regulation for which the office has issued an order to show cause shall be made available to the public. The office shall notify the adopting agency within two working days of the receipt of information submitted by the public regarding a regulation for which an order to show cause has been issued. If the office determines that a regulation fails to meet the standards, it shall prepare a statement specifying the reasons for its determination. The statement shall be delivered to the adopting agency, the Legislature, and the Governor and shall be made available to the public and the courts. Thirty days after delivery of the statement required by this subdivision the office shall prepare an order of repeal of the regulation and shall transmit it to the Secretary of State for filing.

(d) The Governor, within 30 days after the office has delivered the statement specifying the reasons for its decision to repeal, as required by subdivision (c), may overrule the decision of the office ordering the repeal of a regulation. The regulation shall then remain in full force and effect. Notice of the Governor's action and the reasons therefor shall be published in the California Regulatory Notice Register.

The Governor shall transmit to the rules committee of each house of the Legislature a statement of reasons for overruling the decision of the office, plus any other information that may be requested by either of the rules committees.

(e) In the event that the office orders the repeal of a regulation, it shall publish the order and the reasons therefor in the California Regulatory Notice Register.

Added Stats 1994 ch 1039 § 43 (AB 2531).

#### § 11349.8. Repeal of regulation for which statutory authority is repealed, ineffective or inoperative

(a) If the office is notified of, or on its own becomes aware of, an existing regulation in the California Code of Regulations for which the statutory authority has been repealed or becomes ineffective or inoperative by its own terms, the office shall order the adopting agency to show cause why the regulation should not be repealed for lack of statutory authority and shall notify the Legislature in writing of this order. In issuing the order, the office shall specify in writing the reasons for issuance of the order. "Agency," for purposes of this section and Section 11349.9, refers to the agency that adopted the regulation and, if applicable, the agency that is responsible for administering the regulation in issue.

(b) The agency may, within 30 days after receipt of the written notification, submit in writing to the office any

citations, legal arguments, or other information opposing the repeal, including public comments during this period. This section shall not apply where the agency demonstrates in its response that any of the following conditions exists:

(1) The statute or section thereof is simultaneously repealed and substantially reenacted through a single piece of legislation, or where subsequent legislation evinces a specific legislative intent to reenact the substance of the statute or section. When a regulation cites more than one specific statute or section as reference or authority for the adoption of a regulation, and one or more of the statutes or sections are repealed or become ineffective or inoperative, then the only provisions of the regulation which remain in effect shall be those for which the remaining statutes or sections provide specific or general authority.

(2) The statute is temporarily repealed, or rendered ineffective or inoperative by a provision of law which is effective only for a limited period, in which case any regulation described in subdivision (a) is thereby also temporarily repealed, rendered ineffective, or inoperative during that limited period. Any regulation so affected shall have the same force and effect upon the expiration of the limited period during which the provision of law was effective as if that temporary provision had not been enacted.

(3) The statute or section of a statute being repealed, or becoming ineffective or inoperative by its own terms, is to remain in full force and effect as regards events occurring prior to the date of repeal or ineffectiveness, in which case any regulation adopted to implement or interpret that statute shall likewise be deemed to remain in full force and effect in regards to those same events.

(c) This section shall not be construed to deprive any person or public agency of any substantial right which would have existed prior to, or hereafter exists subsequent to, the effective date of this section.

(d) Thirty days after receipt of the agency's opposition material, or the close of the 30-day agency and public response period if no response is submitted, the office shall do one of the following:

(1) Inform the agency and the Legislature in writing that the office has withdrawn its order to show cause.

(2) Issue a written notice to the agency specifying the reasons for the repeal and its intent to file a Notice of Repeal of the invalid regulation with the Secretary of State. Within seven calendar days of the filing of the Notice of Repeal, the office shall provide the agency, the Governor, and the Legislature with a written decision detailing the reasons for the repeal and a copy of the Notice of Repeal, and publish the office's written decision in the California Regulatory Notice Register.

(e) The office shall order the removal of the repealed regulation from the California Code of Regulations within 30 days after filing the Notice of Repeal, if the agency has not appealed the office's decision, or upon receipt of notification of the Governor's decision upholding the office's decision, if an appeal has been filed pursuant to Section 11349.9.

Added Stats 1989 ch 1170 § 1, as Gov C § 11349.10. Amended and renumbered by Stats 1994 ch 1039 § 44 (AB 2531).

**§ 11349.9. Review of notice of repeal**

(a) To initiate a review of the office's Notice of Repeal pursuant to Section 11349.8, the agency shall appeal the office's decision by filing a written Request for Review with the Governor's Legal Affairs Secretary within 10 days of receipt of the Notice of Repeal and written decision provided for by paragraph (2) of subdivision (d) of Section 11349.8. The Request for Review shall include a complete statement as to why the agency believes the decision is incorrect and should be overruled. Along with the Request for Review, the agency shall submit all of the following:

(1) The office's written opinion detailing the reasons for repeal required by paragraph (2) of subdivision (d) of Section 11349.8.

(2) Copies of all statements and other documents that were submitted to the office.

(b) A copy of the agency's Request for Review shall be delivered to the office on the same day it is delivered to the Governor's office. The office shall file its written response to the agency's request with the Governor's Legal Affairs Secretary within 10 days, and deliver a copy of its response to the agency on the same day it is delivered to the Governor's office.

(c) The Governor's office shall provide the requesting agency and the office with a written decision within 15 days of receipt of the response by the office to the agency's Request for Review. Upon receipt of the decision, the office shall publish in the California Regulatory Notice Register the agency's Request for Review, the office's response thereto, and the decision of the Governor's office.

(d) The time requirements set by subdivisions (a) and (b) may be shortened by the Governor's office for good cause.

(e) In the event the Governor overrules the decision of the office, the office shall immediately transmit the regulation to the Secretary of State for filing.

(f) Upon overruling the decision of the office, the Governor shall transmit to the rules committees of both houses of the Legislature a statement of the reasons for overruling the decision of the office.

Added Stats 1989 ch 1170 § 2 as Gov C § 11349.11. Amended and renumbered by Stats 1994 ch 1039 § 45 (AB 2531). Amended Stats 1995 ch 938 § 15.7 (SB 523), operative January 1, 1996.

**ARTICLE 8**

**Judicial Review**

Section

11350. Judicial declaration regarding validity of regulation; Grounds for invalidity

11350.3. Judicial declaration as to validity of disapproved or repealed regulation

**§ 11350. Judicial declaration regarding validity of regulation; Grounds for invalidity**

(a) Any interested person may obtain a judicial declaration as to the validity of any regulation or order of repeal by bringing an action for declaratory relief in the superior court in accordance with the Code of Civil Procedure. The right to judicial determination shall not be affected by the failure either to petition or to seek reconsideration of a petition filed pursuant to Section

11340.7 before the agency promulgating the regulation or order of repeal. The regulation or order of repeal may be declared to be invalid for a substantial failure to comply with this chapter, or, in the case of an emergency regulation or order of repeal, upon the ground that the facts recited in the finding of emergency prepared pursuant to subdivision (b) of Section 11346.1 do not constitute an emergency within the provisions of Section 11346.1.

(b) In addition to any other ground that may exist, a regulation or order of repeal may be declared invalid if either of the following exists:

(1) The agency's determination that the regulation is reasonably necessary to effectuate the purpose of the statute, court decision, or other provision of law that is being implemented, interpreted, or made specific by the regulation is not supported by substantial evidence.

(2) The agency declaration pursuant to paragraph (8) of subdivision (a) of Section 11346.5 is in conflict with substantial evidence in the record.

(c) The approval of a regulation or order of repeal by the office or the Governor's overruling of a decision of the office disapproving a regulation or order of repeal shall not be considered by a court in any action for declaratory relief brought with respect to a regulation or order of repeal.

(d) In a proceeding under this section, a court may only consider the following evidence:

(1) The rulemaking file prepared under Section 11347.3.

(2) The finding of emergency prepared pursuant to subdivision (b) of Section 11346.1.

(3) An item that is required to be included in the rulemaking file but is not included in the rulemaking file, for the sole purpose of proving its omission.

(4) Any evidence relevant to whether a regulation used by an agency is required to be adopted under this chapter.

Added Stats 1979 ch 567 § 1, operative July 1, 1980. Amended Stats 1981 ch 592 § 1, ch 865 § 37; Stats 1982 ch 86 § 9, effective March 1, 1982, ch 1573 § 10; Stats 1991 ch 794 § 6 (AB 2061); Stats 1994 ch 1039 § 47 (AB 2531); Stats 1995 ch 938 § 15.8 (SB 523), operative January 1, 1996; Stats 2000 ch 1060 § 35 (AB 1822); Stats 2006 ch 713 § 5 (AB 1302), effective January 1, 2007.

### § 11350.3. Judicial declaration as to validity of disapproved or repealed regulation

Any interested person may obtain a judicial declaration as to the validity of a regulation or order of repeal which the office has disapproved pursuant to Section 11349.3, or 11349.6, or of a regulation that has been ordered repealed pursuant to Section 11349.7 by bringing an action for declaratory relief in the superior court in accordance with the Code of Civil Procedure. The court may declare the regulation valid if it determines that the regulation meets the standards set forth in Section 11349.1 and that the agency has complied with this chapter. If the court so determines, it may order the office to immediately file the regulation with the Secretary of State.

Added Stats 1982 ch 1544 § 2, ch 1573 § 11. Amended Stats 1987 ch 1375 § 23.5; Stats 1994 ch 1039 § 48 (AB 2531); Stats 2000 ch 1060 § 36 (AB 1822).

## PART 2 Constitutional Officers

### CHAPTER 6 Attorney General

#### ARTICLE 10 Securities and Commodities

##### Section

##### 12657. Definitions

12658. Action by Attorney General to enjoin acts or enforce compliance with securities or commodities law; Injunction; Appointment of designated fiduciary; Claim for ancillary relief; Judgment for restitution

12659. Investigations by Attorney General; Publication of information; Refusal to obey subpoena; Exemption from prosecution

12660. Civil penalties for violation of securities or commodities law; Nonexclusive remedies; Time limitation for actions

12661. Powers of Attorney General to take actions under federal Commodity Exchange Act or other laws

#### § 12657. Definitions

For purposes of this article, the following terms shall have the following meanings:

(a) "Securities law" shall mean the Corporate Securities Law of 1968 (Division 1 (commencing with Section 25000) of Title 4 of the Corporations Code) and any other rule or order issued by the Commissioner of Corporations under this law.

(b) "Commodities law" shall mean the California Commodity Law of 1990 (Division 4.5 (commencing with Section 29500) of Title 4 of the Corporations Code) and any other rule or order issued by the Commissioner of Corporations under this law.

Added Stats 2003 ch 876 § 13 (SB 434).

#### § 12658. Action by Attorney General to enjoin acts or enforce compliance with securities or commodities law; Injunction; Appointment of designated fiduciary; Claim for ancillary relief; Judgment for restitution

(a) Whenever it appears to the Attorney General that any person has engaged or is about to engage in any act or practice constituting a violation of the securities law or the commodities law, the Attorney General may, in his or her discretion, bring an action in the name of the people of the State of California in the superior court to enjoin the acts or practices or to enforce compliance with the securities law or the commodities law. Upon a proper showing, a permanent or preliminary injunction, restraining order, or writ of mandate shall be granted and a receiver, monitor, conservator, or other designated fiduciary or officer of the court may be appointed for the defendant or the defendant's assets, or any other ancillary relief may be granted as appropriate. A receiver, monitor, conservator, or other designated fiduciary or officer of the court appointed by the superior court pursuant to this section may, with the approval of the court, exercise any or all of the powers of the defendant's officers, directors, partners, trustees or persons who exercise similar powers and perform similar duties,

including the filing of a petition for bankruptcy. No action at law or in equity may be maintained by any party against the Attorney General, or a receiver, monitor, conservator, or other designated fiduciary or officer of the court, by reason of their exercising these powers or performing these duties pursuant to the order of, or with the approval of, the superior court.

(b) If the Attorney General determines it is in the public interest, the Attorney General may include in any action authorized by subdivision (a) a claim for ancillary relief, including, but not limited to, a claim for restitution or disgorgement or damages on behalf of the persons injured by the act or practice constituting the subject matter of the action, and the court shall have jurisdiction to award additional relief.

(c) In any case in which a defendant is ordered by the court to pay restitution to a victim, the court may in its order require the payment as a money judgment, which shall be enforceable by a victim as if the restitution order were a separate civil judgment, and enforceable in the same manner as is provided for the enforcement of any other money judgment. Any order issued under this subdivision shall contain provisions that are designed to achieve a fair and orderly satisfaction of the judgment.

Added Stats 2003 ch 876 § 13 (SB 434).

**§ 12659. Investigations by Attorney General; Publication of information; Refusal to obey subpoena; Exemption from prosecution**

(a) The Attorney General, in his or her discretion, (1) may make public or private investigations within or outside of this state that the Attorney General deems necessary to determine whether any person has violated or is about to violate the securities law or the commodities law or to aid in the enforcement of these laws or in the prescribing of rules and forms by the Commissioner of Corporations under these laws, and (2) may publish information concerning any violation of the securities law or the commodities law.

(b) In making any investigation authorized by subdivision (a), the Attorney General may, for a reasonable time not exceeding 30 days, take possession of the books, records, accounts, and other papers pertaining to the business of any broker-dealer or investment adviser and place a keeper in exclusive charge of them in the place where they are usually kept. During this possession no person shall remove or attempt to remove any of the books, records, accounts, or other papers except pursuant to a court order or with the consent of the Attorney General, but the directors, officers, partners, and employees of the broker-dealer or investment adviser may examine them, and employees shall be permitted to make entries therein reflecting current transactions.

(c) For the purpose of any investigation or proceeding under the securities law or the commodities law, the Attorney General or any officer designated by him or her may administer oaths and affirmations, subpoena witnesses, compel their attendance, take evidence, and require the production of books, papers, correspondence, memoranda, agreements, or other documents or records that the Attorney General deems relevant or material to the inquiry.

(d) In case of contumacy by, or refusal to obey a subpoena issued to, any person, the superior court, upon application by the Attorney General, may issue to the person an order requiring him or her to appear before the Attorney General, or the officer designated by the Attorney General, there to produce documentary evidence, if so ordered, or to give evidence touching the matter under investigation or in question. Failure to obey the order of the court may be punished by the court as a contempt.

(e) No person is excused from attending and testifying or from producing any document or record before the Attorney General, or in obedience to the subpoena of the Attorney General or any officer designated by him or her, or in any proceeding instituted by the Attorney General, on the ground that the testimony or evidence, documentary or otherwise, required of him or her may tend to incriminate him or her or subject him or her to a penalty or forfeiture, but no individual may be prosecuted or subjected to any penalty or forfeiture for or on account of any transaction, matter, or thing concerning which he or she is compelled, after validly claiming his or her privilege against self-incrimination, to testify or produce evidence, documentary or otherwise, except that an individual testifying is not exempt from prosecution and punishment for perjury or contempt committed in testifying.

Added Stats 2003 ch 876 § 13 (SB 434).

**§ 12660. Civil penalties for violation of securities or commodities law; Nonexclusive remedies; Time limitation for actions**

(a) Any person who violates any provision of the securities law or the commodities law shall be liable for a civil penalty not to exceed twenty-five thousand dollars (\$25,000) for each violation, which shall be assessed and recovered in a civil action brought in the name of the people of the State of California by the Attorney General in any court of competent jurisdiction.

(b) As applied to the penalties for acts in violation of the securities law or the commodities law, the remedies provided by this section and by other sections of this article are not exclusive, and may be sought and employed in any combination to enforce the provisions of this article.

(c) No action shall be maintained to enforce any liability created under subdivision (a) unless brought before the expiration of four years after the act or transaction constituting the violation.

Added Stats 2003 ch 876 § 13 (SB 434).

**§ 12661. Powers of Attorney General to take actions under federal Commodity Exchange Act or other laws**

(a) The Attorney General may take any actions as are authorized by Section 6d of the federal Commodity Exchange Act (7 U.S.C. Sec. 1 et seq.) as amended before or after the effective date of this section.

(b) Nothing in this article shall be construed as a limitation on the powers of the Attorney General under this division or any other law administered by the Attorney General.

Added Stats 2003 ch 876 § 13 (SB 434).



# HEALTH AND SAFETY CODE

## DIVISION 20

### Miscellaneous Health and Safety Provisions

#### CHAPTER 6.5

#### Hazardous Waste Control

#### ARTICLE 13.5

#### Motor Vehicle Brake Friction Materials

Section

- 25250.50. Definitions  
25250.51. Proscription against sale of brake friction materials containing enumerated constituents  
25250.52. Sale of brake friction material exceeding 5 percent copper by weight  
25250.53. Sale of brake friction material exceeding 0.5 percent copper by weight  
25250.54. Extension of deadline  
25250.55. Exemption from article  
25250.60. Testing and marking brake friction materials; Compliance; Certification  
25250.62. Violation; Civil fine; Replacement  
25250.64. Brake Friction Materials Water Pollution Fund established; Expenditure to implement article  
25250.65. (Repealed January 1, 2027) Report and recommendations on implementation of vehicle brake copper reduction efforts

#### § 25250.50. Definitions

For purposes of this article, the following definitions shall apply:

(a)(1) “Advisory committee” means a committee of nine members appointed by the secretary on or before January 1, 2019, to consider and recommend approval or denial of an application for an extension of the requirements imposed pursuant to Section 25250.53.

(2) A person considered for appointment to the advisory committee shall disclose any financial interests the person may have in any aspect of the vehicle or vehicle parts manufacturing industry prior to appointment by the secretary or, in the case of subparagraph (C) of paragraph (3), prior to nomination.

(3) The advisory committee shall be composed of the following members:

(A)(i) One-third of the members shall be representatives of the manufacturers of brake friction materials and motor vehicles, to be appointed by the secretary in consultation with the chair of the board and the director of the department.

(ii) If the application for an extension of the requirements imposed pursuant to Section 25250.53 pertains solely to brake friction materials to be used on heavy-duty motor vehicles, the members appointed pursuant to this subparagraph shall represent the manufacturers of heavy-duty brake friction materials and heavy-duty motor vehicles.

(B) One-third of the members shall be representatives of municipal storm water quality agencies and nongov-

ernmental environmental organizations, to be appointed by the secretary in consultation with the chair of the board and the director of the department.

(C) One-third of the members shall be experts in vehicle and braking safety, economics, and other relevant technical areas, to be appointed by the secretary, upon nomination by a majority of the members specified in subparagraph (A) concurrently with a majority of the members specified in subparagraph (B).

(4) For purposes of this subdivision, a “financial interest” shall have the same meaning as a financial interest described in Section 87103 of the Government Code, except only with regard to business entities, real property, or sources of income that are related to the vehicle or vehicle parts manufacturing industry.

(b) “Board” means the State Water Resources Control Board.

(c) “Department” means the Department of Toxic Substances Control.

(d) “Heavy-duty motor vehicle” means a motor vehicle of over 26,000 pounds gross weight.

(e)(1) “Manufacturer,” except where otherwise specified, means both of the following:

(A) A manufacturer or assembler of motor vehicles or motor vehicle equipment.

(B) An importer of motor vehicles or motor vehicle equipment for resale.

(2) A manufacturer includes a vehicle brake friction materials manufacturer.

(f) “Motor vehicle” and “vehicle” have the same meaning as the definition of “vehicle” in Section 670 of the Vehicle Code.

(g) “Testing certification agency” means a third-party testing certification agency that is utilized by a vehicle brake friction materials manufacturer and that has an accredited laboratory program that provides testing in accordance with the certification agency requirements that are approved by the department.

Added Stats 2010 ch 307 § 2 (SB 346), effective January 1, 2011.  
Amended Stats 2011 ch 296 § 156 (AB 1023), effective January 1, 2012.  
Amended Stats 2011 ch 296 § 156 (AB 1023), effective January 1, 2012.

#### § 25250.51. Proscription against sale of brake friction materials containing enumerated constituents

(a) On and after January 1, 2014, any motor vehicle brake friction materials containing any of the following constituents in an amount that exceeds the following concentrations shall not be sold in this state:

(1) Cadmium and its compounds: 0.01 percent by weight.

(2) Chromium (VI)-salts: 0.1 percent by weight.

(3) Lead and its compounds: 0.1 percent by weight.

(4) Mercury and its compounds: 0.1 percent by weight.

(5) Asbestiform fibers: 0.1 percent by weight.

(b) Motor vehicle manufacturers and distributors, wholesalers, or retailers of replacement brake friction materials may continue to sell or offer for sale brake friction materials not certified as compliant with subdivision (a) solely for the purpose of depletion of inventories until December 31, 2023.

(c) Notwithstanding subdivision (b), motor vehicle dealers may continue to sell or offer for sale brake friction material not certified as compliant with subdivision (a) if the brake friction material was installed on a vehicle before the vehicle was acquired by the dealer.

Added Stats 2010 ch 307 § 2 (SB 346), effective January 1, 2011.  
Amended Stats 2013 ch 392 § 1 (AB 501), effective January 1, 2014.

**§ 25250.52. Sale of brake friction material exceeding 5 percent copper by weight**

On and after January 1, 2021, any motor vehicle brake friction materials exceeding 5 percent copper by weight shall not be sold in this state, except as otherwise provided in this article.

Added Stats 2010 ch 307 § 2 (SB 346), effective January 1, 2011.

**§ 25250.53. Sale of brake friction material exceeding 0.5 percent copper by weight**

On and after January 1, 2025, any motor vehicle brake friction materials exceeding 0.5 percent copper by weight shall not be sold in this state, except as otherwise provided in this article.

Added Stats 2010 ch 307 § 2 (SB 346), effective January 1, 2011.

**§ 25250.54. Extension of deadline**

(a)(1) On and after January 1, 2019, a manufacturer may apply to the department for a one-year, two-year, or three-year extension of the January 1, 2025, deadline established in Section 25250.53, except as provided in subdivision (h).

(2) An extension application submitted pursuant to this section shall be submitted based on vehicle model, class, platform, or other vehicle-based category, and not on the basis of the brake friction material formulation.

(3) The application shall be accompanied by documentation that will allow the advisory committee to make a recommendation pursuant to subdivisions (e) and (f).

(4) The documentation shall include a scientifically sound quantitative estimate of the quantity of copper that would be emitted if the extension is granted, including a description of the assumptions used in arriving at that estimate.

(b) No more than 30 days after receipt of an application for an extension pursuant to subdivision (a), the department shall do all of the following:

(1) Post a notice of receipt on the department's Internet Web site that includes the vehicle model, class, platform, or other vehicle-based category, whether the brake friction material is intended for use in original equipment or replacement parts, and the quantity of copper that would be emitted if the extension is granted.

(2) Consult with the board and the State Air Resources Board.

(3) Solicit comment from the public and from scientific and vehicle engineering experts on the availability of generally affordable compliant brake friction materials,

their safety and performance characteristics, and the feasibility of brake pad copper emissions reduction through means other than friction material reformulation.

(c)(1) In consultation with the board, the department shall determine if sufficient documentation has been presented upon which to base a decision. If the department determines that further documentation is needed, it shall deliver a detailed request for further documentation to the applicant.

(2) Not later than 30 days after receipt of the application for an extension pursuant to subdivision (a), the department shall forward the application to the advisory committee for the purpose of the advisory committee making a recommendation pursuant to subdivisions (e) and (f).

(d)(1) In considering any application for an extension, the advisory committee shall consider all of the documentation supplied by the applicant pursuant to subdivision (a).

(2) The advisory committee may request, no later than 75 days after receipt of the application from the department pursuant to subdivision (c), further documentation from the applicant.

(3) The advisory committee shall hold at least one public hearing at which it shall accept and consider comments from the public on each category of application. The advisory committee meetings shall be open to the public and are subject to the Bagley-Keene Open Meeting Act (Article 9 (commencing with Section 11120) of Chapter 1 of Part 1 of Division 3 of Title 2 of the Government Code).

(e)(1) The advisory committee shall recommend to the secretary that the extension be approved if the advisory committee determines that there are no brake friction materials that are safe and available for individual or multiple vehicle models, classes, platforms, or other vehicle-based categories identified in the application.

(2) The advisory committee shall recommend to the secretary that the extension not be approved if the advisory committee determines that alternative brake friction materials are safe and available for individual or multiple vehicle models, classes, platforms, or other vehicle-based categories identified in the application.

(3) For purposes of this section, "safe and available" shall mean all of the following:

(A) The brake system for which the alternative brake friction material is manufactured meets applicable federal safety standards, or if no federal standard exists, a widely accepted safety standard.

(B) Acceptable alternative brake friction materials are commercially available for the individual or multiple vehicles, classes, platforms, or vehicle-based categories identified in the application.

(C) Adequate industry testing and production capacity exists to supply the alternative brake friction materials for use on the individual or multiple vehicles, classes, platforms, or vehicle-based categories identified in the application.

(D) The alternative brake friction material is technically feasible for use on the individual or multiple vehicles, classes, platforms, or vehicle-based categories identified in the application.

(E) The alternative brake friction materials meet customer performance expectations, including noise, wear, vibration, and durability for the individual or multiple vehicles, classes, platforms, or vehicle-based categories identified in the application.

(F) The alternative acceptable brake friction material is economically feasible with respect to the industry and the cost to the consumer for the individual or multiple vehicles, classes, platforms, or vehicle-based categories identified in the application.

(4) The advisory committee shall provide relevant data to the department and the board concerning the potential impacts of the extension on California watersheds for purposes of the report required pursuant to Section 25250.65.

(f)(1) No sooner than 60 days and no later than 120 days after the department solicits comments pursuant to paragraph (3) of subdivision (b), the advisory committee shall make a recommendation to the secretary in accordance with subdivisions (d) and (e) as to whether the application for extension should be approved or not approved.

(2) The recommendation of the advisory committee that the secretary approve or not approve the application for extension shall be accompanied by documentation of the basis for the recommendation.

(g)(1) The secretary shall make available the recommendation of the advisory committee and the accompanying documentation for public review and comment for 60 days following receipt of the recommendation from the advisory committee.

(2) The secretary shall consider public comments on the advisory committee's recommendation and issue a final decision on the application for extension no later than 45 days after the conclusion of the 60-day comment period.

(3) In making the determination whether to approve or disapprove the extension, the secretary shall rely upon the recommendations made by the advisory committee pursuant to subdivision (f).

(4) If the secretary does not follow the recommendation of the advisory committee made pursuant to subdivision (f), he or she shall explain in writing the basis of his or her decision.

(h)(1) On or before December 31, 2029, a manufacturer with an approved extension of the January 1, 2025, deadline established in Section 25250.53, may reapply to the department for additional two-year extensions from the deadline in accordance with a schedule that may be established by the department.

(2) Except as provided in subdivision (i), a manufacturer may not apply on or after January 1, 2030, for an extension of the January 1, 2025, deadline established in Section 25250.53.

(3) The department shall comply with all of the requirements of this section when granting an additional extension of the January 1, 2025, deadline pursuant to this subdivision.

(i)(1) On and after January 1, 2030, a manufacturer of vehicle brake friction materials to be used on heavy-duty vehicles with an approved extension of the January 1, 2025, deadline established in Section 25250.53, may reapply to the department for additional two-year extensions from the deadline established in Section 25250.53,

that results in an extension of that deadline to a date on and after January 1, 2032.

(2) The department shall comply with all of the requirements of this section when granting an additional extension of the January 1, 2025, deadline pursuant to this subdivision.

(j) The department shall assess a fee for each application for an extension sufficient to cover actual costs incurred in implementing this section. The department may expend the fees collected pursuant to this subdivision, upon appropriation by the Legislature, for reimbursement for the costs incurred in implementing this section.

(k) When granting an extension pursuant to this section, the department, board, advisory committee, and secretary shall comply with the requirements of Section 25358.2, to ensure the protection of trade secrets, as defined in Section 25358.2.

Added Stats 2010 ch 307 § 2 (SB 346), effective January 1, 2011.  
Amended Stats 2011 ch 296 § 157 (AB 1023), effective January 1, 2012.  
Amended Stats 2011 ch 296 § 157 (AB 1023), effective January 1, 2012.

#### § 25250.55. Exemption from article

Brake friction materials for the following motor vehicle classes are exempt from this article:

(a) Military tactical support vehicles.

(b) Vehicles employing internal closed oil immersed brakes, or a similar brake system that is fully contained and emits no copper, other debris, or fluids under normal operating conditions.

(c) Brakes designed for the primary purpose of holding the vehicle stationary and not designed to be used while the vehicle is in motion.

(d) Motorcycles.

(e) Motor vehicles subject to voluntary or mandatory recalls of brake friction materials or systems due to safety concerns. This exemption shall expire upon the lifting of the recall and provision of new brake friction materials that comply with this article.

(f) Motor vehicles manufactured by small volume manufacturers, as defined in Section 1900 of Title 13 of the California Code of Regulations.

(g) Vehicles manufactured prior to January 1, 2021, and brake friction materials for use on vehicles manufactured prior to January 1, 2021, from the requirements of Section 25250.52.

(h) Vehicles manufactured prior to January 1, 2025, and brake friction materials for use on vehicles manufactured prior to January 1, 2025, from the requirements of Section 25250.53.

(i) Vehicles for which an extension from the requirements of Section 25250.53 was approved pursuant to Section 25250.54.

Added Stats 2010 ch 307 § 2 (SB 346), effective January 1, 2011.

#### § 25250.60. Testing and marking brake friction materials; Compliance; Certification

(a) The department shall consult with the brake friction materials manufacturing industry in the development of all criteria for testing and marking brake friction materials and adopting certification procedures for brake friction materials, as required pursuant to this article. The mark of proof of certification on brake friction materials shall identify the brake friction mate-

rial manufacturer, be easily applied, be easily legible, and not impose unreasonable additional costs on manufacturers due to the use of additional equipment or other factors.

(b) On and after January 1, 2014, any new motor vehicle offered for sale in the state shall be equipped with brake friction materials that comply with of Section 25250.51.

(c)(1) On and after January 1, 2014, a manufacturer of vehicle brake friction materials used in brakes on new motor vehicles or as replacement parts that are sold in the state shall certify compliance declaring that its formulation for brake friction materials complies with Section 25250.51.

(2) A vehicle brake friction material manufacturer shall mark proof of certification pursuant to this subdivision on all brake friction materials.

(d) On and after January 1, 2021, any new motor vehicle offered for sale in the state shall be equipped with brake friction materials that comply with Section 25250.52.

(e)(1) On and after January 1, 2021, a manufacturer of vehicle brake friction materials used in brakes on new motor vehicles or as replacement parts for those vehicles that are sold in the state shall certify compliance declaring that its formulation for brake friction materials complies with Section 25250.52.

(2) A vehicle brake friction material manufacturer shall mark proof of certification with this subdivision on all brake friction materials.

(f) On and after January 1, 2025, any new motor vehicle offered for sale in the state shall be equipped with brake friction materials that comply with Section 25250.53.

(g)(1) On and after January 1, 2025, a manufacturer of vehicle brake friction materials used in brakes on new motor vehicles or as replacement parts for those vehicles that are sold in the state shall certify compliance declaring that its formulation for brake friction materials complies with Section 25250.53.

(2) A vehicle brake friction material manufacturer shall mark proof of certification with this subdivision on all brake friction materials.

(h) Prior to offering brake friction materials for sale in this state, a manufacturer of vehicle brake friction materials shall file a copy of the certification for each of its brake friction materials formulations with a testing certification agency. Each certification shall be made available within a reasonable period of time on the testing certification agency's Internet Web site at no cost to the department and to the public, and shall serve as official registration of certification for compliance with this section.

(i) A manufacturer of vehicle brake friction materials may obtain from a testing certification agency a certification of compliance with the requirements of Section 25250.51, 25250.52, or 25250.53 at any time prior to the dates specified in those sections.

(j) The certification and mark of proof required pursuant to this section shall show a consistent date format, designation, and labeling to facilitate acceptance in all 50 states and United States territories for purposes of demonstrating compliance with all applicable requirements.

Added Stats 2010 ch 307 § 2 (SB 346), effective January 1, 2011.

#### § 25250.62. Violation; Civil fine; Replacement

(a) A violation of this article by a vehicle manufacturer, a vehicle brake friction materials manufacturer, a distributor, or a retailer, shall be subject to a civil fine of up to ten thousand dollars (\$10,000) per violation.

(b) The department shall enforce this article. The department shall remove from sale in this state any replacement brake friction materials determined to be not in compliance with this article.

(c) If the department determines that a distributor, wholesaler, or retailer of replacement brake friction materials has been offering noncompliant brake friction materials for sale in the state, it shall allow the distributor, wholesaler, or retailer of replacement brake friction materials to establish that it obtained the noncompliant brake friction materials in good faith and after exercising due diligence in verifying that the material complied with this article prior to assessing fines and penalties pursuant to subdivision (a).

(d) In determining the amount of the civil fine to be assessed for a violation of this article, the department shall consider the particular circumstances of the violation, including, but not limited to, the amount of noncompliant brake friction material offered for sale in California and whether previous violations have occurred.

(e) The department may waive the imposition of a fine and issue a letter of warning if it determines, based on criteria, including, but not limited to, the amount of brake friction material offered for sale, the presence or absence of prior violations, and whether due diligence was exercised in determining that the brake friction materials offered for sale complied with this article, and that the violation of this article does not merit the imposition of a fine.

(f) A distributor, wholesaler, or retailer found by the department to have offered for sale noncompliant replacement brake materials shall cooperate with the department in the removal of the noncompliant brake friction materials from sale, inform the department of measures being implemented to avoid repeat violations, and provide the department with information that will assist in the identification and location of the source or sources of the noncompliant brake friction materials.

(g) In enforcing this article, the department shall not recall automobiles fitted with brake friction materials that do not comply with this article.

(h) A motor vehicle manufacturer that violates this article shall notify the registered owner of the vehicle within six months of knowledge of the violation and shall replace, at no cost to the owner, the noncompliant brake friction material with brake friction material that complies with this article. A motor vehicle manufacturer that fails to provide the required notification to registered owners of the affected vehicles within six months of knowledge of the violation is subject to fines and penalties authorized pursuant to subdivision (a).

Added Stats 2010 ch 307 § 2 (SB 346), effective January 1, 2011.

#### § 25250.64. Brake Friction Materials Water Pollution Fund established; Expenditure to implement article

(a) The Brake Friction Materials Water Pollution Fund is hereby established in the State Treasury. Not-

withstanding Section 25192, all fines and penalties collected by the department pursuant to this article shall be deposited in the fund.

(b) The moneys in the fund shall be expended, upon appropriation by the Legislature in the annual Budget Act, solely for the full implementation of this article by the department.

Added Stats 2010 ch 307 § 2 (SB 346), effective January 1, 2011.

**§ 25250.65. (Repealed January 1, 2027) Report and recommendations on implementation of vehicle brake copper reduction efforts**

(a) On or before January 1, 2023, the department and the board shall submit to the Governor and the Legislature, in compliance with Section 9795 of the Government Code, a report on the implementation of vehicle brake copper reduction efforts and the progress of this article

toward meeting the copper total maximum daily load (TMDL) allocations in the state. The report shall make recommendations on actions necessary to address any deficiencies in meeting these copper TMDL allocations, including, but not limited to:

(1) Imposing additional restrictions on the extensions granted to manufacturers pursuant to Section 25250.54.

(2) Imposing additional restrictions on the exemptions from this article provided by Section 25250.55.

(3) Allowances for permitting a manufacturer to sell existing inventory, if the additional restrictions described in paragraphs (1) and (2) are implemented.

(b) Pursuant to Section 10231.5 of the Government Code, this section is repealed on January 1, 2027.

Added Stats 2010 ch 307 § 2 (SB 346), effective January 1, 2011, repealed January 1, 2027.

## DIVISION 26

### Air Resources

#### PART 1

#### General Provisions and Definitions

#### CHAPTER 2

#### Definitions

Section

39010. Definitions governing construction

39011.5. "Agricultural source of air pollution" or "agricultural source"; Applicability of certain district rules or regulations; Authority of district to regulate a source

39012. "Air basin"

39013. "Air contaminant"; "Air pollutant"

39014. "Ambient air quality standards"

39016.5. "Bureau"

39018. "Certification"

39019. "Certified device"

39021. "Commercial vehicle"

39024.5. "Department"

39024.6. "Direct import vehicle"

39025. "District"

39027. "Emission standards"

39027.3. Definitions

39027.5. (Operative date contingent; Operative term contingent) "Emissions retrofit device"

39028. "Exhaust device"

39029. "Exhaust emissions"

39032.5. "Gross polluter"

39033. "Heavy-duty"

39035. "Light-duty"

39037.05. Low-emission motor vehicle

39037.5. "Medium duty"

39038. "Model year"

39039. "Motor vehicle"

39040. "Motor vehicle pollution control device"

39041. "Motorcycle"

39042. "New motor vehicle"

39042.5. "New motor vehicle engine"

39046. "Passenger vehicle"

39053. "State Board"

39058. "Used motor vehicle"

39059. "Vehicle"

39060. "Vehicular sources"

**§ 39010. Definitions governing construction**

Unless the context requires otherwise, a definition set forth in this chapter shall govern the construction of

this division, unless and until rules and regulations are adopted by the state board pursuant to Section 39601 which revise such definition.

Added Stats 1975 ch 957 § 12. Amended Stats 1976 ch 1063 § 3, effective September 21, 1976.

**§ 39011.5. "Agricultural source of air pollution" or "agricultural source"; Applicability of certain district rules or regulations; Authority of district to regulate a source**

(a) "Agricultural source of air pollution" or "agricultural source" means a source of air pollution or a group of sources used in the production of crops, or the raising of fowl or animals located on contiguous property under common ownership or control that meets any of the following criteria:

(1) Is a confined animal facility, including, but not limited to, any structure, building, installation, barn, corral, coop, feed storage area, milking parlor, or system for the collection, storage, treatment, and distribution of liquid and solid manure, if domesticated animals, including, but not limited to, cattle, calves, horses, sheep, goats, swine, rabbits, chickens, turkeys, or ducks are corralled, penned, or otherwise caused to remain in restricted areas for commercial agricultural purposes and feeding is by means other than grazing.

(2) Is an internal combustion engine used in the production of crops or the raising of fowl or animals, including, but not limited to, an engine subject to Article 1.5 (commencing with Section 41750) of Chapter 3 of Part 4 except an engine that is used to propel implements of husbandry, as that term is defined in Section 36000 of the Vehicle Code, as that section existed on January 1, 2003. Notwithstanding subdivision (b) of Section 39601, the state board may not revise this definition for the purposes of this section.

(3) Is a Title V source, as that term is defined in Section 39053.5, or is a source that is otherwise subject to regulation by a district pursuant to this division or the federal Clean Air Act (42 U.S.C. Sec. 7401 et seq.).

(b) Any district rule or regulation affecting stationary sources on agricultural operations adopted on or before January 1, 2004, is applicable to an agricultural source.

(c) Nothing in this section limits the authority of a district to regulate a source, including, but not limited to, a stationary source that is an agricultural source, over which it otherwise has jurisdiction pursuant to this division, or pursuant to the federal Clean Air Act (42 U.S.C. Sec. 7401 et seq.) or any rules or regulations adopted pursuant to that act that were in effect on or before January 1, 2003, or to exempt an agricultural source from any requirement otherwise applicable under Section 40724 or 42301.16, based upon a finding by the district in a public hearing that the aggregate emissions from that source do not exceed a de minimis level of more than one ton of particulate matter, nitrogen oxides, or volatile organic compounds per year.

Added Stats 2003 ch 479 § 2 (SB 700). Amended Stats 2004 ch 183 § 215 (AB 3082).

**§ 39012. “Air basin”**

“Air basin” means an area of the state designated by the state board pursuant to subdivision (a) of Section 39606.

Added Stats 1975 ch 957 § 12.

**§ 39013. “Air contaminant”; “Air pollutant”**

“Air contaminant” or “air pollutant” means any discharge, release, or other propagation into the atmosphere and includes, but is not limited to, smoke, charred paper, dust, soot, grime, carbon, fumes, gases, odors, particulate matter, acids, or any combination thereof.

Added Stats 1975 ch 957 § 12. Amended Stats 1976 ch 1063 § 4.5, effective September 21, 1976.

**§ 39014. “Ambient air quality standards”**

“Ambient air quality standards” means specified concentrations and durations of air pollutants which reflect the relationship between the intensity and composition of air pollution to undesirable effects established by the state board or, where applicable, by the federal government.

Added Stats 1975 ch 957 § 12.

**§ 39016.5. “Bureau”**

“Bureau” means the Bureau of Automotive Repair in the Department of Consumer Affairs.

Added Stats 2000 ch 890 § 2 (AB 2939).

**§ 39018. “Certification”**

“Certification” means a finding by the state board that a motor vehicle, motor vehicle engine, or motor vehicle pollution control device has satisfied the criteria adopted by the state board for the control of specified air contaminants from vehicular sources.

Added Stats 1975 ch 957 § 12.

**§ 39019. “Certified device”**

“Certified device” means a motor vehicle pollution control device with a certification, and includes a motor vehicle pollution control device previously accredited or approved by the state board or by the Motor Vehicle Pollution Control Board.

The term “accredited” or “approved” may continue to be used with respect to such devices previously accredited or approved.

Added Stats 1975 ch 957 § 12.

**§ 39021. “Commercial vehicle”**

“Commercial vehicle” has the same meaning as defined in Section 260 of the Vehicle Code.

Added Stats 1975 ch 957 § 12.

**§ 39024.5. “Department”**

“Department” means the Department of Consumer Affairs.

Added Stats 1982 ch 892 § 1.2.

**§ 39024.6. “Direct import vehicle”**

“Direct import vehicle” means any light-duty motor vehicle manufactured outside of the United States which was not intended by the manufacturer for sale in the United States and which was not certified by the state board pursuant to Article 1 (commencing with Section 43100) of Chapter 2 of Part 5.

Added Stats 1989 ch 859 § 1.

**§ 39025. “District”**

“District” means an air pollution control district or an air quality management district created or continued in existence pursuant to provisions of Part 3 (commencing with Section 40000).

Added Stats 1975 ch 957 § 12. Amended Stats 1976 ch 324 § 2.

**§ 39027. “Emission standards”**

“Emission standards” means specified limitations on the discharge of air contaminants into the atmosphere.

Added Stats 1975 ch 957 § 12.

**§ 39027.3. Definitions**

(a) “Bidirectional control” means the capability of a diagnostic tool to send messages on the data (bus) that temporarily overrides the module’s control over a sensor or actuator and gives control to the diagnostic tool operator. Bidirectional controls do not create permanent changes to engine or component calibrations.

(b) “Covered person” means any person engaged in the business of service or repair of motor vehicles who is licensed or registered with the Bureau of Automotive Repair, pursuant to Section 9884.6 of the Business and Professions Code, to conduct that business, or who is engaged in the manufacture or remanufacture of emissions-related motor vehicle parts for those motor vehicles.

(c) “Data stream information” means information that originates within the vehicle by a module or intelligent sensors including, but not limited to, a sensor that contains and is controlled by its own module and transmitted between a network of modules and intelligent sensors connected in parallel with either one or two communication wires. The information is broadcast over communication wires for use by other modules such as chassis or transmissions to conduct normal vehicle operation or for use by diagnostic tools. Data stream information does not include engine calibration-related information.

(d) “Emissions-related motor vehicle information” means information regarding any of the following:

(1) Any original equipment system, component, or part that controls emissions.

(2) Any original equipment system, component, or part associated with the powertrain system including, but not limited to, the fuel system and ignition system.

(3) Any original equipment system or component that is likely to impact emissions, including, but not limited to, the transmission system.

(e) "Emissions-related motor vehicle part" means any direct replacement automotive part or any automotive part certified by executive order of the state board that may affect emissions from a motor vehicle, including replacement parts, consolidated parts, rebuilt parts, remanufactured parts, add-on parts, modified parts, and specialty parts.

(f) "Enhanced data stream information" means data stream information that is specific for an original equipment manufacturer's brand of tools and equipment.

(g) "Enhanced diagnostic tool" means a diagnostic tool that is specific to the original equipment manufacturer's vehicles.

Added Stats 2000 ch 1077 § 2 (SB 1146).

**§ 39027.5. (Operative date contingent; Operative term contingent) "Emissions retrofit device"**

(a) "Emissions retrofit device" means an exhaust device certified pursuant to Section 43630 or approved for use pursuant to Section 27156 of the Vehicle Code which renders a modified vehicle a low-emission motor vehicle, as defined by Section 43800.

(b) This section shall become inoperative five years from the date determined pursuant to Section 32 of the act adding this section, and on the January 1 following that date is repealed.

Added Stats 1994 ch 1192 § 4 (SB 2050), operation contingent.

**Note**—Stats 1994 ch 1192 provides:

SEC. 32. (a) This act, except Section 29, shall not become operative until both of the following occur:

(1) The system required by subdivision (b) of Section 44060 of the Health and Safety Code for the electronic filing of certificates of compliance or noncompliance is determined to be operational by the Department of Consumer Affairs and that fact is reported by the department to the Secretary of State.

(2) The San Diego County Air Pollution Control District and the Ventura County Air Pollution Control District have sufficient funds available to implement the pilot program established pursuant to subdivision (b) of Section 43705 of the Health and Safety Code, as determined by each of those districts and reported by each district to the Secretary of State.

(b) On the date that all of the reports have been received by the Secretary of State pursuant to subdivision (a), subject to the exceptions stated in Section 33 of this act, this act shall be operative.

**§ 39028. "Exhaust device"**

"Exhaust device" means a motor vehicle pollution control device to reduce exhaust emissions.

Added Stats 1975 ch 957 § 12.

**§ 39029. "Exhaust emissions"**

"Exhaust emissions" means substances emitted to the atmosphere from any opening downstream from the exhaust port of a motor vehicle engine.

Added Stats 1975 ch 957 § 12.

**§ 39032.5. "Gross polluter"**

"Gross polluter" means a vehicle with excess hydrocarbon, carbon monoxide, or oxides of nitrogen emissions as

established by the department in consultation with the state board.

Added Stats 1994 ch 27 § 1 (AB 2018), effective March 30, 1994.

**§ 39033. "Heavy-duty"**

"Heavy-duty" means having a manufacturer's maximum gross vehicle weight rating of 6,001 or more pounds.

Added Stats 1975 ch 957 § 12. Amended Stats 1976 ch 1063 § 5, effective September 21, 1976.

**§ 39035. "Light-duty"**

"Light-duty" means having a manufacturer's maximum gross vehicle weight rating of under 6,001 pounds.

Added Stats 1975 ch 9547 § 12. Amended Stats 1976 ch 1063 § 6, effective September 21, 1976.

**§ 39037.05. "Low-emission motor vehicle"**

"Low-emission motor vehicle" means a motor vehicle which has been certified by the state board to meet all applicable emission standards and which meets at least one of the following additional requirements:

(a) Is capable of operating on methanol, as determined by the state board, and will have an adverse impact on ambient ozone air quality not greater than a vehicle which meets the requirements of subdivision (c).

(b) Is capable of operating on any available fuel other than gasoline or diesel and, in the determination of the state board, will have an adverse impact on ambient ozone air quality not greater than a vehicle operating on methanol.

(c) Operates exclusively on gasoline and is certified to meet a hydrocarbon exhaust emission standard which is at least twice as stringent as otherwise applicable to gasoline vehicles of the same year and class.

Added Stats 1987 ch 1326 § 1. Amended Stats 1989 ch 796 § 2.

**§ 39037.5. "Medium duty"**

"Medium duty" means a heavy-duty vehicle having a manufacturer's gross vehicle weight rating under a limit established by the state board.

Added Stats 1988 ch 1544 § 6.

**§ 39038. "Model year"**

"Model year" means the manufacturer's annual production period which includes January 1 of a calendar year or, if the manufacturer has no annual production period, the calendar year.

In the case of any vehicle manufactured in two or more stages, the time of manufacture shall be the date of completion of the chassis.

Added Stats 1975 ch 957 § 12.

**§ 39039. "Motor vehicle"**

"Motor vehicle" has the same meaning as defined in Section 415 of the Vehicle Code.

Added Stats 1975 ch 957 § 12.

**§ 39040. "Motor vehicle pollution control device"**

"Motor vehicle pollution control device" means equipment designed for installation on a motor vehicle for the purpose of reducing the air contaminants emitted from the vehicle, or a system or engine modification on a

motor vehicle which causes a reduction of air contaminants emitted from the vehicle.

Added Stats 1975 ch 957 § 12.

**§ 39041. “Motorcycle”**

“Motorcycle” has the same meaning as defined in Section 400 of the Vehicle Code.

Added Stats 1975 ch 957 § 12.

**§ 39042. “New motor vehicle”**

“New motor vehicle” means a motor vehicle, the equitable or legal title to which has never been transferred to an ultimate purchaser.

Added Stats 1975 ch 957 § 2. Amended Stats 1976 ch 1206 § 2.

**§ 39042.5. “New motor vehicle engine”**

“New motor vehicle engine” means a new engine in a motor vehicle.

Added Stats 1976 ch 1206 § 3.

**§ 39046. “Passenger vehicle”**

“Passenger vehicle” has the same meaning as defined in Section 465 of the Vehicle Code.

Added Stats 1975 ch 957 § 12.

**§ 39053. “State Board”**

“State board” means the State Air Resources Board.

Added Stats 1975 ch 957 § 12. Amended Stats 2013 ch 76 § 115 (AB 383), effective January 1, 2014.

**§ 39058. “Used motor vehicle”**

“Used motor vehicle” means any motor vehicle which is not a new motor vehicle.

Added Stats 1975 ch 957 § 12. Amended Stats 1976 ch 1206 § 5.

**§ 39059. “Vehicle”**

“Vehicle” has the same meaning as defined in Section 670 of the Vehicle Code.

Added Stats 1975 ch 957 § 12.

**§ 39060. “Vehicular sources”**

“Vehicular sources” means those sources of air contaminants emitted from motor vehicles.

Added Stats 1975 ch 957 § 12.

**PART 2**

**State Air Resources Board**

**CHAPTER 3**

**General Powers and Duties**

Section  
39602. Designated air pollution control agency; Compliance with federal law

**§ 39602. Designated air pollution control agency; Compliance with federal law**

The state board is designated the air pollution control agency for all purposes set forth in federal law.

The state board is designated as the state agency responsible for the preparation of the state implementa-

tion plan required by the Clean Air Act (42 U.S.C., Sec. 7401, et seq.) and, to this end, shall coordinate the activities of all districts necessary to comply with that act.

Notwithstanding any other provision of this division, the state implementation plan shall only include those provisions necessary to meet the requirements of the Clean Air Act.

Added Stats 1975 ch 957 § 12. Amended Stats 1976 ch 1063 § 17, effective September 21, 1976; Stats 1979 ch 810 § 2, effective September 19, 1979.

**PART 3**

**Air Pollution Control Districts**

**CHAPTER 4**

**Bay Area Air Quality Management District**

**ARTICLE 3**

**Governing Body**

Section  
40221.5. Members of board

**§ 40221.5. Members of board**

(a) The members of the bay district board shall be appointed as follows:

(1) For a county entitled to appoint one member of the bay district board, the board of supervisors shall appoint either a member of the board of supervisors or a person from a list submitted to the board of supervisors by the city selection committee of that county.

(2) For a county entitled to appoint two members of the bay district board, the city selection committee of that county shall appoint one member and the board of supervisors shall appoint the other member, which member may either be a member of the board of supervisors or a person on the list submitted to the board of supervisors by the city selection committee.

(3) For a county entitled to appoint three members of the bay district board, two members shall be appointed as provided in paragraph (2) and the third member shall be appointed by the board of supervisors and shall either be a member of the board of supervisors or a person on the list submitted to the board of supervisors by the city selection committee of that county.

(4) For a county entitled to appoint four members of the bay district board, the city selection committee of that county shall appoint two members and the board of supervisors shall appoint the other two members, either one or both of whom may be members of the board of supervisors or persons on the list submitted to the board of supervisors by the city selection committee.

(b) Any member of the bay district board appointed, and any person named on the list submitted to the board of supervisors by the city selection committee, shall be either a mayor or a city councilperson of a city in that portion of the county included within the district. The member appointed by a city selection committee pursu-



ant to paragraph (3) of subdivision (a) or Section 40212 may designate a deputy to act on his or her behalf on the bay district board or any of its committees. The board member shall be responsible for the acts of the deputy acting in his or her official capacity on the bay district board or any of its committees under this designation.

Added Stats 1976 ch 517 § 4. Amended Stats 2002 ch 1001 § 1 (AB 2637).

## CHAPTER 11

### Sacramento Metropolitan Air Quality Management District

#### ARTICLE 7

#### Financial Provisions

##### Section

41081. (First of two; Repealed January 1, 2024) Surcharge on vehicle registration fees

41081. (Second of two; Operative January 1, 2024) Surcharge on vehicle registration fees

#### § 41081. (First of two; Repealed January 1, 2024) Surcharge on vehicle registration fees

(a) Subject to Article 3.7 (commencing with Section 53720) of Chapter 4 of Part 1 of Division 2 of Title 5 of the Government Code, or with the approval of the board of supervisors of each county included, in whole or in part, within the Sacramento district, the Sacramento district board may adopt a surcharge on the motor vehicle registration fees applicable to all motor vehicles registered in those counties within the Sacramento district whose boards of supervisors have adopted a resolution approving the surcharge. The surcharge shall be collected by the Department of Motor Vehicles and, after deducting the department's administrative costs, the remaining funds shall be transferred to the Sacramento district. Prior to the adoption of any surcharge pursuant to this subdivision, the district board shall make a finding that any funds allocated to the district as a result of the adoption of a county transportation sales and use tax are insufficient to carry out the purposes of this chapter.

(b) The surcharge shall not exceed six dollars (\$6).

(c) After consulting with the Department of Motor Vehicles on the feasibility thereof, the Sacramento district board may provide, in the surcharge adopted pursuant to subdivision (a), to exempt from all or part of the surcharge any category of low-emission motor vehicle.

(d) Funds received by the Sacramento district pursuant to this section shall be used by that district as follows:

(1) The revenues resulting from the first four dollars (\$4) of each surcharge shall be used to implement reductions in emissions from vehicular sources, including, but not limited to, a clean fuels program and motor vehicle use reduction measures.

(2) The revenues resulting from the next two dollars (\$2) of each surcharge shall be used to implement the following programs that achieve emission reductions from vehicular sources and off-road engines, to the extent that the district determines the program remedi-

ates air pollution harms created by motor vehicles on which the surcharge is imposed:

(A) Projects eligible for grants under the Carl Moyer Memorial Air Quality Standards Attainment Program (Chapter 9 (commencing with Section 44275) of Part 5).

(B) The new purchase, retrofit, repower, or add-on of equipment for previously unregulated agricultural sources of air pollution, as defined in Section 39011.5, within the Sacramento district, for a minimum of three years from the date of adoption of an applicable rule or standard, or until the compliance date of that rule or standard, whichever is later, if the state board has determined that the rule or standard complies with Sections 40913, 40914, and 41503.1, after which period of time, a new purchase, retrofit, repower, or add-on of equipment shall not be funded pursuant to this chapter. The district shall follow any guidelines developed under subdivision (a) of Section 44287 for awarding grants under this program.

(C) The purchase of new, or retrofit of emissions control equipment for existing, schoolbuses pursuant to the Lower-Emission School Bus Program adopted by the state board.

(D) An accelerated vehicle retirement or repair program that is adopted by the state board pursuant to authority granted hereafter by the Legislature by statute.

(E) The replacement of onboard natural gas fuel tanks on schoolbuses owned by a school district that are 14 years or older, not to exceed twenty thousand dollars (\$20,000) per bus, pursuant to the Lower-Emission School Bus Program adopted by the state board.

(F) The enhancement of deteriorating natural gas fueling dispensers of fueling infrastructure operated by a school district with a one-time funding amount not to exceed five hundred dollars (\$500) per dispenser, pursuant to the Lower-Emission School Bus Program adopted by the state board.

(e) Not more than 5 percent of the funds collected pursuant to this section shall be used by the district for administrative expenses.

(f) A project funded by the program shall not be used for credit under any state or federal emissions averaging, banking, or trading program. An emission reduction generated by the program shall not be used as marketable emission reduction credits or to offset any emission reduction obligation of any person or entity. Projects involving new engines that would otherwise generate marketable credits under state or federal averaging, banking, and trading programs shall include transfer of credits to the engine end user and retirement of those credits toward reducing air emissions in order to qualify for funding under the program. A purchase of a low-emission vehicle or of equipment pursuant to a corporate or a controlling board's policy, but not otherwise required by law, shall generate surplus emissions reductions and may be funded by the program.

(g) This section shall remain in effect only until January 1, 2024, and as of that date is repealed, unless a later enacted statute, that is enacted before January 1, 2024, deletes or extends that date.

Added Stats 1988 ch 1541 § 3. Amended Stats 2004 ch 707 § 2 (AB 923), repealed January 1, 2015; Stats 2011 ch 174 § 1 (AB 470), effective January 1, 2012, repealed January 1, 2015, ch 216 § 1.5 (AB 462),

effective January 1, 2012, repealed January 1, 2015; Stats 2013 ch 401 § 1 (AB 8), effective September 28, 2013, repealed January 1, 2024.

**§ 41081. (Second of two; Operative January 1, 2024) Surcharge on vehicle registration fees**

(a) Subject to Article 3.7 (commencing with Section 53720) of Chapter 4 of Part 1 of Division 2 of Title 5 of the Government Code, or with the approval of the board of supervisors of each county included, in whole or in part, within the Sacramento district, the Sacramento district board may adopt a surcharge on the motor vehicle registration fees applicable to all motor vehicles registered in those counties within the Sacramento district whose boards of supervisors have adopted a resolution approving the surcharge. The surcharge shall be collected by the Department of Motor Vehicles and, after deducting the department's administrative costs, the remaining funds shall be transferred to the Sacramento district. Prior to the adoption of any surcharge pursuant to this subdivision, the district board shall make a finding that any funds allocated to the district as a result of the adoption of a county transportation sales and use tax are insufficient to carry out the purposes of this chapter.

(b) The surcharge shall not exceed four dollars (\$4).

(c) After consulting with the Department of Motor Vehicles on the feasibility thereof, the Sacramento district board may provide, in the surcharge adopted pursuant to subdivision (a), to exempt from all or part of the surcharge any category of low-emission motor vehicle.

(d) Funds received by the Sacramento district pursuant to this section shall be used to implement the strategy with respect to the reduction in emissions from vehicular sources, including, but not limited to, a clean fuels program and motor vehicle use reduction measures. Not more than 5 percent of the funds collected pursuant to this section shall be used by the district for administrative expenses.

(e) This section shall become operative on January 1, 2024.

Added Stats 2004 ch 707 § 2.5 (AB 923), operative January 1, 2015. Amended Stats 2013 ch 401 § 2 (AB 8), effective September 28, 2013, operative January 1, 2024.

**PART 5**

**Vehicular Air Pollution Control**

**CHAPTER 1**

**General Provisions**

Section

43012. Right of entry for inspection; Notice to correct; Display of disclosure; Civil penalties

43013. Adoption of standards to carry out purposes of division

43013.2. Variances from state board's gasoline specifications

**§ 43012. Right of entry for inspection; Notice to correct; Display of disclosure; Civil penalties**

(a) For the purpose of enforcing or administering any federal, state, or local law, order, regulation, or rule relating to vehicular sources of emissions, the executive officer of the state board or an authorized representative of the executive officer, or a representative of the depart-

ment, upon presentation of credentials or, if necessary under the circumstances, after obtaining an inspection warrant pursuant to Title 13 (commencing with Section 1822.50) of Part 3 of the Code of Civil Procedure, has the right of entry to any premises owned, operated, used, leased, or rented by any new or used car dealer, as defined in Sections 285, 286, and 426 of the Vehicle Code, for the purpose of inspecting any vehicle for which emissions standards have been enacted or adopted or for which emissions equipment is required and which is situated on the premises for the purpose of emission-related maintenance, repair, or service, or for the purpose of sale, lease, or rental, whether or not the vehicle is owned by the dealer. The inspection may extend to all emission-related parts and operations of the vehicle, and may require the on-premises operation of an engine or vehicle, the on-premises securing of samples of emissions from the vehicle, and the inspection of any records which relate to vehicular emissions required by the Environmental Protection Agency or by any state or local law, order, regulation, or rule to be maintained by the dealer in connection with the dealer's business.

(b) The right of entry for inspection under this section is limited to the hours during which the dealer is open to the public, except when the entry is made pursuant to warrant or whenever the executive officer or an authorized representative, or a representative of the department, has reasonable cause to believe that a violation of any federal, state, or local law, order, regulation, or rule has been committed in his or her presence. No vehicle shall be inspected pursuant to this section more than one time without an inspection warrant or without reasonable cause unless the vehicle undergoes a change of ownership or the inspection reveals that the vehicle has failed to comply with required emissions standards or equipment, in which case one additional inspection may be made to verify the violation or to verify that the violation has been corrected.

(c) With respect to vehicles not owned by the dealer, the state board or the department may not prosecute, without the owner's knowledge or consent, any violation by the owner of any law pertaining to vehicular emissions unless prior notice of the inspection has been given to the owner.

(d) If the executive officer or authorized representative, or a representative of the department, upon inspection, finds that a used motor vehicle fails to comply with applicable emissions standards or equipment, the state board or the department shall issue a notice to correct and enter the appropriate vehicle information into the centralized computer data base created pursuant to Section 44037.1. Until all violations in the notice have been corrected and the dealer has sent proof of correction by certified mail to the state board or the department, whichever issued the notice, the motor vehicle shall prominently display the following disclosure affixed to the windshield in at least 18-point type:

NOT FOR SALE

THIS VEHICLE IS PRESENTLY NOT IN COMPLIANCE WITH THE CALIFORNIA VEHICLE POLLUTION CONTROL LAWS AND MAY NOT BE SOLD

**UNTIL A VALID CERTIFICATE OF COMPLIANCE HAS BEEN ISSUED.**

Any dealer who sells a vehicle prohibited to be sold under this subdivision is subject to a civil penalty of not to exceed one thousand dollars (\$1,000). For purposes of this subdivision, "proof of correction" shall consist of a copy of a certificate of compliance or noncompliance issued following the issuance of a notice to correct by a licensed test station or licensed repair station not affiliated with or owned by the dealer or any other proof of repair satisfactory to the inspecting officer. The dealer shall send the copy of the certificate of compliance or noncompliance by certified mail to the state board or the department, whichever issued the notice, within three days of obtaining the certificate.

(e) Civil penalties may be assessed or recovered for one or more violations by a dealer involving the tampering with or disabling of a vehicle's air injection exhaust gas recirculation, crankcase ventilation, fuel injection or carburetion systems, ignition timing or evaporative controls, fuel filler neck restrictor, oxygen sensor or electronic controls, or missing catalytic converter.

(f) No civil penalty or criminal penalty may be assessed for a violation by a dealer identified in a notice to correct as a result of an inspection under this section if the violation is related to lack of maintenance or customer tampering or vandalism, including, but not limited to, a missing gasoline filler cap and a disconnected or missing heated air intake tube or vacuum hose. However, if notices to correct are issued under this subdivision to more than 20 percent of the vehicles offered for sale on a dealer's premises during each of three consecutive inspections conducted 30 or more days apart during any one-year period, civil penalties may be assessed and recovered for each vehicle issued a notice to correct.

(g) If the executive officer or authorized representative, upon inspection, finds that a certificate of compliance or noncompliance was issued to a motor vehicle that fails to comply with applicable emissions standards or equipment, the state board shall immediately refer these findings to the department for investigation under Chapter 5 (commencing with Section 44000). The state board may refer any other suspected violation to the department for appropriate action.

(h) Notwithstanding Section 17150 of the Vehicle Code, the state shall be liable for any injury or damage caused by the negligent or wrongful act or omission of the operator of any vehicle which is operated pursuant to this section.

(i) This section provides the exclusive authority for inspections of motor vehicles for the purposes specified in this section.

(j) As used in this section, the terms "tampering" and "disabling" mean an unauthorized modification, alteration, removal, or disconnection.

Added Stats 1975 ch 957 § 12. Amended Stats 1976 ch 1063 § 50, effective September 21, 1976; Stats 1987 ch 1392 § 1; Stats 1994 ch 27 § 2 (AB 2018), effective March 30, 1994, ch 1220 § 11 (AB 3132), effective September 30, 1994.

**§ 43013. Adoption of standards to carry out purposes of division**

(a) The state board shall adopt and implement motor vehicle emission standards, in-use performance stan-

dards, and motor vehicle fuel specifications for the control of air contaminants and sources of air pollution which the state board has found to be necessary, cost effective, and technologically feasible, to carry out the purposes of this division, unless preempted by federal law.

(b) The state board shall, consistent with subdivision (a), adopt standards and regulations for light-duty and heavy-duty motor vehicles, medium-duty motor vehicles, as determined and specified by the state board, portable fuel containers and spouts, and off-road or nonvehicle engine categories, including, but not limited to, off-highway motorcycles, off-highway vehicles, construction equipment, farm equipment, utility engines, locomotives, and, to the extent permitted by federal law, marine vessels.

(c) Prior to adopting standards and regulations for farm equipment, the state board shall hold a public hearing and find and determine that the standards and regulations are necessary, cost effective, and technologically feasible. The state board shall also consider the technological effects of emission control standards on the cost, fuel consumption, and performance characteristics of mobile farm equipment.

(d) Notwithstanding subdivision (b), the state board shall not adopt any standard or regulation affecting locomotives until the final study required under Section 5 of Chapter 1326 of the Statutes of 1987 has been completed and submitted to the Governor and Legislature.

(e) Prior to adopting or amending any standard or regulation relating to motor vehicle fuel specifications pursuant to this section, the state board shall, after consultation with public or private entities that would be significantly impacted as described in paragraph (2) of subdivision (f), do both of the following:

(1) Determine the cost-effectiveness of the adoption or amendment of the standard or regulation. The cost-effectiveness shall be compared on an incremental basis with other mobile source control methods and options.

(2) Based on a preponderance of scientific and engineering data in the record, determine the technological feasibility of the adoption or amendment of the standard or regulation. That determination shall include, but is not limited to, the availability, effectiveness, reliability, and safety expected of the proposed technology in an application that is representative of the proposed use.

(f) Prior to adopting or amending any motor vehicle fuel specification pursuant to this section, the state board shall do both of the following:

(1) To the extent feasible, quantitatively document the significant impacts of the proposed standard or specification on affected segments of the state's economy. The economic analysis shall include, but is not limited to, the significant impacts of any change on motor vehicle fuel efficiency, the existing motor vehicle fuel distribution system, the competitive position of the affected segment relative to border states, and the cost to consumers.

(2) Consult with public or private entities that would be significantly impacted to identify those investigative or preventive actions that may be necessary to ensure consumer acceptance, product availability, acceptable performance, and equipment reliability. The significantly impacted parties shall include, but are not limited

to, fuel manufacturers, fuel distributors, independent marketers, vehicle manufacturers, and fuel users.

(g) To the extent that there is any conflict between the information required to be prepared by the state board pursuant to subdivision (f) and information required to be prepared by the state board pursuant to Chapter 3.5 (commencing with Section 11340) of Part 1 of Division 3 of Title 2 of the Government Code, the requirements established under subdivision (f) shall prevail.

(h) It is the intent of the Legislature that the state board act as expeditiously as is feasible to reduce nitrogen oxide emissions from diesel vehicles, marine vessels, and other categories of vehicular and mobile sources which significantly contribute to air pollution problems.

Added Stats 1975 ch 957 § 12. Amended Stats 1976 ch 1063 § 51, effective September 21, 1976; Stats 1988 ch 1568 § 33; Stats 1990 ch 932 § 2 (AB 3555); Stats 1992 ch 945 § 16 (AB 2783); Stats 1995 ch 930 § 1 (SB 37); Stats 2007 ch 669 § 3 (SB 1028), effective January 1, 2008; Stats 2008 ch 687 § 1 (AB 2922), effective January 1, 2009.

**§ 43013.2. Variances from state board’s gasoline specifications**

(a)(1) The Legislature finds and declares that variances from the state board’s gasoline specifications may be needed if gasoline producers cannot meet the specifications as required due to circumstances beyond their reasonable control, and that the state board’s process for granting variances from fuel specifications should be clarified.

(2) It is the intent of the Legislature that the variance process consider the impacts of granting the variance on all parties, including the applicant, the public, the producers of complying fuel, and upon air quality.

(b) The state board may grant variances from gasoline specifications adopted by the state board pursuant to Sections 43013 and 43018. In granting a variance, the board may impose fees and conditions.

(c) The state board shall adopt regulations to implement this section in accordance with Chapter 3.5 (commencing with Section 11340) of Part 1 of Division 3 of Title 2 of the Government Code. The regulations shall establish guidelines for the consideration of variances and the imposition of fees and conditions. Any fees or conditions shall be imposed in a fair and equitable manner consistent with the regulations. The regulations shall include methods for estimating excess emissions and factors to be considered in determining what is beyond the reasonable control of the applicant. The regulations also shall establish a schedule of fees to be paid by an applicant for a variance to cover the reasonable and necessary costs to the state board in processing the variance. The state board shall adopt initial regulations as emergency regulations after conducting at least one public workshop. The initial adoption of emergency regulations following the effective date of this section shall be deemed to be an emergency and necessary for the immediate preservation of the public peace, health and safety, or general welfare.

(d) All variance fee revenues collected pursuant to this section by the state board, except those fees paid by an applicant for a variance to cover the reasonable and necessary costs to the state board for processing the variance, shall be transmitted to the Treasurer for deposit in the High Polluter Repair or Removal Account

created pursuant to subdivision (a) of Section 44091. All money deposited in the account pursuant to this section shall be available, upon appropriation by the Legislature, to implement a program for accelerated retirement of light-duty vehicles to achieve the emission reductions required by the M-1 Strategy of the 1994 State Implementation Plan.

(e) In considering whether to grant a variance, and with regard to any fees and conditions that are imposed as part of the variance, the state board shall take into account whether granting the variance will place the applicant at a cost advantage over other persons, including those persons who produce complying gasoline.

(f) Any determination of the state board, or the executive officer of the state board pursuant to the authority delegated pursuant to Section 39516, regarding the issuance of any variance from gasoline specifications shall be based solely upon substantial evidence in the record of the variance proceeding. The variance shall be valid for a period not exceeding 120 days, commencing on or after March 1, 1996. The variance may be extended, subject to this section, for up to 90 additional days, upon a showing of need. The board shall grant a variance only for the minimum period required to attain compliance.

(g) If a physical catastrophe occurs to a producer of complying gasoline, the state board may extend a variance upon the showing of need. Notwithstanding subdivision (f), any variance extension related to a physical catastrophe shall be approved by the state board. As used in this subdivision, “physical catastrophe” means a sudden unforeseen emergency beyond the reasonable control of the refiner, causing the severe reduction or total loss of one or more critical refinery units that materially impact the refiner’s ability to produce complying gasoline. “Physical catastrophe” does not include events which are not physical in nature such as design errors or omissions, financial or economic burdens, or any reduction in production that is not the direct result of qualifying physical damage.

(h) Notwithstanding any other provision of law, except in the case of emergency variances, the state board shall provide at least 10 days’ public notice of its consideration of any variance or extension.

(i) Subdivisions (b) and (e) do not constitute a change in, but are declaratory of, existing law.

Added Stats 1995 ch 675 § 1 (SB 709).

**CHAPTER 2**

**New Motor Vehicles**

**ARTICLE 1**

**General Provisions**

Section 43104. Test procedures  
43105.5. Adoption of regulations regarding requirements for motor vehicle manufacturers; Trade secrets; Compliance

**§ 43104. Test procedures**

For the certification of new motor vehicles or new motor vehicle engines, the state board shall adopt, by regulation, test procedures and any other procedures

necessary to determine whether the vehicles or engines are in compliance with the emissions standards established pursuant to Section 43101. The state board shall base its test procedures on federal test procedures or on driving patterns typical in the urban areas of California.

Added Stats 1975 ch 957 § 12. Amended Stats 1976 ch 1206 § 10; Stats 2000 ch 1077 § 3 (SB 1146).

**§ 43105.5. Adoption of regulations regarding requirements for motor vehicle manufacturers; Trade secrets; Compliance**

(a) For all 1994 and later model-year motor vehicles equipped with on board diagnostic systems (OBD's) and certified in accordance with the test procedures adopted pursuant to Section 43104, the state board, not later than January 1, 2002, shall adopt regulations that require a motor vehicle manufacturer to do all of the following to the extent not limited or prohibited by federal law (the regulations adopted by the state board pursuant to this provision may include subject matter similar to the subject matter included in regulations adopted by the United States Environmental Protection Agency):

(1) Make available, within a reasonable period of time, and by reasonable business means, including, but not limited to, use of the Internet, as determined by the state board, to all covered persons, the full contents of all manuals, technical service bulletins, and training materials regarding emissions-related motor vehicle information that is made available to their franchised dealerships.

(2) Make available for sale to all covered persons the manufacturer's emissions-related enhanced diagnostic tools, and make emissions-related enhanced data stream information and bidirectional controls related to tools available in electronic format to equipment and tool companies.

(3) If the motor vehicle manufacturer uses reprogrammable computer chips in its motor vehicles, provide equipment and tool companies with the information that is provided by the manufacturer to its dealerships to allow those companies to incorporate into aftermarket tools the same reprogramming capability.

(4) Make available to all covered persons, within a reasonable period of time, a general description of their on board diagnostic systems (OBD II) for the 1996 and subsequent model-years, which shall contain the information described in this paragraph. For each monitoring system utilized by a manufacturer that illuminates the OBD II malfunction indicator light, the motor vehicle manufacturer shall provide all of the following:

(A) A general description of the operation of the monitor, including a description of the parameter that is being monitored.

(B) A listing of all typical OBD II diagnostic trouble codes associated with each monitor.

(C) A description of the typical enabling conditions for each monitor to execute during vehicle operation, including, but not limited to, minimum and maximum intake air and engine coolant temperature, vehicle speed range, and time after engine startup.

(D) A listing of each monitor sequence, execution frequency, and typical duration.

(E) A listing of typical malfunction thresholds for each monitor.

(F) For OBD II parameters for specific vehicles that deviate from the typical parameters, the OBD II description shall indicate the deviation and provide a separate listing of the typical value for those vehicles.

(G) The information required by this paragraph shall not include specific algorithms, specific software code, or specific calibration data beyond that required to be made available through the generic scan tool in federal and California on board diagnostic regulations.

(5) Not utilize any access or recognition code or any type of encryption for the purpose of preventing a vehicle owner from using an emissions-related motor vehicle part with the exception of the powertrain control modules, engine control modules, and transmission control modules, that has not been manufactured by that manufacturer or any of its original equipment suppliers.

(6) Provide to all covered persons information regarding initialization procedures relating to immobilizer circuits or other lockout devices to reinitialize vehicle on board computers that employ integral vehicle security systems if necessary to repair or replace an emissions-related part, or if necessary for the proper installation of vehicle on board computers that employ integral vehicle security systems.

(7) All information required to be provided to covered persons by this section shall be provided, for fair, reasonable, and nondiscriminatory compensation, in a format that is readily accessible to all covered persons, as determined by the state board.

(b) Any information required to be disclosed pursuant to a final regulation adopted under this section that the motor vehicle manufacturer demonstrates to a court, on a case-by-case basis, to be a trade secret pursuant to the Uniform Trade Secret Act contained in Title 5 (commencing with Section 3426) of Part 1 of Division 4 of the Civil Code, shall be exempt from disclosure, unless the court, upon the request of a covered person seeking disclosure of the information, determines that the disclosure of the information is necessary to mitigate anticompetitive effects. In making this determination, the court shall consider, among other things, the practices of any motor vehicle manufacturer that results in the fullest disclosure of information listed in paragraph (4) of subdivision (a). In actions subject to this subdivision, the court shall preserve the secrecy of an alleged trade secret by reasonable means, which may include granting a protective order in connection with discovery proceedings, holding an in-camera hearing, sealing the record of the action, or ordering any person involved in the litigation not to disclose an alleged trade secret without prior court approval.

(c) If information is required to be disclosed by a motor vehicle manufacturer pursuant to subdivision (b), the court shall allow for the imposition of reasonable business conditions as a condition of disclosure, and may include punitive sanctions for the improper release of information that is determined to be a trade secret to a competitor of the manufacturer. The court shall also provide for fair, reasonable, and nondiscriminatory compensation to the motor vehicle manufacturer for the disclosure of information determined by the court to be a trade secret and required to be disclosed pursuant to

subdivision (b). The court shall provide for the dissemination of trade secret information required to be disclosed pursuant to subdivision (b) through licensing agreements and the collection of reasonable licensing fees. If the court determines that disclosure of any of the information required to be disclosed under subdivision (b) constitutes a taking of personal property, a jury trial shall be held to determine the amount of compensation for that taking, unless waived by the motor vehicle manufacturer.

(d) The state board shall periodically conduct surveys to determine whether the information requirements imposed by this section are being fulfilled by actual field availability of the information.

(e) If the executive officer of the state board obtains credible evidence that a motor vehicle manufacturer has failed to comply with any of the requirements of this section or the regulations adopted by the state board, the executive officer shall issue a notice to comply to the manufacturer. Not later than 30 days after issuance of the notice to comply, the vehicle manufacturer shall submit to the executive officer a compliance plan, unless within that 30-day period the manufacturer requests an administrative hearing to contest the basis or scope of the notice to comply in accordance with subdivision (f). The executive officer shall accept the compliance plan if it provides adequate demonstration that the manufacturer will come into compliance with this section and the board's implementing regulations within 45 days following submission of the plan. However, the executive officer may extend the compliance period if the executive officer determines that the violation cannot be remedied within that period.

(f) If the motor vehicle manufacturer contests a notice to comply pursuant to subdivision (e) or the executive officer rejects the compliance plan submitted by the manufacturer, an administrative hearing shall be conducted by a hearing officer appointed by the state board, in accordance with procedures established by the state board. The hearing procedures shall provide the manufacturer and any other interested party at least 30 days notice of the hearing. If, after the hearing, the hearing officer appointed by the state board finds that the motor vehicle manufacturer has failed to comply with any of the requirements of this section or the regulations adopted by the state board, and the manufacturer fails to correct the violation with 30 days from the date of the finding, the hearing officer may impose a civil penalty upon the manufacturer in an amount not to exceed twenty-five thousand dollars (\$25,000) per day per violation until the violation is corrected, as determined in accordance with the hearing procedures established by the state board. The hearing procedures may provide additional time for compliance prior to imposing a civil penalty. If so, the hearing officer may grant additional time for compliance if he or she determines that the violation cannot be remedied within 30 days of the finding that a violation has occurred.

(g) Nothing in this section is intended to authorize the infringement of intellectual property rights embodied in United States patents, trademarks, or copyrights, to the extent those rights may be exercised consistently with any other federal laws.

Added Stats 2000 ch 1077 § 4 (SB 1146). Amended Stats 2012 ch 728 § 90 (SB 71), effective January 1, 2013.

## ARTICLE 1.5

### Prohibited Transactions

#### Section

43150. Legislative findings and declarations

43151. Acquisition of vehicle or engine outside of state

43152. Acquisition of non-certified vehicle or engine for sale or resale

43153. Sale or lease of non-certified vehicle or engine

43154. Action for civil penalty

43155. Action for civil penalty; Precedence

43156. Presumption as to transfer of title based on odometer reading

#### § 43150. Legislative findings and declarations

The Legislature finds and declares that the people of this state, in order to achieve the purposes of this part, have a special interest in assuring that only those new motor vehicles and new motor vehicle engines which meet this state's stringent emission standards and test procedures, and which have been certified pursuant to this chapter, are used or registered in this state. The Legislature also finds and declares that this special interest must be protected in a manner which will not unduly or unreasonably infringe upon the right of the people of this state and other states to travel and do business interstate.

Added Stats 1976 ch 1206 § 13.

#### § 43151. Acquisition of vehicle or engine outside of state

(a) No person who is a resident of, or who operates an established place of business within, this state shall import, deliver, purchase, rent, lease, acquire, or receive a new motor vehicle, new motor vehicle engine, or motor vehicle with a new motor vehicle engine for use, registration, or resale in this state unless such motor vehicle engine or motor vehicle has been certified pursuant to this chapter. No person shall attempt or assist in any such action.

(b) This article shall not apply to a vehicle acquired by a resident of this state for the purpose of replacing a vehicle registered to such resident which was damaged or became inoperative beyond reasonable repair or was stolen while out of this state; provided that such replacement vehicle is acquired out of state at the time the previously owned vehicle was either damaged or became inoperative or was stolen. This article shall not apply to a vehicle transferred by inheritance, or by a decree of divorce, dissolution, or legal separation entered by a court of competent jurisdiction, or to any vehicle sold after the effective date of the amendments to this subdivision at the 1979–80 Regular Session of the Legislature if the vehicle was registered in this state before such effective date.

(c) This chapter shall not apply to any motor vehicle having a certificate of conformity issued pursuant to the Clean Air Act (42 U.S.C. Sec. 7401 et seq.) and originally registered in another state by a resident of that state who subsequently establishes residence in this state and who, upon registration of the vehicle in this state, provides satisfactory evidence to the Department of Motor Vehicles of the previous residence and registration. This subdivision shall become operative 180 calendar days after the state board adopts regulations for the certification of new direct import vehicles pursuant to Section 43203.5.

(d) "Established place of business," as used in this section, means a place actually occupied either continuously or at regular periods.

Added Stats 1976 ch 1206 § 13. Amended Stats 1978 ch 1370 § 1; Stats 1980 ch 1181 § 1, effective September 29, 1980; Stats 1985 ch 1235 § 1.

**§ 43152. Acquisition of non-certified vehicle or engine for sale or resale**

No person who is engaged in this state in the business of selling to an ultimate purchaser, or renting or leasing new motor vehicles or new motor vehicle engines, including, but not limited to, manufacturers, distributors, and dealers, shall intentionally or negligently import, deliver, purchase, receive, or otherwise acquire a new motor vehicle, new motor vehicle engine, or vehicle with a new motor vehicle engine which is intended for use primarily in this state, for sale or resale to an ultimate purchaser who is a resident of or doing business in this state, or for registration, leasing or rental in this state, which has not been certified pursuant to this chapter. No person shall attempt or assist in any such act.

Added Stats 1976 ch 1206 § 13.

**§ 43153. Sale or lease of non-certified vehicle or engine**

No person who is engaged in this state in the business of selling to an ultimate purchaser or renting or leasing new motor vehicles or new motor vehicle engines, including, but not limited to, manufacturers, distributors, and dealers, shall intentionally or negligently sell, or offer to sell, to an ultimate purchaser who is a resident of or doing business in this state, or lease, offer to lease, rent, or offer to rent, in this state any new motor vehicle, new motor vehicle engine, or vehicle with a new motor vehicle engine, which is intended primarily for use or for registration in this state, and which has not been certified pursuant to this chapter. No person shall attempt or assist in any such action.

Added Stats 1976 ch 1206 § 13.

**§ 43154. Action for civil penalty**

(a) Any person who violates any provision of this article shall be liable for a civil penalty not to exceed five thousand dollars (\$5,000) per vehicle.

(b) Any action to recover a penalty under this section shall be brought in the name of the people of the State of California in the superior court of the county where the violation occurred, or in the county where the defendant's residence or principal place of business is located, by the Attorney General on behalf of the state board, in which event all penalties adjudged by the court shall be deposited in the Air Pollution Control Fund, or by the district attorney or county attorney of such county, or by the city attorney of a city in that county, in which event all penalties adjudged by the court shall be deposited with the treasurer of the county or city, as the case may be.

Added Stats 1976 ch 1206 § 13.

**§ 43155. Action for civil penalty; Precedence**

An action brought pursuant to Section 43154 to recover such civil penalties shall take special precedence over all other civil matters on the calendar of the court

except those matters to which equal precedence on the calendar is granted by law.

Added Stats 1976 ch 1206 § 13.

**§ 43156. Presumption as to transfer of title based on odometer reading**

(a) For purposes of this article, it is conclusively presumed that the equitable or legal title to any motor vehicle with an odometer reading of 7,500 miles or more, has been transferred to an ultimate purchaser, except as provided in subdivision (b), and that the equitable or legal title to any motor vehicle with an odometer reading of less than 7,500 miles, has not been transferred to an ultimate purchaser.

(b) For purposes of this article, it is conclusively presumed that the equitable and legal title to any direct import vehicle which is less than two years old has not been transferred to an ultimate purchaser and that the equitable or legal title to any direct import motor vehicle which is at least two years old has been transferred to an ultimate purchaser.

For purposes of this subdivision, the age of a motor vehicle shall be determined by the following, in descending order of preference:

(1) From the first calendar day of the model year as indicated in the vehicle identification number.

(2) From the last calendar day of the month the vehicle was delivered by the manufacturer as shown on the foreign title document.

(3) From January 1 of the same calendar year as the model year shown on the foreign title document.

(4) From the last calendar day of the month the foreign title document was issued.

Added Stats 1985 ch 1235 § 3. Amended Stats 1988 ch 1383 § 1; Stats 1989 ch 859 § 3.

## ARTICLE 2

### Manufacturers and Dealers

Section

43204. Warranty; "Useful life"

43205. Warranty requirements for light and medium duty motor vehicles

43205.5. Warranty for motor vehicles other than light and medium duty

43210.5. Emissions-related defects

**§ 43204. Warranty; "Useful life"**

(a) The manufacturer of each motor vehicle or motor vehicle engine manufactured prior to the 1990 model-year shall warrant to the ultimate purchaser and each subsequent purchaser that the motor vehicle or motor vehicle engine is:

(1) Designed, built, and equipped so as to conform, at the time of sale, with the applicable emission standards specified in this part.

(2) Free from defects in materials and workmanship which cause such motor vehicle or motor vehicle engine to fail to conform with applicable regulations for its useful life, determined pursuant to subdivision (b).

(b) As used in subdivision (a), "useful life" of a motor vehicle or motor vehicle engine means:

(1) In the case of light-duty motor vehicles, and motor vehicle engines used in such motor vehicles, a period of use of five years or 50,000 miles, whichever first occurs,

except that, in the case of fuel metering and ignition systems and their component parts which are contained in the state board's "Emissions Warranty Parts List" dated December 14, 1978 (items I(A), I(C), III(A), III(C), III(E), IX(A), and IX(B)), and which are contained in vehicles or vehicle engines certified to the optional standards pursuant to Section 43101.5 and subject to subdivision (a) of Section 43009.5, "useful life" means a period of use of two years or 24,000 miles, whichever occurs first.

(2) In the case of any other motor vehicle or motor vehicle engine, a period of use of five years or 50,000 miles, whichever first occurs, unless the state board determines that a period of use of greater duration or mileage is appropriate.

Added Stats 1975 ch 957 § 12. Amended Stats 1976 ch 1063 § 55, effective September 21, 1976; Stats 1982 ch 1173 § 2; Stats 1988 ch 1544 § 12.

**§ 43205. Warranty requirements for light and medium duty motor vehicles**

(a) Commencing with the 1990 model-year, the manufacturer of each light-duty and medium-duty motor vehicle and motor vehicle engine shall warrant to the ultimate purchaser and each subsequent purchaser that the motor vehicle or motor vehicle engine meets all of the following requirements:

(1) Is designed, built, and equipped so as to conform with the applicable emissions standards specified in this part.

(2) Is free from defects in materials and workmanship which cause the motor vehicle or motor vehicle engine to fail to conform with applicable requirements specified in this part for three years or 50,000 miles, whichever first occurs.

(3) Will, for a period of three years or 50,000 miles, whichever first occurs, pass a test established under Section 44012, but that the warranty shall not apply if the manufacturer demonstrates that the failure of the motor vehicle or motor vehicle engine to pass the test was directly caused by the abuse, neglect, or improper maintenance or repair of the vehicle or engine.

(4) Is free from defects in materials and workmanship in emission related parts which, at the time of certification by the state board, are estimated by the manufacturer to cost individually more than three hundred dollars (\$300) to replace, for a period of seven years or 70,000 miles, whichever first occurs.

(b) The state board shall, by regulation, periodically revise the three hundred dollar (\$300) replacement cost level specified in paragraph (4) of subdivision (a) in accordance with the consumer price index, as published by the United States Bureau of Labor Statistics.

(c) For purposes of this section and Sections 43204 and 43205.5, a motorcycle is not a light-duty vehicle.

Added Stats 1988 ch 1544 § 13. Amended Stats 1989 ch 1154 § 4.

**§ 43205.5. Warranty for motor vehicles other than light and medium duty**

Commencing with the 1990 model-year, the manufacturer of each motor vehicle and motor vehicle engine, other than a light-duty or medium-duty motor vehicle or motor vehicle engine, shall warrant to the ultimate purchaser and each subsequent purchaser that the mo-

tor vehicle or motor vehicle engine meets all of the following requirements:

(a) Is designed, built, and equipped so as to conform with the applicable emission standards specified in this part for a period of use determined by the state board.

(b) Is free from defects in materials and workmanship which cause the motor vehicle or motor vehicle engine to fail to conform with applicable requirements specified in this part for the same or lesser period of use established under subdivision (a).

Added Stats 1988 ch 1544 § 14.

**§ 43210.5. Emissions-related defects**

The state board shall, by regulation, require manufacturers of motor vehicles and motor vehicle engines to determine the extent to which emissions-related defects exist in each engine family and to recommend the diagnostic and repair procedures that can result in the identification and correction of these defects under vehicle inspection and maintenance programs.

Added Stats 1988 ch 1544 § 15.

**CHAPTER 3**

**Used Motor Vehicles**

**ARTICLE 3**

**Heavy-Duty Motor Vehicles**

Section

43700. Legislative findings and declarations

43701. Adoption of regulations; Emissions standards and procedures; Compliance by fleet; Evidence that engine met federal standards at time of manufacture

**§ 43700. Legislative findings and declarations**

The Legislature finds and declares all of the following:

(a) Significant reductions in diesel emissions from existing vehicles can be achieved by the adoption of stricter diesel fuel specifications on sulfur, aromatics, and other fuel properties.

(b) The state board, in consultation with the State Department of Health Services, is evaluating the potential carcinogenic effects of specific constituents of diesel exhaust. Diesel exhaust is known to include, as constituents, many substances known or suspected to be toxic air contaminants.

(c) The Environmental Protection Agency has agreed to study the health effects of various fuels, including diesel, to determine the relative impacts on public health and the environment.

(d) Notwithstanding the ongoing study and review, reduction of emissions from diesel powered vehicles, to the maximum extent feasible, is in the best interests of air quality and public health.

Added Stats 1990 ch 1453 § 1 (SB 2330).

**§ 43701. Adoption of regulations; Emissions standards and procedures; Compliance by fleet; Evidence that engine met federal standards at time of manufacture**

(a)(1) Not later than July 15, 1992, the state board, in consultation with the bureau and the review committee



established pursuant to subdivision (a) of Section 44021, shall, after a public hearing, adopt regulations that require that owners or operators of heavy-duty diesel motor vehicles perform regular inspections of their vehicles for excessive emissions of smoke. The inspection procedure, the frequency of inspections, the emission standards for smoke, and the actions the vehicle owner or operator is required to take to remedy excessive smoke emissions shall be specified by the state board. Those standards shall be developed in consultation with interested parties. The smoke standards adopted under this subdivision shall not be more stringent than those adopted under Chapter 5 (commencing with Section 44000).

(2)(A) On or before December 31 of each year, a fleet shall comply with the regulations and standards for that calendar year.

(B) For purposes of this paragraph, “fleet” means any group of two or more heavy-duty diesel-fueled vehicles that are owned or operated by the same person.

(b) Not later than December 15, 1993, the state board shall, in consultation with the State Energy Resources Conservation and Development Commission, and after a public hearing, adopt regulations that require that heavy-duty diesel motor vehicles subject to subdivision (a) utilize emission control equipment and alternative fuels. The state board shall consider, but not be limited to, the use of cleaner burning diesel fuel, or other methods that will reduce gaseous and smoke emissions to the greatest extent feasible, taking into consideration the cost of compliance. The regulations shall provide that any significant modification of the engine necessary to meet these requirements shall be made during a regularly scheduled major maintenance or overhaul of the vehicle’s engine. If the state board requires the use of alternative fuels, it shall do so only to the extent those fuels are available.

(c) The state board shall adopt emissions standards and procedures for the qualification of any equipment used to meet the requirements of subdivision (b), and only qualified equipment shall be used.

(d) To the extent permissible under federal law, commencing January 1, 2006, the owner or operator of any commercial motor truck, as defined in Section 410 of the Vehicle Code, with a gross vehicle weight rating (GVWR) greater than 10,000 pounds that enters the state for the purposes of operating in the state shall maintain, and provide upon demand to enforcement authorities, evidence demonstrating that its engine met the federal emission standards applicable to commercial heavy-duty engines for that engine’s model-year at the time it was manufactured, pursuant to the protocol and regulations developed and implemented pursuant to subdivision (e).

(e) The state board, not later than January 1, 2006, in consultation with the Department of the California Highway Patrol, shall develop, adopt, and implement regulations establishing an inspection protocol for determining whether the engine of a truck subject to the requirements of subdivision (d) met the federal emission standard applicable to heavy-duty engines for that engine’s model-year at the time it was manufactured.

Added Stats 1990 ch 1453 § 1 (SB 2330). Amended Stats 1992 ch 674 § 5 (SB 1792); Stats 1995 ch 91 § 88 (SB 975); Stats 2004 ch 873 § 2 (AB

1009), effective September 29, 2004; Stats 2012 ch 242 § 1 (AB 1922), effective January 1, 2013.

## CHAPTER 4

### Miscellaneous

#### ARTICLE 1

#### Low-Emission Motor Vehicles

##### Section

43800. (First of two; Operative date contingent; Operative term contingent) “Low-emission motor vehicle”

43800. (Second of two; Operative date contingent) “Low-emission motor vehicle”

43801. Legislative finding and declaration

43802. Identification and labeling of low-emission motor vehicles; Exemptions from sales and use taxes

43804. Purchase by state

#### § 43800. (First of two; Operative date contingent; Operative term contingent) “Low-emission motor vehicle”

As used in this article, “low-emission motor vehicle” means a motor vehicle which has been certified by the state board to meet all applicable emission standards and which meets at least one of the following additional requirements:

(a) Is capable of operating on methanol, as determined by the state board, and will have an adverse impact on ambient ozone air quality not greater than a vehicle which meets the requirements of subdivision (c).

(b) Is capable of operating on any available fuel other than gasoline or diesel and, in the determination of the state board, will have an adverse impact on ambient ozone air quality not greater than a vehicle operating on methanol.

(c) Operates exclusively on gasoline and is certified to meet a hydrocarbon exhaust emission standard which is at least twice as stringent as otherwise applicable to gasoline vehicles of the same year and class.

(d) Is capable, in the case of a heavy-duty diesel vehicle, of meeting standards for either oxides of nitrogen or particulate matter that are twice as stringent as otherwise applicable.

(e) Has been modified from its configuration, as originally certified by the state board, by the use of an emissions retrofit device approved for use on the vehicle, and which reduces the combined emissions of ozone precursor chemicals from the vehicle by at least 30 percent.

(f) This section shall become inoperative five years from the date determined pursuant to Section 32 of the act adding this subdivision, and on the January 1 following that date is repealed.

Added Stats 1975 ch 957 § 12. Amended Stats 1989 ch 796 § 3; Stats 1994 ch 1192 § 16 (SB 2050), operation contingent.

**Editor’s Notes**—For operation of 1994 act, see the note under the second version of § 43800.

#### § 43800. (Second of two; Operative date contingent) “Low-emission motor vehicle”

As used in this article, “low-emission motor vehicle” means a motor vehicle which has been certified by the

state board to meet all applicable emission standards and which meets at least one of the following additional requirements:

(a) Is capable of operating on methanol, as determined by the state board, and will have an adverse impact on ambient ozone air quality not greater than a vehicle which meets the requirements of subdivision (c).

(b) Is capable of operating on any available fuel other than gasoline or diesel and, in the determination of the state board, will have an adverse impact on ambient ozone air quality not greater than a vehicle operating on methanol.

(c) Operates exclusively on gasoline and is certified to meet a hydrocarbon exhaust emission standard which is at least twice as stringent as otherwise applicable to gasoline vehicles of the same year and class.

(d) Is capable, in the case of a heavy-duty diesel vehicle, of meeting standards for either oxides of nitrogen or particulate matter that are twice as stringent as otherwise applicable.

(e) This section shall become operative five years from the date determined pursuant to Section 32 of the act adding this section.

Added Stats 1994 ch 1192 § 16.5 (SB 2050), operative date contingent.

**Note**—Stats 1994 ch 1192 provides:

SEC. 32. (a) This act, except Section 29, shall not become operative until both of the following occur:

(1) The system required by subdivision (b) of Section 44060 of the Health and Safety Code for the electronic filing of certificates of compliance or noncompliance is determined to be operational by the Department of Consumer Affairs and that fact is reported by the department to the Secretary of State.

(2) The San Diego County Air Pollution Control District and the Ventura County Air Pollution Control District have sufficient funds available to implement the pilot program established pursuant to subdivision (b) of Section 43705 of the Health and Safety Code, as determined by each of those districts and reported by each district to the Secretary of State.

(b) On the date that all of the reports have been received by the Secretary of State pursuant to subdivision (a), subject to the exceptions stated in Section 33 of this act, this act shall be operative.

**§ 43801. Legislative finding and declaration**

The Legislature finds and declares that emission of air pollutants from motor vehicles is a major contributor to air pollution within the State of California and, therefore, declares its policy to encourage the development and testing of various types of low-emission motor vehicles, which would contribute substantially to achieving a pure and healthy atmosphere for the people of this state.

Added Stats 1975 ch 957 § 12.

**§ 43802. Identification and labeling of low-emission motor vehicles; Exemptions from sales and use taxes**

(a) At the time of certification pursuant to Article 1 (commencing with Section 43100) of Chapter 2 of this part, the state board shall identify those motor vehicles which qualify as low-emission vehicles as defined in Section 39037.05. As part of the identification process, the state board shall require qualifying vehicles to be clearly labeled as low-emission vehicles. Labeling shall include a statement of the incremental cost, determined pursuant to Section 43804.3, exempted from sales and use tax pursuant to subdivision (a) of Section 6356.5 of

the Revenue and Taxation Code. For motor vehicles identified as low-emission motor vehicles by the board, the standards specified in Section 39037.05 shall be the applicable emission standards for Chapter 2 (commencing with Section 43100) of this part. No later than October 1, 1990, and at least annually thereafter, the state board shall submit a listing of certified low-emission motor vehicles to the Department of General Services. Certification determinations for all vehicle and fuel types shall be based solely on vehicle emissions and shall not be based on emissions from the production, compressing, refining, or transportation of fuel.

(b) Each time a resolution is granted pursuant to Section 27156 of the Vehicle Code, the state board shall identify those motor vehicle control devices and applications which convert conventional vehicles into low-emission vehicles as identified in Section 39037.05. As part of the identification process, the state board shall require identified devices to be clearly labeled as such for purposes of those applications specified by the state board. Labeling shall include a statement that the device is exempt from sales and use tax pursuant to subdivision (b) of Section 6356.5 of Revenue and Taxation Code.

(c) For purposes of this section, “device” means physical equipment to be installed on a vehicle.

Added Stats 1989 ch 990 § 3, effective September 29, 1989.

**§ 43804. Purchase by state**

(a) If a low-emission motor vehicle meets the requirements of this chapter and the performance, cost, service, and maintenance requirements adopted by the Department of General Services for such motor vehicles, and if funds are appropriated for the purpose of purchasing motor vehicles, the state shall purchase, beginning with the next fiscal year, as many of such low-emission motor vehicles as the Department of General Services determines are reasonable and available to meet state needs.

(b) If a sufficient number of low-emission motor vehicles are available, the percentage of all such motor vehicles to be purchased in that year shall not be less than 25 percent of all motor vehicles purchased by the state in the preceding fiscal year. In purchasing vehicles pursuant to this section, the state shall seek to acquire a mix of least polluting and least cost qualifying low-emission motor vehicles.

Added Stats 1975 ch 957 § 12. Amended Stats 1989 ch 796 § 5.

**ARTICLE 4**

**Alcohol Fueled Motor Vehicles**

Section  
43843. Methanol-gasoline experimental vehicle fleet program

**§ 43843. Methanol-gasoline experimental vehicle fleet program**

(a) The state board, in consultation with the State Energy Resources Conservation and Development Commission, shall establish and conduct, until January 1, 1988, an experimental program in which fleet vehicles may utilize gasoline into which methanol has been blended.

(b) In order to participate in the methanol-gasoline experimental vehicle fleet program, all of the following

information shall be submitted to the state board for each vehicle proposed for participation in the program:

(1) The make, model, vehicle identification number, and license number of each vehicle.

(2) A description of the fuel to be used in the vehicle.

(3) Evidence that the vehicle's emissions using the methanol-gasoline blend will be no higher than the vehicle's emissions using gasoline which complies with the volatility standard established pursuant to Section 43830. Evidence may be based on emission tests or a combination of emission tests and engineering evaluation.

(4) A description of any modifications to the vehicle necessary to comply with paragraph (3).

(5) A valid certificate of compliance issued pursuant to Section 4000.1, 4000.2, or 4000.3 of the Vehicle Code.

(c) Within 60 days of receipt of a request to participate in the program, the state board, in consultation with the State Energy Resources Conservation and Development Commission, shall approve or deny the request. Approval shall be granted if adequate evidence is provided that use of the fuel will not cause or contribute to an increase in vehicle emissions when using the methanol-gasoline blend.

(d) The state board may periodically test vehicles enrolled in the program for compliance. Failure to meet state emission standards shall not result in imposition of any fine or penalty if there are no violations of Section 27156 of the Vehicle Code, and the vehicle is restored to conform to applicable emission standards at the end of the experimental program.

(e) All of the following records shall be maintained on each vehicle and shall be made available to the state board upon request:

(1) Fuel economy.

(2) Maintenance and repair.

(3) Driveability.

(f) The state board may exempt the vehicles in any fleet participating in the program from the requirements of subdivision (b) until July 1, 1985. The exemption shall be granted if the applicant demonstrates that the evidence required pursuant to paragraph (3) of subdivision (b) is not available, that there is likelihood that it will become available within the exemption period, and that the facility at which the fleet vehicle is normally refueled does not have provisions for the distribution of more than one type of fuel.

Added Stats 1984 ch 1278 § 2.

## CHAPTER 5

### Motor Vehicle Inspection Program

#### ARTICLE 1

##### General

###### Section

44000. Legislative declaration of intent

44000.1. Legislative intent

44000.5. Intent

44001. Legislative findings and declarations

44001.1. Legislative findings and declarations; Legislative intent

44001.3. Legislative findings and declarations

44001.5. Duties of Bureau of Automotive Repair

###### Section

44002. Authority of department and employees; Requirements governing inspections and repairs

44003. Enhanced vehicle inspection and maintenance program; Procedures and equipment; Requests for implementation

44003.5. Enhanced Motor Vehicle Inspection and Maintenance program Established

44004. Program to supersede other programs; Inapplicability of provisions

44005. Components of program; Frequency of inspection

#### § 44000. Legislative declaration of intent

By the enactment of the 1994 amendments to this chapter made pursuant to the act that added this section, the Legislature hereby declares its intent to meet or exceed the air quality standards established by the amendments enacted to the federal Clean Air Act in 1990 (42 U.S.C. Sec. 7401 et seq., as amended by P.L. 101-549), to enhance and improve the existing vehicle inspection and maintenance network, and to periodically monitor the performance of the network against stated objectives.

Added Stats 1994 ch 27 § 4 (AB 2018), effective March 30, 1994.

#### § 44000.1. Legislative intent

It is the intent of the Legislature that the amendments made to this part by the act that added this section during the 1999-2000 Regular Session not negatively affect the ability of the state to achieve its emission reduction goals.

Added Stats 1999 ch 67 § 12 (AB 1105), effective July 6, 1999.

#### § 44000.5. Intent

(a) The Legislature further finds and declares that the motor vehicle inspection and maintenance program implemented under this chapter has, since 1984, provided beneficial emission reductions without undue inconvenience to California vehicle owners, and vehicle owners will benefit from the maintenance by the state of a substantially decentralized program giving them a choice among thousands of independent licensed stations able to perform both inspection and repair of vehicles.

(b) With the enactment of this chapter, the Legislature does not intend to create a statutory presumption that any motor vehicle, solely by virtue of make, model, or year of manufacture, shall be classified or categorized as a "gross polluter" or a "gross polluting vehicle."

(c)(1) With the enactment of this chapter, the Legislature does not intend to place an unreasonable burden on fleet vehicles with respect to compliance with smog inspection and maintenance regulations.

(2) Fleet vehicles shall not be included in the certification requirements established pursuant to Section 44014.7.

Added Stats 1996 ch 1088 § 1 (AB 2515), effective September 30, 1996.

#### § 44001. Legislative findings and declarations

(a) The Legislature hereby finds and declares that California has been required, by the amendments enacted to the Clean Air Act in 1990, and by regulations adopted by the Environmental Protection Agency, to enhance California's existing motor vehicle inspection and maintenance program to meet new, more stringent emission reduction targets. Therefore, the Legislature declares that the 1994 amendments to this chapter are

adopted to implement further improvements in the existing inspection and maintenance program so that California will meet or exceed the new emission reduction targets.

(b) The Legislature further finds and declares all of the following:

(1) California is recognized as a leader in establishing performance standards for its air quality programs and those standards have been adopted by many other states and countries.

(2) Studies show that a minority of motor vehicles produce a disproportionate amount of the pollution caused by vehicle emissions. Those vehicles are referred to as gross polluters.

(3) The concept of periodic testing alone does not act as a sufficient deterrent to tampering, or as a sufficient incentive for vigilant vehicle maintenance by a significant percentage of motorists. Gross polluters continue to be driven on the roadways of California.

(4)(A) New technology, known as remote sensing, offers great promise as a cost-effective means to detect vehicles emitting excess emissions as the vehicles are being driven. This type of detection offers many valuable applications, especially its use between scheduled tests, as an inexpensive, random, and pervasive means of identifying vehicles which are gross polluters and targeting those vehicles for repair or other methods of emission reduction.

(B) Another new technology, the development of emissions profiles for motor vehicles, allows the motor vehicle inspection program to accurately identify both high- and low-emitting vehicles. This technology may allow the full or partial exception of certain vehicles from biennial certification requirements to the extent determined by the department.

(5) California continues to seek strict adherence to federal and state performance standards and to results-based evaluations that meet the state's unique circumstances, and which consist of all of the following:

(A) Acceptance of the shared obligation and personal responsibility required to successfully inspect and maintain millions of motor vehicles. Specifically, that obligation begins with this chapter, and extends through those regulators charged with its implementation and enforcement. Through the enactment of the 1994 amendments to this chapter, the Legislature hereby recognizes and seeks to encourage, through a number of innovative and significant steps, the critical role that each California motorist must play in maintaining his or her vehicle's emission control systems in proper working order, in such a way as to continuously meet mandated emission control standards and ensure for California the clean air essential to the health of its citizens, its communities, and its economy.

(B) A focus on the detection, diagnosis, and repair of broken, tampered, or malfunctioning vehicle emission control systems.

(C) Flexibility to incorporate and implement future new scientific findings and technological advances.

(D) Consideration of convenience and costs to those who are required to participate, including motorists, smog check stations, and technicians.

(E) An enforcement program which is vigorous and effective and includes monitoring of the performance of

the smog check test or repair stations and technicians, as well as the monitoring of vehicle emissions as vehicles are being driven.

(c) The Legislature further finds and declares that California is, as of the effective date of this section, implementing a number of motor vehicle emission reduction strategies far beyond the effort undertaken by any other state, including all of the following:

(1) California certification standards exceed those of the other 49 states, increasing the cost of a new car to a California consumer by one hundred fifty dollars (\$150) or more.

(2) State board regulations mandate increasing availability for sale of low-emission, ultra-low emission, and zero-emission vehicles, including, by 2003, 10 percent zero-emission vehicles.

(3) Effective in 1996, state board regulations mandate the reformulation of gasoline for reduced emissions, at an estimated increased production cost of 5 to 15 cents per gallon due to refinery modifications and higher production costs.

(4) Cleaner diesel fuel regulations, more stringent than federal standards, took effect in California in October 1993, increasing diesel fuel costs by 4 to 6 cents per gallon.

(5) California law provides for vehicle registration surcharges of up to four dollars (\$4) per vehicle in nonattainment areas for air quality-related projects.

(6) California law taxes cleaner fuels at one-half the rate of gasoline and diesel fuel.

(7) California law provides tax credits for the purchase of low-emission vehicles.

(8) California requires smog checks and repairs whenever a vehicle changes ownership, some 3 million vehicles annually, in addition to the regular biennial tests.

(9) Low-value vehicles are discouraged from entering California due to the imposition of a three hundred dollar (\$300) smog impact fee on vehicles that are not manufactured to California certification standards.

(10) California imposes sales taxes on motor vehicle fuels and dedicates most of those revenues to mass transit. This increases the cost of fuels by seven cents (\$.07) per gallon.

(11) Transportation sales taxes in most urban counties also generate substantial funding for transit and other congestion-reduction measures, costing the average urban California resident fifty dollars (\$50) to one hundred dollars (\$100) annually, which would be the equivalent of another 8 to 16 cents per gallon of fuel.

Added Stats 1994 ch 27 § 6, effective March 30, 1994. Amended Stats 1997 ch 803 § 3 (AB 1492).

#### § 44001.1. Legislative findings and declarations; Legislative intent

(a) The Legislature finds and declares that additional reductions of motor vehicle emissions could be achieved by effective repairs to motor vehicle emission control components.

(b) It is the intent of the Legislature that the department work with the California Community Colleges and other training institutions to identify funding mechanisms that encourage the development of innovative training programs for motor vehicle technicians that focus on reducing air pollution from vehicles needing

repair and to increase the number and skill level of motor vehicle technicians.

Added Stats 2010 ch 258 § 1 (AB 2289), effective January 1, 2011.

**§ 44001.3. Legislative findings and declarations**

The Legislature hereby finds and declares as follows:

(a) Under the state's previous smog check program, a motor vehicle owner could obtain unlimited repair cost waivers and, therefore, avoid repair of a polluting vehicle.

(b) As a result, many vehicles were reregistered year after year and allowed to continue to pollute the air.

(c) Repairing high-polluting and gross polluting vehicles (which pollute 2 to 25 times more than the average vehicle that passes a smog check) could significantly improve California air quality and allow the state to meet federal clean air goals.

(d) The existing repair cost limit for smog repairs is a minimum of four hundred fifty dollars (\$450) in all areas where the enhanced smog check program operates; fifty dollars (\$50) to three hundred dollars (\$300) based on the model year of the vehicle where the enhanced program is not fully implemented; and no cost limit for the repair of gross polluting vehicles.

(e) Without state financial assistance to repair a vehicle, a low-income vehicle owner is forced to either scrap the vehicle or drive an unregistered vehicle.

Added Stats 1997 ch 804 § 1 (AB 57).

**§ 44001.5. Duties of Bureau of Automotive Repair**

(a) A duty of enforcing and administering this chapter is vested in the chief of the bureau who is responsible to the director.

(b) The department shall take those actions consistent with its statutory authority to ensure that the reduction in vehicle emissions of hydrocarbons, carbon monoxide, and oxides of nitrogen meet or exceed the reductions required by the amendments enacted to the Clean Air Act in 1990. The department shall endeavor to achieve these vehicle emission reductions as expeditiously as practicable, but not later than the deadlines established by the amendments enacted to the Clean Air Act in 1990.

(c) The department shall also ensure that gross polluters are identified and failed when tested pursuant to this chapter and that vehicles meeting the state standards are protected from being falsely failed.

(d) The department may exercise the emergency rule-making powers in Chapter 3.5 (commencing with Section 11340) of Part 1 of Division 3 of Title 2 of the Government Code in order to promptly issue any regulations required to implement the 1994 amendments to this chapter.

Added Stats 1988 ch 1544 § 19. Amended Stats 1989 ch 1154 § 5; Stats 1994 ch 27 § 7 (AB 2018), effective March 30, 1994; Stats 1995 ch 91 § 90 (SB 975).

**§ 44002. Authority of department and employees; Requirements governing inspections and repairs**

The department shall have the sole and exclusive authority within the state for developing and implementing the motor vehicle inspection program in accordance with this chapter.

For the purposes of administration and enforcement of this chapter, the department, and the director and offi-

cers and employees thereof, shall have all the powers and authority granted under Division 1 (commencing with Section 1) and Division 1.5 (commencing with Section 475) and Chapter 20.3 (commencing with Section 9880) of Division 3 of the Business and Professions Code and under Chapter 33 (commencing with Section 3300) of Title 16 of the California Code of Regulations. Inspections and repairs performed pursuant to this chapter, in addition to meeting the specific requirements imposed by this chapter, shall also comply with all requirements imposed pursuant to Division 1 (commencing with Section 1) and Division 1.5 (commencing with Section 475) and Chapter 20.3 (commencing with Section 9880) of Division 3 of the Business and Professions Code and Chapter 33 (commencing with Section 3300) of Title 16 of the California Code of Regulations.

Added Stats 1982 ch 892 § 2. Amended Stats 1990 ch 1433 § 14 (SB 1874).

**§ 44003. Enhanced vehicle inspection and maintenance program; Procedures and equipment; Requests for implementation**

(a)(1) An enhanced motor vehicle inspection and maintenance program is established in each urbanized area of the state, any part of which is classified by the Environmental Protection Agency as a serious, severe, or extreme nonattainment area for ozone or a moderate or serious nonattainment area for carbon monoxide with a design value greater than 12.7 ppm, and in other areas of the state as provided in this chapter.

(2) A basic vehicle inspection and maintenance program shall be continued in all other areas of the state where a program was in existence under this chapter as of the effective date of this paragraph.

(b) The department may prescribe different test procedures and equipment requirements for those areas described in subdivision (a). Program components shall be operated in all program areas unless otherwise indicated, as determined by the department. In those areas where the biennial program is not implemented and smog check inspections are required to complete the requirements set forth in Sections 4000.1 and 4000.2 of the Vehicle Code, program elements that apply in basic areas, including test equipment requirements for smog check stations, shall apply.

(c)(1) Districts classified as attainment areas may request the department to implement all or part of the program elements defined in this chapter. However, the department shall not implement the program established by Section 44010.5 in any area other than an urbanized area, any part of which is classified by the Environmental Protection Agency as a serious, severe, or extreme nonattainment area for ozone or a moderate or serious nonattainment area for carbon monoxide with a design value greater than 12.7 ppm.

(2) Districts that include areas classified as basic program nonattainment areas pursuant to subdivision (a) may, except as provided in paragraph (1), request the implementation in those areas of test procedures and equipment required for enhanced program areas and any other program requirement specified for enhanced program areas.

Added Stats 1988 ch 1544 § 21. Amended Stats 1989 ch 1154 § 6; Stats 1994 ch 27 § 8 (AB 2018), effective March 30, 1994; Stats 1997 ch 802 § 2

(AB 208); Stats 2001 ch 745 § 137 (SB 1191), effective October 12, 2001; Stats 2012 ch 728 § 91 (SB 71), effective January 1, 2013.

**§ 44003.5. Enhanced Motor Vehicle Inspection and Maintenance program Established**

(a) Notwithstanding any other provision of law, an enhanced motor vehicle inspection and maintenance program, including the provisions of the test-only program described in Section 44010.5, is established in the San Francisco Bay Area Basin, consistent with the requirements described in subdivision (b).

(b) The department shall commence operation of the enhanced motor vehicle inspection and maintenance program in the urbanized areas of the San Francisco Bay Area Basin, including directing motor vehicles to test-only facilities, after the department determines that an adequate number of test-only stations, test and repair stations, referee services, and other facilities and equipment necessary to provide reliable and convenient service to vehicle owners subject to the program exist in that basin.

(c) Upon commencing operation of the enhanced program in those areas of the San Francisco Bay Area Basin subject to the requirements of the program, the bureau shall utilize emission standards for oxides of nitrogen, and percentages of vehicles directed to test-only stations similar to those utilized to begin the initial implementation of the program in other enhanced areas of the state. The department shall phase-in more stringent emission standards for oxides of nitrogen and direct higher percentages of vehicles to test-only stations, so that the fully implemented enhanced program in the San Francisco Bay area is consistent with the fully implemented enhanced program in other areas of the state.

(d)(1) On or before January 1, 2004, and concurrent with implementing subdivision (b), the board shall submit for peer review the study produced by the University of California at Riverside and commissioned by the Bay Area Air Quality Management District, and any other available scientifically credible evidence, to determine the impact of the enhanced motor vehicle inspection and maintenance program on Contra Costa County and surrounding areas. If the peer review concludes that the enhanced motor vehicle inspection and maintenance program in the urbanized areas of the San Francisco Bay Area Basin results in adverse ozone and other air quality impacts in Contra Costa County or parts of Solano, San Joaquin, Alameda, and Santa Clara Counties, the board, on or before January 1, 2004, shall suggest mitigation measures to the Legislature and to the respective air quality districts. These measures may include, but need not be limited to, a recommendation for additional funds to be made available for transit purposes and private passenger motor vehicle maintenance and repair purposes.

(2) It is the intent of the Legislature in enacting this section to seek implementation of those mitigation measures suggested under paragraph (1) that are found to be scientifically credible means to mitigate adverse ozone and other air quality impacts, are consistent with this section, and do not adversely impact downwind regions.

(e) Consistent with subdivision (b), it is the intent of the Legislature that the department commence operation of the enhanced motor vehicle inspection and main-

tenance program in the urbanized areas of the San Francisco Bay Air Basin as expeditiously as possible in order to assist the San Francisco Bay Area and downwind air districts in meeting their federal air quality attainment requirements.

Added Stats 2002 ch 1001 § 2 (AB 2637).

**§ 44004. Program to supersede other programs; Inapplicability of provisions**

(a) The motor vehicle inspection program provided by this chapter, when implemented in a district, shall supersede and replace any other program for motor vehicle emission inspection in the district.

However, this chapter shall not apply to any vehicle permanently located on an island in the Pacific Ocean located 20 miles or more from the mainland coast.

(b) The motor vehicle inspection program provided by this chapter shall be in accordance with Sections 4000.1, 4000.2, and 4000.3 of the Vehicle Code.

Added Stats 1982 ch 892 § 2.

**§ 44005. Components of program; Frequency of inspection**

(a) The Department of Motor Vehicles shall cooperate with the department in implementing any changes to enhance the program to achieve greater efficiency, cost effectiveness, and convenience, or to reduce excess emissions in accordance with this chapter.

(b) The program shall provide for inspection of specified motor vehicles, as determined by the department, upon initial registration, biennially upon renewal of registration, upon transfer of ownership, upon the issuance of a notice of noncompliance to a gross polluter pursuant to Section 44081, and as otherwise provided in this chapter.

Added Stats 1982 ch 892 § 2. Amended Stats 1994 ch 27 § 11 (AB 2018), effective March 30, 1994, ch 1220 § 12 (AB 3132), effective September 30, 1994; Stats 1997 ch 803 § 4 (AB 1492).

**ARTICLE 2**

**Program Requirements**

- Section
- 44010. Provisions for smog check stations
- 44010.5. Program for testing specified percentage of state vehicle fleet at test-only facilities; Testing at smog check stations; Contractors; Public education; Implementation areas
- 44011. Certificate of compliance or noncompliance; Exceptions
- 44011.1. "Registered"
- 44011.3. Pretesting
- 44011.5. Proof of exemption requirements
- 44011.6. Test for smoke emissions; Advisory committee; Regulation and inspection; Criteria for compliance; Penalties; Administrative hearing
- 44012. Tests required at smog check stations
- 44012.1. Visible smoke test
- 44013. (First of three; Operative date contingent) Prescription of maximum emission standards and test procedures
- 44013. (Second of three; Operative date contingent; Operative term contingent) Prescription of maximum emission standards and test procedures
- 44013. (Third of three; Operative date contingent) Prescription of maximum emission standards and test procedures
- 44013.5. (Operative date contingent; Operative term contingent) Certification of emissions retrofit device installations
- 44014. Smog check stations and technicians; Licensing and qualifications; Provision for referee services; Fees
- 44014.2. Certification program

## Section

- 44014.4. Advertisement
- 44014.5. Test-only facilities; Standards
- 44014.6. Inspection-based performance standards; Criteria; Applicability
- 44014.7. Required receipt of certificate from test-only station
- 44015. Certification of certain vehicles prohibited; Issuance of certificates; Repair cost waivers; Economic hardship extensions; Responsibility of licensed motor vehicle dealers
- 44015.5. Certificate of compliance; Certificate of noncompliance
- 44016. Specifications and procedures
- 44017. Cost limitations; Repair cost waiver; Failure to pass visible smoke test
  - 44017.1. "Low-income motor vehicle owner"; Repair cost limit; Issuance of economic hardship extension
  - 44017.3. Information required to be posted at smog check stations
  - 44017.4. Inspection of specially constructed vehicles
  - 44017.5. Alternative work day schedule at referee stations
- 44018. Advisory safety and fuel efficiency checks; Exemptions
- 44019. Certificates of compliance for public agency vehicles
- 44020. Testing and servicing of fleet vehicles by fleet owner; Conditions; Initial and renewal license fees
- 44024. New technologies
  - 44024.5. Statistical and emissions profiles and data of vehicles; Report; Pilot program to exempt vehicles from biennial certification requirement
- 44025. Department as vendor clearinghouse

#### § 44010. Provisions for smog check stations

The motor vehicle inspection program shall provide for privately operated stations which shall be referred to as smog check stations and are authorized pursuant to Section 44015 to issue certificates of compliance or noncompliance to vehicles which meet the requirements of this chapter.

Added Stats 1982 ch 892 § 2. Amended Stats 1983 ch 456 § 1; Stats 1988 ch 1544 § 23; Stats 1994 ch 27 § 12 (AB 2018), effective March 30, 1994.

#### § 44010.5. Program for testing specified percentage of state vehicle fleet at test-only facilities; Testing at smog check stations; Contractors; Public education; Implementation areas

(a) The department shall implement a program with the capacity to commence, by January 1, 1995, the testing at test-only facilities, in accordance with this chapter, of 15 percent of that portion of the total state vehicle fleet consisting of vehicles subject to inspection each year in the biennial program and that are registered in the enhanced program area, as established pursuant to paragraph (1) of subdivision (a) of Section 44003.

(b)(1) The department shall increase the capacity of the program so that the capacity exists to commence, by January 1, 1996, the testing at test-only facilities of that portion of the state vehicle fleet that is subject to inspection and is registered in the enhanced program area, which is sufficient to meet the emission reduction performance standards established by the United States Environmental Protection Agency in regulations adopted pursuant to the Clean Air Act Amendments of 1990, taking into account the results of the pilot demonstration program established pursuant to Section 44081.6.

(2) Upon increasing the capacity of the program pursuant to paragraph (1), the department shall afford smog check stations that are licensed and certified pursuant to Sections 44014 and 44014.2 the initial opportunity to perform the required inspections. The department shall adopt, by regulation, the requirements to provide that initial opportunity.

(3) If the department determines that there is an insufficient number of licensed test-only smog check stations operating in an enhanced area to meet the increased demand for test-only inspections, the department may increase the capacity of the program by utilizing existing contracts.

(c) The program shall utilize the testing procedures described in Section 44012. Vehicles selected for testing pursuant to this section shall include vehicles equipped without second generation onboard diagnostic systems (OBD II) and vehicles with emission problems that may not be adequately detected by the vehicle's OBD II, as determined by the department in consultation with the state board. The department, in consultation with the state board, may also select for testing pursuant to this section any other vehicles necessary in order to meet the requirement described in paragraph (1) of subdivision (b).

(d) Vehicles that are not diesel-powered in the enhanced program area which are not subjected to the program established by this section may be tested at smog check stations licensed pursuant to Section 44014 that use loaded mode dynamometers. Diesel-powered vehicles in the enhanced program area that are not subjected to the program established by this section may be tested at smog check stations licensed pursuant to Section 44014 using appropriate testing procedures as determined by the department.

(e)(1) The department may implement the program established pursuant to subdivision (a) through a network of privately operated test-only facilities established pursuant to contracts to be awarded pursuant to this section.

(2) The initial contracts awarded pursuant to this section shall terminate not later than seven years from the date that the contracts were executed.

(f) No person shall be a contractor of the department for test-only facilities in all air basins, exclusively, where the enhanced program is in effect unless the department determines, after a public hearing, that there is not more than one qualified contractor. The South Coast Air Basin shall have at least two contractors, and the combined enhanced program area that includes Bakersfield, Fresno, and Sacramento shall have at least two contractors. The department may operate test-only facilities on an interim basis while contractors are being sought.

(g)(1) In awarding contracts under this section, the department shall request bids through the issuance of a request for proposal.

(2) The department shall first determine which bidders are qualified, and then award the contract to the qualified bidder, giving priority to the test cost and convenience to motorists.

(3) The department shall provide a contractual preference, as determined by the department, not to exceed 10 percent of the total proposal evaluation score, based on the following factors:

(A) Up to 5 percent to bidders providing firm commitments to employ businesses that are licensed or otherwise substantially participating in the smog check program after January 1, 1994.

(B) Up to 5 percent to bidders based on the extent to which bidders maximize the potential economic benefit of the smog check program on this state over the term of

the contract. That potential economic benefit shall include the percentage of work performed by California-based firms, the potential of the total project workforce who will be California residents, and the percentage of subcontracts that will be awarded to California-based firms.

(4) Any contract executed by the department for the operation of a test-only facility shall expressly require compliance with this chapter and any regulations adopted by the department pursuant to this chapter.

(h) The department shall ensure that there is a sufficient number of test-only facilities, and that they are properly located, to ensure reasonable accessibility and convenience to all persons within an enhanced program area, and that the waiting time for consumers is minimized. The department may operate test-only facilities on an interim basis to ensure convenience to consumers. The department shall specify in the request for proposal the minimum number of test-only facilities that are required for the program. Any contracts initially awarded pursuant to this section shall ensure that the contractors are capable of fulfilling the requirements of subdivision (a).

(i) Any data generated at a test-only facility shall be the property of the state, and shall be fully accessible to the department at any time. The department may set contract specifications for the storage of that data in a central data storage system or facility designated by the department.

(j) The department shall ensure an effective transition to the new program by implementing an effective public education program and may specify in the request for proposal a dollar amount that bidders are required to include in their bids for public education activities, to be implemented pursuant to Section 44070.5.

(k) The department shall ensure the effective management of the test-only facilities and shall specify in the request for proposal that a manager be present during all hours of station operation.

(l) The department shall ensure and facilitate the effective transition of employees of businesses that are licensed or otherwise substantially participating in the smog check program and may specify in the request for proposal that test-only facility management be Automotive Service Excellence (ASE) certified, or be certified by a comparable program as determined by the department.

(m) As part of the contracts to be awarded pursuant to subdivision (e), the department may require contractors to perform functions previously undertaken by referee stations throughout the state, as determined by the department, at some or all of the affected stations in enhanced areas, and at additional stations outside enhanced areas only to the extent necessary to provide appropriate access to referee functions.

(n) Notwithstanding any other provision of law, to avoid delays to the program implementation timeline required by this chapter or the Clean Air Act, the Department of General Services, at the request of the department, may exempt contracts awarded pursuant to this section from existing laws, rules, resolutions, or procedures that are otherwise applicable, including, but not limited to, restrictions on awarding contracts for more than three years. The department shall identify

any exemptions requested and granted pursuant to this subdivision and report thereon to the Legislature.

(o) The department shall implement the program established in this section only in urbanized areas classified by the United States Environmental Protection Agency as a serious, severe, or extreme nonattainment area for ozone or a moderate or serious nonattainment area for carbon monoxide with a design value greater than 12.7 ppm, and shall not implement the program in any other area.

Added Stats 1994 ch 29 § 1 (SB 521), effective March 30, 1994. Amended Stats 1996 ch 1088 § 2 (AB 2515), effective September 30, 1996; Stats 2007 ch 739 § 1 (AB 1488), effective January 1, 2008; Stats 2010 ch 258 § 2 (AB 2289), effective January 1, 2011.

#### § 44011. Certificate of compliance or noncompliance; Exceptions

(a) All motor vehicles powered by internal combustion engines that are registered within an area designated for program coverage shall be required biennially to obtain a certificate of compliance or noncompliance, except for the following:

(1) All motorcycles until the department, pursuant to Section 44012, implements test procedures applicable to motorcycles.

(2) All motor vehicles that have been issued a certificate of compliance or noncompliance or a repair cost waiver upon a change of ownership or initial registration in this state during the preceding six months.

(3) All motor vehicles manufactured prior to the 1976 model-year.

(4)(A) Except as provided in subparagraph (B), all motor vehicles four or less model-years old.

(B) Beginning January 1, 2005, all motor vehicles six or less model-years old, unless the state board finds that providing an exception for these vehicles will prohibit the state from meeting the requirements of Section 176(c) of the federal Clean Air Act (42 U.S.C. Sec. 7401 et seq.) or the state's commitments with respect to the state implementation plan required by the federal Clean Air Act.

(C) All motor vehicles excepted by this paragraph shall be subject to testing and to certification requirements as determined by the department, if any of the following apply:

(i) The department determines through remote sensing activities or other means that there is a substantial probability that the vehicle has a tampered emission control system or would fail for other cause a smog check test as specified in Section 44012.

(ii) The vehicle was previously registered outside this state and is undergoing initial registration in this state.

(iii) The vehicle is being registered as a specially constructed vehicle.

(iv) The vehicle has been selected for testing pursuant to Section 44014.7 or any other provision of this chapter authorizing out-of-cycle testing.

(D) This paragraph does not apply to diesel-powered vehicles.

(5) In addition to the vehicles exempted pursuant to paragraph (4), any motor vehicle or class of motor vehicles exempted pursuant to subdivision (c) of Section 44024.5. It is the intent of the Legislature that the department, pursuant to the authority granted by this



paragraph, exempt at least 15 percent of the lowest emitting motor vehicles from the biennial smog check inspection.

(6) All motor vehicles that the department determines would present prohibitive inspection or repair problems.

(7) Any vehicle registered to the owner of a fleet licensed pursuant to Section 44020 if the vehicle is garaged exclusively outside the area included in program coverage, and is not primarily operated inside the area included in program coverage.

(8)(A) All diesel-powered vehicles manufactured prior to the 1998 model-year.

(B) All diesel-powered vehicles that have a gross vehicle weight rating of 8,501 to 10,000 pounds, inclusive, until the department, in consultation with the state board, pursuant to Section 44012, implements test procedures applicable to these vehicles.

(C) All diesel-powered vehicles that have a gross vehicle weight rating from 10,001 pounds to 14,000 pounds, inclusive, until the state board and the Department of Motor Vehicles determine the best method for identifying these vehicles, and until the department, in consultation with the state board, pursuant to Section 44012, implements test procedures applicable to these vehicles.

(D) All diesel-powered vehicles that have a gross vehicle weight rating of 14,001 pounds or greater.

(b) Vehicles designated for program coverage in enhanced areas shall be required to obtain inspections from appropriate smog check stations operating in enhanced areas.

(c) For purposes of subdivision (a), a collector motor vehicle, as defined in Section 259 of the Vehicle Code, is exempt from those portions of the test required by subdivision (f) of Section 44012 if the collector motor vehicle meets all of the following criteria:

(1) Submission of proof that the motor vehicle is insured as a collector motor vehicle, as shall be required by regulation of the bureau.

(2) The motor vehicle is at least 35 model-years old.

(3) The motor vehicle complies with the exhaust emissions standards for that motor vehicle's class and model-year as prescribed by the department, and the motor vehicle passes a functional inspection of the fuel cap and a visual inspection for liquid fuel leaks.

Added Stats 2007 ch 739 § 3 (AB 1488), effective January 1, 2008, operative January 1, 2010. Amended Stats 2009 ch 200 § 3 (SB 734), effective January 1, 2010, operative January 1, 2010; Stats 2013 ch 319 § 16 (SB 822), effective January 1, 2014.

#### § 44011.1. "Registered"

For purposes of Section 44011, the term "registered within an area designated for program coverage" includes any vehicle registered pursuant to the Vehicle Code in this state when the registered owner's mailing or residence address is not located within this state, or when the address at which the vehicle is garaged is not located within this state.

Added Stats 1993 ch 633 § 1 (AB 2008).

#### § 44011.3. Pretesting

Every motor vehicle that is subject to testing pursuant to this chapter may be pretested. As used in this section, a pretest is a smog inspection in which the motor vehicle

is submitted to some or all of the required elements of the emissions inspection as specified in Section 44012, the results of which will not be reported to the Department of Motor Vehicles and for which a certificate will not be issued. A person choosing to have his or her vehicle pretested has the right to have a complete pretest of the vehicle unless the person requests a partial pretest. If the person requests a partial pretest, the licensed technician or an authorized representative of the licensed smog check station shall inform the vehicle owner that the partial pretest may not indicate the likelihood of the vehicle passing a subsequent official inspection.

Added Stats 1998 ch 938 § 1 (SB 1754).

#### § 44011.5. Proof of exemption requirements

Documentation that a motor vehicle is exempt from the requirements of Section 44011 may not be based solely on the owner's statement that the vehicle is in an exempt category. Physical inspection of the vehicle by the department is required unless alternative documentation satisfactory to the department is available.

Added Stats 1988 ch 1544 § 25.

#### § 44011.6. Test for smoke emissions; Advisory committee; Regulation and inspection; Criteria for compliance; Penalties; Administrative hearing

(a) The use of a heavy-duty motor vehicle that emits excessive smoke is prohibited.

(b)(1) As expeditiously as possible, the state board shall develop a test procedure for the detection of excessive smoke emissions from heavy-duty diesel motor vehicles that is feasible for use in an intermittent roadside inspection program. During the development of the test procedure, the state board shall cooperate with the Department of the California Highway Patrol in conducting roadside inspections.

(2) The state board may also specify visual or functional inspection procedures to determine the presence of tampering or defective emissions control systems in heavy-duty diesel or heavy-duty gasoline motor vehicles. However, visual or functional inspection procedures for heavy-duty gasoline motor vehicles shall not be more stringent than those prescribed for heavy-duty gasoline motor vehicles subject to biennial inspection pursuant to Section 44013.

(3) The chairperson of the state board shall appoint an ad hoc advisory committee that shall include, but not be limited to, representatives of heavy-duty engine manufacturers, carriers of property for compensation using heavy-duty gasoline or heavy-duty diesel motor vehicles, and the Department of the California Highway Patrol. The advisory committee shall cooperate with the state board to develop a test procedure pursuant to this subdivision and shall advise the state board in developing regulations to implement test procedures and inspection of heavy-duty commercial motor vehicles.

(c) Any smoke testing procedures or smoke measuring equipment, including any meter that measures smoke opacity or density and any recorder that stores or records smoke opacity or density measurements, used to test for compliance with this section and regulations adopted

pursuant to this section, shall produce consistent and repeatable results. The requirements of this subdivision shall be satisfied by the adoption of Society of Automotive Engineers recommended practice J 1667, "Snap-Acceleration Smoke Test Procedures for Heavy-Duty Diesel Powered Vehicles."

(d)(1) The smoke test standards and procedures adopted and implemented pursuant to this section shall be designed to ensure that no engine will fail the smoke test standards and procedures when the engine is in good operating condition and is adjusted to the manufacturer's specifications.

(2) In implementing this section, the state board shall adopt regulations that ensure that there will be no false failures or that ensure that the state board will remedy any false failures without any penalty to the vehicle owner.

(e) The state board shall enforce the prohibition against the use of heavy-duty motor vehicles that are determined to have excessive smoke emissions and shall enforce any regulation prohibiting the use of a heavy-duty motor vehicle determined to have other emissions-related defects, using the test procedure established pursuant to this section.

(f) The state board may issue a citation to the owner or operator for any vehicle in violation of this section. The regulations may require the operator of a vehicle to submit to a test procedure adopted pursuant to subdivision (b) and this subdivision, and may specify that refusal to so submit is an admission constituting proof of a violation, and shall require that, when a citation has been issued, the owner of a vehicle in violation of the regulations shall, within 45 days, correct every deficiency specified in the citation.

(g) The department may develop criteria for one or more classes of smog check stations capable of determining compliance with regulations adopted pursuant to this section and may authorize those stations to issue certificates of compliance to vehicles in compliance with the regulations. The department may contract for the operation of smog check stations for heavy-duty motor vehicles pursuant to this subdivision, and only heavy-duty motor vehicles may be inspected at those stations.

(h) In addition to the corrective action required by this section, the owner of a motor vehicle in violation of this section is subject to a civil penalty of not more than one thousand five hundred dollars (\$1,500) per day for each day that the vehicle is in violation. The state board may adopt a schedule of reduced civil penalties to be applied in cases where violations are corrected in an expeditious manner. However, the schedule of reduced civil penalties shall not apply where there have been repeated incidents of emissions control system tampering. All civil penalties imposed pursuant to this subdivision shall be collected by the state board and deposited in the Vehicle Inspection and Repair Fund. Funds in the Vehicle Inspection and Repair Fund, when appropriated by the Legislature, shall be available to the state board and the Department of the California Highway Patrol for the conduct of intermittent roadside inspections of heavy-duty motor vehicles pursuant to this section.

(i) Following the adoption of regulations pursuant to this section, the state board may commence inspecting heavy-duty motor vehicles. With the concurrence of the

Department of the California Highway Patrol, these inspections may be conducted in conjunction with the safety and weight enforcement activities of the Department of the California Highway Patrol, or at other locations selected by the state board or the Department of the California Highway Patrol. Inspection locations may include private facilities where fleet vehicles are serviced or maintained. The state board and the Department of the California Highway Patrol may conduct these inspections either cooperatively or independently, and the state board may contract for assistance in the conduct of these inspections.

(j) The state board shall inform the Department of the California Highway Patrol whenever a vehicle owner cited pursuant to this section fails to take a required corrective action or to pay a civil penalty levied pursuant to subdivisions (h) and (k) in a timely manner. Following notice and opportunity for an administrative hearing pursuant to subdivision (n), the state board may request the Department of the California Highway Patrol to remove the vehicle from service and order the vehicle to be stored. Upon notification from the state board of payment of any civil penalties imposed under subdivision (h) and storage and related charges, the vehicle shall be released to the owner or designee. Upon release of the vehicle, the owner or designee shall correct every deficiency specified in any citation to that owner with respect to the vehicle.

(k) In addition to the corrective action required by subdivision (f), and in addition to the civil penalty imposed by subdivision (h), the owner of a motor vehicle cited by the state board pursuant to this section shall pay a civil penalty of three hundred dollars (\$300) per citation; except that this penalty shall not apply to the first citation for any schoolbus. All civil penalties imposed pursuant to this subdivision shall be collected by the state board and deposited in the Diesel Emission Reduction Fund, which fund is hereby created. Funds in the Diesel Emission Reduction Fund, when appropriated by the Legislature, shall be available to the State Energy Resources Conservation and Development Commission for research, development, and demonstration programs undertaken pursuant to Section 25617 of the Public Resources Code.

(l) The state board shall adopt regulations that afford an owner cited under this section an opportunity for an administrative hearing consistent with, but not limited to, all of the following: (1) any owner cited under this section may request an administrative hearing within 45 days following either personal receipt or certified mail receipt of the citation; (2) if the owner fails to request an administrative hearing within 45 days, the citation shall be deemed a final order and not subject to review by any court or agency; (3) if the owner requests an administrative hearing and fails to seek review by administrative mandamus pursuant to Section 1094.5 of the Code of Civil Procedure within 60 days after the mailing of the administrative hearing decision, the decision shall be deemed a final order and not subject to review by any other court or agency; and (4) the 45-day period may be extended by the administrative hearing officer for good cause.

(m) Following exhaustion of the review procedures provided for in subdivision (l), the state board may apply

to the Superior Court of Sacramento County for a judgment in the amount of the civil penalty. The application, which shall include a certified copy of the final order of the administrative hearing officer, shall constitute a sufficient showing to warrant the issuance of the judgment.

Added Stats 1988 ch 1544 § 26. Amended Stats 1989 ch 940 § 2; Stats 1990 ch 1433 § 16 (SB 1874); Stats 1993 ch 578 § 1 (AB 584); Stats 1996 ch 292 § 1 (AB 1460); Stats 2004 ch 644 § 21 (AB 2701).

#### § 44012. Tests required at smog check stations

The test at the smog check stations shall be performed in accordance with procedures prescribed by the department and may require loaded mode dynamometer testing in enhanced areas, two-speed idle testing, testing utilizing a vehicle's onboard diagnostic system, or other appropriate test procedures as determined by the department in consultation with the state board. The department shall implement testing using onboard diagnostic systems, in lieu of loaded mode dynamometer or two-speed idle testing, on model year 2000 and newer vehicles only, beginning no earlier than January 1, 2013. However, the department, in consultation with the state board, may prescribe alternative test procedures that include loaded mode dynamometer or two-speed idle testing for vehicles with onboard diagnostic systems that the department and the state board determine exhibit operational problems. The department shall ensure, as appropriate to the test method, the following:

(a) Emission control systems required by state and federal law are reducing excess emissions in accordance with the standards adopted pursuant to subdivisions (a) and (c) of Section 44013.

(b) Motor vehicles are preconditioned to ensure representative and stabilized operation of the vehicle's emission control system.

(c) For other than diesel-powered vehicles, the vehicle's exhaust emissions of hydrocarbons, carbon monoxide, carbon dioxide, and oxides of nitrogen in an idle mode or loaded mode are tested in accordance with procedures prescribed by the department. In determining how loaded mode and evaporative emissions testing shall be conducted, the department shall ensure that the emission reduction targets for the enhanced program are met.

(d) For other than diesel-powered vehicles, the vehicle's fuel evaporative system and crankcase ventilation system are tested to reduce any nonexhaust sources of volatile organic compound emissions, in accordance with procedures prescribed by the department.

(e) For diesel-powered vehicles, a visual inspection is made of emission control devices and the vehicle's exhaust emissions are tested in accordance with procedures prescribed by the department, that may include, but are not limited to, onboard diagnostic testing. The test may include testing of emissions of any or all of the pollutants specified in subdivision (c) and, upon the adoption of applicable standards, measurement of emissions of smoke or particulates, or both.

(f) A visual or functional check is made of emission control devices specified by the department, including the catalytic converter in those instances in which the department determines it to be necessary to meet the findings of Section 44001. The visual or functional check

shall be performed in accordance with procedures prescribed by the department.

(g) A determination as to whether the motor vehicle complies with the emission standards for that vehicle's class and model-year as prescribed by the department.

(h) An analysis of pass and fail rates of vehicles subject to an onboard diagnostic test and a tailpipe test to assess whether any vehicles passing their onboard diagnostic test have, or would have, failed a tailpipe test, and whether any vehicles failing their onboard diagnostic test have or would have passed a tailpipe test.

(i) The test procedures may authorize smog check stations to refuse the testing of a vehicle that would be unsafe to test, or that cannot physically be inspected, as specified by the department by regulation. The refusal to test a vehicle for those reasons shall not excuse or exempt the vehicle from compliance with all applicable requirements of this chapter.

Added Stats 2007 ch 739 § 5 (AB 1488), effective January 1, 2008, operative January 1, 2010. Amended Stats 2010 ch 258 § 3 (AB 2289), effective January 1, 2011.

#### § 44012.1. Visible smoke test

(a) The department shall incorporate a visible smoke test into the motor vehicle inspection and maintenance program by January 1, 2008. Any visible smoke from the tailpipe or crankcase of a motor vehicle during an inspection constitutes a failure. Steam from condensation by itself shall not lead to an inspection failure.

(b) If an owner of a motor vehicle disputes the failure of a visible smoke test, the owner may seek resolution of the dispute from the state-designated referee.

(c) The department, in consultation with the state board and interested parties, shall adopt regulations to implement this section. No new equipment shall be required to implement the visible smoke test.

(d) If the implementation of the visible smoke test required by subdivision (a) requires modification of the Emission Inspection System software or Vehicle Information Database, that modification shall be performed as part of the ordinary, periodic upgrade to these systems.

Added Stats 2006 ch 761 § 1 (AB 1870), effective January 1, 2007.

#### § 44013. (First of three; Operative date contingent) Prescription of maximum emission standards and test procedures

(a)(1) The department, in cooperation with the state board, shall prescribe maximum emission standards to be applied in inspecting motor vehicles under this chapter.

(2) In prescribing the standards, the department shall undertake studies and experiments which are necessary and feasible, evaluate available data, and confer with automotive engineers.

(3) The standards shall be set at a level reasonably achievable for each class and model of motor vehicle when operating in a reasonably sound mechanical condition, allowing for the effects of installed motor vehicle pollution control devices and the motor vehicle's age and total mileage.

(4) The standards shall be designed so that motor vehicles failing the test specified in Section 44012 will be operated, as soon as possible, with a substantial reduc-

tion in emissions, and shall be revised from time to time as experience justifies.

(b) The department, in cooperation with the state board, shall research and prescribe test procedures to be applied in inspecting motor vehicles under this chapter, which procedures shall be simple, cost-effective, and consistent with Section 44012. The department may revise the test procedures from time to time as experience justifies. To the extent that any test procedure revision requires new equipment, or a change in equipment, at licensed smog check stations, the department shall provide a reasonable period of time for the acquisition and installation of that new or changed equipment.

(c) Notwithstanding any other provision of this chapter, the maximum emission standards and test procedures prescribed in subdivisions (a) and (b) for a motor vehicle class and model-year shall not be more stringent than the emission standards and test procedures under which that motor vehicle's class and model-year was certified. Emission standards and test procedures prescribed by the department shall ensure that not more than 5 percent of the vehicles or engines, which would otherwise meet the requirements of this part, will fail the inspection and maintenance test for that class of vehicle or engine.

Added Stats 1982 ch 892 § 2. Amended Stats 1987 ch 425 § 2; Stats 1988 ch 1544 § 28; Stats 1994 ch 27 § 15 (AB 2018), effective March 30, 1994.

**Editor's Notes**—The amendment to this section by Stats 1994 ch 1 § 15, failed to become operative under the terms of Stats 1994 ch 27 § 66 which provides: Sections 1 to 61, inclusive, of Chapter 1 of the Statutes of 1994 shall not become operative.

**§ 44013. (Second of three; Operative date contingent; Operative term contingent) Prescription of maximum emission standards and test procedures**

(a)(1) The department, in cooperation with the state board, shall prescribe maximum emission standards to be applied in inspecting motor vehicles under this chapter.

(2) In prescribing the standards, the department shall undertake studies and experiments which are necessary and feasible, evaluate available data, and confer with automotive engineers.

(3) The standards shall be set at a level reasonably achievable for each class and model of motor vehicle when operating in a reasonably sound mechanical condition, allowing for the effects of installed motor vehicle pollution control devices and the motor vehicle's age and total mileage.

(4) The standards shall be designed so that motor vehicles failing the test specified in Section 44012 will be operated, as soon as possible, with a substantial reduction in emissions, and shall be revised from time to time as experience justifies.

(b) The department, in cooperation with the state board, shall research and prescribe test procedures to be applied in inspecting motor vehicles under this chapter, which procedures shall be simple, cost-effective, and consistent with Section 44012. The department may revise the test procedures from time to time as experience justifies. To the extent that any test procedure revision requires new equipment, or a change in equip-

ment, at licensed smog check stations, the department shall provide a reasonable period of time for the acquisition and installation of that new or changed equipment.

(c) Notwithstanding any other provision of this chapter, the maximum emission standards and test procedures prescribed in subdivisions (a) and (b) for a motor vehicle class and model-year shall not be more stringent than the emission standards and test procedures under which that motor vehicle's class and model-year was certified. Emission standards and test procedures prescribed by the department shall ensure that not more than 5 percent of the vehicles or engines, which would otherwise meet the requirements of this part, will fail the inspection and maintenance test for that class of vehicle or engine.

(d) Maximum emission standards established under this section shall not be adjusted downward based on the installation of an exhaust device.

(e) This section shall become inoperative five years from the date determined pursuant to Section 32 of the act adding this subdivision, and on the January 1 following that date is repealed.

Added Stats 1982 ch 892 § 2. Amended Stats 1987 ch 425 § 2; Stats 1988 ch 1544 § 28; Stats 1994 ch 27 § 15 (AB 2018), effective March 30, 1994, ch 1192 § 22 (SB 2050), operation contingent.

**Note**—Stats 1994 ch 1192 provides:

SEC. 32. (a) This act, except Section 29, shall not become operative until both of the following occur:

(1) The system required by subdivision (b) of Section 44060 of the Health and Safety Code for the electronic filing of certificates of compliance or noncompliance is determined to be operational by the Department of Consumer Affairs and that fact is reported by the department to the Secretary of State.

(2) The San Diego County Air Pollution Control District and the Ventura County Air Pollution Control District have sufficient funds available to implement the pilot program established pursuant to subdivision (b) of Section 43705 of the Health and Safety Code, as determined by each of those districts and reported by each district to the Secretary of State.

(b) On the date that all of the reports have been received by the Secretary of State pursuant to subdivision (a), subject to the exceptions stated in Section 33 of this act, this act shall be operative.

**§ 44013. (Third of three; Operative date contingent) Prescription of maximum emission standards and test procedures**

(a)(1) The department, in cooperation with the state board, shall prescribe maximum emission standards to be applied in inspecting motor vehicles under this chapter.

(2) In prescribing the standards, the department shall undertake studies and experiments which are necessary and feasible, evaluate available data, and confer with automotive engineers.

(3) The standards shall be set at a level reasonably achievable for each class and model of motor vehicle when operating in a reasonably sound mechanical condition, allowing for the effects of installed motor vehicle pollution control devices and the motor vehicle's age and total mileage.

(4) The standards shall be designed so that motor vehicles failing the test specified in Section 44012 will be operated, as soon as possible, with a substantial reduction in emissions, and shall be revised from time to time as experience justifies.

(b) The department, in cooperation with the state board, shall research and prescribe test procedures to be applied in inspecting motor vehicles under this chapter, which procedures shall be simple, cost-effective, and consistent with Section 44012. The department may revise the test procedures from time to time as experience justifies. To the extent that any test procedure revision requires new equipment, or a change in equipment, at licensed smog check stations, the department shall provide a reasonable period of time for the acquisition and installation of that new or changed equipment.

(c) Notwithstanding any other provision of this chapter, the maximum emission standards and test procedures prescribed in subdivisions (a) and (b) for a motor vehicle class and model-year shall not be more stringent than the emission standards and test procedures under which that motor vehicle's class and model-year was certified. Emission standards and test procedures prescribed by the department shall ensure that not more than 5 percent of the vehicles or engines, which would otherwise meet the requirements of this part, will fail the inspection and maintenance test for that class of vehicle or engine.

(d) This section shall become operative five years from the date determined pursuant to Section 32 of the act adding this section.

Added Stats 1994 ch 1192 § 22.5 (SB 2050), operative date contingent.

**Note**—Stats 1994 ch 1192 provides:

SEC. 32. (a) This act, except Section 29, shall not become operative until both of the following occur:

(1) The system required by subdivision (b) of Section 44060 of the Health and Safety Code for the electronic filing of certificates of compliance or noncompliance is determined to be operational by the Department of Consumer Affairs and that fact is reported by the department to the Secretary of State.

(2) The San Diego County Air Pollution Control District and the Ventura County Air Pollution Control District have sufficient funds available to implement the pilot program established pursuant to subdivision (b) of Section 43705 of the Health and Safety Code, as determined by each of those districts and reported by each district to the Secretary of State.

(b) On the date that all of the reports have been received by the Secretary of State pursuant to subdivision (a), subject to the exceptions stated in Section 33 of this act, this act shall be operative.

#### **§ 44013.5. (Operative date contingent; Operative term contingent) Certification of emissions retrofit device installations**

(a) If the department, in consultation with the state board, determines that substantial demand for emission retrofit devices exists, the department shall develop a program for the certification of emissions retrofit device installations by licensed installers. The department may require installers of emissions retrofit devices to be qualified pursuant to this chapter. The department may assess biennial license fees upon those installers in an amount not to exceed the reasonable cost of administering the emissions retrofit device certification program.

(b) The certification shall be performed at a referee or test-only station and shall be based on a visual inspection of the emissions retrofit device and its installation, and verification of the proper operation of any new or modified components that are a part of the emissions retrofit device, and not on the results of an emissions test.

(c) The department shall develop a program for the identification of retrofitted vehicles at smog check stations and for providing information required for the inspection of those systems to smog check stations.

(d) This section shall become inoperative pursuant to Section 33 of the act adding this section or, in any case, five years from the date determined pursuant to Section 32 of the act adding this section, and on the January 1 following the date upon which this section becomes inoperative, is repealed.

Added Stats 1994 ch 1192 § 23 (SB 2050), operation contingent. Amended Stats 1996 ch 1154 § 21 (AB 3020), effective September 30, 1996.

**Note**—Stats 1994 ch 1192 provides:

SEC. 32. (a) This act, except Section 29, shall not become operative until both of the following occur:

(1) The system required by subdivision (b) of Section 44060 of the Health and Safety Code for the electronic filing of certificates of compliance or noncompliance is determined to be operational by the Department of Consumer Affairs and that fact is reported by the department to the Secretary of State.

(2) The San Diego County Air Pollution Control District and the Ventura County Air Pollution Control District have sufficient funds available to implement the pilot program established pursuant to subdivision (b) of Section 43705 of the Health and Safety Code, as determined by each of those districts and reported by each district to the Secretary of State.

(b) On the date that all of the reports have been received by the Secretary of State pursuant to subdivision (a), subject to the exceptions stated in Section 33 of this act, this act shall be operative.

SEC. 33. Sections 14 and 23 of this act shall become inoperative if the Environmental Protection Agency finds that the economic incentive program contained in those sections is not an acceptable transportation control measure that will contribute to compliance with federal requirements for the use of transportation control measures in certain ozone nonattainment areas.

#### **§ 44014. Smog check stations and technicians; Licensing and qualifications; Provision for referee services; Fees**

(a) Except as otherwise provided in this chapter, the testing and repair portion of the program shall be conducted by smog check stations licensed by the department, and by smog check technicians who have qualified pursuant to this chapter.

(b) A smog check station may be licensed by the department as a smog check test-only station and, when so licensed, need not comply with the requirement for onsite availability of current service and adjustment procedures specified in paragraph (3) of subdivision (b) of Section 44030. A smog check technician employed by a smog check test-only station shall be qualified in accordance with this section.

(c)(1) The department shall supply a network of referees. A referee shall have no ownership interest in, or business or economic interest with, a smog check station. Referees may issue repair cost waivers, certificates of compliance or noncompliance, and hardship extensions, in accordance with regulations adopted by the department, and promote automotive training through community colleges and other training institutions certified by the department pursuant to Section 44030.5. Referees shall provide inspection services for specially constructed vehicles pursuant to Section 44017.4 and Section 9565 of the Vehicle Code and issue exhaust system certificates of compliance in accordance with Section 27150.2 of the Vehicle Code.

(2) The department may adopt regulations to establish qualification standards and any special administrative, operational, and licensure standards that the department determines to be necessary for the provision of referee services.

(3) The department may adopt, by regulation, a process by which vehicles that present prohibitive or unusual inspection circumstances are inspected by referees, including, but not limited to, the inspection of vehicles in which the manufacturer's physical or operational design presents inspection incompatibilities, vehicles equipped with emission control configurations that do not match United States Environmental Protection Agency or state board certified configurations, including direct import vehicles and vehicles with engine changes, and vehicles equipped with retrofit alternative fuel conversion kits.

(4)(A) A referee may charge a fee sufficient to cover the costs of providing referee services for inspections of specially constructed vehicles pursuant to Section 44017.4 and Section 9565 of the Vehicle Code, inspections pursuant to Section 27150.2 of the Vehicle Code, and other appropriate categories of referee services as determined by the department. Requirements applicable to the fee, including its amount, shall be established by the department by regulation and the amount may be adjusted to reflect changes in the Consumer Price Index, as published by the United States Bureau of Labor Statistics. The fee may be collected by either a contracted referee or by the department, if the department is providing the referee service.

(B) If the fee is imposed and collected by a contracted referee, the contracted referee shall deposit the fees collected from the vehicle owner into a separate trust account that the referee shall account for and manage in accordance with generally accepted accounting practices.

(C) If the fee is imposed and collected by the department, the fees shall be deposited into the Vehicle Inspection and Repair Fund.

(d) A smog check station may also be licensed as a repair-only station, and if so licensed, may perform repairs to reduce excessive emissions on vehicles which have failed the smog check test. Repair procedures and equipment requirements shall be established by the department. Technicians employed by a smog check repair-only station shall be qualified in accordance with this section.

(e) Smog check technicians are qualified to test and repair only those classes and categories of vehicles for which they have passed a qualification test administered by the department. The department shall provide for smog check technicians to be qualified for different categories of motor vehicle inspection based on vehicle classification and model-year.

(f) The consumer protection-oriented quality assurance portion of the program, including the provision of referee services, may be conducted by one or more private entities pursuant to contracts with the department.

Added Stats 1982 ch 892 § 2. Amended Stats 1984 ch 1591 § 1; Stats 1988 ch 1544 § 29; Stats 1989 ch 1154 § 8; Stats 1994 ch 27 § 16 (AB 2018), effective March 30, 1994; Stats 1997 ch 803 § 6 (AB 1492); Stats 2002 ch 569 § 1 (SB 1420); Stats 2010 ch 258 § 4 (AB 2289), effective January 1, 2011.

#### § 44014.2. Certification program

(a) The department shall develop a program for the voluntary certification of licensed smog check stations, or the department may accept a smog check station certification program proposed by accredited industry representatives. The certification program, which may be called a "gold shield" program, shall be for the purpose of providing consumers, whose vehicles fail an emissions test at a test-only facility, an option of services at a single location to prevent the necessity for additional trips back to the test-only facility for vehicle certification. The department shall establish inspection-based performance standards consistent with Section 44014.6 for stations certified under this program that the stations would be required to meet to be eligible to issue certificates of compliance or noncompliance for vehicles selected pursuant to Sections 44010.5 and 44014.7, or vehicles identified by the department as gross polluters.

(b) The department shall adopt regulations that apply to all enhanced areas of the state, including those areas subject to the enhanced program pursuant to Section 44003.5, that permit both of the following:

(1) Any vehicle that fails a required smog test at a test-only facility may be repaired, retested, and certified at a facility licensed pursuant to Section 44014, and certified pursuant to subdivision (a).

(2) Any vehicle that is identified as a gross polluter may be repaired, retested, and certified at a facility licensed pursuant to Section 44014, and certified pursuant to subdivision (a).

(c) Smog check stations that seek voluntary certification under this section shall enter into an agreement with the department to provide repair services pursuant to Section 44062.1.

(d) An agreement made pursuant to this section shall not be deemed to be a contract subject to the requirements of Part 2 (commencing with Section 10100) of Division 2 of the Public Contract Code.

Added Stats 1996 ch 1088 § 3 (AB 2515), effective September 30, 1996. Amended Stats 2002 ch 1001 § 4 (AB 2637); Stats 2009 ch 307 § 100 (SB 821), effective January 1, 2010; Stats 2010 ch 258 § 5 (AB 2289), effective January 1, 2011.

#### § 44014.4. Advertisement

(a) A licensed smog check station that has been certified pursuant to Section 44014.2 may advertise that fact, and the advertisement may include the scope of work established by the program.

(b) It is an unfair business practice and a violation of Section 17500 of the Business and Professions Code for any licensed smog check station that is not so certified to advertise as having obtained certification or as complying with the scope of work, code of ethics, or certification standards established by the certification program.

Added Stats 1996 ch 1088 § 4 (AB 2515), effective September 30, 1996.

#### § 44014.5. Test-only facilities; Standards

(a) The enhanced program shall provide for the testing and retesting of vehicles in accordance with Sections 44010.5 and 44014.2 and this section.

(b) The repair of vehicles at test-only facilities is prohibited, except that the minor repair of components damaged by station personnel during inspection at the station, any minor repair that is necessary for the safe

operation of a vehicle while at a station, or other minor repairs, such as the reconnection of hoses or vacuum lines, may be undertaken at no charge to the vehicle owner or operator if authorized in advance in writing by the department.

(c) The department shall make available to consumers of test-only facilities a list, compiled by region, of smog check stations licensed to make repairs of vehicular emission control systems. A test-only facility shall not refer a vehicle owner to any particular provider of vehicle repair services in which the test-only facility has a financial interest.

(d)(1) The department shall establish standards for training, equipment, performance, or data collection for test-only facilities.

(2)(A) The department shall establish inspection-based performance standards consistent with Section 44014.6 that test-only stations would be required to meet to be eligible to issue certificates of compliance or non-compliance for vehicles selected pursuant to Section 44010.5 or 44014.7, or vehicles identified by the department as gross polluters. Failure at any time to meet these standards shall result in suspension of the certification to test these vehicles granted by the department. A test-only station not meeting the performance standards may continue to issue certificates of compliance and noncompliance for other vehicles. The department shall adopt measures to ensure the requirements of this subparagraph are met, including through the use of the computer database and computer network authorized by Section 44037.1.

(B) The department shall provide the test-only station with written or electronic notice, prior to the suspension pursuant to subparagraph (A). The notice shall specify the grounds for the suspension and provide that the station within five days of receipt of the notice may request a hearing before the chief of the bureau or his or her designee to contest the suspension. The request for hearing shall be in writing or shall be made electronically. Receipt of this hearing request shall stay the suspension pending the outcome of the hearing. If a request for hearing is not made, the chief of the bureau shall issue a final written decision of suspension within 10 days of the last date that a hearing could have been requested.

(C) The hearing conducted by the chief of the bureau or his or her designee shall be held not later than 10 days from the date that the request for a hearing is received by the chief of the bureau. The hearing requirements of Section 44072 shall not apply. The chief of the bureau shall render a written decision within 10 days of the hearing. The decision may rescind the suspension, affirm the suspension, or order any other appropriate action. Administrative review, before an administrative law judge, of the decision of the chief of the bureau may be sought within 30 days of the date of the decision.

(D) The department may adopt regulations to implement this paragraph.

(e) The department shall prohibit test-only facilities from engaging in other business activities that represent a conflict of interest, as determined by the department. Upon implementation of the performance standards described in paragraph (2) of subdivision (d), ownership of

a test-and-repair station by an owner of a test-only facility shall not be considered a conflict of interest.

(f) The test-only facility may charge a fee, established by the department, sufficient to cover the facility's cost to perform the tests or services, including, but not limited to, referee services and the issuance of waivers and hardship extensions required by this chapter. In addition, the station shall charge and collect the certificate fee established pursuant to Section 44060. This subdivision shall apply only to facilities contracted for pursuant to subdivision (e) of Section 44010.5.

(g) The department shall ensure that there is a sufficient number of test-only facilities to provide convenient testing for the following vehicles:

(1) All vehicles identified and confirmed as gross polluters pursuant to Section 44081 and Section 27156 of the Vehicle Code.

(2)(A) Vehicles initially identified as gross polluters by a smog check station licensed as a test-and-repair station may be issued a certificate of compliance by a test-only facility or by a licensed smog check station certified pursuant to Section 44014.2.

(B) For purposes of this section, the department shall implement a program that allows vehicles initially identified as gross polluters to be repaired and issued a certificate of compliance by a facility licensed and certified pursuant to Section 44014.2.

(3) All vehicles designated by the department pursuant to Sections 44014.7 and 44020.

(4) Vehicles issued an economic hardship extension in the previous biennial inspection of the vehicle.

(h) The department shall provide a sufficient number of test-only facilities authorized to perform referee functions to provide convenient testing for those vehicles that are required to report to, and receive a certificate of compliance from, a test-only facility by this chapter, including all of the following:

(1) All vehicles seeking to utilize state-operated financial assistance or inclusion in authorized scrap programs.

(2) All vehicles unable to obtain a certificate of compliance from a licensed smog check station pursuant to subdivision (c) of Section 44015.

(3) Any other vehicles that may be designated by the department.

(i) Gross polluters shall be referred to a test-only facility, or a test-and-repair station that is both licensed and certified pursuant to Sections 44014 and 44014.2, for a postrepair inspection and retest pursuant to subdivision (g). Passing the emissions test is not a sufficient condition for receiving a certificate of compliance. A certificate of compliance shall only be issued to a vehicle that does not have any defects with its emission control system or any defects that could lead to damage of its emission control system, as provided in regulations adopted by the department.

Added Stats 1994 ch 27 § 17 (AB 2018), effective March 30, 1994. Amended Stats 1994 ch 1220 § 13 (AB 3132), effective September 30, 1994; Stats 1995 ch 982 § 1 (AB 63), effective October 16, 1995; Stats 1996 ch 1088 § 5 (AB 2515), effective September 30, 1996; Stats 1997 ch 803 § 7 (AB 1492); Stats 2002 ch 1001 § 5 (AB 2637); Stats 2010 ch 258 § 6 (AB 2289), effective January 1, 2011.

**§ 44014.6. Inspection-based performance standards; Criteria; Applicability**

(a) The inspection-based performance standards created for the certification program established pursuant to subdivision (a) of Section 44014.2 and subdivision (d) of Section 44014.5 shall be based on the same criteria.

(b) The performance standards described in subdivision (a) shall be applied to smog check technicians licensed pursuant to this chapter, if the department determines that is feasible.

Added Stats 2010 ch 258 § 7 (AB 2289), effective January 1, 2011.  
Amended Stats 2012 ch 728 § 92 (SB 71), effective January 1, 2013.

**§ 44014.7. Required receipt of certificate from test-only station**

(a) The department shall require 2 percent of the vehicles required to obtain a certificate of compliance each year in enhanced program areas to receive their certificate from a test-only facility.

(b) The department may require a number not to exceed 2 percent of the vehicles required to obtain a certificate of compliance each year in basic program areas to receive their certificate from a test-only facility.

(c) Three vehicles specified in subdivisions (a) and (b) shall be selected at random. The vehicles may be included among the vehicles subject to subdivision (d) of Section 44010.5, to the extent that the vehicles are registered in enhanced program areas. The review committee may review the selection process to ensure that it is a statistically significant representation of the vehicles subject to the basic and enhanced programs. The department shall select the vehicles and the Department of Motor Vehicles shall notify the owners of their obligation under this section pursuant to Section 4000.3 of the Vehicle Code. Selection shall be made from vehicles in an area where a test-only facility is located.

Added Stats 1994 ch 27 § 18 (AB 2018), effective March 30, 1994.

**§ 44015. Certification of certain vehicles prohibited; Issuance of certificates; Repair cost waivers; Economic hardship extensions; Responsibility of licensed motor vehicle dealers**

(a) A licensed smog check station shall not issue a certificate of compliance, except as authorized by this chapter, to any vehicle that meets the following criteria:

(1) A vehicle that has been tampered with.

(2) A vehicle identified pursuant to subparagraph (K) of paragraph (3) of subdivision (b) of Section 44036. A vehicle identified pursuant to subparagraph (K) of paragraph (3) of subdivision (b) of Section 44036 shall be directed to the department to determine whether an inadvertent error can explain the irregularity, or whether the vehicle otherwise meets smog check requirements, allowing the certificate for compliance to be issued, or the vehicle shall be reinspected by a referee or another smog check station.

(3) A vehicle that, prior to repairs, has been initially identified by the smog check station as a gross polluter. Certification of a gross polluting vehicle shall be conducted by a designated test-only facility, or a test-and-repair station that is both licensed and certified pursuant to Sections 44014 and 44014.2.

(4) A vehicle described in subdivision (c).

(b) If a vehicle meets the requirements of Section 44012, a smog check station licensed to issue certificates shall issue a certificate of compliance or a certificate of noncompliance.

(c)(1) A repair cost waiver shall be issued, upon request of the vehicle owner, by an entity authorized to perform referee functions for a vehicle that has been properly tested but does not meet the applicable emission standards when it is determined that no adjustment or repair can be made that will reduce emissions from the inspected motor vehicle without exceeding the applicable repair cost limit established under Section 44017 and that every defect specified by paragraph (2) of subdivision (a) of Section 43204, and by paragraphs (2) and (3) of subdivision (a) of Section 43205, has been corrected. A repair cost waiver issued pursuant to this paragraph shall be accepted in lieu of a certificate of compliance for the purposes of compliance with Section 4000.3 of the Vehicle Code. No repair cost waiver shall exceed two years' duration. No repair cost waiver shall be issued until the vehicle owner has expended an amount equal to the applicable repair cost limit specified in Section 44017.

(2) An economic hardship extension shall be issued, upon request of a qualified low-income motor vehicle owner, by an entity authorized to perform referee functions, for a motor vehicle that has been properly tested but does not meet the applicable emission standards when it is determined that no adjustment or repair can be made that will reduce emissions from the inspected motor vehicle without exceeding the applicable repair cost limit, as established pursuant to Section 44017.1, that every defect specified in paragraph (2) of subdivision (a) of Section 43204, and in paragraphs (2) and (3) of subdivision (a) of Section 43205, has been corrected, that the low-income vehicle owner would suffer an economic hardship if the extension is not issued, and that all appropriate emissions-related repairs up to the amount of the applicable repair cost limit in Section 44017.1 have been performed.

(d) No repair cost waiver or economic hardship extension shall be issued under any of the following circumstances:

(1) If a motor vehicle was issued a repair cost waiver or economic hardship extension in the previous biennial inspection of that vehicle. A repair cost waiver or economic hardship extension may be issued to a motor vehicle owner only once for a particular motor vehicle belonging to that owner. However, a repair cost waiver or economic hardship extension may be issued for a motor vehicle that participated in a previous waiver or extension program prior to January 1, 1998, as determined by the department. For waivers or extensions issued in the program operative on or after January 1, 1998, a waiver or extension may be issued for a motor vehicle only once per owner.

(2) Upon initial registration of all of the following:

(A) A direct import motor vehicle.

(B) A motor vehicle previously registered outside this state.

(C) A dismantled motor vehicle pursuant to Section 11519 of the Vehicle Code.

(D) A motor vehicle that has had an engine change.

(E) An alternate fuel vehicle.



(F) A specially constructed vehicle.

(e) Except as provided in subdivision (f), a certificate of compliance or noncompliance shall be valid for 90 days.

(f) Excluding any vehicle whose transfer of ownership and registration is described in subdivision (d) of Section 4000.1 of the Vehicle Code, and except as otherwise provided in Sections 4000.1, 24007, 24007.5, and 24007.6 of the Vehicle Code, a licensed motor vehicle dealer shall be responsible for having a smog check inspection performed on, and a certificate of compliance or noncompliance issued for, every motor vehicle offered for retail sale. A certificate issued to a licensed motor vehicle dealer shall be valid for a two-year period, or until the vehicle is sold and registered to a retail buyer, whichever occurs first.

(g) A test may be made at any time within 90 days prior to the date otherwise required.

Added Stats 1982 ch 892 § 2. Amended Stats 1983 ch 456 § 3; Stats 1988 ch 1544 § 30; Stats 1994 ch 27 § 19, effective March 30, 1994, Stats 1995 ch 982 § 2, effective October 16, 1995, Stats 1996 ch 1088 § 6, effective September 30, 1996; Stats 1997 ch 803 § 8, ch 804 § 2; Stats 1998 ch 92 § 1, effective July 3, 1998, Stats 1999 ch 83 § 113, ch 355 § 1; Stats 2001 ch 335 § 1 (AB 854); Stats 2002 ch 1001 § 6 (AB 2637); Stats 2005 ch 270 § 1 (SB 731), effective January 1, 2006; Stats 2010 ch 258 § 8 (AB 2289), effective January 1, 2011.

#### § 44015.5. Certificate of compliance; Certificate of noncompliance

(a) A certificate of compliance shall not be issued to any new motor vehicle or motor vehicle with a new motor vehicle engine which is not certified by the state board, and which is the subject of a transaction prohibited by Section 43152 or 43153.

(b) With respect to a new motor vehicle or motor vehicle with a new motor vehicle engine not certified by the state board which is in violation of Article 1.5 (commencing with Section 43150) of Chapter 2, but which is not the subject of a transaction prohibited by Section 43152 or 43153, a certificate of noncompliance shall be issued. The certificate of noncompliance shall indicate the basis for nonconformity and the data shall be sent to the state board.

Added Stats 1990 ch 1433 § 18 (SB 1874).

#### § 44016. Specifications and procedures

The department shall, with the cooperation of the state board and after consultation with the motor vehicle manufacturers and representatives of the service industry, research, establish, and update as necessary, specifications and procedures for motor vehicle maintenance and tuneup procedures and for repair of motor vehicle pollution control devices and systems. Licensed repair stations and qualified mechanics shall perform all repairs in accordance with specifications and procedures so established.

Added Stats 1982 ch 892 § 2. Amended Stats 1987 ch 425 § 3; Stats 1988 ch 1544 § 31.

#### § 44017. Cost limitations; Repair cost waiver; Failure to pass visible smoke test

(a) Except as otherwise provided in this section or Section 44017.1, a motor vehicle owner shall qualify for a repair cost waiver only after expenditure of not less

than four hundred fifty dollars (\$450) for repairs, including parts and labor.

(b) The limit established pursuant to subdivision (a) shall not become operative until the department issues a public notice declaring that the program established pursuant to Section 44010.5 is operational in the relevant geographical areas of the state, or until the date that testing in those geographic areas is operative using loaded mode test equipment, as defined in this article, whichever occurs first. Prior to that time, the following cost limits shall remain in effect:

(1) For motor vehicles of 1971 and earlier model years, fifty dollars (\$50).

(2) For motor vehicles of 1972 to 1974, inclusive, model years, ninety dollars (\$90).

(3) For motor vehicles of 1975 to 1979, inclusive, model years, one hundred twenty-five dollars (\$125).

(4) For motor vehicles of 1980 to 1989, inclusive, model years, one hundred seventy-five dollars (\$175).

(5) For motor vehicles of 1990 to 1995, inclusive, model years, three hundred dollars (\$300).

(6) For motor vehicles of 1996 and later model years, four hundred fifty dollars (\$450).

(c) The department shall periodically revise the repair cost limits specified in subdivisions (a) and (b) in accordance with changes in the Consumer Price Index, as published by the United States Bureau of Labor Statistics.

(d) No repair cost limit shall be imposed in those cases where emissions control equipment is missing or is partially or totally inoperative as a result of being tampered with.

(e)(1) No repair cost waiver shall be issued where a motor vehicle has failed the visible smoke test created by the department pursuant to Section 44012.1, unless paragraph (2) applies, or the vehicle is owned by a low-income person, as defined in Section 44062.1 in which case the repair cost limit applicable pursuant to subdivision (b) of Section 44017.1 shall apply.

(2) By January 1, 2008, the department shall adopt regulations allowing a repair cost waiver, with the repair cost limit specified in subdivision (a), where a motor vehicle has failed the visible smoke test component of a smog check inspection, for individuals under economic hardship but who do not meet the definition of low-income person, as defined in Section 44062.1. The regulations shall make eligible for the waiver those individuals whose household means fall below the level necessary to achieve a modest standard of living without assistance from public programs. The department shall consult authoritative information sources including, but not limited to, the United States Census Bureau, the Department of Finance, and the California Budget Project.

Added Stats 1982 ch 892 § 2. Amended Stats 1988 ch 1544 § 32; Stats 1989 ch 1154 § 9; Stats 1994 ch 27 § 20 (AB 2018), effective March 30, 1994, ch 1220 § 14 (AB 3132), effective September 30, 1994; Stats 1995 ch 982 § 6 (AB 63), effective October 16, 1995; Stats 1996 ch 124 § 74 (AB 3470); Stats 1997 ch 803 § 10 (AB 1492), ch 804 § 4 (AB 57); Stats 2006 ch 761 § 2 (AB 1870), effective January 1, 2007.

#### § 44017.1. "Low-income motor vehicle owner"; Repair cost limit; Issuance of economic hardship extension

(a) For purposes of this section, "low-income motor vehicle owner" means a person whose income does not exceed 185 percent of the federal poverty level.

(b) Notwithstanding subdivision (a) of Section 44017, for low-income motor vehicle owners qualified under Section 44062.1, the repair cost limit, including parts and labor, shall be two hundred fifty dollars (\$250) in all areas where the program operates. However, the department may decrease that amount, to not more than two hundred dollars (\$200), if the department determines that participation rates are unsatisfactory.

(c) Until such time as a repair assistance program becomes effective pursuant to Section 44062.1, an economic hardship extension shall be issued upon request to a qualified low-income motor vehicle owner whose motor vehicle has been tested but does not meet applicable emissions standards and the necessary repairs exceed the repair cost limit specified in subdivision (b).

Added Stats 1997 ch 803 § 11 (AB 1492), ch 804 § 5 (AB 57). Amended Stats 1999 ch 67 § 14 (AB 1105), effective July 6, 1999.

### § 44017.3. Information required to be posted at smog check stations

(a) The department shall provide a licensed smog check station with a sign informing customers about options when their vehicle fails a biennial smog check inspection, including, but not limited to, the option for qualified consumers to retire vehicles, receive repair assistance, or obtain repair cost waivers. The sign shall include the department's means of contact, including, but not limited to, its telephone number and Internet Web site. This sign shall be posted conspicuously in an area frequented by customers. The sign shall be required in all licensed smog check stations.

(b) In stations where licensed smog check technician repairs are not performed, the station shall have posted conspicuously in an area frequented by customers a statement that repair technicians are not available and repairs are not performed.

Added Stats 1990 ch 1324 § 1 (AB 3106). Amended Stats 1991 ch 386 § 3 (SB 290); Stats 1992 ch 674 § 7 (SB 1792); Stats 1994 ch 27 § 21 (AB 2018), effective March 30, 1994; Stats 1995 ch 982 § 7 (AB 63), effective October 16, 1995; Stats 2009 ch 307 § 101 (SB 821), effective January 1, 2010.

### § 44017.4. Inspection of specially constructed vehicles

(a) Upon registration with the Department of Motor Vehicles, a passenger vehicle or pickup truck that is a specially constructed vehicle, as defined in Section 580 of the Vehicle Code, shall be inspected by stations authorized to perform referee functions. This inspection shall be for the purposes of determining the engine model-year used in the vehicle or the vehicle model-year, and the emission control system application. The owner shall have the option to choose whether the inspection is based on the engine model-year used in the vehicle or the vehicle model-year.

(1) In determining the engine model-year, the referee shall compare the engine to engines of the era that the engine most closely resembles. The referee shall assign the 1960 model-year to the engine in any specially constructed vehicle that does not sufficiently resemble a previously manufactured engine. The referee shall require only those emission control systems that are applicable to the established engine model-year and that the engine reasonably accommodates in its present form.

(2) In determining the vehicle model-year, the referee shall compare the vehicle to vehicles of the era that the vehicle most closely resembles. The referee shall assign the 1960 model-year to any specially constructed vehicle that does not sufficiently resemble a previously manufactured vehicle. The referee shall require only those emission control systems that are applicable to the established model-year and that the vehicle reasonably accommodates in its present form.

(b) Upon the completion of the inspection, the referee shall affix a tamper-resistant label to the vehicle and issue a certificate that establishes the engine model-year or the vehicle model-year, and the emission control system application.

(c) The Department of Motor Vehicles shall annually provide a registration to no more than the first 500 vehicles that meet the criteria described in subdivision (a) that are presented to that department for registration pursuant to this section. The 500-vehicle annual limitation does not apply to the renewal of registration of a vehicle registered pursuant to this section.

Added Stats 2001 ch 871 § 1 (SB 100). Amended Stats 2002 ch 693 § 1 (SB 1578).

### § 44017.5. Alternative work day schedule at referee stations

At the earliest possible date, as determined by the bureau, the bureau shall implement at the referee stations, where appropriate, an alternative workday schedule which substitutes Saturday working hours in lieu of another day during the Monday through Friday workweek, in order to provide for increased availability of referee station services.

Added Stats 1990 ch 1324 § 2 (AB 3106). Amended Stats 1995 ch 91 § 91 (SB 975).

### § 44018. Advisory safety and fuel efficiency checks; Exemptions

(a) The motor vehicle inspection program may include advisory safety equipment maintenance checks, fuel efficiency checks, or both, on the motor vehicle if the department finds that cost-effective methods for conducting those checks exist and that the cost of the inspection to the vehicle owner due to the additional checks would not be increased by more than 10 percent. The department shall specify the equipment to be checked and the procedures for conducting those checks.

(b) Notwithstanding subdivision (a), a motor vehicle sold at retail by a lessor-dealer licensed pursuant to Chapter 3.5 (commencing with Section 11600), or a dealer licensed pursuant to Chapter 4 (commencing with Section 11700), of Division 5 of the Vehicle Code shall not be subject to an advisory safety equipment maintenance check pursuant to this section.

Added Stats 1982 ch 892 § 2. Amended Stats 1984 ch 410 § 1; Stats 1985 ch 230 § 1.

### § 44019. Certificates of compliance for public agency vehicles

(a) Every public agency, including, but not limited to, a publicly owned public utility, owning or operating any motor vehicle that is exempt from annual renewal of registration, and is otherwise subject to this chapter, shall obtain for the vehicle a certificate of compliance

with the same frequency as is required for vehicles subject to renewal of registration. The cost limitations specified in Section 44017 do not apply to any vehicle owned or operated by a public agency.

(b) Certificates of compliance required by subdivision (a) shall be issued if the vehicle meets the requirements of Section 44012 using a test analyzer system meeting the requirements of the department. Any certificate so issued shall be indexed by vehicle license plate number or vehicle identification number and retained by the public agency for not less than three years, and shall be available for inspection by the department.

(c) Every public agency subject to subdivision (a) shall annually report to the department the number of certificates issued, the number of motor vehicles owned, and the schedule under which the motor vehicles were issued certificates of compliance.

(d) The department may accept proof of compliance with this section other than by a certificate of compliance.

Added Stats 1988 ch 1544 § 34. Amended Stats 1989 ch 1154 § 10.

**§ 44020. Testing and servicing of fleet vehicles by fleet owner; Conditions; Initial and renewal license fees**

Notwithstanding any other provision of this chapter, the department may license any registered owner of a fleet of 10 or more motor vehicles subject to this chapter, who so elects, to implement and conduct the tests and to perform necessary service and adjustment on the fleet's vehicles under this chapter, subject to all of the following conditions:

(a) The registered owner's facilities or personnel, or both, or a designated contractor of the registered owner, shall be licensed by the department as a fleet smog check station, and the test and repair system shall conform, in the department's determination, with all provisions of this chapter and all rules and regulations adopted by the department. The regulations shall provide for adequate onsite inspection by the department. Mobile testing equipment certified by the department may be used in accordance with procedures established by the department. The department may prohibit the use of mobile testing equipment if violations occur.

(b) A license issued under this section is subject to Sections 44035, 44050, and 44072.10, and may be suspended or revoked by the department whenever the department determines, on the basis of random periodic spot checks of the owner's inspection system and fleet vehicles, that the system fails to conform or that certificates of compliance have been issued by the owner in violation of regulations adopted by the department. Any person licensed to conduct tests and service and adjustments under this section is deemed to have consented to provide the department with whatever access, information, and other cooperation the department reasonably determines are necessary to facilitate the random periodic spot checks.

(c) The department or its contractor, on a random periodic basis, shall inspect or observe the inspections performed by licensed fleet smog check stations on not less than 2 percent of the total business fleet vehicles subject to this chapter.

(d) A fleet owner licensed to conduct tests or make repairs pursuant to this chapter shall issue certificates of compliance for motor vehicles. The cost limits in Section 44017 and the economic hardship extension provisions in this chapter shall not apply to any motor vehicle owned by a fleet owner licensed pursuant to this section.

(e) Notwithstanding subdivision (d), certificates of compliance or noncompliance prepared solely for the disposal or sale of motor vehicles owned by a fleet owner licensed pursuant to this section shall be subject to the cost limits in Section 44017.

(f) The department shall establish initial and renewal license fees, which shall not exceed the reasonable costs of administering this section.

(g) Notwithstanding any other provision of this section, fleets consisting of vehicles for hire or vehicles which accumulate high mileage, as defined by the department, shall go to a test-only station when a smog check certificate of compliance is required. Initially, high mileage vehicles shall be defined as vehicles which accumulate 50,000 miles or more each year. In addition, fleets which do not operate high mileage vehicles may be required to obtain certificates of compliance from the test-only station if they fail to comply with this chapter.

(h) Notwithstanding any other provision of this chapter, the department shall have the authority, by regulation, to require testing of vehicle fleets consistent with regulations adopted by the Environmental Protection Agency, if necessary to meet the emission reduction performance standard established by the agency, as determined by the department.

Added Stats 1982 ch 892 § 2. Amended Stats 1990 ch 1433 § 19 (SB 1874); Stats 1991 ch 386 § 4 (SB 290), ch 1054 § 1.5 (SB 245); Stats 1994 ch 27 § 22 (AB 2018), effective March 30, 1994; Stats 1995 ch 982 § 8 (AB 63), effective October 16, 1995.

**§ 44024. New technologies**

(a) The department, in cooperation with the state board, shall investigate new technologies, including the role of onboard diagnostic systems in vehicles, as a means both for detecting excess emissions and defective emission control equipment, and for assisting in determining what repairs would be effective.

(b) To incorporate new technologies into the program, the department may institute the following changes if the department determines that the changes will be cost-effective and convenient to vehicle owners:

- (1) The schedule for testing and certifying vehicles.
- (2) The location and method for complying with the test requirements otherwise applicable under this chapter.
- (3) The equipment requirements and repair procedures, including the imposition of new or revised diagnostic procedures, to be used at licensed smog check stations.
- (4) The training, skill, and licensing requirements for smog check technicians.
- (5) The applicable test procedures and emission standards, as applied at smog check stations, and during roadside inspection.

Added Stats 1994 ch 27 § 25 (AB 2018), effective March 30, 1994. Amended Stats 2012 ch 728 § 93 (SB 71), effective January 1, 2013.

**§ 44024.5. Statistical and emissions profiles and data of vehicles; Report; Pilot program to exempt vehicles from biennial certification requirement**

(a) The department shall compile and maintain statistical and emissions profiles and data from motor vehicles that are subject to the motor vehicle inspection program. The department may use data from any source, including remote sensing data, in use data, and other motor vehicle inspection program data, to develop and confirm the validity of the profiles, to evaluate the program, and to assess the performance of smog check stations. The department shall undertake these requirements directly or seek a qualified vendor for these services.

(b) The department, in cooperation with the state board, shall perform analyses of data collected pursuant to subdivision (a) and report the results to the public annually, beginning no later than July 1, 2011. The report shall include, at a minimum, all of the following:

(1) An independent validation of the evaluation methods, findings, and conclusions presented in the report.

(2) The percentage of vehicles that initially passed a smog check inspection and then failed a subsequent inspection as indicated by the data collected pursuant to subdivision (a).

(3) The percentage of vehicles that initially failed a smog check inspection and then failed a subsequent inspection as indicated by the data collected pursuant to subdivision (a).

(4) An estimate of excessive emissions resulting from vehicles identified in paragraphs (2) and (3).

(5) A best-efforts explanation regarding the reasons vehicles identified in paragraphs (2) and (3) inappropriately failed or passed an inspection.

(6) Recommended changes to the smog check program to reduce to a minimum the excess emissions identified in paragraph (4). In developing the recommended changes, the department and the state board shall undertake a thorough evaluation of the best practices of other state smog check inspection programs, and shall include in the recommendations how these other state best practices can be incorporated into California's program. Program recommendations pertaining to contracting with one or more entities to manage smog check stations shall not be implemented unless the Legislature, by statute, authorizes that contracting.

(7) A comparison to the findings of the report "Evaluation of the California Smog Check Program Using Random Roadside Data" dated March 12, 2009.

(c) The department and the state board, in consultation with the Inspection and Maintenance Review Committee, may determine that, in addition to the vehicles excepted pursuant to Section 44011, certain other motor vehicles may be excepted from the biennial certification requirements of this chapter without significantly compromising the emission reduction objectives set forth in the State Implementation Plan (SIP).

(d) The department may conduct a pilot program to except from the biennial certification requirement those vehicles that may be jointly determined by the department and the state board, after consultation with the Inspection and Maintenance Review Committee, to warrant exception. The department shall provide written notification to the Legislature specifying the number of

vehicles to be exempted as well as the geographic location and duration of the pilot program not less than 30 days prior to the implementation of the pilot program. The department shall submit the results of the pilot program to the state board and the Inspection and Maintenance Review Committee for review. Subject to the approval of the United States Environmental Protection Agency as an amendment to the SIP, the department may establish the exception program as a permanent program.

(e) For vehicles four model years old or less, the department shall use test data generated pursuant to Section 44014.7 to develop statistical and emissions profiles. The department may use data from any source, including remote sensing data, warranty repair and recall data, and other motor vehicle inspection program data, to develop and confirm the validity of the data. If the department and state board jointly determine that the emissions from a class of motor vehicles would potentially compromise the emission reduction objectives set forth in the SIP, the state board shall consider appropriate corrective action, including, but not limited to, recall pursuant to Section 43105.

Added Stats 1997 ch 802 § 4 (AB 208). Amended Stats 1999 ch 273 § 1 (SB 1301); Stats 2006 ch 760 § 17 (SB 1849), effective January 1, 2007; Stats 2010 ch 258 § 9 (AB 2289), effective January 1, 2011.

**§ 44025. Department as vendor clearinghouse**

The department shall act as a clearinghouse to provide access to the vendors who possess service information generated by the vehicle manufacturers.

Added Stats 1994 ch 27 § 26 (AB 2018), effective March 30, 1994.

**ARTICLE 3**

**Quality Assurance**

Section

- 44030. Development of standards for licensing of smog check stations
- 44030.5. Standards for certification of institutions and instructors
- 44031.5. Qualification and licensing requirements for smog check technicians
- 44032. Prerequisites to performing tests and repairs
- 44033. Authorization and requirements of license facilities; Limitations
- 44034. Annual license fees
- 44034.1. Examination fee for technician initial and renewal license
- 44035. Suspension or revocation of license; Hearing
- 44036. Referee stations; Certification of test equipment
- 44036.1. Manufacturers' proof of financial security
- 44036.2. Manufacturers to provide information on emission control system service
- 44036.3. Department to direct smog check stations and technicians to information sources
- 44036.5. Test analyzer system calibration gases; Gas blenders
- 44036.8. Use of smog check data when appealing Bureau of Automotive Repair citation
- 44037. Records of tests and repairs; Contents
- 44037.1. Centralized computer data base and network; Transmission of emission test results to data base
- 44037.2. Data base
- 44038. Transmission of data to department
- 44039. Publication of information summary
- 44040. Certificates of compliance and noncompliance and repair cost waivers
- 44041. Bar code labels
- 44045.5. Qualifications to be met by smog check technician applicants; Categories and levels of licensure; Renewal
- 44045.6. Requirements for training of smog check technicians; Certification by established national training institution; Remedial training

**§ 44030. Development of standards for licensing of smog check stations**

(a) The department shall develop standards for the licensing of smog check stations. Tests, service, and adjustment at smog check stations shall be performed by a qualified smog check mechanic.

(b) The licensing standards for smog check stations may include, but are not limited to, requirements for all of the following:

(1) Use of computerized and tamper-resistant testing equipment, including, but not limited to, test analyzer systems meeting the current requirements of the department.

(2) Annual license renewal.

(3) Onsite availability of current emission control system information and service and adjustment procedures.

Added Stats 1988 ch 1544 § 37.

**§ 44030.5. Standards for certification of institutions and instructors**

The department shall develop standards for certification of institutions and instructors for purposes of providing training of smog check mechanics. The standards shall include criteria for applications, manuals, textbooks, laboratory equipment, laboratory exercises, hands-on work, examinations, and other matters the department determines necessary for a certified course of instruction.

The standards shall also specify the conditions under which an institution or instructor may be decertified, and under which a decertified institution or instructor may regain certification.

Added Stats 1987 ch 248 § 2. Amended Stats 1988 ch 1544 § 38.

**§ 44031.5. Qualification and licensing requirements for smog check technicians**

(a) No smog check technician may perform tests or make repairs required by this chapter, for compensation, unless qualified by the department for the class and category of vehicle being tested or repaired. To qualify, smog check technicians shall pass a qualification test administered by the department, in addition to meeting prerequisite minimum experience and training criteria established by the department, pursuant to Section 44045.5. Passage of the qualification test shall, and training may, also be required upon each biennial renewal of the smog check technician's license.

(b) The department shall prescribe training and periodic retraining courses for licensed smog check technicians pursuant to Section 44045.6.

(c) Whenever the department determines, through investigation, that a previously qualified smog check technician may lack the skills to reliably and accurately perform the test or repair functions within the required qualification, the department may prescribe for the technician one or more retraining courses which have been certified by the department. The smog check technician may request and be granted a hearing, pursuant to Chapter 5 (commencing with Section 11500) of Part 1 of Division 3 of Title 2 of the Government Code, on the department's determination. The request for a hearing shall be submitted within 30 days of the department's notification of its determination. A failure to complete

the prescribed retraining course within the time designated by the department, or to request a hearing within 30 days of the department's notification of its determination, shall result in loss of qualification. Upon a later completion of the prescribed department certified retraining course, the department may reinstate the smog check technician's qualification.

(d) Smog check technicians shall have the option to do hands-on work in lieu of written work in order to successfully complete the department certified training and retraining courses or may complete comparable military training as documented by submission of Verification of Military Experience and Training (V-MET) records in lieu of meeting any other training-related requirements of this section.

(e) The institution administering the department certified training or retraining courses shall issue a certificate of completion to each person who successfully completes the certified courses. The certificate shall be valid for two years.

(f) The department may, by regulation, establish procedures relating to the issuance and use of photo identification cards for licensed technicians.

Added Stats 1982 ch 892 § 2. Amended Stats 1987 ch 248 § 4; Stats 1988 ch 1544 § 40; Stats 1989 ch 1154 § 11; Stats 1991 ch 386 § 5 (SB 290); Stats 1991-1992 1st Ex Sess ch 21 § 60 (ABX1 66), effective March 1, 1993; Stats 1994 ch 27 § 28 (AB 2018), effective March 30, 1994, ch 1220 § 15 (AB 3132), effective September 30, 1994; Stats 2002 ch 405 § 70 (AB 2973).

**§ 44032. Prerequisites to performing tests and repairs**

No person shall perform, for compensation, tests or repairs of emission control devices or systems of motor vehicles required by this chapter unless the person performing the test or repair is a qualified smog check technician and the test or repair is performed at a licensed smog check station. Qualified technicians shall perform tests of emission control devices and systems in accordance with Section 44012.

Added Stats 1982 ch 892 § 2. Amended Stats 1988 ch 1544 § 41; Stats 1994 ch 27 § 29 (AB 2018), effective March 30, 1994.

**§ 44033. Authorization and requirements of license facilities; Limitations**

(a)(1) Any facility meeting the requirements established by the department pursuant to this chapter may be licensed as a test-only, test and repair, or repair-only smog check station. A licensed smog check station shall display an identifying sign prescribed by the department in a manner conspicuous to the public.

(2) A licensed smog check station certified pursuant to Section 44014.2 shall display an identifying sign prescribed by the department.

(b) No licensed or certified smog check station shall require, as a condition of performing the test, that any needed repairs or adjustment be done by the person, or at the facility of the person, performing the test.

(c) If a motor vehicle, including a commercial vehicle, is tested at a facility licensed to perform tests and repairs pursuant to this chapter, the facility shall provide the customer with a written estimate pursuant to Section 9884.9 of the Business and Professions Code. The written estimate shall contain a notice to the customer stating that the customer may choose another

smog check station to perform needed repairs, installations, adjustments, or subsequent tests.

(d) Charges for testing or repair, or both, shall be separately stated.

(e) The department shall require the posting of station licenses and qualified technicians' certificates prominently in each place of business so as to be readily visible to the public.

Added Stats 1982 ch 892 § 2. Amended Stats 1986 ch 951 § 21.5; Stats 1988 ch 1544 § 42; Stats 1991 ch 386 § 6 (SB 290); Stats 1994 ch 27 § 30 (AB 2018), effective March 30, 1994; Stats 1996 ch 1088 § 9 (AB 2515), effective September 30, 1996.

#### § 44034. Annual license fees

Annual license fees for smog check stations and biennial license fees for smog check technicians shall be imposed by the department, but shall not exceed the reasonable cost of administering the qualifications and licensing program.

Added Stats 1982 ch 892 § 2. Amended Stats 1988 ch 1544 § 43; Stats 1989 ch 1154 § 12; Stats 1994 ch 27 § 31 (AB 2018), effective March 30, 1994.

#### § 44034.1. Examination fee for technician initial and renewal license

The department may impose an examination fee, sufficient to recover the reasonable cost of administering, developing, and updating the examination, for initial and biennial renewal smog check technician applicants. Payment of the fee entitles the applicant to be scheduled for an examination. The department may contract for collection of the fee.

Added Stats 1989 ch 1154 § 13. Amended Stats 1994 ch 27 § 32 (AB 2018), effective March 30, 1994.

#### § 44035. Suspension or revocation of license; Hearing

(a) A smog check station's license or a qualified smog check technician's qualification may be suspended or revoked by the department, after a hearing, for failure to meet or maintain the standards prescribed for qualification, equipment, performance, or conduct. The department shall adopt rules and regulations governing the suspension, revocation, and reinstatement of licenses and qualifications and the conduct of the hearings.

(b) The department or its representatives, including quality assurance inspectors, shall be provided access to licensed stations for the purpose of examining property, station equipment, repair orders, emissions equipment maintenance records, and any emission inspection items, as defined by the department.

Added Stats 1982 ch 892 § 2. Amended Stats 1987 ch 248 § 5; Stats 1988 ch 1544 § 44; Stats 1994 ch 27 § 33 (AB 2018), effective March 30, 1994.

#### § 44036. Referee stations; Certification of test equipment

(a) The consumer protection-oriented quality assurance portion of the motor vehicle inspection program shall ensure uniform and consistent tests and repairs by all qualified smog check technicians and licensed smog check stations throughout the state, and shall include a number of stations providing referee functions available to consumers.

(b)(1) All licensed smog check stations shall utilize original equipment and replacement parts that are cer-

tified by the department. The department may enter into a contract for the supply or service of certified equipment with the manufacturers and service providers of this equipment. The department shall afford to the smog check station the option to purchase the equipment or service directly from the contractor or any other provider of certified equipment or service, as determined by the department. A contract executed pursuant to this paragraph may authorize compensation to the contractor as provided in subdivision (c) of Section 44037.2.

(2) The department shall charge a fee for certification testing of the equipment or the replacement parts. The fee for certification testing of equipment shall be fixed by the department based upon its actual costs of certification testing, shall be calculated from the time that the equipment is submitted for certification testing until the time that the certification testing is complete, and shall not exceed ten thousand dollars (\$10,000). The fee for certification testing of replacement parts shall be determined by the department based upon its actual costs of certification testing, shall be calculated from the time that the replacement part is submitted for certification testing until the time that the certification testing is complete, and shall not exceed two thousand five hundred dollars (\$2,500).

(3) The department shall adopt, and may revise, standards for certification and decertification of the equipment, that may include a device for testing of emissions of oxides of nitrogen. The department shall adopt, and update as necessary, equipment standards that may include a test analyzer system containing any or all of the following components:

(A) A microprocessor to control test sequencing, selection of proper test standards, the automatic pass or fail decision, and the format for the test report and the recorded data file. The microprocessor shall be capable of using a standardized programming language specified by the department.

(B) An exhaust gas analysis portion with an analyzer for hydrocarbons, carbon monoxide, and carbon dioxide that is designed to accommodate an optional oxides of nitrogen analyzer. An oxides of nitrogen analyzer shall be required in the enhanced program areas.

(C) Equipment necessary to perform visual and functional tests of emission control devices required by the department.

(D) A device to accept and record motor vehicle identification information, including a device capable of reading barcode information pursuant to regulations of the state board. The device shall have the ability to identify, with the cooperation of the Department of Motor Vehicles, smog inspections performed on vehicles sold by used car dealers.

(E) A device to provide a printed record of the test process and diagnostic information for the motorist.

(F) A mass storage device capable of storing not less than the minimum amount of program software and data specified by the department.

(G) A device to provide for the periodic modification of all program and data files contained on the mass storage device, using a standardized form of removable media conforming to specifications of the department.

(H) A device that provides for the storage of test records on a standardized form of removable media conforming to specifications of the department.

(I) One or more communications ports conforming to the specifications established by the department as necessary to provide real time communication, or communication that is consistent with maintaining a superior quality assurance program and efficient information transfer, between the test equipment and the centralized computer database through the computer network maintained by the department pursuant to Section 44037.1.

(J) An interface capable of monitoring equipment used with loaded mode testing, idle testing, onboard diagnostic testing, or other tests prescribed by the department.

(K) A real-time computer data program that would prevent a certificate of compliance from being issued if a vehicle is identified as having an excessive variance from computer data for that vehicle, mismatched information, or other irregularities.

(L) Any other features that the department determines are necessary to increase the effectiveness of the program, including, but not limited to, a loaded mode dynamometer for purposes of oxides of nitrogen detection, and other equipment necessary to detect nonexhaust-related volatile organic compound emissions, such as those found in fuel system evaporative emissions and crankcase ventilation emissions.

(c)(1) The department shall not require smog check stations to use equipment that meets revised standards for certification and decertification of equipment pursuant to subdivision (b) earlier than January 1, 2013.

(2) If existing smog check stations licensed pursuant to this chapter or training institutions certified pursuant to Section 44030.5 are required to make investments of more than ten thousand dollars (\$10,000) to acquire equipment to meet the requirements of this subdivision, the department shall submit recommendations to the Governor and the Legislature for any appropriate mitigation measures, including, but not limited to, subsidies, equipment leases, grants, or loans.

(3) The department may defer the requirement for any equipment, external to the chassis of the test analyzer system, needed to read barcode information, until a substantial portion of the vehicles subject to this chapter are equipped with barcode labels.

(4) Prior to the imposition of a requirement for equipment meeting the requirements of subdivision (b), every smog check station shall use equipment meeting the specifications of the department in effect on January 1, 1996.

(d) The quality assurance portion shall provide for inspections of licensed smog check stations, data collection and forwarding, equipment accuracy checks, operation of referee stations, and other necessary functions. If the services are contracted for pursuant to subdivision (e) of Section 44014, the department shall prepare detailed specifications and solicit bids from private entities for the implementation of the quality assurance functions.

(e) The department may revise the specifications for equipment annually if the cost thereof is less than 20 percent of the total system cost. A more comprehensive revision to the specifications may be required not more often than every five years.

(f)(1) Equipment manufacturers shall furnish to the department, and shall install, software and hardware

updates as specified by the department. The department shall allow equipment manufacturers six months, from the date the department issues its proposed specifications for periodic software and hardware updates, to obtain department approval that the updates meet the proposed specifications and to install the updates in all equipment subject to the updates. During the first 30 days of the six-month period, the manufacturers shall be permitted to review and to comment upon the proposed specifications. However, notwithstanding any other provision of this section, the department may order manufacturers to install software and hardware changes in a shorter period of time upon a finding by the department that a previously installed update does not meet current specifications.

(2) The department may establish hardware specifications, performance standards, and operational requirements for the certification and continuing certification of the equipment specified in subdivision (b).

(3) A manufacturer's failure to furnish or install required software updates or to meet the specifications, standards, or requirements established pursuant to paragraph (2), is cause for the department to decertify the manufacturer's test analyzer system or to issue a citation to the manufacturer. The citation shall specify the nature of the violation and may specify a civil penalty not to exceed one thousand dollars (\$1,000) for each day the manufacturer fails to furnish or install the specified software updates by the specified period. In assessing a civil penalty pursuant to this paragraph, the department shall give due consideration, in determining the appropriateness of the amount of the civil penalty, to factors such as the gravity of the violation, the good faith of the manufacturer, and the history of previous violations.

(4) The citations shall be served pursuant to subdivision (c) of Section 11505 of the Government Code. The manufacturer may request a hearing in accordance with Chapter 5 (commencing with Section 11500) of Part 1 of Division 3 of Title 2 of the Government Code. A request for a hearing shall be submitted in writing within 30 days of service of the citation, and shall be delivered to the office of the department in Sacramento. Hearings and related procedures under this paragraph shall be conducted in the same manner as proceedings for adjudication of an accusation under that Chapter 5, except as otherwise specified in this article.

(5) If within 30 days from the date of service of the citation, the manufacturer fails to request a hearing, the citation shall be deemed the final order of the department.

(6) Any failure to comply with the final order of the department for payment of a civil penalty, or to pay the amount specified in any settlement executed by the licensee and the Director of Consumer Affairs, is cause for decertification of the manufacturer's test analyzer system.

Added Stats 1988 ch 1544 § 46. Amended Stats 1989 ch 1154 § 14; Stats 1992 ch 674 § 8 (SB 1792); Stats 1994 ch 27 § 34 (AB 3018), effective March 30, 1994; Stats 1997 ch 803 § 12 (AB 1492); Stats 2001 ch 357 § 4 (AB 1560); Stats 2010 ch 258 § 10 (AB 2289), effective January 1, 2011.

#### § 44036.1. Manufacturers' proof of financial security

The department may require that equipment manufacturers, submitting equipment for certification pursu-

ant to Section 44036, submit proof of financial security, including, but not limited to, insurance sufficient to cover product liability claims, and secured funds for prepaid warranty or service contracts.

Added Stats 1994 ch 27 § 35 (AB 2018), effective March 30, 1994.

**§ 44036.2. Manufacturers to provide information on emission control system service**

(a) To ensure uniform and consistent inspection, tests, and repairs by all qualified smog check technicians and licensed smog check stations, and to ensure consumer protection, manufacturers of motor vehicles shall provide, or cause to be provided, all emission control system service information that is necessary to properly inspect, test and repair those vehicles. Unless otherwise provided, that information shall be required for all 1980 and newer model-year vehicles and shall consist of all of the following:

(1) General specifications showing the make, model, and classification of the vehicle.

(2) The identification, location, and description of all emission control equipment on the vehicle.

(3) The manufacturer's recommended visual and functional inspection procedures for each emissions-related component.

(4) Air injection and evaporative emission purge strategies.

(5) All vehicle manufacturer-specific data stream information, excluding bidirectional control information and reprogramming information unless required by state or federal statute or regulation.

(b) Beginning with the 1998 model year, all emissions-related information required by this section, including diagnostic, service, and training information supplied by vehicle manufacturers to any franchised dealer, shall be provided in an electronic format that is readily accessible, or that can be made readily accessible, to private diagnostic assistance service information vendors or intermediaries, if that information is provided or made available in this format by manufacturers to dealers. In determining the allowable format, the state board shall ensure compatibility with any service information format requirements specified by the Environmental Protection Agency.

(c)(1) The state board shall require motor vehicle manufacturers to provide the service information necessary to comply with this section as a condition of certification.

(2) Should the manufacturer fail to provide the service information necessary to comply with subdivision (a) for any vehicle within an engine family within one year of its retail introduction, the state board may withhold certification for all engine families for subsequent model years, until such time as the manufacturer provides the necessary service information.

(3) The department shall periodically conduct surveys to determine whether the service information and tool requirements imposed by federal and state law are being fulfilled by actual field availability of the information and tools.

(d) The manufacturer shall make accessible, through the vehicle's standard data link, the version number or part number of the vehicle's current computer memory

program to allow smog check technicians to determine if the manufacturer's most up-to-date program is installed in the vehicle's computer. This requirement shall apply to all vehicles with reprogrammable computer memory in the vehicle's computer beginning with the 1999 model year. Until the manufacturer provides an electronic computer program identifier system, the manufacturer shall use a mechanical identification system to identify the computer's current program.

(e)(1) Those manufacturers that do not use reprogrammable technology for the vehicle's computer shall use either a mechanical or electronic identification system to identify the current program of the vehicle's computer.

(2) The manufacturer shall also provide or cause to be provided an engine family reprogramming cross-reference to aid smog check technicians in determining the proper computer memory program for that engine. The cross-reference shall either be published by the manufacturer or made available to private diagnostic service information vendors or intermediaries for compilation and distribution.

(f)(1) The information required to be provided under this section shall be limited to only that information which is made available by manufacturers to franchised dealers or other persons engaged in the repair, diagnosing, or servicing of motor vehicles or motor vehicle engines needed to make use of the emissions control diagnostic system prescribed under Section 207 of the Federal Clean Air Act Amendments of 1990 and such other information including instructions for making emission-related diagnosis and repairs. If any of the emissions-related service information required by this section is provided to the manufacturer's franchised dealers in advance of the specific requirements of this section, that information shall also be made available by manufacturers, directly or indirectly, to smog check stations and repair technicians. Manufacturers shall only be required to provide information to vendors or intermediaries in the same manner and format as provided to franchised dealers.

(2) The service information shall be made compatible with computer systems commonly used in the aftermarket repair industry. In addition, the vendor or intermediary may offer the information by other common distribution means when electronic means are unavailable. No information or format will be required in the service information beyond that which is provided by new car manufacturers to franchise dealers.

(g) The provisions of this section that apply with respect to 1994 and newer model-year vehicles shall become inoperative if the state board determines that the Environmental Protection Agency has adopted rules relative to the provision of emissions-related service information for 1994 and newer model-year vehicles.

Added Stats 1994 ch 725 § 1 (AB 2852). Amended Stats 1996 ch 380 § 1 (AB 3072).

**§ 44036.3. Department to direct smog check stations and technicians to information sources**

(a) The department shall direct licensed smog check stations and technicians to private diagnostic assistance service information vendors or intermediaries who possess the electronically formatted information acquired



under Section 44036.2, or with any other emissions-related information needed to improve the effectiveness of smog checks.

(b) The provisions of this section that apply with respect to 1994 and newer model-year vehicles shall become inoperative if the state board determines that the Environmental Protection Agency has adopted rules relative to the provision of emissions-related service information for 1994 and newer model-year vehicles.

Added Stats 1994 ch 725 § 2 (AB 2852).

**§ 44036.5. Test analyzer system calibration gases; Gas blenders**

(a) The department shall set standards for test analyzer system (TAS) calibration gases and shall establish criteria to certify and decertify gas blenders who blend, fill, or sell TAS calibration gases.

(b) On and after January 1, 1990, no person shall blend, fill, or sell any TAS calibration gases unless certified by the department and no person shall use in a TAS calibration gases which are not certified.

Added Stats 1989 ch 1154 § 15.

**§ 44036.8. Use of smog check data when appealing Bureau of Automotive Repair citation**

The data collected by the equipment used by a smog check station, as required by regulations of the bureau, may be used by a licensed smog check station technician or operator when appealing a citation issued by the bureau.

Added Stats 1990 ch 1324 § 3 (AB 3106). Amended Stats 1994 ch 27 § 36 (AB 2018), effective March 30, 1994; Stats 1995 ch 91 § 92 (SB 975).

**§ 44037. Records of tests and repairs; Contents**

(a) The department shall compile and maintain records, using the sampling methodology necessary to ensure their scientific validity and reliability, of tests and repairs performed by qualified smog check technicians at licensed smog check stations pursuant to this chapter on all of the following information:

(1) The motor vehicle identification information and the test data collected at the station.

(2) The number of maintenance and repair operations performed on motor vehicles that fail to pass a test conducted pursuant to this chapter.

(3) The correlation between maintenance and repairs recommended by the department pursuant to Section 44016 and maintenance and repairs performed.

(4) The charges assessed for the service and repairs and the correlation between the amount charged for repairs and the amount of emission reduction.

(5) Data received and compiled through the use of the centralized computer database and computer network to be established pursuant to Section 44037.1, and any other information determined to be essential by the department for program enhancement to achieve greater efficiency, consumer protection, cost-effectiveness, convenience, or emission reductions.

(6) The frequency of specific smog check stations issuing a passing certificate for vehicles that have failed a previous inspection at other smog check stations within the preceding 30 days.

(b) A written summary of the information specified in subdivision (a) shall be available annually for the tech-

nicians and smog check stations in each district and to the public upon request.

Added Stats 1982 ch 892 § 2. Amended Stats 1988 ch 1544 § 47; Stats 1991 ch 386 § 7 (SB 290); Stats 1994 ch 27 § 37 (AB 2018), effective March 30, 1994, ch 1220 § 15.3 (AB 3132), effective September 30, 1994; Stats 2006 ch 538 § 405 (SB 1852), effective January 1, 2007.

**§ 44037.1. Centralized computer data base and network; Transmission of emission test results to data base**

(a) On or before January 1, 1995, the department shall design and establish the equipment necessary to operate a centralized computer data base and computer network that is readily accessible by all licensed smog check technicians on a real time basis.

(b) The centralized computer data base and network shall be designed with all of the following capabilities:

(1) To provide smog check technicians with immediate access to vehicle-specific information regarding the location of all emission control equipment, pattern failure data, and other vehicle-specific technical information relevant to the efficient identification, diagnosis, and repair of emission problems.

(2) To provide smog check technicians and the department with information as to the date and result of prior smog check tests performed on each vehicle to discourage vehicle owners from shopping for certificates of compliance and to permit the department to identify smog check stations for further investigation as potential violators of this chapter.

(3) To provide the department with data on the failure rates and repair effectiveness for vehicles of each make and model year on a statewide basis, and by smog check station and technician, to facilitate identification of smog check stations and technicians as potential violators of this chapter.

(4) Upon a determination that a smog check station or technician has engaged in a pattern of conduct violating this chapter, or that a vehicle failed one or more emissions tests before obtaining a certificate of compliance, to provide the information necessary to identify and contact vehicle owners who obtained certificates from the station or technician, or may have obtained certificates of compliance in violation of this chapter, for purposes of requiring the retesting of their vehicles.

(5) To be compatible with the eventual transition to a fully computerized smog certification program that will not require the use of printed certificates as evidence of compliance.

(6) To be compatible with bar code scanning of vehicles as provided in Section 44041.

(7) To permit ongoing entry of information from each smog check station into the centralized data base to enlarge and improve the data base on a continuous basis.

(8) To be compatible with the department's record-keeping and compilation requirements established by Section 44037.

(9) To meet the needs of a remote-sensing program to identify gross polluters, as specified by the department.

(10) To meet any other needs specified by the department to enhance the benefits of the program through the storage of vehicle-specific information, such as that pertaining to voluntary repair and assistance and retiree-ment programs and to the referee station program.

(c) After January 1, 1995, each smog check station shall transmit vehicle data emission test results to the department's centralized data base. Each smog check station shall also transmit vehicle data and emission measurements made before and after repair. The department shall establish, by regulation, the form, manner, and frequency of the data transmittals.

Added Stats 1994 ch 27 § 38, effective March 30, 1994. Amended Stats 1997 ch 802 § 5 (AB 208).

#### § 44037.2. Data base

(a) The department may enter into a contract for telecommunication, programming, data analysis, data processing, and other services necessary to operate and maintain the centralized computer data base and computer network specified in Section 44037.1.

(b) The department may, for each transmittal of data to the centralized data base, charge a licensed smog check station a transaction fee established by the department. The transaction fee shall be sufficient to cover the actual costs of operating and maintaining the current data base and network.

(c) Any contract made pursuant to this section may authorize compensation to the contractor from the transaction fees established by the department. The contractor shall maintain the transaction fees, which may be collected directly by the contractor from the licensed smog check stations, in a separate custodial account that the contractor shall account for and manage in accordance with generally accepted accounting standards and principles.

Added Stats 1996 ch 1088 § 10 (AB 2515), effective September 30, 1996.

#### § 44038. Transmission of data to department

Until implementation of the centralized computer data base required pursuant to Section 44037.1, each smog check station shall transmit vehicle data and emission test or repair results to the department and transmit to the department vehicle data and emission measurements made before and after repair. The department shall establish, by regulation, the form, manner, and frequency of those data transmittals.

Added Stats 1982 ch 892 § 2. Amended Stats 1988 ch 1544 § 48; Stats 1994 ch 27 § 39 (AB 3018), effective March 30, 1994.

#### § 44039. Publication of information summary

A written summary of the required information applicable to smog check stations in each district shall be published semiannually by the department and made available upon request to the owner of any motor vehicle subject to this chapter.

Added Stats 1982 ch 892 § 2. Amended Stats 1988 ch 1544 § 49.

#### § 44040. Certificates of compliance and noncompliance and repair cost waivers

The department may require certificates of compliance, certificates of noncompliance, and repair cost waivers to contain a unique number encoded in bar code. These certificates may be sold to licensed smog check stations by the department, printed by test analyzer systems, or transmitted by electronic means. The department, with the cooperation of the Department of Motor

Vehicles, shall periodically check certificates to determine their validity.

Added Stats 1988 ch 1544 § 50. Amended Stats 1994 ch 27 § 40 (AB 2018), effective March 30, 1994; Stats 1995 ch 982 § 9 (AB 63), effective October 16, 1995; Stats 1997 ch 803 § 13 (AB 1492).

#### § 44041. Bar code labels

In order to expedite emissions testing and to eliminate errors in the transcription of vehicle data, the department shall, in cooperation with the Department of Motor Vehicles, furnish bar code labels or bar coded documents to all vehicle owners at the time of their vehicle's annual registration renewal. The labels or documents shall contain vehicle identification numbers and other vehicle-specific information, to be determined by the department, which can be recorded by smog check station technicians utilizing the scanning devices required by Section 44036.

Added Stats 1994 ch 27 § 41 (AB 2018), effective March 30, 1994. Amended Stats 1994 ch 1220 § 15.5 (AB 3132), effective September 30, 1994.

#### § 44045.5. Qualifications to be met by smog check technician applicants; Categories and levels of licensure; Renewal

(a) This section describes the qualifications to be met by smog check technician applicants effective January 1, 1995. The department shall, by regulation, establish requirements for the licensure of smog check technicians which are necessary to enable the program to meet the applicable emission reduction performance standards, to include, at a minimum:

(1) Either of the following:

(A) Certification standards for all technicians in the program which are equivalent or superior to the standards applicable for certification by an established national certification or accrediting institution to perform service on automotive engines and electrical systems.

(B) Successful completion of a training program certified by the department under Section 44045.6.

(2) In addition to the requirement in paragraph (1), a minimum of two years experience performing repairs to motor vehicle emission control systems or experience approved by the department, or an associate degree in an automotive technology curriculum or an equivalent degree as determined by the department.

(3) An examination process that effectively determines whether applicants are all of the following:

(A) Knowledgeable regarding the visual, functional, and exhaust and evaporative emissions inspection and testing procedures specified by the department, including a demonstrated understanding of loaded mode testing principles, purpose, procedures and equipment.

(B) Knowledgeable regarding misfire detection, air injection testing, closed-loop system testing, and generic idle adjustment procedures specified by the department.

(C) Capable of using emissions manuals and tuneup labels to properly identify required emission control systems and components on any vehicle subject to the enhanced program.

(4) Not later than July 1, 1995, the examination shall use state-of-the-art technology, which may include computer simulations or other computer-based examination formats to determine whether applicants can properly

identify, diagnose, and repair emission-related problems. The department may contract for the development and administration of this examination.

(b) The department shall not license any technician unless the department has determined that the person is able to perform the inspection, testing, and repair tasks required under the program on all vehicles subject to the program, except that the department may limit this requirement to specified makes or models of vehicles if a technician requests licensing limited to specified makes or models of vehicles.

(c) The department may establish more than one category or level of licensure, and may provide for the licensing of interns or trainees if those persons do all of their test and repair work under the supervision of a licensed technician.

(d) The department shall require the renewal of smog check technician licenses every two years, and shall establish any necessary and appropriate requirements for renewal.

Added Stats 1994 ch 27 § 42 (AB 2018), effective March 30, 1994.

**§ 44045.6. Requirements for training of smog check technicians; Certification by established national training institution; Remedial training**

(a) The department shall, by regulation, establish requirements for the training of smog check technicians which are necessary to enable the program to meet the applicable emission reduction performance standards, to include, at a minimum, all of the following:

(1) Criteria for facilities, instructors, equipment, reference materials, and instructional materials.

(2) A detailed outline of lectures and laboratory work.

(3) A final examination and recommended passing score.

(4) In lieu of the requirements in paragraphs (1) to (3), inclusive, the department may accept certification by an established national training institution of training in relevant curricula, including electrical systems, engine performance, and electronic emissions diagnostics.

(b) Training facilities meeting the requirements of subdivision (a) shall be certified by the department to provide smog check training.

(c) The department may require remedial training at a certified training facility or may take disciplinary action, whichever the department determines to be the most appropriate, for any licensed technician who the department determines cannot perform inspections, testing, or repairs as required under the program. The failure to complete the remedial training when required by the department shall be a ground for revocation or suspension of a smog check technician's license under Section 44072.2.

(d) The department may contract to ensure the availability of training and retraining courses required by this chapter whenever these courses are not otherwise available. Charges for courses offered by contractors pursuant to this subdivision shall be borne by course attendees.

Added Stats 1994 ch 27 § 43 (AB 2018), effective March 30, 1994.

**ARTICLE 4**  
**Penalties**

Section

44050. Remedies; Penalties; Issuance of citation; Administrative fine;

Section

Considerations; Order of abatement; Form of citation; Failure to comply with order; Adoption of regulations; Deposit of fines

44051. Contested citation; Hearing; Informal citation conference

44052. Civil penalty for separate violations

44055. Nonrenewal of license for failure to pay civil penalty or administrative fine

44056. Violations; Penalties; Exceptions

44057. Injunctions and restraining orders against violations

44058. Violations as misdemeanors

44059. Perjury

**§ 44050. Remedies; Penalties; Issuance of citation; Administrative fine; Considerations; Order of abatement; Form of citation; Failure to comply with order; Adoption of regulations; Deposit of fines**

(a) In addition to or in lieu of any other remedy or penalty, including, but not limited to, education, training, or an office conference, the department may issue a citation to a licensee, contractor, or fleet owner for a violation of the requirements of this chapter or a regulation adopted pursuant to this chapter. The citation may contain an order of abatement or the assessment of an administrative fine, or both.

(b) An administrative fine issued pursuant to this section shall be at least one hundred dollars (\$100) but not more than five thousand dollars (\$5,000) for each violation. In assessing a fine, the department shall give due consideration to the appropriateness of the amount of the fine, including an evaluation of all of the following:

(1) The nature, gravity, severity, and seriousness of the violation.

(2) The persistence of the violation.

(3) The good faith or willfulness of the violator.

(4) The history of previous violations by that violator, including the commission of numerous and repeated violations.

(5) The failure to perform work for which money was received.

(6) The making of any false or misleading statement in order to induce a person to authorize repair work or pay money.

(7) The failure to make restitution to consumers affected by the violation.

(8) The extent to which the violator has mitigated or attempted to mitigate any damage or injury caused by the violation.

(9) The degree of incompetence or negligence in the performance of duties and responsibilities.

(10) The purposes and goals of this chapter and other matters as may be appropriate.

(c) An order of abatement issued pursuant to this section shall fix a reasonable time for abatement of the violation. An order of abatement may require any or all of the following:

(1) The licensee, contractor, or fleet owner to whom the citation is issued to demonstrate how future compliance with this chapter, and regulations adopted pursuant to this chapter, will be accomplished. This demonstration may include, but is not limited to, submission of a corrective action plan.

(2) The smog check technician to successfully complete one or more retraining courses prescribed by the department pursuant to subdivision (c) of Section

44031.5, or successfully complete one or more advanced retraining courses prescribed by the department, or both.

(3) The smog check technician to perform no inspection or repair pursuant to this chapter until training courses prescribed by the department are successfully completed.

(d) A citation issued pursuant to this section shall be in writing and shall describe the nature of the violation and the specific provision of law determined to have been violated. The citation shall inform in writing the licensee, contractor, or fleet owner of the right to request a hearing, as described in Section 44051. If a hearing is not requested, payment of the administrative fine shall not constitute an admission of the violation charged. If a hearing is requested, the department shall provide a hearing in accordance with Chapter 5 (commencing with Section 11500) of Part 1 of Division 3 of Title 2 of the Government Code, except insofar as those provisions are inconsistent with the provisions of this article. Payment of the administrative fine shall be due 30 days after the citation was issued if a hearing is not requested, or when a final order is entered if a hearing is requested. The department may enforce the administrative fine as if it were a money judgment pursuant to Title 9 (commencing with Section 680.010) of Part 2 of the Code of Civil Procedure.

(e) Failure to comply with an order of abatement or payment of an administrative fine issued by the department pursuant to this section is grounds for suspension or revocation of the license, or placing the licensee on probation.

(f) The department shall adopt regulations to establish procedures, including a penalty schedule, for assessing fines or penalties for violations of a requirement of this chapter or a regulation adopted pursuant to this chapter.

(g) Administrative fines collected pursuant to this section shall be deposited in the High Polluter Repair or Removal Account within the Vehicle Inspection and Repair Fund.

Added Stats 2010 ch 258 § 12 (AB 2289), effective January 1, 2011.

#### **§ 44051. Contested citation; Hearing; Informal citation conference**

(a) If a person cited pursuant to Section 44050 wishes to contest the citation, that person shall, within 30 days after service of the citation, file in writing a request for an administrative hearing to the chief of the bureau or a designee.

(b)(1) In addition to, or instead of, requesting an administrative hearing pursuant to subdivision (a), the person cited pursuant to Section 44050 may, within 30 days after service of the citation, contest the citation by submitting a written request for an informal citation conference to the chief of the bureau or a designee.

(2) Upon receipt of a written request for an informal citation conference, the chief of the bureau or a designee shall, within 60 days of the request, hold an informal citation conference with the person requesting the conference. The cited person may be accompanied and represented by an attorney or other authorized representative.

(3) If an informal citation conference is held, the request for an administrative hearing shall be deemed withdrawn and the chief of the bureau, or designee, may affirm, modify, or dismiss the citation at the conclusion of the informal citation conference. If so affirmed or modified, the citation originally issued shall be considered withdrawn and an affirmed or modified citation, including reasons for the decision, shall be issued. The affirmed or modified citation shall be mailed to the cited person and that person's counsel, if any, within 10 days of the date of the informal citation conference.

(4) If a cited person wishes to contest a citation affirmed or modified pursuant to paragraph (3), the person shall, within 30 days after service of the modified or affirmed citation, contest the affirmed or modified citation by submitting a written request for an administrative hearing to the chief of the bureau or a designee. An informal citation conference shall not be held on affirmed or modified citations.

Added Stats 2010 ch 258 § 15 (AB 2289), effective January 1, 2011.

#### **§ 44052. Civil penalty for separate violations**

(a) If a citation lists more than one violation, the amount of the civil penalty or administrative fine assessed shall be stated separately for each statute and regulation violated.

(b) If a citation lists more than one violation arising from a single motor vehicle inspection or repair, the total penalties assessed shall not exceed five thousand dollars (\$5,000).

Added Stats 1985 ch 703 § 7. Amended Stats 2010 ch 258 § 17 (AB 2289), effective January 1, 2011.

#### **§ 44055. Nonrenewal of license for failure to pay civil penalty or administrative fine**

(a) Any failure by an applicant for a license or for the renewal of a license, or by any partner, officer, or director thereof, to comply with the final order of the department for the payment of an administrative fine, or to pay the amount specified in a settlement executed by the applicant and the Director of the Department of Consumer Affairs, shall result in denial of a license or of the renewal of the license. The department shall not allow the issuance of any certificate of compliance or noncompliance by a licensee until all civil penalties and administrative fines which have become final, or amounts agreed to in a settlement, have been paid by the licensee.

(b) The department may deny an application for the renewal of a test station or repair station license if the applicant, or any partner, officer, or director thereof, has failed to pay any civil penalty or administrative fine in accordance with this article.

Added Stats 1985 ch 703 § 10. Amended Stats 1987 ch 248 § 9; Stats 1991 ch 386 § 10 (SB 290); Stats 2010 ch 258 § 20 (AB 2289), effective January 1, 2011.

#### **§ 44056. Violations; Penalties; Exceptions**

(a) In addition to an administrative fine pursuant to Section 44050, any person who violates this chapter, or any order, rule, or regulation of the department adopted pursuant to this chapter, is liable for a civil penalty of not more than five thousand dollars (\$5,000) for each day in which each violation occurs. Any action to recover civil penalties shall be brought by the Attorney General in the

name of the state on behalf of the department, or may be brought by any district attorney, city attorney, or attorney for a district. In assessing a civil penalty pursuant to this subdivision, due consideration shall be given to the factors identified in subdivision (b) of Section 44050.

(b) The penalties specified in subdivision (a) do not apply to an owner or operator of a motor vehicle, except an owner or operator who does any of the following:

(1) Obtains, or who attempts to obtain, a certificate of compliance or noncompliance, a repair cost waiver, or an economic hardship extension without complying with Section 44015.

(2) Obtains, or attempts to obtain, a certificate of compliance, a repair cost waiver, or an economic hardship extension by means of fraud, including, but not limited to, offering or giving any form of financial or other inducement to any person for the purpose of obtaining a certificate of compliance for a vehicle that has not been tested or has been tested improperly.

(3) Registers a motor vehicle at an address other than the owner's or operator's residence address for the purpose of avoiding the requirements of this chapter.

(4) Obtains, or attempts to obtain, a certificate of compliance by other means when required to report to the test-only facility after being identified as a tampered vehicle or gross polluter pursuant to Section 44015 or 44081.

(c) Any person who obtains or attempts to obtain a repair cost waiver, or economic hardship extension pursuant to this chapter by falsifying information shall be subject to a civil penalty of not more than five thousand dollars (\$5,000), and shall be made ineligible for receiving any repair assistance of any kind pursuant to this chapter.

(d) Any person who obtains or attempts to obtain a certificate of compliance pursuant to this chapter by falsifying information shall be subject to a civil penalty of not more than five thousand dollars (\$5,000).

Added Stats 1982 ch 892 § 2, as H & S C § 44050. Amended Stats 1983 ch 456 § 4. Amended and renumbered by Stats 1985 ch 703 § 1.5. Amended Stats 1994 ch 27 § 46 (AB 2018), effective March 30, 1994; Stats 1995 ch 982 § 11 (AB 63), effective October 16, 1995; Stats 1997 ch 804 § 6 (AB 57); Stats 1998 ch 485 § 111 (AB 2803); Stats 2010 ch 258 § 21 (AB 2289), effective January 1, 2011.

#### § 44057. Injunctions and restraining orders against violations

A continuing violation of any provision of this chapter, or any order, rule, or regulation of the department adopted pursuant to this chapter, may be enjoined by the superior court of the county in which the violation is occurring. The action shall be brought by the attorney general in the name of the state on behalf of the department, or may be brought by any district attorney, city attorney, or attorney for a district. An action brought under this section shall conform to the requirements of Chapter 3 (commencing with Section 525) of Title 7 of Part 2 of the Code of Civil Procedure, except that it shall not be necessary to show lack of an adequate remedy at law or to show irreparable damage or loss.

In addition, if it is shown that the respondent continues, or threatens to continue, to violate any provision of this chapter, or any order, rule, or regulation of the department adopted pursuant to this chapter, it shall be

sufficient proof to warrant the immediate granting of a temporary restraining order.

Added Stats 1982 ch 892 § 2 as H & S C § 44051. Renumbered by Stats 1985 ch 703 § 2.

#### § 44058. Violations as misdemeanors

Any person who violates this chapter, or any order, rule, or regulation of the department adopted pursuant to this chapter, is guilty of a misdemeanor and shall be punished by a fine of not more than one thousand dollars (\$1,000) or by imprisonment for not more than six months, or by both, in lieu of the imposition of the civil penalties.

Added Stats 1985 ch 703 § 11.

#### § 44059. Perjury

The willful making of any false statement or entry with regard to a material matter in any oath, affidavit, certificate of compliance or noncompliance, or application form which is required by this chapter or Chapter 20.3 (commencing with Section 9880) of Division 3 of the Business and Professions Code, constitutes perjury and is punishable as provided in the Penal Code.

Added Stats 1986 ch 951 § 22, as H & S C § 44052. Renumbered by Stats 1987 ch 850 § 23.

## ARTICLE 5

### Financial Provisions

#### Section

44060. Certificates of compliance or noncompliance, repair cost waivers and economic hardship extensions; Form; Issuance; Fee

44060.5. (Repealed January 1, 2024) Smog abatement fee increase; Distribution of revenues

44061. Deposit and use of fees

44062. Abolishment of Vehicle Inspection and Automotive Repair Funds

44062.1. Low-income repair assistance program; Eligibility; Funding; Copayment; Data collection

44062.2. (First of two; Operative date contingent; Operative term contingent) Emission credit exchange program; Marketable emission reduction credits

44062.2. (Second of two; Operative date contingent) Emission credit exchange program; Marketable emission reduction credits

44062.3. Retiring of vehicle that has failed smog check inspection

44063. Transfer of litigation funds to Vehicle Inspection and Repair Fund

#### § 44060. Certificates of compliance or noncompliance, repair cost waivers and economic hardship extensions; Form; Issuance; Fee

(a) The department shall prescribe the form of the certificate of compliance or noncompliance, repair cost waivers, and economic hardship extensions.

(b) The certificates, repair cost waivers, and economic hardship extensions shall be in the form of an electronic entry filed with the department, the Department of Motor Vehicles, and any other person designated by the department. The department shall ensure that the motor vehicle owner or operator is provided with a written report, signed by the licensed technician who performed the inspection, of any test performed by a smog check station, including a pass or fail indication, and written confirmation of the issuance of the certificate.

(c)(1) The department shall charge a fee to a smog check station, including a test-only station, and a station providing referee functions, for a motor vehicle inspected

at that station that meets the requirements of this chapter and is issued a certificate of compliance, a certificate of noncompliance, repair cost waiver, or economic hardship extension.

(2) The fee charged pursuant to paragraph (1) shall be calculated to recover the costs of the department and any other state agency directly involved in the implementation, administration, or enforcement of the motor vehicle inspection and maintenance program, and shall not exceed the amount reasonably necessary to fund the operation of the program, including all responsibilities, requirements, and obligations imposed upon the department or any of those state agencies by this chapter, that are not otherwise recoverable by fees received pursuant to Section 44034.

(3) Except for adjustments to reflect changes in the Consumer Price Index, as published by the United States Bureau of Labor Statistics, the fee for each certificate, waiver, or extension shall not exceed seven dollars (\$7).

(4) Fees collected by the department pursuant to this subdivision shall be deposited in the Vehicle Inspection and Repair Fund. It is the intent of the Legislature that a prudent surplus be maintained in the Vehicle Inspection and Repair Fund.

(d)(1) Motor vehicles exempted under paragraph (4) of subdivision (a) of Section 44011 shall be subject to an annual smog abatement fee of twelve dollars (\$12). The department may also, by regulation, subject motor vehicles that are exempted under paragraph (5) of subdivision (a) of Section 44011 to the twelve dollar (\$12) annual smog abatement fee. Payment of the annual smog abatement fee shall be made to the Department of Motor Vehicles at the time of registration of the motor vehicle.

(2) Except as provided in subdivision (a) of Section 44091.1, fees collected pursuant to this subdivision shall be deposited on a daily basis into the Vehicle Inspection and Repair Fund.

(e) The sale or transfer of the certificate, waiver, or extension by a licensed smog check station or test-only station to any other licensed smog check station or to any other person, and the purchase or acquisition of the certificate, waiver, or extension, by any person, other than from the department, the department's designee, or pursuant to a vehicle's inspection or repair conducted pursuant to this chapter, is prohibited.

(f) Following implementation of the electronic entry certificate under subdivision (b), the department may require the modification of the analyzers and other equipment required at smog check stations to prevent the entry of a certificate that has not been issued or validated through prepayment of the fee authorized by subdivision (c).

(g) The fee charged by licensed smog check stations to consumers for a certificate, waiver, or extension shall be the same amount that is charged by the department.

Added Stats 1982 ch 892 § 2. Amended Stats 1983 ch 456 § 5; Stats 1984 ch 268 § 27.71, effective June 30, 1984; Stats 1987 ch 248 § 10; Stats 1988 ch 1544 § 56; Stats 1989 ch 1154 § 16; Stats 1990 ch 1432 § 2 (AB 4070), ch 1433 § 23 (SB 1874); Stats 1994 ch 27 § 47 (AB 2018), effective March 30, 1994; Stats 1995 ch 982 § 12 (AB 63), effective October 16, 1995; Stats 1997 ch 802 § 6 (AB 208); Stats 1999 ch 67 § 15 (AB 1105), effective July 6, 1999; Stats 2004 ch 230 § 8 (SB 1107), effective August 16, 2004.

**§ 44060.5. (Repealed January 1, 2024) Smog abatement fee increase; Distribution of revenues**

(a) Beginning July 1, 2008, the smog abatement fee described in subdivision (d) of Section 44060 shall be increased by eight dollars (\$8).

(b) Revenues generated by the increase described in this section shall be distributed as follows:

(1) The revenues generated by four dollars (\$4) shall be deposited in the Air Quality Improvement Fund created by Section 44274.5.

(2) The revenues generated by four dollars (\$4) shall be deposited in the Alternative and Renewable Fuel and Vehicle Technology Fund created by Section 44273.

(c) This section shall remain in effect only until January 1, 2024, and as of that date is repealed, unless a later enacted statute, that is enacted before January 1, 2024, deletes or extends that date.

Added Stats 2007 ch 750 § 3 (AB 118), effective January 1, 2008, repealed January 1, 2016. Amended Stats 2013 ch 401 § 4 (AB 8), effective September 28, 2013, repealed January 1, 2024.

**§ 44061. Deposit and use of fees**

The fees and penalties collected by the department pursuant to this chapter shall be deposited in the Vehicle Inspection and Repair Fund in accordance with the procedures established by the department, and is available to the department, as specified by Section 9886.2 of the Business and Professions Code, and, upon appropriation by the Legislature, to any other state agency directly involved in the implementation of the motor vehicle inspection program, to carry out its functions and duties specified in this chapter or in any other law.

Added Stats 1982 ch 892 § 2. Amended Stats 1984 ch 268 § 27.72, effective June 30, 1984; Stats 1988 ch 1544 § 56.3.

**§ 44062. Abolishment of Vehicle Inspection and Automotive Repair Funds**

The Vehicle Inspection Fund and the Automotive Repair Fund are hereby abolished. The balances in those funds are hereby transferred to the Vehicle Inspection and Repair Fund.

All fees collected by the department under this chapter and Chapter 20.3 (commencing with Section 9880) of Division 3 of the Business and Professions Code shall be deposited in the Vehicle Inspection and Repair Fund and are available to the department as specified by Section 9886.2 of the Business and Professions Code.

Added Stats 1988 ch 1544 § 56.6.

**§ 44062.1. Low-income repair assistance program; Eligibility; Funding; Copayment; Data collection**

(a) The department shall offer a repair assistance program through entities authorized to perform referee functions.

(b)(1) The repair assistance program shall be available to an individual who is a low-income motor vehicle owner, and who is either or both of the following:

(A) The owner of a motor vehicle that has failed a smog check inspection.

(B) The owner of a motor vehicle who was issued a notice to correct for an alleged violation of Section 27153 or 27153.5 of the Vehicle Code involving that vehicle, if

the vehicle subject to that notice has failed a smog check inspection subsequent to receiving the notice.

(2) The department shall offer repair cost assistance to individuals based on the cost-effectiveness and air quality benefit of the needed repair. Repair assistance may include retesting costs and the costs of repairs to remedy the violation of Section 27153 or 27153.5 of the Vehicle Code.

(3) An applicant for repair assistance shall file an application on a form prescribed by the department, and shall certify under penalty of perjury that the applicant meets the applicable eligibility standards.

(4) Verification of income eligibility shall be based on at least one form of documentation, as determined by the department, including, but not limited to, (A) an income tax return, (B) an employment warrant, or (C) a form of public assistance verification.

(c) The repair assistance program shall be funded by the High Polluter Repair or Removal Account.

(d) Repairs to motor vehicles that fail smog check inspections and are subsidized by the state through the program shall be performed at a repair station licensed and certified pursuant to Sections 44014 and 44014.2. Repairs shall be based upon a preapproved list of repairs for cost-effective emission reductions or repairs to remedy a violation of Section 27153 or 27153.5 of the Vehicle Code.

(e) The qualified low-income motor vehicle owner receiving repair assistance pursuant to this section shall contribute a copayment, as determined by the department, either in cash, or in emissions-related partial repairs as verified by a test-only station pursuant to paragraph (2) of subdivision (c) of Section 44015, or a combination thereof. If the repair cost exceeds the applicable repair cost limit, the department shall inform a motor vehicle owner of all options for compliance at the time of testing and repair.

(f) The department may increase its contribution toward the repair of a motor vehicle under this program in excess of the amount authorized for the repair of a high polluter pursuant to paragraph (1) of subdivision (b) of Section 44094, if the department determines that the expenditure is cost effective. In determining the cost-effectiveness of the expenditure, the department shall consider a failure of the visible smoke test, pursuant to Section 44012.1, and the costs associated with repairing a smoking vehicle.

(g) The department shall collect data from the program to provide information to develop recommendations to improve the program. Data collection shall include all of the following:

(1) The number of motor vehicle owners that are eligible for repair assistance.

(2) The number of eligible motor vehicle owners that use repair assistance funds.

(3) The potential for fraud.

(4) The average repair bills.

(5) The types of repairs being done.

(6) The amount of partial repairs done prior to receipt of repair assistance.

(7) The emissions benefits of providing repair assistance.

(h) For purposes of this section, "low-income motor vehicle owner" means a person whose income does not

exceed 225 percent of the federal poverty level, as published quarterly in the Federal Register by the United States Department of Health and Human Services.

Added Stats 1997 ch 804 § 10 (AB 57). Amended Stats 1999 ch 67 § 16 (AB 1105), effective July 6, 1999; Stats 2003 ch 482 § 1 (SB 708); Stats 2005 ch 565 § 1 (AB 383), effective January 1, 2006; Stats 2006 ch 760 § 18 (SB 1849), effective January 1, 2007, ch 761 § 4 (AB 1870), effective January 1, 2007; Stats 2010 ch 231 § 1 (AB 787), effective January 1, 2011.

**§ 44062.2. (First of two; Operative date contingent; Operative term contingent) Emission credit exchange program; Marketable emission reduction credits**

(a) The state board shall adopt, by regulation, procedures to establish an emissions credit exchange program whereby persons may contribute to the Vehicle Inspection, Repair, and Retrofit Fund, and receive equitable emission reduction credits for those contributions.

(b) Districts may establish procedures to generate marketable emission reduction credits from contributions toward the repair subsidy and vehicle retrofit subsidy program specified in Section 44062.1. Emission reduction credits generated pursuant to this subdivision may be used to meet or offset transportation control measure requirements, average vehicle ridership reductions, or other mobile source emission requirements, as determined by the district.

(c) In federal nonattainment areas, the credits established pursuant to subdivision (a) or (b) shall be allowed only for emission reductions that are in excess of the reasonable further progress goals established by Section 182 of the amendments enacted in 1990 to the Clean Air Act (P.L. 101-549), or in excess of alternative progress goals established in a state implementation plan pursuant to Section 182 of the Clean Air Act.

(d) This section shall become inoperative five years from the date determined pursuant to Section 32 of the act adding this subdivision, and on the January 1 following that date is repealed.

Added Stats 1994 ch 27 § 49 (AB 2018), effective March 30, 1994. Amended Stats 1994 ch 1192 § 28 (SB 2050), operation contingent.

**Note**—Stats 1994 ch 1192 provides:

SEC. 32. (a) This act, except Section 29, shall not become operative until both of the following occur:

(1) The system required by subdivision (b) of Section 440 of the Health and Safety Code for the electronic filing of certificates of compliance or noncompliance is determined to be operational by the Department of Consumer Affairs and that fact is reported by the department to the Secretary of State.

(2) The San Diego County Air Pollution Control District and the Ventura County Air Pollution Control District have sufficient funds available to implement the pilot program established pursuant to subdivision (b) of Section 43705 of the Health & Safety Code, as determined by each of those districts and reported by each district to the Secretary of State.

(b) On the date that all of the reports have been received by the Secretary of State pursuant to subdivision (a), subject to the exceptions stated in Section 33 of this act, this act shall be operative.

**§ 44062.2. (Second of two; Operative date contingent) Emission credit exchange program; Marketable emission reduction credits**

(a) The state board shall adopt, by regulation, procedures to establish an emissions credit exchange program whereby persons may contribute to the Vehicle Inspec-

tion and Repair Fund, and receive equitable emission reduction credits for those contributions.

(b) Districts may establish procedures to generate marketable emission reduction credits from contributions toward the repair subsidy program specified in Section 44062.1. Emission reduction credits generated pursuant to this subdivision may be used to meet or offset transportation control measure requirements, average vehicle ridership reductions, or other mobile source emission requirements, as determined by the district.

(c) The credits established pursuant to subdivision (a) or (b) shall not be allowed until the emission reduction goals established by the amendments enacted in 1990 to the Clean Air Act (P.L. 101-549) have been achieved.

(d) This section shall become operative five years from the date determined pursuant to Section 32 of the act adding this section.

Added Stats 1994 ch 1192 § 28.5 (SB 2050), operative date contingent.

**Editor's Notes**—For operation of act, see the 1994 note following the first version of § 44062.2, above.

**§ 44062.3. Retiring of vehicle that has failed smog check inspection**

(a) The owner of a motor vehicle that has been registered without substantial lapse, as defined by the department, in the state for at least two years prior to vehicle retirement, and that has failed the most recent smog check inspection for that vehicle, may retire the vehicle from operation at a dismantler under contract with the bureau, at any time after learning of the smog check failure. The department shall pay a person who retires his or her vehicle under this section one thousand five hundred dollars (\$1,500) for a low-income motor vehicle owner, as defined in Section 44062.1, and one thousand dollars (\$1,000) for all other motor vehicle owners. The department may pay a motor vehicle owner more than these amounts based on factors, including, but not limited to, the age of the vehicle, the emission benefit of the vehicle's retirement, the emission impact of any replacement vehicle, and the location of the vehicle in an area of the state with the poorest air quality.

(b) The department may permit vehicle retirement pursuant to subdivision (a) for any motor vehicle that has been registered without substantial lapse, as defined by the department, in the state for at least two years prior to vehicle retirement, and that fails any type of smog check inspection lawfully performed in the state.

Added Stats 2006 ch 761 § 5 (AB 1870), effective January 1, 2007. Amended Stats 2010 ch 231 § 2 (AB 787), effective January 1, 2011; Stats 2013 ch 437 § 2 (SB 459), effective January 1, 2014.

**§ 44063. Transfer of litigation funds to Vehicle Inspection and Repair Fund**

(a) There may be transferred into the Vehicle Inspection and Repair Fund the proceeds of the litigation known as M.D.L. Docket No. 150 AWT, as adjudicated in the United States District Court for the Central District of California.

(b) The money transferred pursuant to subdivision (a) shall be available upon appropriation by the Legislature, for use by the department to establish and implement a program for the repair, retrofit, or removal of gross polluting vehicles.

Added Stats 1994 ch 27 § 50 (AB 2018), effective March 30, 1994.

**ARTICLE 6**

**Public Information**

Section

- 44070. Public information program
- 44070.5. Public information program inclusions
- 44071. Funding

**§ 44070. Public information program**

(a) The department shall develop within the bureau, with the advice and technical assistance of the state board, a public information program for the purpose of providing information designed to increase public awareness of the smog check program throughout the state and emissions warranty information to motor vehicle owners subject to an inspection and maintenance program required pursuant to this chapter. The department shall provide, upon request, either orally or in writing, information regarding emissions related warranties and available warranty dispute resolution procedures.

(b) The telephone number and business hours, and the address if appropriate, of the emissions warranty information program shall be noticed on the vehicle inspection report provided by the test analyzer system for any vehicle which fails the analyzer test.

Added Stats 1984 ch 1591 § 3. Amended Stats 1988 ch 1544 § 57; Stats 1995 ch 91 § 93 (SB 975).

**§ 44070.5. Public information program inclusions**

(a) The department shall develop and continuously conduct a public information program, in consultation with the state board. The program shall be designed to develop and maintain public support and cooperation for the motor vehicle inspection and maintenance program and shall include information on all of the following:

- (1) The health damage caused by air pollution.
- (2) The contribution of automobiles to air pollution and the gross polluter problem.
- (3) Whether a motorist's vehicle could be a gross polluter without the motorist knowing.
- (4) The importance of maintaining a vehicle's emission control devices in good working order and the importance of the program.

(b) That information shall be disseminated by all means that the department determines to be feasible and cost-effective, including, but not limited to, television, newspaper, and radio advertising and trailers in movie theaters. The department may also utilize grass roots community networks, including local opinion leaders, churches, the PTA, and the workplace. Extensive marketing research shall be performed to identify the target population.

Added Stats 1994 ch 27 § 51 (AB 2018), effective March 30, 1994.

**§ 44071. Funding**

For purposes of implementing the smog check public awareness and emissions warranty information programs, the department shall use funds from the fee charged for each certificate of compliance or noncompliance which are deposited in the Vehicle Inspection and Repair Fund pursuant to Section 44060.

Added Stats 1984 ch 1591 § 3. Amended Stats 1988 ch 1544 § 57.5.



## ARTICLE 7

### Denial, Suspension, and Revocation

#### Section

44072. Suspension or revocation of license

44072.1. Grounds for denial of license

44072.2. Grounds for suspension, revocation, or disciplinary action against license

44072.3. What constitutes conviction

44072.4. Types of disciplinary action

44072.5. Surrender of license

44072.6. Jurisdiction to proceed with investigation of or action against licensee

44072.7. Limitations period

44072.8. Revocation or suspension of additional license

44072.9. Reinstatement of license

44072.10. Temporary suspension of license; Grounds; Fraudulent certification; Hearing and notice

44072.11. Refusal to issue or renew license; Revocation or suspension of license

#### § 44072. Suspension or revocation of license

Any license issued under this chapter and the regulations adopted pursuant to it may be suspended or revoked by the director. The director may refuse to issue a license to any applicant for the reasons set forth in Section 44072.1. The proceedings under this article shall be conducted in accordance with Chapter 5 (commencing with Section 11500) of Part 1 of Division 3 of Title 2 of the Government Code, and the director shall have all the powers granted therein.

Added Stats 1991 ch 386 § 11 (SB 290).

#### § 44072.1. Grounds for denial of license

The director may deny a license if the applicant, or any partner, officer, or director thereof, does any of the following:

(a) Fails to meet the qualifications established by the bureau pursuant to Articles 2 (commencing with Section 44010) and 3 (commencing with Section 44030) and the regulations adopted for the issuance of the license applied for.

(b) Was previously the holder of a license issued under this chapter, which license has been revoked and never reissued or which license was suspended and the terms of the suspension have not been fulfilled.

(c) Has committed any act that, if committed by any licensee, would be grounds for the suspension or revocation of a license issued pursuant to this chapter.

(d) Has committed any act involving dishonesty, fraud, or deceit whereby another is injured or whereby the applicant has benefited.

(e) Has acted in the capacity of a licensed person or firm under this chapter without having a license therefor.

(f) Has entered a plea of guilty or nolo contendere to, or been found guilty of, or been convicted of a crime substantially related to the qualifications, functions, or duties of the licenseholder in question, and the time for appeal has elapsed or the judgment of conviction has been affirmed on appeal, irrespective of an order granting probation following the conviction, suspending the imposition of sentence, or of a subsequent order under Section 1203.4 of the Penal Code allowing the person to withdraw a plea of guilty and to enter a plea of not guilty,

or setting aside the plea or verdict of guilty, or dismissing the accusation or information.

Added Stats 1991 ch 386 § 11 (SB 290). Amended Stats 2009 ch 307 § 102 (SB 821), effective January 1, 2010.

#### § 44072.2. Grounds for suspension, revocation, or disciplinary action against license

The director may suspend, revoke, or take other disciplinary action against a license as provided in this article if the licensee, or any partner, officer, or director thereof, does any of the following:

(a) Violates any section of this chapter and the regulations adopted pursuant to it, which related to the licensed activities.

(b) Is convicted of any crime substantially related to the qualifications, functions, or duties of the licenseholder in question.

(c) Violates any of the regulations adopted by the director pursuant to this chapter.

(d) Commits any act involving dishonesty, fraud, or deceit whereby another is injured.

(e) Has misrepresented a material fact in obtaining a license.

(f) Aids or abets unlicensed persons to evade the provisions of this chapter.

(g) Fails to make and keep records showing his or her transactions as a licensee, or fails to have those records available for inspection by the director or his or her duly authorized representative for a period of not less than three years after completion of any transaction to which the records refer, or refuses to comply with a written request of the director to make the records available for inspection.

(h) Violates or attempts to violate the provisions of this chapter relating to the particular activity for which he or she is licensed.

Added Stats 1991 ch 386 § 11 (SB 290). Amended Stats 2009 ch 307 § 103 (SB 821), effective January 1, 2010.

#### § 44072.3. What constitutes conviction

A plea or verdict of guilty or a conviction following a plea of nolo contendere is a conviction within the meaning of this article. The director may order the license suspended or revoked or may decline to issue a license, when the time for appeal has elapsed, or the judgment of conviction has been affirmed on appeal, or when an order granting probation is made suspending the imposition of sentence irrespective of a subsequent order under Section 1203.4 of the Penal Code allowing the person to withdraw a plea of guilty and to enter a plea of not guilty, or setting aside the verdict of guilty, or dismissing the accusation, information, or indictment.

Added Stats 1991 ch 386 § 11 (SB 290).

#### § 44072.4. Types of disciplinary action

The director may take disciplinary action against any licensee after a hearing as provided in this article by any of the following:

(a) Imposing probation upon terms and conditions to be set forth by the director.

(b) Suspending the license.

(c) Revoking the license.

Added Stats 1991 ch 386 § 11 (SB 290).

**§ 44072.5. Surrender of license**

Upon the effective date of any order of suspension or revocation of any license governed by this chapter, the licensee shall surrender the license to the director.

Added Stats 1991 ch 386 § 11 (SB 290).

**§ 44072.6. Jurisdiction to proceed with investigation of or action against licensee**

The expiration or suspension of a license by operation of law or by order or decision of the director or a court of law, or the voluntary surrender of a license by a licensee shall not deprive the director of jurisdiction to proceed with any investigation of, or action or disciplinary proceedings against, the licensee, or to render a decision suspending or revoking the license.

Added Stats 1991 ch 386 § 11 (SB 290).

**§ 44072.7. Limitations period**

All accusations against licensees shall be filed within three years after the act or omission alleged as the ground for disciplinary action, except that with respect to an accusation alleging a violation of subdivision (d) of Section 44072.2, the accusation may be filed within two years after the discovery by the bureau of the alleged facts constituting the fraud or misrepresentation prohibited by that section.

Added Stats 1991 ch 386 § 11 (SB 290). Amended Stats 2001 ch 357 § 5 (AB 1560).

**§ 44072.8. Revocation or suspension of additional license**

When a license has been revoked or suspended following a hearing under this article, any additional license issued under this chapter in the name of the licensee may be likewise revoked or suspended by the director.

Added Stats 1991 ch 386 § 11 (SB 290).

**§ 44072.9. Reinstatement of license**

After suspension of the license upon any of the grounds set forth in this article, the director may reinstate the license upon proof of compliance by the applicant with all provisions of the decision as to reinstatement. After revocation of a license upon any of the grounds set forth in this article, the license shall not be reinstated or reissued within a period of one year after the effective date of revocation.

Added Stats 1991 ch 386 § 11 (SB 290).

**§ 44072.10. Temporary suspension of license; Grounds; Fraudulent certification; Hearing and notice**

(a) Notwithstanding Sections 44072 and 44072.4, the director, or the director's designee, pending a hearing conducted pursuant to subdivision (e), may temporarily suspend any smog check station or technician's license issued under this chapter, for a period not to exceed 60 days, if the department determines that the licensee's conduct would endanger the public health, safety, or welfare before the matter could be heard pursuant to subdivision (e), based upon reasonable evidence of any of the following:

- (1) Fraud.
- (2) Tampering.

(3) Intentional or willful violation of this chapter or any regulation, standard, or procedure of the department implementing this chapter.

(4) A pattern or regular practice of violating this chapter or any regulation, standard, or procedure of the department implementing this chapter.

(b) If a motor vehicle dealer sells any used vehicle, knowing that the vehicle has been fraudulently certified, that act shall be additional grounds for suspension or revocation pursuant to Section 11705 of the Vehicle Code. A dealer's license revoked pursuant to this subdivision shall not be reinstated for any reason for a period of at least five years.

(c) The department shall revoke the license of any smog check technician or station licensee who fraudulently certifies vehicles or participates in the fraudulent inspection of vehicles. A fraudulent inspection includes, but is not limited to, all of the following:

- (1) Clean piping, as defined by the department.
- (2) Tampering with a vehicle emission control system or test analyzer system.
- (3) Tampering with a vehicle in a manner that would cause the vehicle to falsely pass or falsely fail an inspection.

(4) Intentional or willful violation of this chapter or any regulation, standard, or procedure of the department implementing this chapter.

(d) Once a license has been revoked for a smog check station or technician under subdivision (a) or (c), the license shall not be reinstated for any reason. A hearing shall be held and a decision issued within 60 days after the date on which the notice of the temporary suspension was provided unless the time for the hearing has been extended, or the right to a hearing has been waived, by the licensee.

(e) The hearing shall be conducted in accordance with Chapter 5 (commencing with Section 11500) of Part 1 of Division 3 of Title 2 of the Government Code, or by court order.

(f) The department shall adopt, by regulation, procedures to ensure that any affected licensee is provided adequate notice and opportunity to be heard, except as otherwise provided in subdivision (a), prior to issuing an order temporarily suspending a license under this section.

Added Stats 1994 ch 27 § 52 (AB 2018), effective March 30, 1994. Amended Stats 2001 ch 357 § 6 (AB 1560).

**§ 44072.11. Refusal to issue or renew license; Revocation or suspension of license**

(a) The department may refuse to issue or renew a license for a smog check station or technician who is subject to a 60-day suspension pursuant to Section 44072.10.

(b) Any smog check station or technician's license granted by the department is a privilege and not a vested right, and may be revoked or suspended by the department for any of the reasons specified in Section 44072.1 or on evidence that the station or technician is not in compliance with any of the requirements of subdivision (a).

Added Stats 1994 ch 27 § 53 (AB 2018), effective March 30, 1994.

## ARTICLE 8

### Gross Polluters

#### Section

44080. Legislative findings and declarations  
 44081. Identification of gross polluters  
 44081.6. Pilot demonstration program regarding emissions  
 44084. Gross polluters whose emissions could be reduced by repair;  
     Financial incentives  
 44085. Marketable emission reduction credits  
 44086. Cost effectiveness of programs

#### § 44080. Legislative findings and declarations

The Legislature finds and declares as follows:

- (a) California's air is the most polluted in the nation and the largest source of that pollution is automobiles.
- (b) California has the most stringent new car emission standards in the nation as well as a vehicle inspection (smog check) program that result in most cars producing very little pollution.
- (c) A small percentage of automobiles cause a disproportionate and significant amount of the air pollution in California.
- (d) These gross polluters are primarily vehicles in which the emission control equipment has been disconnected or which are very poorly maintained.
- (e) New technologies, such as remote sensing, can identify gross polluters on the roads, enabling law enforcement authorities to stop, inspect, and cite vehicles with disconnected emission control equipment, and can promote the development of incentives for the repair of other high-emitting vehicles.
- (f) Requiring owners to reconnect emission control equipment and developing incentives for needed maintenance on high-emitting vehicles may be cost-effective methods to reduce emissions and help achieve air quality standards in many districts.

Added Stats 1992 ch 972 § 1 (SB 1404).

#### § 44081. Identification of gross polluters

(a)(1) The department, in cooperation with the state board, shall institute procedures for auditing the emissions of vehicles while actually being driven on the streets and highways of the state. The department may undertake those procedures itself or seek a qualified vendor of these services. The primary object of the procedures shall be the detection of gross polluters. The procedures shall consist of techniques and technologies determined to be effective for that purpose by the department, including, but not limited to, remote sensing. The procedures may include pullovers for roadside emissions testing and inspection. The department shall consider the recommendations of the review committee based on the outcome of the pilot demonstration program conducted pursuant to Section 44081.6.

(2) The department may additionally use other methods to identify gross polluting vehicles for out-of-cycle testing and repair.

(b) The department shall, by regulation, establish a program for the out-of-cycle testing and repair of motor vehicles found, through roadside auditing, to be emitting at levels that exceed specified standards. The program shall include all of the following elements:

(1) Emission standards, and test and inspection procedures and regulations, adopted in coordination with

the state board, applicable to vehicles tested during roadside auditing. Emission standards for issuance of a notice of noncompliance to a gross polluter shall be designed to maximize the identification of vehicles with substantial excess emissions.

(2) Procedures for issuing notices of noncompliance to owners of gross polluters, either at the time of the roadside audit, or subsequently by certified mail, or by obtaining a certificate of mailing as evidence of service, using technologies for recording license plate numbers. The notice of noncompliance shall provide that, unless the vehicle is brought to a designated test-only facility or a test-and-repair station that is both licensed and certified pursuant to Sections 44014 and 44014.2, for emissions testing within 30 days, the owner is required to pay an administrative fee of five hundred dollars (\$500) to be collected by the Department of Motor Vehicles at the next annual registration renewal or the next change of ownership of the vehicle, whichever occurs first. Commencing on the 31st day after issuance of the notice of noncompliance, the fee shall accrue at the rate of five dollars (\$5) per day up to the five hundred dollars (\$500) maximum.

(3) Procedures for the testing of vehicles identified as gross polluters by a designated test-only facility, or a test-and-repair station that is both licensed and certified pursuant to Sections 44014 and 44014.2, to confirm that the vehicle exceeds the minimum emission standard for gross polluters set by the department.

(4) Procedures requiring owners of vehicles confirmed as gross polluters to have the vehicle repaired, resubmitted for testing, and obtain a certificate of compliance from a designated test-only facility, or a test-and-repair station that is both licensed and certified pursuant to Sections 44014 and 44014.2, or removed from service as attested by a certificate of nonoperation from the Department of Motor Vehicles within 30 days or be required to pay an administrative fee of not more than five hundred dollars (\$500), to be collected by the Department of Motor Vehicles at the next annual registration renewal or the next change of ownership, whichever occurs first. Commencing on the 31st day after issuance of the notice of noncompliance, the fee shall accrue at the rate of five dollars (\$5) per day up to the five hundred dollar (\$500) maximum. The registration of a vehicle shall not be issued or renewed if that vehicle has been identified as a gross polluter and has not been issued a certificate of compliance. Except as provided in subdivision (b) of Section 9250.18 of the Vehicle Code, any revenues collected by the Department of Motor Vehicles pursuant to this subdivision and Section 9250.18 of the Vehicle Code shall be deposited in the Vehicle Inspection and Repair Fund. If the ownership of the vehicle is transferred, the administrative fee provided for in this subdivision shall be waived if the vehicle is brought into compliance.

(5) A procedure for notifying the Department of Motor Vehicles of notices of noncompliance issued, so that the Department of Motor Vehicles may provide effective collection of the administrative fee. The Department of Motor Vehicles shall cooperate with, and implement the requirements of, the department in that regard.

(c) The department may adopt any other regulations necessary for the effective implementation of this section, as determined by the department.

(d) Upon the request of the department, the Department of the California Highway Patrol shall provide assistance in conducting roadside auditing, to consist of (1) the stopping of vehicles and traffic management, and (2) the issuance of notices of noncompliance to gross polluters. The department shall reimburse the Department of the California Highway Patrol for its costs of providing those services. The Department of Transportation and affected local agencies shall provide necessary assistance and cooperation to the department in the operation of the program.

(e) There shall be no repair cost limit imposed pursuant to Section 44017 for any repairs that are required to be made under the roadside auditing program, except as provided in Section 44017.

(f) This section does not apply to vehicles operating under a valid repair cost waiver or economic hardship extension issued pursuant to Section 44015.

Added Stats 1994 ch 27 § 55 (AB 2018), effective March 30, 1994. Amended Stats 1994 ch 1220 § 15.7 (AB 3132), effective September 30, 1994; Stats 1996 ch 1088 § 11 (AB 2515), effective September 30, 1996; Stats 1997 ch 17 § 82 (SB 947), ch 802 § 7 (AB 208) (ch 802 prevails); Stats 2002 ch 1001 § 7 (AB 2637).

#### § 44081.6. Pilot demonstration program regarding emissions

(a) The California Environmental Protection Agency, the state board, and the department, in cooperation with, and with the participation of, the Environmental Protection Agency, shall jointly undertake a pilot demonstration program to do all of the following:

(1) Determine the emission reduction effectiveness of alternative loaded mode emission tests compared to the IM240 test.

(2) Quantify the emission reductions, above and beyond those required by Environmental Protection Agency regulation or by the biennial test requirement, achievable from a remote sensing-based program that identifies gross polluting and other vehicles and requires the immediate repair and retest of those gross polluting vehicles at a test-only station established by this chapter.

(3) Determine if high polluting vehicles can be identified and directed to test-only stations using criteria other than, or in addition to, age and model year, and whether this reduces the number of vehicles which would otherwise be subject to inspection at test-only stations.

(4) Qualify emission reductions above and beyond those that are required by the regulations of the Environmental Protection Agency, achievable from other program enhancements pursuant to this chapter.

(5) Determine the extent to which the capacity of the test-only station network established pursuant to Section 44010.5 needs to be expanded to comply with Environmental Protection Agency performance standards.

(b) The California Environmental Protection Agency shall enter into a memorandum of agreement with the Environmental Protection Agency to establish the protocol for the pilot demonstration program. The memorandum of agreement shall ensure, to the extent possible, that the Environmental Protection Agency will accept the results of the pilot demonstration program as the findings of the Administrator of the Environmental Protection Agency.

The pilot demonstration program shall be conducted pursuant to the memorandum of agreement.

(c) The review committee established pursuant to Section 44021 shall review the protocol for the pilot demonstration program, as established in the signed memorandum of agreement, and recommend any modification that the review committee finds to be appropriate for the pilot demonstration program. Any such modification shall become effective only upon the written agreement of the California Environmental Protection Agency and the Environmental Protection Agency.

(d) The department shall contract, on behalf of the committee, with an independent entity to ensure quality control in the collection of data pursuant to the pilot demonstration program. The department shall also contract, on behalf of the committee, for an independent analysis of the data produced by the pilot demonstration program.

(e) Any contract entered into pursuant to this section shall not be subject to any restrictions that are applicable to contracts in the Government Code or in the Public Contract Code.

(f) To the extent possible, the pilot demonstration program shall be conducted using equipment, facilities, and staff of the state board, the department, and the Environmental Protection Agency.

(g) The pilot demonstration program shall provide for, but not be limited to, all of the following:

(1) For the purposes of this section, any vehicle subject to the inspection and maintenance program may be selected to participate in the pilot demonstration program regardless of when last inspected pursuant to this chapter.

(2) Registered owners of vehicles selected to participate in the pilot demonstration program shall make the vehicle available for testing within a time period and at a testing facility designated by the department. If necessary, the department shall increase the capacity of the existing referee network in the area or areas where the pilot demonstration program will be operating, in order to accommodate the convenient testing of selected vehicles.

(3) If the department finds that a vehicle is emitting excessive emissions, the vehicle owner shall be required to make necessary repairs within the existing cost limits and return to a testing facility designated by the department. The vehicle owner shall have additional repairs made if the repairs are requested and funded by the department. The department shall also fund the cost of any necessary repairs if the owner of the vehicle has, within the last two years, already paid for emissions-related repairs to the same vehicle in an amount at least equal to the existing cost limits, in order to obtain a certificate of compliance or an emission cost waiver.

(4) Vehicle owners who fail to bring the vehicle in for inspection or fail to have repairs made pursuant to this section shall be issued notices of noncompliance. The notice shall provide that, unless the vehicle is brought to a designated testing facility for testing, or repair facility for repairs, within 15 days of notice of the requirement, the owner will be required to pay an administrative fee of not more than five dollars (\$5) a day, not to exceed two hundred fifty dollars (\$250), to be collected by the Department of the California Highway Patrol.

partment of Motor Vehicles at the next annual registration renewal or the next change of ownership of the vehicle, whichever occurs first. Commencing on the 31st day after issuance of the notice of noncompliance, the fee shall accrue at the rate of five dollars (\$5) per day up to the two hundred fifty dollars (\$250) maximum. Except as provided in subdivision (b) of Section 9250.18 of the Vehicle Code, any revenues collected by the Department of Motor Vehicles pursuant to this subdivision and Section 9250.18 of the Vehicle Code shall be deposited into the Vehicle Inspection and Repair Fund by the Department of Motor Vehicles.

(h) The Department of Motor Vehicles, the Department of Transportation, local agencies, and the state board shall provide necessary support for the program established pursuant to this section.

(i) As soon as possible after the effective date of this section, the department and the state board shall develop, implement, and revise as needed, emissions test procedures and emissions standards necessary to conduct the pilot demonstration program.

Added Stats 1994 ch 27 § 56 (AB 2018), effective March 30, 1994. Amended Stats 1994 ch 1220 § 16 (AB 3132), effective September 30, 1994; Stats 2012 ch 728 § 94 (SB 71), effective January 1, 2013.

#### § 44084. Gross polluters whose emissions could be reduced by repair; Financial incentives

In addition to other programs authorized in this article, a district may, on or after March 1, 1993, establish programs to identify gross polluters and other high-emitting vehicles whose emissions could be reduced by repair, using remote sensors or other methods, and to provide financial incentives to encourage the repair or scrapping of these vehicles as a method of reducing mobile source emissions for the purposes of Section 40914. The programs authorized by this section are not intended to impose additional emission reduction requirements, but instead are intended to provide more cost-effective alternative methods to meet existing requirements.

Added Stats 1992 ch 972 § 1 (SB 1404).

#### § 44085. Marketable emission reduction credits

Districts may establish procedures to generate marketable emission reduction credits from programs established pursuant to Section 44084. Emission reduction credits generated pursuant to this section may be used to meet or offset transportation control requirements, average vehicle ridership reductions, or other mobile source emission requirements, as determined by the district.

Added Stats 1992 ch 972 § 1 (SB 1404). Amended Stats 1996 ch 124 § 75 (AB 3470).

#### § 44086. Cost effectiveness of programs

Each district shall, in establishing, reviewing, or updating the plan required by Chapter 10 (commencing with Section 40910) of Part 3, consider the relative cost-effectiveness of the programs authorized in this article compared to other control measures under consideration.

Added Stats 1992 ch 972 § 1 (SB 1404).

## ARTICLE 9

### Repair or Removal of High Polluters

#### Section

#### 44090. Definitions

44091. High Polluter Repair or Removal Account; Source of funds; Reserves; Use of funds

44091.1. Increase in smog abatement fee for certain exempt vehicles if smog impact fee is uncollectible; Allocation of revenues

44091.2. Intent as to impact fee

44092. High polluter repair or removal program

44093. Repair of high polluters

44094. Participation in high polluter repair or removal program; Contents of program

44095. Administration of program

44096. Cost-effectiveness of emissions reduction devices for light-duty vehicles

44099. [Section repealed 2014.]

#### § 44090. Definitions

For purposes of this article, the following terms have the following meanings:

(a) "Account" means the High Polluter Repair or Removal Account created pursuant to subdivision (a) of Section 44091.

(b) "High polluter" means a high-emission motor vehicle, including, but not limited to, a gross polluter.

Added Stats 1994 ch 28 § 2 (SB 198), effective March 30, 1994. Amended Stats 2006 ch 538 § 406 (SB 1852), effective January 1, 2007.

#### § 44091. High Polluter Repair or Removal Account; Source of funds; Reserves; Use of funds

(a) The High Polluter Repair or Removal Account is hereby created in the Vehicle Inspection and Repair Fund. All money deposited in the account pursuant to this article shall be available, upon appropriation by the Legislature, to the department and the state board to establish and implement a program for the repair or replacement of high polluters pursuant to Section 44062.1 and Article 10 (commencing with Section 44100).

(b) The department may accept donations or grants of funds from any person for purposes of the program and shall deposit that money in the account. Donations, grants, or other commitments of money to the account may be dedicated for specific purposes consistent with the uses of the account, including, but not limited to, purchasing higher emitting vehicles for the purpose of achieving the emission reductions required by the M-1 strategy of the 1994 State Implementation Plan (SIP).

(c) The funds which are available in the account in any fiscal year for a particular area that is subject to an inspection and maintenance program shall be distributed to reflect the number of vehicles registered in that area to the total number of vehicles registered in areas that are subject to inspection and maintenance programs. That percentage shall be the percentage of the total funds allocated to the program in that fiscal year which are available for that particular area.

(d) It is the intent of the Legislature that a prudent amount be determined to retain as a reserve in the Vehicle Inspection and Repair Fund, and that any moneys in the fund above that amount be transferred to the High Polluter Repair or Removal Account. It is also the intent of the Legislature that those transferred moneys be available, upon appropriation by the Legislature, for

expenditure by the department to support the programs described in this section.

(e) During any fiscal year, the money in the account shall be available, upon appropriation by the Legislature, for the following purposes:

(1) Assistance in the repair of high polluters pursuant to the program established pursuant to Section 44062.1.

(2) Voluntary accelerated retirement of high polluters.

(3) Rulemaking, vehicle testing, and other technical work required to implement and administer the repair assistance program established pursuant to Section 44062.1 and the program described in Article 10 (commencing with Section 44100).

(f) An amount of one million dollars (\$1,000,000) annually for the 1997–98 fiscal year and the 1998–99 fiscal year shall be made available from the account for a program to evaluate the emission reduction effectiveness of the M-1 strategy of the 1994 SIP.

(g) All remaining amounts in the account shall be available to the program of repair assistance established pursuant to Section 44062.1.

(h) In no case shall the funding available in any subsequent fiscal year to the department for repairing or removing high-emitting vehicles under the inspection and maintenance program be less than the amount made available from the Vehicle Inspection and Repair Fund for that purpose in the 1995–96 fiscal year.

Added Stats 1994 ch 28 § 2 (SB 198), effective March 30, 1994. Amended Stats 1995 ch 929 § 4 (SB 501); Stats 1997 ch 802 § 8 (AB 208); Stats 2004 ch 230 § 9 (SB 1107), effective August 16, 2004.

**§ 44091.1. Increase in smog abatement fee for certain exempt vehicles if smog impact fee is uncollectible; Allocation of revenues**

Commencing January 1, 2005, the fee specified in paragraph (1) of subdivision (d) of Section 44060 shall be twelve dollars (\$12). The revenues from that fee shall be allocated as follows:

(a) The revenues generated by six dollars (\$6) of the fee shall be deposited in the Air Pollution Control Fund, and shall be available for expenditure, upon appropriation by the Legislature, to fund the Carl Moyer Memorial Air Quality Standards Attainment Program (Chapter 9 (commencing with Section 44275)) to the extent that the state board or a participating district determines the moneys are expended to mitigate or remediate the harm caused by the type of motor vehicle on which the fee is imposed.

(b)(1) Except as provided for in paragraph (2), of the revenue generated by the remaining six dollars (\$6) of the fee, four dollars (\$4) shall be deposited in the account created by Section 44091, while the revenue generated by the remaining two dollars (\$2) shall be deposited in the Vehicle Inspection and Repair Fund.

(2) All revenue generated by the remaining six dollars (\$6) of the fee described in this subdivision that is imposed at first registration of a motor vehicle and that is exempted under paragraph (4) of subdivision (a) of Section 44011 shall be deposited in the account created by Section 44091.

Added Stats 2004 ch 702 § 9 (AB 2104), effective September 23, 2004, operative January 1, 2005. Amended Stats 2004 ch 703 § 1 (AB 2128).

**§ 44091.2. Intent as to impact fee**

It is the intent of the Legislature that if the impact fee imposed pursuant to Section 6262 of the Revenue and

Taxation Code is ruled unconstitutional by an appellate court or the California Supreme Court, or if the state is in any manner prevented by either of those courts from imposing or collecting the fee, the repair assistance program implemented pursuant to Section 44062.1 and any voluntary vehicle retirement program implemented by the department not be supported by money appropriated from the General Fund.

Added Stats 1999 ch 67 § 17 (AB 1105), effective July 6, 1999.

**§ 44092. High polluter repair or removal program**

The high-polluter repair or removal program shall be designed to repair or remove motor vehicles registered in this state that are subject to an inspection and maintenance program and are producing high levels of emissions as a result of their use in this state

Added Stats 1994 ch 28 § 2 (SB 198), effective March 30, 1994. Amended Stats 1995 ch 929 § 5 (SB 501).

**§ 44093. Repair of high polluters**

The repair of high polluters under the program shall be designed to offer repair cost assistance to qualified low-income motor vehicle owners for vehicles that are in need of repairs to obtain a certificate of compliance, as determined by the department.

Added Stats 1994 ch 28 § 2 (SB 198), effective March 30, 1994. Amended Stats 1995 ch 91 § 94 (SB 975).

**§ 44094. Participation in high polluter repair or removal program; Contents of program**

(a) Participation in the high polluter repair or removal program specified in this article and Article 10 (commencing with Section 44100) shall be voluntary and shall be available to the owners of high polluters that are registered in an area that is subject to an inspection and maintenance program, have been registered for at least 24 months in the district where the credits are to be applied and, are presently operational, and meet other criteria, as determined by the department.

(b) The program shall provide for both of the following:

(1) As to the repair of a high polluter, payment to the owner of up to 80 percent of the total cost of repair, as determined by the department, but the payment shall not exceed four hundred fifty dollars (\$450).

(2) As to the removal of a high polluter, the program shall be subject to Article 10 (commencing with Section 44100).

(c) Except as provided in Section 44062.3, the department may specify the amount of money that may be paid to an owner of a high-polluting motor vehicle who voluntarily retires the vehicle. The amount paid by the department shall be based on the cost-effectiveness and the air quality benefit of retiring the vehicle, as determined by the department.

(d) The department may authorize participation in the program based on a reasonable estimate of the future revenues that will be available to the program.

Added Stats 1994 ch 28 § 2 (SB 198), effective March 30, 1994. Amended Stats 1995 ch 929 § 6 (SB 501); Stats 1999 ch 67 § 18 (AB 1105), effective July 6, 1999; Stats 2006 ch 761 § 6 (AB 1870), effective January 1, 2007.

**§ 44095. Administration of program**

(a) The department shall administer the program in accordance with regulations adopted by the department.

(b)(1) Nothing in this article shall be construed as superseding or precluding any similar program that is administered by a district, any other public agency, or any other person.

(2) The state board shall develop a methodology for, and shall undertake, a uniform data analysis of the program operated pursuant to this article and any similar programs operated in this state for the purpose of providing an accounting of the emission reductions that are achieved by all such programs.

(c) The department may directly operate the program or may provide for the program's operation pursuant to an agreement. The department may enter into an agreement with local agencies, community colleges, air quality management districts, or private entities to perform all or any portion of the program.

Added Stats 1994 ch 28 § 2 (SB 198), effective March 30, 1994. Amended Stats 2009 ch 307 § 104 (SB 821), effective January 1, 2010.

#### § 44096. Cost-effectiveness of emissions reduction devices for light-duty vehicles

(a) The state board shall review and assess the potential cost-effectiveness, in terms of dollars per ton of emissions reduced, of emissions reduction devices that are intended for installation in light-duty motor vehicles and meet the qualifications specified in subdivision (b). The results of the assessment shall be made available to the department and the districts, and shall be considered by the state board in determining whether an emissions reduction device is a cost-effective means of emissions reduction, as compared with the accelerated light-duty vehicle retirement program conducted pursuant to Article 10 (commencing with Section 44100) and any other vehicle retirement program authorized by the department or the districts.

(b) The state board shall perform the review and assessment specified in subdivision (a) only for an emission reduction device that meets at least one of the following qualifications:

(1) The device has received a certification under the California Environmental Technology Certification Program.

(2) The device has received accreditation under the state board's "Criteria and Test Procedures for Accrediting Emission Control Devices" (ARB "B" Designation) pursuant to Section 43630.

Added Stats 1999 ch 209 § 1 (SB 1056).

#### § 44099. [Section repealed 2014.]

Added Stats 2007 ch 634 § 1 (SB 23), effective January 1, 2008, repealed January 1, 2013. Amended Stats 2011 ch 494 § 1 (SB 570), effective January 1, 2012. The repealed section related to donated vehicles; voluntary program to improve air quality.

## ARTICLE 10

### Accelerated Light-Duty Vehicle Retirement Program

#### Section

44100. Legislative findings and declarations

44101. Statewide program

44102. Coordination of requirements and implementation by state agencies

44103. Objectives of program

#### Section

44104. Funding for program

44104.5. Plan for first two years of program; Progress report

44105. State oversight agency

44106. Provisions for tampering and fraud

44107. Discouragement of tampering and fraud

44109. Solicitation of vehicle owners

44115. Convenience of vehicle purchase transactions

44120. Vehicle disposal

44121. Standards for certification and use of emission reduction credits

44122. Measurement of emission reductions

#### § 44100. Legislative findings and declarations

The Legislature hereby finds and declares as follows:

(a) Emission reduction programs based on market principles have the potential to provide equivalent or superior environmental benefits when compared to existing controls at a lower cost to the citizens of California than traditional emission control requirements.

(b) Several studies have demonstrated that a small percentage of light-duty vehicles contribute disproportionately to the on-road emissions inventory. Programs to reduce or eliminate these excess emissions can significantly contribute to the attainment of the state's air quality goals.

(c) Programs to accelerate fleet turnover can enhance the effectiveness of the state's new motor vehicle standards by bringing more low-emission vehicles into the on-road fleet earlier.

(d) The California State Implementation Plan for Ozone (SIP), adopted November 15, 1994, and submitted to the Environmental Protection Agency, calls for added reductions in reactive organic gases (ROG) and oxides of nitrogen (NO<sub>x</sub>) from light-duty vehicles by the year 2010. One of the more market-oriented approaches reflected in the SIP, known as the M-1 strategy, calls for accelerating the retirement of older light-duty vehicles in the South Coast Air Quality Management District to achieve the following emission reductions:

Year	Emissions, TPD (tons per day) (ROG + NO <sub>x</sub> )
1999	9
2002	14
2005	20
2007	22
2010	25

(e) A program for achieving those and more emission reductions should be based on the following principles:

(1) If the program receives adequate funding, the first two years should include a thorough assessment of the costs and short-term and long-term emission reduction benefits of the program, compared with other emission reduction programs for light-duty vehicles, which shall be reflected in recommendations by the state board to the Governor and the Legislature on strategies and funding needs for meeting the emission reduction requirements of the M-1 strategy of the 1994 SIP for the years 1999 to 2010, inclusive.

(2) The program should first contribute to the achievement of the emission reductions required by the inspection and maintenance program and the M-1 strategy of the 1994 SIP, and should permit the use of mobile source emission reduction credits for other purposes currently authorized by the state board or a district. Remaining credits may be used to achieve other emission reduc-

tions, including those required by the 1994 SIP, in a manner consistent with market-based strategies. Emission credits shall not be used to offset emission standards or other requirements for new vehicles, except as authorized by the state board.

(3) Participation by the vehicle owner shall be entirely voluntary and the program design should be sensitive to the concerns of car collectors and to consumers for whom older vehicles provide affordable transportation.

(4) The program design shall provide for real, surplus, and quantifiable emission reductions, based on an evaluation of the purchased vehicles, taking into account factors that include per-mile emissions, annual miles driven, remaining useful life of retired vehicles, and emissions of the typical or average replacement vehicle, as determined by the state board. The program shall ensure that there is no double counting of emission credits among the various vehicle removal programs.

(5) The program should specify the emission reductions required and then utilize the market to ensure that these reductions are obtained at the lowest cost.

(6) The program should be privately operated. It should utilize the experience and expertise gained from past successful programs. Existing entities that are authorized by, contracted with, or otherwise sanctioned by a district and approved by the state board and the United States Environmental Protection Agency shall be fully utilized for purposes of implementing this article. Nothing in this paragraph restricts the Department of Consumer Affairs from selecting qualified contractors to operate or administer any program specified pursuant to this chapter.

(7) The program should be designed insofar as possible to eliminate any benefit to any participants from vehicle tampering and other forms of cheating. To the extent that tampering and other forms of cheating might be advantageous, the program design shall include provisions for monitoring the occurrence of tampering and other forms of cheating.

(8) Emission credits should be expressed in pounds or other units, and their value should be set by the marketplace. Any contract between a public entity and a private party for the purchase of emission credits should be based on a price per pound which reflects the market value of the credit at its time of purchase. Emission reductions required by the M-1 and other strategies of the 1994 SIP shall be accomplished by competitive bid among private businesses solicited by the oversight agency designated pursuant to Section 44105.

Added Stats 1995 ch 929 § 7 (SB 501). Amended Stats 2004 ch 644 § 22 (AB 2701); Stats 2012 ch 728 § 95 (SB 71), effective January 1, 2013.

#### § 44101. Statewide program

Not later than December 31, 1998, the state board shall adopt, by regulation, a statewide program to commence in 1999 that does all of the following:

(a) Provides for the creation, exchange, use, and retirement of light-duty vehicle mobile source emission reduction credits. The credits shall be fungible and exchangeable in the marketplace, and shall reflect the actual emissions of the vehicles that are retired or otherwise disposed of, by measurement, appropriate sampling, or correlations developed from appropriate

sampling. The numerical value of credits may be constant over a defined lifetime, or may decline with age measured from the time of origination of the credits. In all cases, the numerical value of the credits shall reflect the useful life expectancies and the projected in-use emissions of the retired vehicles in a manner consistent with the assumptions used in determining the emissions inventory. The credits shall be fully recognized by the United States Environmental Protection Agency, the state board, and the districts.

(b) Sets out the criteria for retiring or otherwise disposing of high-emitting vehicles purchased for this program.

(c) Authorizes the issuance of those credits to private entities that purchase and properly retire high-emitting vehicles.

(d) Authorizes the resale of those credits to public or private entities to be used to achieve the emission reduction requirements of the 1994 state implementation plan, meet the requirements of the inspection and maintenance program, satisfy compliance with other emission reduction mandates, as determined by the district or the state board, create local growth allowances, or satisfy new or modified source emission offset requirements. Nothing in this article limits a district's authority to apply emission discount factors pursuant to district rules that regulate emissions banks, trades, or offsets.

(e) Provides for the retirement of those credits when used.

(f) Includes accounting procedures to credit emissions reductions achieved through vehicle scrappage to the M-1 strategy of the 1994 SIP and the inspection and maintenance program.

(g) Contains a program plan pursuant to Section 44104.5.

(h) Satisfies the attributes described in subdivision (e) of Section 44100.

Added Stats 1995 ch 929 § 7 (SB 501). Amended Stats 1997 ch 802 § 10 (AB 208).

#### § 44102. Coordination of requirements and implementation by state agencies

(a) The state board, the Department of Motor Vehicles, and the department shall harmonize the requirements and implementation of this program with the motor vehicle inspection program and other programs contained in this chapter, particularly the provisions relating to gross polluters in Article 8 (commencing with Section 44080) and the repair or removal of high polluters in Article 9 (commencing with Section 44090).

(b) Insofar as practicable, these programs shall be seamless to the participants and the public.

Added Stats 1995 ch 929 § 7 (SB 501).

#### § 44103. Objectives of program

Notwithstanding any other provision of law, the program shall also do both of the following:

(a) Authorize the Department of Motor Vehicles, at the request of persons engaged in the purchase and retirement of vehicles under the program, to send notices to vehicle owners who are candidates for the sale of vehicles under the program describing the opportunity to participate in the program. The Department of Motor



Vehicles may recover all costs of those notifications from the requesting party or parties.

(b) Allow the issuance of nonrevivable junk certificates for vehicles retired under the program, which shall allow program vehicles to be scrapped only for parts, except those parts identified pursuant to subdivision (a) of Section 44120.

Added Stats 1995 ch 929 § 7 (SB 501). Amended Stats 1996 ch 1088 § 12 (AB 2515), effective September 30, 1996.

#### § 44104. Funding for program

(a) Funds shall be available to the state board from the High Polluter Repair or Removal Account created pursuant to subdivision (a) of Section 44091. Those funds shall be used to perform the rulemaking, vehicle testing, and other technical work necessary to achieve the objectives set forth in Sections 44101 and 44104.5. Those administrative expenditures shall not exceed a total of three million dollars (\$3,000,000) over the first three years of the program.

(b) Funds available to the state board pursuant to paragraph (1) of subdivision (d) of Section 44091 shall be used to purchase and retire mobile source emission reduction credits resulting from the retirement of light-duty vehicles pursuant to this article for the purpose of achieving the emission reductions required by the M-1 strategy of the 1994 SIP. If offers from authorized private scrapping entities are deemed, by the department, consistent with the criteria set forth in Section 44101, to be noncompetitive in cost-effectiveness, in terms of dollars per ton of emissions reduced, the department shall directly purchase vehicles from owners in order to achieve the greatest reduction in emissions at the least cost. If these purchases, in turn, are deemed by the department to be not cost-competitive, in terms of dollars per ton of emissions reduced, with other strategies identified by the state board, the department shall use the funds to pursue other more cost-effective strategies identified by the state board. All emission reduction credits purchased with the funds described in this paragraph shall be retired and credited to the M-1 strategy of the 1994 SIP.

(c) This article shall not create an obligation on the part of any state or local agency to expend money, incur substantial administrative costs, or purchase credits to meet the M-1 requirements of the 1994 State Implementation Plan until the Director of Finance certifies that there are sufficient funds in the High Polluter Repair or Removal Account for purposes of the article.

(d) This article shall not create an obligation to use existing funds that are currently used to meet other air quality mandates, including funds collected pursuant to Sections 44223, 44225, 44227, and 44243, for purchasing credits to satisfy the M-1 or other strategies of the 1994 SIP.

(e) The state board and the department shall seek federal funds to be deposited in the High Polluter Repair or Removal Account, and shall explore the availability of other funding sources, such as private contributions, the Petroleum Violation Escrow Account, and proceeds from fees, fines, or other penalties resulting from fuel specification violations.

Added Stats 1995 ch 929 § 7 (SB 501).

#### § 44104.5. Plan for first two years of program; Progress report

(a) The regulations adopted pursuant to subdivision (a) of Section 44101 shall include a plan to guide the execution of the first two years of the program, to assess the results, and to formulate recommendations. The plan shall also verify whether the light-duty vehicle scrapping program included in the state implementation plan adopted on November 15, 1994, can reasonably be expected to yield the required emissions reductions at reasonable cost-effectiveness. Scrapping of any vehicles under this program for program development or testing or for generating emission reductions to be credited against the M-1 strategy of the 1994 SIP may proceed before the state board adopts the regulations pursuant to subdivision (a) of Section 44101 or the plan required by this subdivision. The emission credits assigned to these vehicles shall be adjusted as necessary to ensure that those credits are consistent with the credits allowed under the regulations adopted pursuant to Section 44101. The plan shall include a baseline study, for the geographical area or areas representative of those to be targeted by this program and by measure M-1 in the SIP, of the current population of vehicles by model year and market value and the current turnover rate of vehicles, and other factors that may be essential to assessing program effectiveness, cost-effectiveness, and market impacts of the program.

(b) At the end of each of the two calendar years after the adoption of the program plan, if the program receives adequate funding, the state board, in consultation with the department, shall adopt and publish a progress report evaluating each year of the program. These reports shall address the following topics for those vehicles scrapped to achieve both the M-1 SIP objectives and those vehicles scrapped or repaired to generate mobile-source emission reduction credits used for other purposes:

(1) The number of vehicles scrapped or repaired by model year.

(2) The measured emissions of the scrapped or repaired vehicles tested during the report period, using suitable inspection and maintenance test procedures.

(3) Costs of the vehicles in terms of amounts paid to sellers, the costs of repair, and the cost-effectiveness of scrapping and repair expressed in dollars per ton of emissions reduced.

(4) Administrative and testing costs for the program.

(5) Assessments of the replacement vehicles or replacement travel by model year or emission levels, as determined from interviews, questionnaires, diaries, analyses of vehicle registrations in the study region, or other methods as appropriate.

(6) Assessments of the net emission benefits of scrapping in the year reported, considering the scrapped vehicles, the replacement vehicles, the effectiveness of repair, and other effects of the program on the mix of vehicles and use of vehicles in the geographic area of the program, including in-migration of other vehicles into the area and any tendencies to increased market value of used vehicles and prolonged useful life of existing vehicles, if any.

(7) Assessments of whether the M-1 strategy of the 1994 SIP can reasonably be expected to yield the required emission reductions.

Added Stats 1995 ch 929 § 7 (SB 501). Amended Stats 2004 ch 644 § 23 (AB 2701); Stats 2012 ch 728 § 96 (SB 71), effective January 1, 2013.

#### § 44105. State oversight agency

The regulations shall specify that the program shall be operated as a privately operated program under the oversight of a state agency to be designated by the Governor. In consultation with the districts and interested parties, the state oversight agency shall be responsible for the implementation of the program, including the following:

(a) Solicitation and analysis of public comments on the overall program goals, objectives, and design.

(b) Development of the program structure.

(c) Overall quality control, including verifying emission reductions and certification of the emission reduction credits.

(d) Definition of terms such as “high emitter,” “collector interest vehicles,” and “nonrevivable junk certificates.”

Added Stats 1995 ch 929 § 7 (SB 501).

#### § 44106. Provisions for tampering and fraud

The program shall include provisions for monitoring and preventing all forms of tampering or other forms of cheating, and shall effectively address “avoidance vehicles” such as nonregistered vehicles and vehicles lacking a sufficient inspection and maintenance history. If fraud is detected, the program shall include provisions for suspending all new transactions with the entity suspected of fraud until problems are corrected and revaluing all credits used to meet the emissions reduction requirements. Contracts with authorized entities shall include remedies in cases of fraud.

Added Stats 1995 ch 929 § 7 (SB 501).

#### § 44107. Discouragement of tampering and fraud

The program shall discourage tampering and other forms of cheating, and effectively address “avoidance vehicles,” such as nonregistered vehicles and vehicles lacking a sufficient inspection and maintenance history.

Added Stats 1995 ch 929 § 7 (SB 501).

#### § 44109. Solicitation of vehicle owners

The program shall include appropriate means to solicit vehicle owners, including mass mailings, media advertising, news coverage, and direct mail to owners of candidate vehicles, and may include high-emitting vehicles based on smog check or remote sensing or high-emitter profile information.

Added Stats 1995 ch 929 § 7 (SB 501).

#### § 44115. Convenience of vehicle purchase transactions

The program shall ensure that vehicle purchase transactions are convenient to vehicle owners, including advance screening to reasonably assure that vehicles qualify for the program.

Added Stats 1995 ch 929 § 7 (SB 501).

#### § 44120. Vehicle disposal

Vehicle disposal under the program shall be consistent with appropriate state board guidance and provisions of the Vehicle Code dealing with vehicle disposal and parts reuse, and shall do both of the following:

(a) Allow for trading, sale, and resale of the vehicles between licensed auto dismantlers or other appropriate parties to maximize the salvage value of the vehicles through the recycling, sales, and use of parts of the vehicles, consistent with the Vehicle Code and appropriate state board guidelines.

(b) Set aside and resell to the public any vehicles with special collector interest. No emission reduction credit shall be generated for vehicles that are resold to the public. Vehicles acquired for their collector interest shall be properly repaired to meet minimum established vehicle emission standards before reregistration, unless the vehicle is sold with a nonrepairable vehicle certificate or a nonrevivable junk certificate.

Added Stats 1995 ch 929 § 7 (SB 501).

#### § 44121. Standards for certification and use of emission reduction credits

The state board shall develop standards for the certification and use of emission reduction credits to ensure that the credits are real, surplus, and quantifiable after accounting for program uncertainties.

Added Stats 1995 ch 929 § 7 (SB 501).

#### § 44122. Measurement of emission reductions

Emission reductions achieved from retired vehicles shall be quantified as follows:

(a) Vehicle emissions shall be based on either direct testing, statistical sampling, or emission modeling methods. Sampling of a statistically significant portion of the vehicles may be used to estimate emission benefits or to develop and validate correlations for use in estimating emission benefits.

(b) A reasonably reliable mechanism shall be applied to estimate vehicle miles traveled and the remaining useful life of each purchased vehicle. The odometer reading shall be matched on each purchased vehicle with the records of the Department of Motor Vehicles and smog check records to verify driving history, or statistical data shall be used to estimate vehicle use.

(c) An annual survey shall be performed of a statistically meaningful number of participants to determine replacement vehicle and post-participation behavior and also to determine the extent, if any, of in-migration of low-cost vehicles due to price increases in the scrapping market area resulting from the scrap program.

Added Stats 1995 ch 929 § 7 (SB 501).

## ARTICLE 11

### Enhanced Fleet Modernization Program

#### Section

44125. Voluntary retirement of high-polluting vehicles; Guidelines

44126. Enhanced Fleet Modernization Subaccount

**§ 44125. Voluntary retirement of high-polluting vehicles; Guidelines**

(a) No later than July 1, 2009, the state board, in consultation with the bureau, shall adopt a program to commence on January 1, 2010, that allows for the voluntary retirement of passenger vehicles and light-duty and medium-duty trucks that are high polluters. The program shall be administered by the bureau pursuant to guidelines adopted by the state board.

(b) No later than June 30, 2015, the state board, in consultation with the bureau, shall update the program established pursuant to subdivision (a). The program shall continue to be administered by the bureau pursuant to guidelines updated and adopted by the state board.

(c) The guidelines shall ensure all of the following:

(1) Vehicles retired pursuant to the program are permanently removed from operation and retired at a dismantler under contract with the bureau.

(2) Districts retain their authority to administer vehicle retirement programs otherwise authorized under law.

(3) The program is available for high polluting passenger vehicles and light-duty and medium-duty trucks that have been continuously registered in California for two years prior to acceptance into the program or otherwise proven to have been driven primarily in California for the last two years and have not been registered in another state or country in the last two years. The guidelines may require a vehicle to take, complete, or pass a smog check inspection.

(4) The program is focused where the greatest air quality impact can be identified.

(5)(A) Compensation for retired vehicles shall be at least one thousand five hundred dollars (\$1,500) for a low-income motor vehicle owner, as defined in Section 44062.1, and no more than one thousand dollars (\$1,000) for all other motor vehicle owners.

(B) Replacement may be an option for all motor vehicle owners and may be in addition to compensation for vehicles retired pursuant to subparagraph (A). For low-income motor vehicle owners, as defined in Section 44062.1, compensation shall be no less than two thousand five hundred dollars (\$2,500). Compensation for all other motor vehicle owners may not exceed compensation for low-income motor vehicle owners.

(C) Compensation for either retired or replacement vehicles for low-income motor vehicle owners may be increased as necessary to maximize the air quality benefits of the program while also ensuring participation by low-income motor vehicle owners, as defined in Section 44062.1. Increases in compensation amounts may be based on factors, including, but not limited to, the age of the retired or replaced vehicle, the emissions benefits of the retired or replaced vehicle, the emissions impact of any replacement vehicle, participation by low-income motor vehicle owners, as defined in Section 44062.1, and the location of the vehicle in an area of the state with the poorest air quality.

(6) Cost-effectiveness and impacts on disadvantaged and low-income populations are considered. Program eligibility may be limited on the basis of income to ensure the program adequately serves persons of low or moderate income.

(7) Provisions that coordinate the vehicle retirement and replacement components of the program with the vehicle retirement component of the bureau's Consumer Assistance Program, established pursuant to other provisions of this chapter, to ensure vehicle owners participate in the appropriate program to maximize emissions reductions.

(8) Streamlined administration to simplify participation while protecting the accountability of moneys spent.

(9) Specific steps to ensure the vehicle replacement component of the program is available in areas designated as federal extreme nonattainment.

(10) A requirement that vehicles eligible for retirement have sufficient remaining life. Demonstration of sufficient remaining life may include proof of current registration, passing a recent smog check inspection, or passing another test similar to a smog check inspection.

(d) When updating the guidelines to the program established pursuant to subdivision (a), the state board shall study and consider all the following elements:

(1) Methods of financial assistance other than vouchers.

(2) An option for automobile dealerships or other used car sellers to accept cars for retirement, provided the cars are dismantled consistent with the requirements of the program.

(3) An incentive structure with varied incentive amounts to maximize program participation and cost-effective emissions reductions.

(4) Increased emphasis on the replacement of high polluters with cleaner vehicles or the increased use of public transit that results in the increased utilization of the vehicle replacement component of the program.

(5) Increased emphasis on the reduction of greenhouse gas emissions through increased vehicle efficiency or transit use as a result of the program.

(6) Increased partnerships and outreach with community-based organizations.

Added Stats 2007 ch 750 § 4 (AB 118), effective January 1, 2008. Amended Stats 2008 ch 179 § 152 (SB 1498), effective January 1, 2009; Stats 2010 ch 231 § 3 (AB 787), effective January 1, 2011; Stats 2013 ch 401 § 5 (AB 8), effective September 28, 2013, ch 437 § 3 (SB 459), effective January 1, 2014.

**§ 44126. Enhanced Fleet Modernization Subaccount**

The Enhanced Fleet Modernization Subaccount is hereby created in the High Polluter Repair or Removal Account. All moneys deposited in the subaccount shall be available to the department and the BAR, upon appropriation by the Legislature, to establish and implement the program created pursuant to this article.

Added Stats 2007 ch 750 § 4 (AB 118), effective January 1, 2008. Amended Stats 2009 ch 200 § 4 (SB 734), effective January 1, 2010.

**CHAPTER 7**

**District Fees to Implement the California Clean Air Act**

Section 44225. (First of two; Repealed January 1, 2024) Conditions for increase in fee  
44225. (Second of two; Operative January 1, 2024) Conditions for increase in fee

Section

44229. (First of two; Repealed January 1, 2024) Distribution of revenues; Limitations on administrative costs  
 44229. (Second of two; Operative January 1, 2024) Distribution of revenues; Limitations on administrative costs

**§ 44225. (First of two; Repealed January 1, 2024) Conditions for increase in fee**

A district may increase the fee established under Section 44223 to up to six dollars (\$6). A district may increase the fee only if the following conditions are met:

(a) A resolution providing for both the fee increase and a corresponding program for expenditure of the increased fees for the reduction of air pollution from motor vehicles pursuant to, and for related planning, monitoring, enforcement, and technical studies necessary for the implementation of, the California Clean Air Act of 1988 is adopted and approved by the governing board of the district.

(b) In districts with nonelected officials on their governing boards, the resolution shall be adopted and approved by both a majority of the governing board and a majority of the board members who are elected officials.

(c) An increase in fees established pursuant to this section shall become effective on either April 1 or October 1, as provided in the resolution adopted by the board pursuant to subdivision (a).

(d) This section shall remain in effect only until January 1, 2024, and as of that date is repealed, unless a later enacted statute, that is enacted before January 1, 2024, deletes or extends that date.

Added Stats 1990 ch 1705 § 1 (AB 2766). Amended Stats 2004 ch 707 § 3 (AB 923), repealed January 1, 2015; Stats 2013 ch 401 § 6 (AB 8), effective September 28, 2013, repealed January 1, 2024.

**§ 44225. (Second of two; Operative January 1, 2024) Conditions for increase in fee**

A district may increase the fee established under Section 44223 to up to four dollars (\$4). A district may increase the fee only if the following conditions are met:

(a) A resolution providing for both the fee increase and a corresponding program for expenditure of the increased fees for the reduction of air pollution from motor vehicles pursuant to, and for related planning, monitoring, enforcement, and technical studies necessary for the implementation of, the California Clean Air Act of 1988 is adopted and approved by the governing board of the district.

(b) In districts with nonelected officials on their governing boards, the resolution shall be adopted and approved by both a majority of the governing board and a majority of the board members who are elected officials.

(c) An increase in fees established pursuant to this section shall become effective on either April 1 or October 1, as provided in the resolution adopted by the board pursuant to subdivision (a).

(d) This section shall become operative on January 1, 2024.

Added Stats 2004 ch 707 § 3.5 (AB 923), operative January 1, 2015. Amended Stats 2013 ch 401 § 7 (AB 8), effective September 28, 2013, operative January 1, 2024.

**§ 44229. (First of two; Repealed January 1, 2024) Distribution of revenues; Limitations on administrative costs**

(a) After deducting all administrative costs it incurs through collection of fees pursuant to Section 44227, the

Department of Motor Vehicles shall distribute the revenues to districts, which shall use the revenues resulting from the first four dollars (\$4) of each fee imposed to reduce air pollution from motor vehicles and to carry out related planning, monitoring, enforcement, and technical studies necessary for implementation of the California Clean Air Act of 1988. Fees collected by the Department of Motor Vehicles pursuant to this chapter shall be distributed to districts based upon the amount of fees collected from motor vehicles registered within each district.

(b) Notwithstanding Sections 44241 and 44243, a district shall use the revenues resulting from the next two dollars (\$2) of each fee imposed pursuant to Section 44227 to implement the following programs that the district determines remediate air pollution harms created by motor vehicles on which the surcharge is imposed:

(1) Projects eligible for grants under the Carl Moyer Memorial Air Quality Standards Attainment Program (Chapter 9 (commencing with Section 44275) of Part 5).

(2) The new purchase, retrofit, repower, or add-on equipment for previously unregulated agricultural sources of air pollution, as defined in Section 39011.5, for a minimum of three years from the date of adoption of an applicable rule or standard, or until the compliance date of that rule or standard, whichever is later, if the state board has determined that the rule or standard complies with Sections 40913, 40914, and 41503.1, after which period of time, a new purchase, retrofit, repower, or add-on of equipment shall not be funded pursuant to this chapter. The districts shall follow any guidelines developed under subdivision (a) of Section 44287 for awarding grants under this program.

(3) The purchase of new, or retrofit of emissions control equipment for existing, schoolbuses pursuant to the Lower-Emission School Bus Program adopted by the state board.

(4) An accelerated vehicle retirement or repair program that is adopted by the state board pursuant to authority granted hereafter by the Legislature by statute.

(5) The replacement of onboard natural gas fuel tanks on schoolbuses owned by a school district that are 14 years or older, not to exceed twenty thousand dollars (\$20,000) per bus, pursuant to the Lower-Emission School Bus Program adopted by the state board.

(6) The enhancement of deteriorating natural gas fueling dispensers of fueling infrastructure operated by a school district with a one-time funding amount not to exceed five hundred dollars (\$500) per dispenser, pursuant to the Lower-Emission School Bus Program adopted by the state board.

(c) The Department of Motor Vehicles may annually expend not more than 1 percent of the fees collected pursuant to Section 44227 on administrative costs.

(d) A project funded by the program shall not be used for credit under any state or federal emissions averaging, banking, or trading program. An emission reduction generated by the program shall not be used as marketable emission reduction credits or to offset any emission reduction obligation of any person or entity. Projects involving new engines that would otherwise generate marketable credits under state or federal averaging,

banking, and trading programs shall include transfer of credits to the engine end user and retirement of those credits toward reducing air emissions in order to qualify for funding under the program. A purchase of a low-emission vehicle or of equipment pursuant to a corporate or a controlling board's policy, but not otherwise required by law, shall generate surplus emissions reductions and may be funded by the program.

(e) This section shall remain in effect only until January 1, 2024, and as of that date is repealed, unless a later enacted statute, that is enacted before January 1, 2024, deletes or extends that date.

Added Stats 1990 ch 1705 § 1 (AB 2766). Amended Stats 2004 ch 707 § 4 (AB 923), repealed January 1, 2015; Stats 2011 ch 174 § 2 (AB 470), effective January 1, 2012, repealed January 1, 2015, ch 216 § 2.5 (AB 462), effective January 1, 2012, repealed January 1, 2015; Stats 2013 ch 401 § 8 (AB 8), effective September 28, 2013, repealed January 1, 2024.

**§ 44229. (Second of two; Operative January 1, 2024) Distribution of revenues; Limitations on administrative costs**

(a) After deducting all administrative costs it incurs through collection of fees pursuant to Section 44227, the Department of Motor Vehicles shall distribute the revenues to districts which shall use the fees to reduce air pollution from motor vehicles and to carry out related planning, monitoring, enforcement, and technical studies necessary for implementation of the California Clean Air Act of 1988. Fees collected by the Department of Motor Vehicles pursuant to this chapter shall be distributed to districts based upon the amount of fees collected from motor vehicles registered within each district.

(b) The Department of Motor Vehicles may annually expend not more than the following percentages of the fees collected pursuant to Section 44227 on administrative costs:

(1) During the first year after the operative date of this chapter, not more than 5 percent of the fees collected may be used for administrative costs.

(2) During the second year after the operative date of this chapter, not more than 3 percent of the fees collected may be used for administrative costs.

(3) During any year subsequent to the second year after the operative date of this chapter, not more than 1 percent of the fees collected may be used for administrative costs.

(c) This section shall become operative on January 1, 2024.

Added Stats 2004 ch 707 § 4.5 (AB 923), operative January 1, 2015. Amended Stats 2013 ch 401 § 9 (AB 8), effective September 28, 2013, operative January 1, 2024.

## CHAPTER 9

### Carl Moyer Memorial Air Quality Standards Attainment Program

#### ARTICLE 1

#### Definitions

Section

44275. (First of two; Repealed January 1, 2024) Definitions

44275. (Second of two; Operative January 1, 2024) Definitions

**§ 44275. (First of two; Repealed January 1, 2024) Definitions**

(a) As used in this chapter, the following terms have the following meanings:

(1) "Advisory board" means the Carl Moyer Program Advisory Board created by Section 44297.

(2) "Btu" means British thermal unit.

(3) "Commission" means the State Energy Resources Conservation and Development Commission.

(4) "Cost-effectiveness" means dollars provided to a project pursuant to subdivision (d) of Section 44283 for each ton of covered emission reduction attributed to a project or to the program as a whole. In calculating cost-effectiveness, one-time grants of funds made at the beginning of a project shall be annualized using a time value of public funds or discount rate determined for each project by the state board, taking into account the interest rate on bonds, interest earned by state funds, and other factors as determined appropriate by the state board. Cost-effectiveness shall be calculated by dividing annualized costs by average annual emissions reduction. The state board, in consultation with the districts and concerned members of the public, shall establish appropriate cost-effective limits for oxides of nitrogen, particulate matter, and reactive organic gases and a reasonable system for comparing the cost-effectiveness of proposed projects as described in subdivision (a) of Section 44283.

(5) "Covered emissions" include emissions of oxides of nitrogen, particulate matter, and reactive organic gases from any covered source.

(6) "Covered engine" includes any internal combustion engine or electric motor and drive powering a covered source.

(7) "Covered source" includes onroad vehicles, off-road nonrecreational equipment and vehicles, locomotives, diesel marine vessels, agricultural sources of air pollution, as defined in Section 39011.5, and, as determined by the state board, other high-emitting engine categories.

(8) "Covered vehicle" includes any vehicle or piece of equipment powered by a covered engine.

(9) "District" means a county air pollution control district or an air quality management district.

(10) "Fund" means the Air Pollution Control Fund established pursuant to Section 43015.

(11) "Mobile Source Air Pollution Reduction Review Committee" means the Mobile Source Air Pollution Reduction Review Committee created by Section 44244.

(12) "Incremental cost" means the cost of the project less a baseline cost that would otherwise be incurred by the applicant in the normal course of business. Incremental costs may include added lease or fuel costs pursuant to Section 44283 as well as incremental capital costs.

(13) "New very low emission vehicle" means a heavy-duty vehicle that qualifies as a very low emission vehicle when it is a new vehicle, where new vehicle has the same meaning as defined in Section 430 of the Vehicle Code, or that is modified with the approval and warranty of the original equipment manufacturer to qualify as a very low emission vehicle within 12 months of delivery to an owner for private or commercial use.

(14) "NO<sub>x</sub>" means oxides of nitrogen.

(15) “Program” means the Carl Moyer Memorial Air Quality Standards Attainment Program created by subdivision (a) of Section 44280.

(16) “Repower” means replacing an engine with a different engine. The term repower, as used in this chapter, generally refers to replacing an older, uncontrolled engine with a new, emissions-certified engine, although replacing an older emissions-certified engine with a newer engine certified to lower emissions standards may be eligible for funding under this program.

(17) “Retrofit” means making modifications to the engine and fuel system such that the retrofitted engine does not have the same specifications as the original engine.

(18) “Very low emission vehicle” means a heavy-duty vehicle with emissions significantly lower than otherwise applicable baseline emission standards or uncontrolled emission levels pursuant to Section 44282.

(b) This section shall remain in effect only until January 1, 2024, and as of that date is repealed, unless a later enacted statute, that is enacted before January 1, 2024, deletes or extends that date.

Added Stats 1999 ch 923 § 2 (AB 1571), effective October 10, 1999. Amended Stats 2004 ch 707 § 5 (AB 923), repealed January 1, 2015; Stats 2013 ch 401 § 15 (AB 8), effective September 28, 2013, repealed January 1, 2024.

**§ 44275. (Second of two; Operative January 1, 2024) Definitions**

(a) As used in this chapter, the following terms have the following meanings:

(1) “Advisory board” means the Carl Moyer Program Advisory Board created by Section 44297.

(2) “Btu” means British thermal unit.

(3) “Commission” means the State Energy Resources Conservation and Development Commission.

(4) “Cost-effectiveness” means dollars provided to a project pursuant to subdivision (d) of Section 44283 for each ton of NO<sub>x</sub> reduction attributed to a project or to the program as a whole. In calculating cost-effectiveness, one-time grants of funds made at the beginning of a project shall be annualized using a time value of public funds or discount rate determined for each project by the state board, taking into account the interest rate on bonds, interest earned by state funds, and other factors as determined appropriate by the state board. Cost-effectiveness shall be calculated by dividing annualized costs by average annual emissions reduction of NO<sub>x</sub> in this state.

(5) “Covered engine” includes any internal combustion engine or electric motor and drive powering a covered source.

(6) “Covered source” includes onroad vehicles of 14,000 pounds gross vehicle weight rating (GVWR) or greater, off-road nonrecreational equipment and vehicles, locomotives, diesel marine vessels, stationary agricultural engines, and, as determined by the state board, other high-emitting diesel engine categories.

(7) “Covered vehicle” includes any vehicle or piece of equipment powered by a covered engine.

(8) “District” means a county air pollution control district or an air quality management district.

(9) “Fund” means the Air Pollution Control Fund established pursuant to Section 43015.

(10) “Mobile Source Air Pollution Reduction Review Committee” means the Mobile Source Air Pollution Reduction Review Committee created by Section 44244.

(11) “Incremental cost” means the cost of the project less a baseline cost that would otherwise be incurred by the applicant in the normal course of business. Incremental costs may include added lease or fuel costs pursuant to Section 44283 as well as incremental capital costs.

(12) “New very low emission vehicle” means a vehicle that qualifies as a very low emission vehicle when it is a new vehicle, where new vehicle has the same meaning as defined in Section 430 of the Vehicle Code, or that is modified with the approval and warranty of the original equipment manufacturer to qualify as a very low emission vehicle within 12 months of delivery to an owner for private or commercial use.

(13) “NO<sub>x</sub>” means oxides of nitrogen.

(14) “Program” means the Carl Moyer Memorial Air Quality Standards Attainment Program created by subdivision (a) of Section 44280.

(15) “Repower” means replacing an engine with a different engine. The term repower, as used in this chapter, generally refers to replacing an older, uncontrolled engine with a new, emissions-certified engine, although replacing an older emissions-certified engine with a newer engine certified to lower emissions standards may be eligible for funding under this program.

(16) “Retrofit” means making modifications to the engine and fuel system such that the retrofitted engine does not have the same specifications as the original engine.

(17) “Very low emission vehicle” means a vehicle with emissions significantly lower than otherwise applicable baseline emission standards or uncontrolled emission levels pursuant to Section 44282.

(b) This section shall become operative on January 1, 2024.

Added Stats 2004 ch 707 § 5.5 (AB 923), operative January 1, 2015. Amended Stats 2013 ch 401 § 16 (AB 8), effective September 28, 2013, operative January 1, 2024.

**ARTICLE 2**

**Program Introduction**

Section 44280. (First of two; Repealed January 1, 2024) Creation of program  
44280. (Second of two; Operative January 1, 2024) Creation of program

**§ 44280. (First of two; Repealed January 1, 2024) Creation of program**

(a) There is hereby created the Carl Moyer Memorial Air Quality Standards Attainment Program. The program shall be administered by the state board in accordance with this chapter. The administration of the program may be delegated to the districts.

(b) The program shall provide grants to offset the incremental cost of projects that reduce covered emissions from covered sources in California. Eligibility for grant awards shall be determined by the state board, in consultation with the districts, in accordance with this chapter.

(c) The program shall also provide funding for a fueling infrastructure demonstration program and for

technology development efforts that are expected to result in commercially available technologies in the near-term that would improve the ability of the program to achieve its goals. The infrastructure demonstration and technology development portions of the program shall be managed by the commission, in consultation with the state board.

(d) This section shall remain in effect only until January 1, 2024, and as of that date is repealed, unless a later enacted statute, that is enacted before January 1, 2024, deletes or extends that date.

Added Stats 1999 ch 923 § 2 (AB 1571), effective October 10, 1999. Amended Stats 2004 ch 707 § 6 (AB 923), repealed January 1, 2015; Stats 2013 ch 401 § 17 (AB 8), effective September 28, 2013, repealed January 1, 2024.

**§ 44280. (Second of two; Operative January 1, 2024) Creation of program**

(a) There is hereby created the Carl Moyer Memorial Air Quality Standards Attainment Program. The program shall be administered by the state board in accordance with this chapter. The administration of the program may be delegated to the districts.

(b) The program shall provide grants to offset the incremental cost of projects that reduce emissions of NO<sub>x</sub> from covered sources in California. Eligibility for grant awards shall be determined by the state board, in consultation with the districts, in accordance with this chapter.

(c) The program shall also provide funding for a fueling infrastructure demonstration program and for technology development efforts that are expected to result in commercially available technologies in the near-term that would improve the ability of the program to achieve its goals. The infrastructure demonstration and technology development portions of the program shall be managed by the commission, in consultation with the state board.

(d) This section shall become operative on January 1, 2024.

Added Stats 2004 ch 707 § 6.5 (AB 923), operative January 1, 2015. Amended Stats 2013 ch 401 § 18 (AB 8), effective September 28, 2013, operative January 1, 2024.

## ARTICLE 3

### Eligible Projects and Applicants

Section

44281. (First of two; Repealed January 1, 2024) Eligible projects and applicants

44281. (Second of two; Operative January 1, 2024) Eligible projects and applicants

**§ 44281. (First of two; Repealed January 1, 2024) Eligible projects and applicants**

(a) Eligible projects include, but are not limited to, any of the following:

(1) Purchase of new very low or zero-emission covered vehicles or covered heavy-duty engines.

(2) Emission-reducing retrofit of covered engines, or replacement of old engines powering covered sources with newer engines certified to more stringent emissions standards than the engine being replaced, or with electric motors or drives.

(3) Purchase and use of emission-reducing add-on equipment that has been verified by the state board for covered vehicles.

(4) Development and demonstration of practical, low-emission retrofit technologies, repower options, and advanced technologies for covered engines and vehicles with very low emissions of NO<sub>x</sub>.

(5) Light- and medium-duty vehicle projects in compliance with guidelines adopted by the state board pursuant to Title 13 of the California Code of Regulations.

(b) No project shall be funded under this chapter after the compliance date required by any local, state, or federal statute, rule, regulation, memoranda of agreement or understanding, or other legally binding document, except that an otherwise qualified project may be funded even if the state implementation plan assumes that the change in equipment, vehicles, or operations will occur, if the change is not required by the compliance date of a statute, regulation, or other legally binding document in effect as of the date the grant is awarded. No project funded by the program shall be used for credit under any state or federal emissions averaging, banking, or trading program. No emission reduction generated by the program shall be used as marketable emission reduction credits or to offset any emission reduction obligation of any person or entity. Projects involving new engines that would otherwise generate marketable credits under state or federal averaging, banking, and trading programs shall include transfer of credits to the engine end user and retirement of those credits toward reducing air emissions in order to qualify for funding under the program. A purchase of a low-emission vehicle or of equipment pursuant to a corporate or a controlling board's policy, but not otherwise required by law, shall generate surplus emissions reductions and may be funded by the program.

(c) The program may also provide funding toward installation of fueling or electrification infrastructure as provided in Section 44284.

(d) Eligible applicants may be any individual, company, or public agency that owns one or more covered vehicles that operate primarily within California or otherwise contribute substantially to the NO<sub>x</sub>, particulate matter (PM), or reactive organic gas (ROG) emissions inventory in California.

(e) It is the intent of the Legislature that all emission reductions generated by this chapter shall contribute to public health by reducing, for the life of the vehicle being funded, the total amount of emissions in California.

(f) This section shall remain in effect only until January 1, 2024, and as of that date is repealed, unless a later enacted statute, that is enacted before January 1, 2024, deletes or extends that date.

Added Stats 1999 ch 923 § 2 (AB 1571), effective October 10, 1999. Amended Stats 2004 ch 707 § 7 (AB 923), repealed January 1, 2015; Stats 2013 ch 401 § 19 (AB 8), effective September 28, 2013, repealed January 1, 2024.

**§ 44281. (Second of two; Operative January 1, 2024) Eligible projects and applicants**

(a) Eligible projects are any of the following:

(1) Purchase of new very low or zero-emission covered vehicles or covered engines.

(2) Emission-reducing retrofit of covered engines, or replacement of old engines powering covered sources with newer engines certified to more stringent emissions standards than the engine being replaced, or with electric motors or drives.

(3) Purchase and use of emission-reducing add-on equipment for covered vehicles.

(4) Development and demonstration of practical, low-emission retrofit technologies, repower options, and advanced technologies for covered engines and vehicles with very low emissions of NO<sub>x</sub>.

(b) No new purchase, retrofit, repower, or add-on equipment shall be funded under this chapter if it is required by any local, state, or federal statute, rule, regulation, memoranda of agreement or understanding, or other legally binding document, except that an otherwise qualified project may be funded even if the state implementation plan assumes that the change in equipment, vehicles, or operations will occur, if the change is not required by a statute, regulation, or other legally binding document in effect as of the date the grant is awarded. No project funded by the program shall be used for credit under any state or federal emissions averaging, banking, or trading program. No emission reduction generated by the program shall be used as marketable emission reduction credits or to offset any emission reduction obligation of any entity. Projects involving new engines that would otherwise generate marketable credits under state or federal averaging, banking, and trading programs shall include transfer of credits to the engine end user and retirement of those credits toward reducing air emissions in order to qualify for funding under the program. A purchase of a low-emission vehicle or of equipment pursuant to a corporate or a controlling board's policy, but not otherwise required by law, shall generate surplus emissions reductions and may be funded by the program.

(c) The program may also provide funding toward installation of fueling or electrification infrastructure as provided in Section 44284.

(d) Eligible applicants may be any individual, company, or public agency that owns one or more covered vehicles that operate primarily within California or otherwise contribute substantially to the NO<sub>x</sub> emissions inventory in California.

(e) It is the intent of the Legislature that all emission reductions generated by this chapter shall contribute to public health by reducing, for the life of the vehicle being funded, the total amount of emissions in California.

(f) This section shall become operative on January 1, 2024.

Added Stats 2004 ch 707 § 7.5 (AB 923), operative January 1, 2015. Amended Stats 2013 ch 401 § 20 (AB 8), effective September 28, 2013, operative January 1, 2024.

## ARTICLE 4

### General Eligibility Criteria

Section

44282. (First of two; Repealed January 1, 2024) Criteria for projects  
44282. (Second of two; Operative January 1, 2024) Criteria for projects

### § 44282. (First of two; Repealed January 1, 2024) Criteria for projects

The following criteria apply to all projects to be funded through the program except for projects funded through the infrastructure demonstration program:

(a) The state board may establish project criteria, including minimum project life for source categories, in the guidelines described in Section 44287. For previously unregulated source categories, project criteria shall consider the timing of newly established regulatory requirements.

(b) To be eligible, projects shall meet the cost-effectiveness per ton of covered emissions reduced requirements of Section 44283.

(c) To be eligible, retrofits, repowers, and installation of add-on equipment for covered vehicles shall be performed, or new covered vehicles delivered to the end user, or covered vehicles scrapped on or after the date the program is implemented.

(d) Retrofit technologies, new engines, and new vehicles shall be certified for sale or under experimental permit for operation in California.

(e) Repower projects that replace older, uncontrolled engines with new, emissions-certified engines or that replace emissions-certified engines with new engines certified to a more stringent NO<sub>x</sub> emissions standard are approvable subject to the other applicable selection criteria. The state board shall determine appropriate baseline emission levels for the uncontrolled engines being replaced.

(f) For heavy-duty-vehicle projects, retrofit and add-on equipment projects shall document a NO<sub>x</sub> or PM emission reduction of at least 25 percent and no increase in other covered emissions compared to the applicable baseline emissions accepted by the state board for that engine year and application. The state board shall determine appropriate baseline emission levels. Acceptable documentation shall be defined by the state board. After study of available emission reduction technologies and after public notice and comment, the state board may revise the minimum percentage emission reduction criterion for retrofits and add-on equipment provided for in this section to improve the ability of the program to achieve its goals.

(g)(1) For heavy-duty-vehicle projects involving the purchase of new very low or zero-emission vehicles, engines shall be certified to an optional low NO<sub>x</sub> emissions standard established by the state board, except as provided for in paragraph (2).

(2) For heavy-duty-vehicle projects involving the purchase of new very low or zero-emission covered vehicles for which no optional low NO<sub>x</sub> emission standards are available, documentation shall be provided showing that the low or zero-emission engine emits not more than 70 percent of the NO<sub>x</sub> or NO<sub>x</sub> plus hydrocarbon emissions of a new engine certified to the applicable baseline NO<sub>x</sub> or NO<sub>x</sub> plus hydrocarbon emission standard for that engine and meets applicable particulate standards. The state board shall specify the documentation required. If no baseline emission standard exists for new vehicles in a particular category, the state board shall determine an appropriate baseline emission level for comparison.

(h) For projects other than heavy-duty-vehicle projects, the state board shall determine appropriate criteria under the provisions of Section 44287.



(i) This section shall remain in effect only until January 1, 2024, and as of that date is repealed, unless a later enacted statute, that is enacted before January 1, 2024, deletes or extends that date.

Added Stats 1999 ch 923 § 2 (AB 1571), effective October 10, 1999. Amended Stats 2004 ch 707 § 8 (AB 923), repealed January 1, 2015; Stats 2013 ch 401 § 21 (AB 8), effective September 28, 2013, repealed January 1, 2024.

**§ 44282. (Second of two; Operative January 1, 2024) Criteria for projects**

The following criteria apply to all projects to be funded through the program except for projects funded through the infrastructure demonstration program:

(a) Except for projects involving marine vessels, 75 percent or more of vehicle miles traveled or hours of operation shall be projected to be in California for at least five years following the grant award. Projects involving marine vessels and engines shall be limited to those that spend enough time operating in California air basins over the lifetime of the project to meet the cost-effectiveness criteria based on NO<sub>x</sub> reductions in California, as provided in Section 44283.

(b) To be eligible, projects shall meet cost-effectiveness per ton of NO<sub>x</sub> reduced requirements of Section 44283.

(c) To be eligible, retrofits, repowers, and installation of add-on equipment for covered vehicles shall be performed, or new covered vehicles delivered to the end user, on or after the date the program is implemented.

(d) Retrofit technologies, new engines, and new vehicles shall be certified for sale or under experimental permit for operation in California.

(e) Repower projects that replace older, uncontrolled engines with new, emissions-certified engines or that replace emissions-certified engines with new engines certified to a more stringent NO<sub>x</sub> emissions standard are approvable subject to the other applicable selection criteria. The state board shall determine appropriate baseline emission levels for the uncontrolled engines being replaced.

(f) Retrofit and add-on equipment projects shall document a NO<sub>x</sub> emission reduction of at least 25 percent and no increase in particulate emissions compared to the applicable baseline emissions accepted by the state board for that engine year and application. The state board shall determine appropriate baseline emission levels. Acceptable documentation shall be defined by the state board. After study of available emission reduction technologies and after public notice and comment, the state board may revise the minimum percentage NO<sub>x</sub> reduction criterion for retrofits and add-on equipment provided for in this section to improve the ability of the program to achieve its goals.

(g)(1) For projects involving the purchase of new very low or zero-emission vehicles, engines shall be certified to an optional low NO<sub>x</sub> emissions standard established by the state board, except as provided for in paragraph (2).

(2) For projects involving the purchase of new very low or zero-emission covered vehicles for which no optional low NO<sub>x</sub> emission standards are available, documentation shall be provided showing that the low or zero-emission engine emits not more than 70 percent of

the NO<sub>x</sub> or NO<sub>x</sub> plus hydrocarbon emissions of a new engine certified to the applicable baseline NO<sub>x</sub> or NO<sub>x</sub> plus hydrocarbon emission standard for that engine and meets applicable particulate standards. The state board shall specify the documentation required. If no baseline emission standard exists for new vehicles in a particular category, the state board shall determine an appropriate baseline emission level for comparison.

(h) This section shall become operative on January 1, 2024.

Added Stats 2004 ch 707 § 8.5 (AB 923), operative January 1, 2015. Amended Stats 2013 ch 401 § 22 (AB 8), effective September 28, 2013, operative January 1, 2024.

## ARTICLE 5

### Cost-Effectiveness Criteria

Section

44283. (First of two; Repealed January 1, 2024) Cost-effectiveness criteria

44283. (Second of two; Operative January 1, 2024) Cost-effectiveness criteria

**§ 44283. (First of two; Repealed January 1, 2024) Cost-effectiveness criteria**

(a) Grants shall not be made for projects with a cost-effectiveness, calculated in accordance with this section, of more than thirteen thousand six hundred dollars (\$13,600) per ton of NO<sub>x</sub> reduced in California or a higher value that reflects state consumer price index adjustments on or after January 1, 2006, as determined by the state board. For projects obtaining reactive organic gas and particulate matter reductions, the state board shall determine appropriate adjustment factors to calculate a weighted cost-effectiveness.

(b) Only covered emission reductions occurring in this state shall be included in the cost-effectiveness determination. The extent to which emissions generated at sea contribute to air quality in California nonattainment areas shall be incorporated into these methodologies based on a reasonable assessment of currently available information and modeling assumptions.

(c) The state board shall develop protocols for calculating the surplus covered emission reductions in California from representative project types over the life of the project.

(d) The cost of the covered emission reduction is the amount of the grant from the program, including matching funds provided pursuant to subdivision (e) of Section 44287, plus any other state funds, or funds under the district's budget authority or fiduciary control, provided toward the project, not including funds described in paragraphs (1) and (2) of subdivision (a) of Section 44287.2. The state board shall establish reasonable methodologies for evaluating project cost-effectiveness, consistent with the definition contained in paragraph (4) of subdivision (a) of Section 44275, and with accepted methods, taking into account a fair and reasonable discount rate or time value of public funds.

(e) A grant shall not be made that, net of taxes, provides the applicant with funds in excess of the incremental cost of the project. Incremental lease costs may be capitalized according to guidelines adopted by the

state board so that these incremental costs may be offset by a one-time grant award.

(f) Funds under a district's budget authority or fiduciary control may be used to pay for the incremental cost of liquid or gaseous fuel, other than standard gasoline or diesel, which is integral to a covered emission reducing technology that is part of a project receiving grant funding under the program. The fuel shall be approved for sale by the state board. The incremental fuel cost over the expected lifetime of the vehicle may be offset by the district if the project as a whole, including the incremental fuel cost, meets all of the requirements of this chapter, including the maximum allowed cost-effectiveness. The state board shall develop an appropriate methodology for converting incremental fuel costs over the vehicle lifetime into an initial cost for the purposes of determining project cost-effectiveness. Incremental fuel costs shall not be included in project costs for fuels dispensed from any facility that was funded, in whole or in part, from the fund.

(g) For purposes of determining any grant amount pursuant to this chapter, the incremental cost of any new purchase, retrofit, repower, or add-on equipment shall be reduced by the value of any current financial incentive that directly reduces the project price, including any tax credits or deductions, grants, or other public financial assistance, not including funds described in paragraphs (1) and (2) of subdivision (a) of Section 44287.2. Project proponents applying for funding shall be required to state in their application any other public financial assistance to the project.

(h) For projects that would repower off-road equipment by replacing uncontrolled diesel engines with new, certified diesel engines, the state board may establish maximum grant award amounts per repower. A repower project shall also be subject to the incremental cost maximum pursuant to subdivision (e).

(i) After study of available emission reduction technologies and costs and after public notice and comment, the state board may reduce the values of the maximum grant award criteria stated in this section to improve the ability of the program to achieve its goals. Every year the state board shall adjust the maximum cost-effectiveness amount established in subdivision (a) and any per-project maximum set by the state board pursuant to subdivision (h) to account for inflation.

(j) This section shall remain in effect only until January 1, 2024, and as of that date is repealed, unless a later enacted statute, that is enacted before January 1, 2024, deletes or extends that date.

Added Stats 1999 ch 923 § 2 (AB 1571), effective October 10, 1999. Amended Stats 2004 ch 707 § 9 (AB 923), repealed January 1, 2015; Stats 2006 ch 627 § 1 (SB 225), effective January 1, 2007, repealed January 1, 2015; Stats 2010 ch 571 § 1 (AB 1507), effective January 1, 2011, repealed January 1, 2015; Stats 2013 ch 401 § 23 (AB 8), effective September 28, 2013, repealed January 1, 2024.

**§ 44283. (Second of two; Operative January 1, 2024) Cost-effectiveness criteria**

(a) Grants shall not be made for projects with a cost-effectiveness, calculated in accordance with this section, of more than twelve thousand dollars (\$12,000) per ton of NO<sub>x</sub> reduced in California or a higher value that reflects state consumer price index adjustments on

or after January 1, 2024, as determined by the state board.

(b) Only NO<sub>x</sub> reductions occurring in this state shall be included in the cost-effectiveness determination. The extent to which emissions generated at sea contribute to air quality in California nonattainment areas shall be incorporated into these methodologies based on a reasonable assessment of currently available information and modeling assumptions.

(c) The state board shall develop protocols for calculating the surplus NO<sub>x</sub> reductions in California from representative project types over the life of the project.

(d) The cost of the NO<sub>x</sub> reduction is the amount of the grant from the program, including matching funds provided pursuant to subdivision (e) of Section 44287, plus any other state funds, or funds under the district's budget authority or fiduciary control, provided toward the project, not including funds described in paragraphs (1) and (2) of subdivision (a) of Section 44287.2. The state board shall establish reasonable methodologies for evaluating project cost-effectiveness, consistent with the definition contained in paragraph (4) of subdivision (a) of Section 44275, and with accepted methods, taking into account a fair and reasonable discount rate or time value of public funds.

(e) A grant shall not be made that, net of taxes, provides the applicant with funds in excess of the incremental cost of the project. Incremental lease costs may be capitalized according to guidelines adopted by the state board so that these incremental costs may be offset by a one-time grant award.

(f) Funds under a district's budget authority or fiduciary control may be used to pay for the incremental cost of liquid or gaseous fuel, other than standard gasoline or diesel, which is integral to a NO<sub>x</sub> reducing technology that is part of a project receiving grant funding under the program. The fuel shall be approved for sale by the state board. The incremental fuel cost over the expected lifetime of the vehicle may be offset by the district if the project as a whole, including the incremental fuel cost, meets all of the requirements of this chapter, including the maximum allowed cost-effectiveness. The state board shall develop an appropriate methodology for converting incremental fuel costs over the vehicle lifetime into an initial cost for the purposes of determining project cost-effectiveness. Incremental fuel costs shall not be included in project costs for fuels dispensed from any facility that was funded, in whole or in part, from the fund.

(g) For purposes of determining any grant amount pursuant to this chapter, the incremental cost of any new purchase, retrofit, repower, or add-on equipment shall be reduced by the value of any current financial incentive that directly reduces the project price, including any tax credits or deductions, grants, or other public financial assistance, not including funds described in paragraphs (1) and (2) of subdivision (a) of Section 44287.2. Project proponents applying for funding shall be required to state in their application any other public financial assistance to the project.

(h) For projects that would repower off-road equipment by replacing uncontrolled diesel engines with new, certified diesel engines, the state board may establish maximum grant award amounts per repower. A repower

project shall also be subject to the incremental cost maximum pursuant to subdivision (e).

(i) After study of available emission reduction technologies and costs and after public notice and comment, the state board may reduce the values of the maximum grant award criteria stated in this section to improve the ability of the program to achieve its goals. Every year the state board shall adjust the maximum cost-effectiveness amount established in subdivision (a) and any per-project maximum set by the state board pursuant to subdivision (h) to account for inflation.

(j) This section shall become operative on January 1, 2024.

Added Stats 2004 ch 707 § 9.5 (AB 923), operative January 1, 2015. Amended Stats 2006 ch 627 § 2 (SB 225), effective January 1, 2007, operative January 1, 2015; Stats 2010 ch 571 § 2 (AB 1507), effective January 1, 2011, operative January 1, 2015; Stats 2013 ch 401 § 24 (AB 8), effective September 28, 2013, operative January 1, 2024.

## ARTICLE 8

### Program Administration: General

#### Section

44287. (First of two; Repealed January 1, 2024) Grant criteria and guidelines; Reservation of funds

44287. (Second of two; Operative January 1, 2024) Grant criteria and guidelines; Reservation of funds

#### § 44287. (First of two; Repealed January 1, 2024) Grant criteria and guidelines; Reservation of funds

(a) The state board shall establish or update grant criteria and guidelines consistent with this chapter for covered vehicle projects as soon as practicable, but not later than January 1, 2006. The adoption of guidelines is exempt from the rulemaking provisions of the Administrative Procedure Act, Chapter 3.5 (commencing with Section 11340) of Part 1 of Division 3 of Title 2 of the Government Code. The state board shall solicit input and comment from the districts during the development of the criteria and guidelines and shall make every effort to develop criteria and guidelines that are compatible with existing district programs that are also consistent with this chapter. Guidelines shall include protocols to calculate project cost-effectiveness. The grant criteria and guidelines shall include safeguards to ensure that the project generates surplus emissions reductions. Guidelines shall enable and encourage districts to co-fund projects that provide emissions reductions in more than one district. The state board shall make draft criteria and guidelines available to the public 45 days before final adoption, and shall hold at least one public meeting to consider public comments before final adoption. The state board may develop separate guidelines and criteria for the different types of eligible projects described in subdivision (a) of Section 44281.

(b) The state board, in consultation with the participating districts, may propose revisions to the criteria and guidelines established pursuant to subdivision (a) as necessary to improve the ability of the program to achieve its goals. A proposed revision shall be made available to the public 45 days before final adoption of the revision and the state board shall hold at least one public meeting to consider public comments before final adoption of the revision.

(c) The state board shall reserve funds for, and disburse funds to, districts from the fund for administration pursuant to this section and Section 44299.1.

(d) The state board shall develop guidelines for a district to follow in applying for the reservation of funds, in accordance with this chapter. It is the intent of the Legislature that district administration of any reserved funds be in accordance with the project selection criteria specified in Sections 44281, 44282, and 44283 and all other provisions of this chapter. The guidelines shall be established and published by the state board as soon as practicable, but not later than January 1, 2006.

(e) Funds shall be reserved by the state board for administration by a district that adopts an eligible program pursuant to this chapter and offers matching funds at a ratio of one dollar (\$1) of matching funds committed by the district or the Mobile Source Air Pollution Reduction Review Committee for every two dollars (\$2) committed from the fund. Funds available to the Mobile Source Air Pollution Reduction Review Committee may be counted as matching funds for projects in the South Coast Air Basin only if the committee approves the use of these funds for matching purposes. Matching funds may be any funds under the district's budget authority that are committed to be expended in accordance with the program. Funds committed by a port authority or a local government, in cooperation with a district, to be expended in accordance with the program may also be counted as district matching funds. Matching funds provided by a port authority or a local government may not exceed 30 percent of the total required matching funds in any district that applies for more than three hundred thousand dollars (\$300,000) of the state board funds. Only a district, or a port authority or a local government teamed with a district, may provide matching funds.

(f) The state board may adjust the ratio of matching funds described in subdivision (e), if it determines that an adjustment is necessary in order to maximize the use of, or the air quality benefits provided by, the program, based on a consideration of the financial resources of the district.

(g) Notwithstanding subdivision (e), a district need not provide matching funds for state board funds allocated to the district for program outreach activities pursuant to paragraph (4) of subdivision (a) of Section 44299.1.

(h) A district may include within its matching funds a reasonable estimate of direct or in-kind costs for assistance in providing program outreach and application evaluation. In-kind and direct matching funds shall not exceed 15 percent of the total matching funds offered by a district. A district may also include within its matching funds any money spent on or after February 25, 1999, that would have qualified as matching funds but were not previously claimed as matching funds.

(i) A district desiring a reservation of funds shall apply to the state board following the application guidelines established pursuant to this section. The state board shall approve or disapprove a district application not later than 60 days after receipt. Upon approval of any district application, the state board shall simultaneously approve a reservation of funding for that district to administer. Reserved funds shall be disbursed to the

district so that funding of a district-approved project is not impeded.

(j) Notwithstanding any other provision of this chapter, districts and the Mobile Source Air Pollution Reduction Review Committee shall not use funds collected pursuant to Section 41081 or Chapter 7 (commencing with Section 44220), or pursuant to Section 9250.11 of the Vehicle Code, as matching funds to fund a project with stationary or portable engines, locomotives, or marine vessels.

(k) Any funds reserved for a district pursuant to this section are available to the district for a period of not more than two years from the time of reservation. Funds not expended by June 30 of the second calendar year following the date of the reservation shall revert back to the state board as of that June 30, and shall be deposited in the fund for use by the program. The funds may then be redirected based on applications to the fund. Regardless of any reversion of funds back to the state board, the district may continue to request other reservations of funds for local administration. Each reservation of funds shall be accounted for separately, and unused funds from each application shall revert back to the state board as specified in this subdivision.

(l) The state board shall specify a date each year when district applications are due. If the eligible applications received in any year oversubscribe the available funds, the state board shall reserve funds on an allocation basis, pursuant to Section 44299.2. The state board may accept a district application after the due date for a period of months specified by the state board. Funds may be reserved in response to those applications, in accordance with this chapter, out of funds remaining after the original reservation of funds for the year.

(m) Guidelines for a district application shall require information from an applicant district to the extent necessary to meet the requirements of this chapter, but shall otherwise minimize the information required of a district.

(n) A district application shall be reviewed by the state board immediately upon receipt. If the state board determines that an application is incomplete, the applicant shall be notified within 10 working days with an explanation of what is missing from the application. A completed application fulfilling the criteria shall be approved as soon as practicable, but not later than 60 working days after receipt.

(o) The commission, in consultation with the districts, shall establish project approval criteria and guidelines for infrastructure projects consistent with Section 44284 as soon as practicable, but not later than February 15, 2000. The commission shall make draft criteria and guidelines available to the public 45 days before final adoption, and shall hold at least one public meeting to consider public comments before final adoption.

(p) The commission, in consultation with the participating districts, may propose revisions to the criteria and guidelines established pursuant to subdivision (o) as necessary to improve the ability of the program to achieve its goals. A revision may be proposed at any time, or may be proposed in response to a finding made in the annual report on the program published by the state board pursuant to Section 44295. A proposed revision shall be made available to the public 45 days before final

adoption of the revision and the commission shall hold at least one public meeting to consider public comments before final adoption of the revision.

(q) Unclaimed funds will be allocated by the state board in accordance with Section 44299.2.

(r) This section shall remain in effect only until January 1, 2024, and as of that date is repealed, unless a later enacted statute, that is enacted before January 1, 2024, deletes or extends that date.

Added Stats 1999 ch 923 § 2 (AB 1571), effective October 10, 1999. Amended Stats 2000 ch 135 § 99 (AB 2539), ch 729 § 15 (SB 1300); Stats 2004 ch 707 § 10 (AB 923), repealed January 1, 2015; Stats 2013 ch 401 § 25 (AB 8), effective September 28, 2013, repealed January 1, 2024.

**§ 44287. (Second of two; Operative January 1, 2024) Grant criteria and guidelines; Reservation of funds**

(a) The state board shall establish grant criteria and guidelines consistent with this chapter for covered vehicle projects as soon as practicable, but not later than January 1, 2000. The adoption of guidelines is exempt from the rulemaking provisions of the Administrative Procedure Act, Chapter 3.5 (commencing with Section 11340) of Part 1 of Division 3 of Title 2 of the Government Code. The state board shall solicit input and comment from the districts during the development of the criteria and guidelines and shall make every effort to develop criteria and guidelines that are compatible with existing district programs that are also consistent with this chapter. Guidelines shall include protocols to calculate project cost-effectiveness. The grant criteria and guidelines shall include safeguards to ensure that the project generates surplus emissions reductions. Guidelines shall enable and encourage districts to cofund projects that provide emissions reductions in more than one district. The state board shall make draft criteria and guidelines available to the public 45 days before final adoption, and shall hold at least one public meeting to consider public comments before final adoption.

(b) The state board, in consultation with the participating districts, may propose revisions to the criteria and guidelines established pursuant to subdivision (a) as necessary to improve the ability of the program to achieve its goals. A proposed revision shall be made available to the public 45 days before final adoption of the revision and the state board shall hold at least one public meeting to consider public comments before final adoption of the revision.

(c) The state board shall reserve funds for, and disburse funds to, districts from the fund for administration pursuant to this section and Section 44299.1.

(d) The state board shall develop guidelines for a district to follow in applying for the reservation of funds, in accordance with this chapter. It is the intent of the Legislature that district administration of any reserved funds be in accordance with the project selection criteria specified in Sections 44281, 44282, and 44283 and all other provisions of this chapter. The guidelines shall be established and published by the state board as soon as practicable, but not later than January 1, 2000.

(e) Funds shall be reserved by the state board for administration by a district that adopts an eligible program pursuant to this chapter and offers matching funds at a ratio of one dollar (\$1) of matching funds

committed by the district or the Mobile Source Air Pollution Reduction Review Committee for every two dollars (\$2) committed from the fund. Funds available to the Mobile Source Air Pollution Reduction Review Committee may be counted as matching funds for projects in the South Coast Air Basin only if the committee approves the use of these funds for matching purposes. Matching funds may be any funds under the district's budget authority that are committed to be expended in accordance with the program. Funds committed by a port authority or a local government, in cooperation with a district, to be expended in accordance with the program may also be counted as district matching funds. Matching funds provided by a port authority or a local government may not exceed 30 percent of the total required matching funds in any district that applies for more than three hundred thousand dollars (\$300,000) of the state board funds. Only a district, or a port authority or a local government teamed with a district, may provide matching funds.

(f) The state board may adjust the ratio of matching funds described in subdivision (e), if it determines that an adjustment is necessary in order to maximize the use of, or the air quality benefits provided by, the program, based on a consideration of the financial resources of the district.

(g) Notwithstanding subdivision (e), a district need not provide matching funds for state board funds allocated to the district for program outreach activities pursuant to paragraph (4) of subdivision (a) of Section 44299.1.

(h) A district may include within its matching funds a reasonable estimate of direct or in-kind costs for assistance in providing program outreach and application evaluation. In-kind and direct matching funds shall not exceed 15 percent of the total matching funds offered by a district. A district may also include within its matching funds any money spent on or after February 25, 1999, that would have qualified as matching funds but were not previously claimed as matching funds.

(i) A district desiring a reservation of funds shall apply to the state board following the application guidelines established pursuant to this section. The state board shall approve or disapprove a district application not later than 60 days after receipt. Upon approval of any district application, the state board shall simultaneously approve a reservation of funding for that district to administer. Reserved funds shall be disbursed to the district so that funding of a district-approved project is not impeded.

(j) Notwithstanding any other provision of this chapter, districts and the Mobile Source Air Pollution Reduction Review Committee shall not use funds collected pursuant to Section 41081 or Chapter 7 (commencing with Section 44220), or pursuant to Section 9250.11 of the Vehicle Code, as matching funds to fund a project with stationary or portable engines, locomotives, or marine vessels.

(k) Any funds reserved for a district pursuant to this section are available to the district for a period of not more than two years from the time of reservation. Funds not expended by June 30 of the second calendar year following the date of the reservation shall revert back to the state board as of that June 30, and shall be deposited

in the fund for use by the program. The funds may then be redirected based on applications to the fund. Regardless of any reversion of funds back to the state board, the district may continue to request other reservations of funds for local administration. Each reservation of funds shall be accounted for separately, and unused funds from each application shall revert back to the state board as specified in this subdivision.

(l) The state board shall specify a date each year when district applications are due. If the eligible applications received in any year oversubscribe the available funds, the state board shall reserve funds on an allocation basis, pursuant to subdivision (b) of Section 44299.1. The state board may accept a district application after the due date for a period of months specified by the state board. Funds may be reserved in response to those applications, in accordance with this chapter, out of funds remaining after the original reservation of funds for the year.

(m) Guidelines for a district application shall require information from an applicant district to the extent necessary to meet the requirements of this chapter, but shall otherwise minimize the information required of a district.

(n) A district application shall be reviewed by the state board immediately upon receipt. If the state board determines that an application is incomplete, the applicant shall be notified within 10 working days with an explanation of what is missing from the application. A completed application fulfilling the criteria shall be approved as soon as practicable, but not later than 60 working days after receipt.

(o) The state board, in consultation with the districts, shall establish project approval criteria and guidelines for infrastructure projects consistent with Section 44284 as soon as practicable, but not later than February 15, 2000. The commission shall make draft criteria and guidelines available to the public 45 days before final adoption, and shall hold at least one public meeting to consider public comments before final adoption.

(p) The state board, in consultation with the participating districts, may propose revisions to the criteria and guidelines established pursuant to subdivision (o) as necessary to improve the ability of the program to achieve its goals. A revision may be proposed at any time, or may be proposed in response to a finding made in the annual report on the program published by the state board pursuant to Section 44295. A proposed revision shall be made available to the public 45 days before final adoption of the revision and the commission shall hold at least one public meeting to consider public comments before final adoption of the revision.

(q) This section shall become operative on January 1, 2024.

Added Stats 2004 ch 707 § 10.5 (AB 923), operative January 1, 2015. Amended Stats 2013 ch 401 § 26 (AB 8), effective September 28, 2013, operative January 1, 2024.

## ARTICLE 14

### Funds

Section 44299.1. (First of two; Repealed January 1, 2024) Segregation and administration of fund; Allocation of moneys in fund

Section

44299.1. (Second of two; Operative January 1, 2024) Segregation and administration of fund; Allocation of moneys in fund

44299.2. (Repealed January 1, 2024) Terms and conditions for allocation of funds to local air pollution and air quality management districts

**§ 44299.1. (First of two; Repealed January 1, 2024) Segregation and administration of fund; Allocation of moneys in fund**

(a) To ensure that emission reductions are obtained as needed from pollution sources, any moneys deposited in the fund for use by the program or appropriated to the program shall be segregated and administered as follows:

(1) Not more than 2 percent of the moneys in the fund for use by the program shall be allocated to program support and outreach costs incurred by the state board and the commission directly associated with implementing the program pursuant to this chapter. These funds shall be allocated to the state board and the commission in proportion to total program funds administered by the state board and the commission.

(2) Not more than 2 percent of the moneys in the fund for use by the program shall be allocated to direct program outreach activities. The state board may use these funds for program outreach contracts or may allocate outreach funds to participating districts in proportion to each district's allocation from the program moneys in the fund. The state board shall report on the use of outreach funds in their reports to the Legislature pursuant to Section 44295.

(3) The balance shall be deposited in the fund to be expended to offset added costs of new very low or zero-emission vehicle technologies, and emission reducing repowers, retrofits, and add-on equipment for covered vehicles and engines, and other projects specified in Section 44281.

(b) Moneys in the fund shall be allocated to a district that submits an eligible application to the state board pursuant to Section 44287. The state board shall determine the maximum amount of annual funding from the fund for use by the program that each district may receive. This determination shall be based on the population in each district as well as the relative importance of obtaining covered emission reductions in each district, specifically through the program.

(c) Not more than 5 percent of the moneys allocated pursuant to this chapter to a district with a population of one million or more may be used by the district for indirect costs of implementation of the program, including outreach costs that are subject to the limitation in paragraph (2) of subdivision (a).

(d) Not more than 10 percent of the moneys allocated pursuant to this chapter to a district with a population of less than one million may be used by the district for indirect costs of implementation of the program, including outreach costs that are subject to the limitation in paragraph (2) of subdivision (a).

(e) This section shall remain in effect only until January 1, 2024, and as of that date is repealed, unless a later enacted statute, that is enacted before January 1, 2024, deletes or extends that date.

Added Stats 1999 ch 923 § 2 (AB 1571), effective October 10, 1999. Amended Stats 2004 ch 707 § 11 (AB 923); Stats 2006 ch 627 § 3 (SB

225), effective January 1, 2007, repealed January 1, 2015; Stats 2013 ch 401 § 28 (AB 8), effective September 28, 2013, repealed January 1, 2024.

**§ 44299.1. (Second of two; Operative January 1, 2024) Segregation and administration of fund; Allocation of moneys in fund**

(a) To ensure that emission reductions are obtained as needed from pollution sources, any moneys deposited in the fund for use by the program or appropriated to the program shall be segregated and administered as follows:

(1) Ten percent, not to exceed two million dollars (\$2,000,000), shall be allocated to the infrastructure demonstration project to be used pursuant to Section 44284.

(2) Ten percent shall be deposited in the fund for use by the program to be used to support research, development, demonstration, and commercialization of advanced low-emission technologies for covered sources that show promise of contributing to the goals of the program.

(3) Not more than 2 percent of the moneys in the fund for use by the program shall be allocated to program support and outreach costs incurred by the state board and the commission directly associated with implementing the program pursuant to this chapter. These funds shall be allocated to the state board and the commission in proportion to total program funds administered by the state board and the commission.

(4) Not more than 2 percent of the moneys in the fund for use by the program shall be allocated to direct program outreach activities. The state board may use these funds for program outreach contracts or may allocate outreach funds to participating districts in proportion to each district's allocation from the fund for use by the program. The state board shall report on the use of outreach funds in their reports to the Legislature pursuant to Section 44295.

(5) The balance shall be deposited in the fund for use by the program to be expended to offset added costs of new very low or zero-emission vehicle technologies, and emission reducing repowers, retrofits, and add-on equipment for covered vehicles and engines.

(b) Moneys in the fund for use by the program shall be allocated to a district that submits an eligible application to the state board pursuant to Section 44287. The state board shall determine the maximum amount of annual funding from the fund for use by the program that each district may receive. This determination shall be based on the population in each district as well as the relative importance of obtaining NO<sub>x</sub> reductions in each district, specifically through the program.

(c) This section shall become operative on January 1, 2024.

Added Stats 2004 ch 707 § 11.5 (AB 923), operative January 1, 2015. Amended Stats 2013 ch 401 § 29 (AB 8), effective September 28, 2013, operative January 1, 2024.

**§ 44299.2. (Repealed January 1, 2024) Terms and conditions for allocation of funds to local air pollution and air quality management districts**

Funds shall be allocated to districts, and shall be subject to administrative terms and conditions as follows:

(a) Available funds shall be distributed to districts taking into consideration the population of the area, the severity of the air quality problems experienced by the population, and the historical allocation of the program funds, except that the south coast district shall be allocated a percentage of the total funds available to districts that is proportional to the percentage of the total state population residing within the jurisdictional boundaries of that district. For the purposes of this subdivision, population shall be determined by the state board based on the most recent data provided by the Department of Finance. The allocation to the south coast district shall be subtracted from the total funds available to districts. Each district, except the south coast district, shall be awarded a minimum allocation of two hundred thousand dollars (\$200,000), and the remainder, which shall be known as the "allocation amount," shall be allocated to all districts as follows:

(1) The state board shall distribute 35 percent of the allocation amount to the districts in proportion to the percentage of the total residual state population that resides within each district's boundaries. For purposes of this paragraph, "total residual state population" means the total state population, less the total population that resides within the south coast district.

(2) The state board shall distribute 35 percent of the allocation amount to the districts in proportion to the severity of the air quality problems to which each district's population is exposed. The severity of the exposure shall be calculated as follows:

(A) Each district shall be awarded severity points based on the district's attainment designation and classification, as most recently promulgated by the federal Environmental Protection Agency for the National Ambient Air Quality Standard for ozone averaged over eight hours, as follows:

(i) A district that is designated attainment for the federal eight-hour ozone standard shall be awarded one point.

(ii) A district that is designated nonattainment for the federal eight-hour ozone standard shall be awarded severity points based on classification. Two points shall be awarded for transitional, basic, or marginal classifications, three points for moderate classification, four points for serious classification, five points for severe classification, six points for severe-17 classification, and seven points for extreme classification.

(B) Each district shall be awarded severity points based on the annual diesel particulate emissions in the air basin, as determined by the state board. One point shall be awarded to the district, in increments, for each 1,000 tons of diesel particulate emissions. In making this determination, 0 to 999 tons shall be awarded no points, 1,000 to 1,999 tons shall be awarded one point, 2,000 to 2,999 tons shall be awarded two points, and so forth. If a district encompasses more than one air basin, the air basin with the greatest diesel particulate emissions shall be used to determine the points awarded to the district. The San Diego County Air Pollution Control District and the Imperial County Air Pollution Control District shall be awarded one additional point each to account for annual diesel particulate emissions transported from Mexico.

(C) The points awarded under subparagraphs (A) and (B), shall be added together for each district, and the total shall be multiplied by the population residing within the district boundaries, to yield the local air quality exposure index.

(D) The local air quality exposure index for each district shall be summed together to yield a total state exposure index. Funds shall be allocated under this paragraph to each district in proportion to its local air quality exposure index divided by the total state exposure index.

(3) The state board shall distribute 30 percent of the allocation amount to the districts in proportion to the allocation of funds from the program moneys in the fund, as follows:

(A) Because each district is awarded a minimum allocation pursuant to subdivision (a), there shall be no additional minimum allocation from the program historical allocation funds. The total amount allocated in this way shall be subtracted from total funding previously awarded to the district under the program, and the remainder, which shall be known as directed funds, shall be allocated pursuant to subparagraph (B).

(B) Each district with a population that is greater than or equal to 1 percent of the state's population shall receive an additional allocation based on the population of the district and the district's relative share of emission reduction commitments in the state implementation plan to attain the National Ambient Air Quality Standard for ozone averaged over one hour. This additional allocation shall be calculated as a percentage share of the directed funds for each district, derived using a ratio of each district's share amount to the base amount, which shall be calculated as follows:

(i) The base amount shall be the total program funds allocated by the state board to the districts in the 2002-03 fiscal year, less the total of the funds allocated through the minimum allocation to each district in the 2002-03 fiscal year.

(ii) The share amount shall be the allocation that each district received in the 2002-03 fiscal year, not including the minimum allocation. There shall be one share amount for each district.

(iii) The percentage share shall be calculated for each district by dividing the district's share amount by the base amount, and multiplying the result by the total directed funds available under this subparagraph.

(b) Funds shall be distributed as expeditiously as reasonably practicable, and a report of the distribution shall be made available to the public.

(c) All funds allocated pursuant to this section shall be expended as provided in the guidelines adopted pursuant to Section 44287 within two years from the date of allocation. Funds not expended within the two years shall be returned to the program moneys in the fund within 60 days and shall be subject to further allocation as follows:

(1) Within 30 days of the deadline to return funds, the state board shall notify the districts of the total amount of returned funds available for reallocation, and shall list those districts that request supplemental funds from the reallocation and that are able to expend those funds within one year.

(2) Within 90 days of the deadline to return funds, the state board shall allocate the returned funds to the districts listed pursuant to paragraph (1).

(3) All supplemental funds distributed under this subdivision shall be expended consistent with the program within one year of the date of supplemental allocation. Funds not expended within one year shall be returned to the program moneys in the fund and shall be distributed at the discretion of the state board to districts, taking into consideration each district's ability to expeditiously utilize the remaining funds consistent with the program.

(d) This section shall remain in effect only until January 1, 2024, and as of that date is repealed, unless a later enacted statute, that is enacted before January 1, 2024, deletes or extends that date.

Added Stats 2004 ch 707 § 12 (AB 923), repealed January 1, 2015. Amended Stats 2006 ch 627 § 4 (SB 225), effective January 1, 2007, repealed January 1, 2015; Stats 2013 ch 401 § 30 (AB 8), effective September 28, 2013, repealed January 1, 2024.



# INSURANCE CODE

## DIVISION 1

### General Rules Governing Insurance

#### PART 1

#### The Contract

#### CHAPTER 1

#### Classes of Insurance

##### Section

100. Classes of insurance

116. Automobile

116.5. Express warranty warranting motor vehicle lubricant, treatment, fluid, or additive; When not deemed automobile insurance

116.6. Warranty of a vehicle protection system

##### § 100. Classes of insurance

Insurance in this state is divided into the following classes:

- (1) Life.
- (2) Fire.
- (3) Marine.
- (4) Title.
- (5) Surety.
- (6) Disability.
- (7) Plate glass.
- (8) Liability.
- (9) Workmen's compensation.
- (10) Common carrier liability.
- (11) Boiler and machinery.
- (12) Burglary.
- (13) Credit.
- (14) Sprinkler.
- (15) Team and vehicle.
- (16) Automobile.
- (17) [Reserved]
- (18) Aircraft.
- (19) Mortgage guaranty.
- (19.5) Insolvency.
- (19.6) Legal insurance.
- (20) Miscellaneous.

Enacted Stats 1935 ch 145. Amended Stats 1939 ch 936 § 1; Stats 1961 ch 719 § 2; Stats 1969 ch 1347 § 1, effective September 2, 1969; Stats 1974 ch 1161 § 1; Stats 2012 ch 786 § 3 (AB 2303), effective January 1, 2013.

##### § 116. Automobile

(a) Automobile insurance includes insurance of automobile owners, users, dealers, or others having insurable interests therein, against hazards incident to ownership, maintenance, operation, and use of automobiles, other than loss resulting from accident or physical injury, fatal or nonfatal, to, or death of, any natural person.

(b) Automobile insurance also includes any contract of warranty, or guaranty that promises service, maintenance, parts replacement, repair, money, or any other

indemnity in event of loss of or damage to a motor vehicle or a trailer, as defined by Section 630 of the Vehicle Code, or any part thereof from any cause, including loss of or damage to or loss of use of the motor vehicle or trailer by reason of depreciation, deterioration, wear and tear, use, obsolescence, or breakage if made by a warrantor or guarantor who is doing an insurance business.

(c) Automobile insurance also includes any agreement that promises repair or replacement of a motor vehicle, or part thereof, after a mechanical or electrical breakdown, at either no cost or a reduced cost for the agreement holder. However, automobile insurance does not include a vehicle service contract subject to Part 8 (commencing with Section 12800) of Division 2, or an agreement deemed not to be insurance under that part.

(d) The doing or proposing to do any business in substance equivalent to the business described in this section in a manner designed to evade the provisions of this section is the doing of an insurance business.

Enacted Stats 1935 ch 145. Amended Stats 1961 ch 595 § 1; Stats 1983 ch 1075 § 1; Stats 1985 ch 231 § 1. Amended Stats 1997 ch 824 § 1 (SB 912); Stats 2003 ch 439 § 2 (AB 984), operative July 1, 2004.

##### § 116.5. Express warranty warranting motor vehicle lubricant, treatment, fluid, or additive; When not deemed automobile insurance

An express warranty warranting a motor vehicle lubricant, treatment, fluid, or additive that covers incidental or consequential damage resulting from a failure of the lubricant, treatment, fluid, or additive, shall constitute automobile insurance, unless all of the following requirements are met:

(a) The obligor is the primary manufacturer of the product. For the purpose of this section, "manufacturer" means a person who can prove clearly and convincingly that the per unit cost of owned or leased capital goods, including the factory, used to produce the product, plus the per unit cost of nonsubcontracted labor used to produce the product, exceeds twice the per unit cost of raw materials used to produce the product. "Manufacturer" also means a person who has formulated or produced, and continuously offered in this state for more than nine years, a motor vehicle lubricant, treatment, fluid, or additive.

(b) The commissioner has issued a written determination that the obligor is a manufacturer as defined in subdivision (a). An obligor shall provide the commissioner with all information, documents, and affidavits reasonably necessary for this determination to be made. Approval by the commissioner shall be obtained prior to January 1, 2004, or prior to the issuance of a warranty subject to this section, whichever is later. If the commissioner determines that the obligor is not a manufacturer, the obligor may obtain a hearing in accordance with

Chapter 4.5 (commencing with Section 11400) of Part 1 of Division 3 of Title 2 of the Government Code.

(c) The agreement covers only damage incurred while the product was in the vehicle.

(d) The agreement is provided automatically with the product at no extra charge.

Added Stats 1999 ch 238 § 1 (AB 509). Amended Stats 2003 ch 439 § 3 (AB 984), operative July 1, 2004; Stats 2004 ch 85 § 1 (AB 2904), effective June 30, 2004; Stats 2006 ch 196 § 1 (AB 2815), effective January 1, 2007.

#### § 116.6. Warranty of a vehicle protection system

(a) Notwithstanding Section 116, a warranty issued by the warrantor of a vehicle protection product shall constitute an express warranty, as defined in Section 1791.2 of the Civil Code, and shall not constitute automobile insurance if the warrantor complies with all of the following requirements:

(1) The warrantor maintains an insurance policy with an admitted insurer providing coverage for 100 percent of the warrantor's obligations under the warranty. The insurance policy shall allow the warrantyholder to make a direct claim for payment from the insurer upon the failure of the warrantor to pay any covered claim within 60 days after a complete proof-of-loss has been filed with the party designated in the warranty. In addition, all of the following shall apply:

(A) The warrantor shall file with the commissioner a copy of the insurance policy. At any time, a warrantor may have on file with the commissioner only one active policy from one insurer.

(B) The insurer's liability under the policy shall not be negated by a failure of the warrantor, for any reason, to report the issuance of a warranty to the insurer or to remit moneys owed to the insurer.

(C) No policy cancellation by an insurer shall be valid unless a notice of the intent to cancel the policy is filed with the commissioner not less than 30 days prior to the effective date of the cancellation, or, in the event that the cancellation is due to fraud, material misrepresentation, or defalcation by the warrantor, not less than 10 days prior to that date.

(D) In the event an insurer cancels a policy that a warrantor has filed with the commissioner, the warrantor shall do either of the following:

(i) File a copy of a new policy with the commissioner, before the termination of the prior policy, providing no lapse in coverage following the termination of the prior policy.

(ii) Discontinue acting as a warrantor as of the termination date of the policy until a new policy becomes effective and is accepted by the commissioner.

(2) The warrantor does not use the words insurance, casualty, surety, mutual, or any other words descriptive of the casualty, insurance, or surety business or deceptively similar to the name or description of any insurance company or casualty or surety company in the vehicle protection product name or warranty or in any advertising or other materials provided to prospective purchasers.

(3) The warranty has been issued to a customer that is insured under a comprehensive vehicle insurance policy for the vehicle covered by the warranty agreement.

(4) The warranty is in writing and provides all of the following:

(A) The benefits are limited to the difference between the actual cash value of the stolen vehicle and the vehicle's replacement cost, temporary vehicle rental expenses, reimbursement for insurance policy deductible, and registration fees and taxes on a replacement vehicle or a fixed amount for those benefits.

(B) A statement that the warrantyholder shall be entitled to make a direct claim against the insurer covering the obligations of the warranty upon the failure of the warrantor to pay any covered claim within 60 days after a complete proof-of-loss has been filed with the party designated in the warranty.

(C) A disclosure stating clearly the name, address, and telephone number of the insurer covering the obligations of the warrantor.

(D) A toll-free telephone number established and operated by the warrantor for the warrantyholder to call for questions about the warranty or the procedures to file a claim.

(E) A statement that clearly indicates the terms of the warranty, whether new or used cars are eligible for the vehicle protection product, the method for calculating the benefits paid and provided to the warrantyholder, and the procedure for filing a claim under the warranty.

(F) A disclosure in 10-point type or larger that reads as follows: "This agreement is a product warranty and is not insurance. It is not subject to state insurance laws but is subject to state law concerning warranties."

(G) A disclosure in 10-point type or larger that reads as follows: "To be eligible for this warranty, the warrantyholder must have comprehensive insurance coverage on the vehicle that is protected by the antitheft device."

(5) The benefit is payable upon the theft of the vehicle, as defined in the warranty, and subject to the satisfaction of the procedural proof of claim requirements of the warranty.

(b) For purposes of this section, the following definitions shall apply:

(1) "Warrantor" means the manufacturer or provider of a vehicle protection product who, under the terms of a vehicle protection product warranty, is the contractual obligor to the purchaser of a vehicle protection product.

(2)(A) "Vehicle protection product" means a vehicle protection device, system, or service that is installed on, or applied to, a vehicle, is designed to deter the theft of a vehicle, and includes a written warranty that provides if the product fails to deter the theft of the vehicle, that the warrantyholder shall be paid specified incidental costs by the warrantor as a result of the failure of the device, system, or service to perform pursuant to the terms of the warranty.

(B) For purposes of this section, "vehicle protection product" shall also include alarm systems, window etch products, body part marking products, steering locks, pedal and ignition locks, fuel and ignition kill switches, and electronic, radio, and satellite tracking devices.

(c) The commissioner may issue a stop order pursuant to Section 12921.8 to a warrantor who is in violation of the requirements of this section.

(d) A warrantor shall have the burden of proving that a claim filed in compliance with the terms and conditions of the warranty is not covered by the warranty. A

warrantor shall have the burden of proving that a claim settlement amount fulfills the promises contained in the warranty.

(e) The requirements of this section shall not apply under either of the following conditions:

(1) The warrantor is a manufacturer of motor vehicles, as defined pursuant to Section 672 of the Vehicle Code, or a distributor of motor vehicles, as defined pursuant to Section 296 of the Vehicle Code.

(2) The warranty only provides for the repair or replacement of the vehicle protection product subsequent to a mechanical or electrical breakdown of the vehicle protection product.

(f) Nothing in this section is intended to affect any pending litigation.

Added Stats 2002 ch 749 § 1 (AB 2012).

## PART 2

### The Business of Insurance

#### CHAPTER 1

#### General Regulations

#### ARTICLE 5

#### Unlawful Referrals

Section

750. Unlawful offer or receipt of consideration by claims handlers for referral or procurement of clients; Punishment

#### § 750. Unlawful offer or receipt of consideration by claims handlers for referral or procurement of clients; Punishment

(a) Except as provided in Section 750.5, any person acting individually or through his or her employees or agents, who engages in the practice of processing, presenting, or negotiating claims, including claims under policies of insurance, and who offers, delivers, receives, or accepts any rebate, refund, commission, or other consideration, whether in the form of money or otherwise, as compensation or inducement to or from any person for the referral or procurement of clients, cases, patients, or customers, is guilty of a crime.

(b) A violation of subdivision (a) is punishable upon a first conviction by imprisonment in a county jail for not more than one year, or by imprisonment pursuant to subdivision (h) of Section 1170 of the Penal Code, or by a fine not exceeding fifty thousand dollars (\$50,000), or by both that imprisonment and fine. A second or subsequent conviction is punishable by imprisonment pursuant to subdivision (h) of Section 1170 of the Penal Code or by that imprisonment and a fine of fifty thousand dollars (\$50,000).

(c) Nothing in this section shall prohibit a licensed collection or lien agency from receiving a commission on the collection of delinquent debts nor prohibits the agency from paying its employees a commission for obtaining clients seeking collection on delinquent debts.

(d) Nothing in this section is intended to limit, restrict, or in any way apply to, the rebating of commis-

sions by insurance agents or brokers, as authorized by Proposition 103, enacted by the people at the November 8, 1988, general election.

Added Stats 1991 ch 116 § 9 (SB 1218). Amended Stats 1991 ch 934 § 2 (AB 1673); Stats 1992 ch 1352 § 1 (AB 3660), effective September 30, 1992; Stats 2000 ch 843 § 2 (AB 2594); Stats 2011 ch 15 § 206 (AB 109), effective April 4, 2011, operative October 1, 2011.

## ARTICLE 5.1

### Unlawful Practices

Section

758. Requirement that repair shop pay for rental vehicle

758.5. Requiring automobile to be repaired at specific dealer

#### § 758. Requirement that repair shop pay for rental vehicle

(a) It is unlawful for an insurer to require an auto body repair shop registered pursuant to Sections 9884 and 9889.52 of the Business and Professions Code, as a condition of participation in the insurer's direct repair program, to pay for the cost of an insured's rental vehicle that is replacing an insured vehicle damaged in an accident, or to pay for the towing charges of the insured with respect to that accident. However, the insurer and the auto body repair shop may agree in writing to terms and conditions under which the rental vehicle charges become the responsibility of the auto body repair shop when the shop fails to complete work within the agreed-upon time for repair of the damaged vehicle.

(b) A registered auto body repair shop that is denied participation in an insurer's direct repair program may report a denial to the department, which shall maintain a record of all those denials for the purposes of gathering market conduct information. An insurer, upon the request of the department, shall disclose the fact that a denial was made.

(c) Any insurer that conducts an auto body repair labor rate survey to determine and set a specified prevailing auto body rate in a specific geographic area shall report the results of that survey to the department, which shall make the information available upon request. The survey information shall include the names and addresses of the auto body repair shops and the total number of shops surveyed.

Added Stats 2000 ch 867 § 15 (SB 1988).

#### § 758.5. Requiring automobile to be repaired at specific dealer

(a) No insurer shall require that an automobile be repaired at a specific automotive repair dealer, as defined in Section 9880.1 of the Business and Professions Code.

(b)(1) No insurer shall suggest or recommend that an automobile be repaired at a specific automotive repair dealer unless either of the following applies:

(A) A referral is expressly requested by the claimant.

(B) The claimant has been informed in writing of the right to select the automotive repair dealer.

(2) An insurer may provide the claimant with specific truthful and nondeceptive information regarding the services and benefits available to the claimant during the claims process. This may include, but is not limited to, information about the repair warranties offered, the

type of replacement parts to be used, the anticipated time to repair the damaged vehicle, and the quality of the workmanship available to the claimant.

(3) If an insurer's recommendation of an automotive repair dealer is accepted by the claimant, the insurer shall cause the damaged vehicle to be restored to its condition prior to the loss at no additional cost to the claimant other than as stated in the policy or as is otherwise allowed by law. If the recommendation of an automotive repair dealer is done orally, and if the oral recommendation is accepted by the claimant, the insurer shall provide the information contained in this paragraph, as noted in the statement below, to the claimant at the time the recommendation is made. The insurer shall mail or provide the notice required by this paragraph within five calendar days from the acceptance of the recommendation. The written notice required by this paragraph shall include the following statement plainly printed in no less than 10-point type in a separate and freestanding document:

"WE ARE PROHIBITED BY LAW FROM REQUIRING THAT REPAIRS BE DONE AT A SPECIFIC AUTOMOTIVE REPAIR DEALER. YOU ARE ENTITLED TO SELECT THE AUTO BODY REPAIR SHOP TO REPAIR DAMAGE COVERED BY US. WE HAVE RECOMMENDED AN AUTOMOTIVE REPAIR DEALER THAT WILL REPAIR YOUR DAMAGED VEHICLE. WE RECOMMEND YOU CONTACT ANY OTHER AUTOMOTIVE REPAIR DEALER YOU ARE CONSIDERING TO CLARIFY ANY QUESTIONS YOU MAY HAVE REGARDING SERVICES AND BENEFITS. IF YOU AGREE TO USE OUR RECOMMENDED AUTOMOTIVE REPAIR DEALER, WE WILL CAUSE THE DAMAGED VEHICLE TO BE RESTORED TO ITS CONDITION PRIOR TO THE LOSS AT NO ADDITIONAL COST TO YOU OTHER THAN AS STATED IN THE INSURANCE POLICY OR AS OTHERWISE ALLOWED BY LAW. IF YOU EXPERIENCE A PROBLEM WITH THE REPAIR OF YOUR VEHICLE, PLEASE CONTACT US IMMEDIATELY FOR ASSISTANCE."

(c) Except as provided in subparagraph (A) of paragraph (1) of subdivision (b), or as to information of the kind authorized by paragraph (2) of subdivision (b), after the claimant has chosen an automotive repair dealer, the insurer shall not suggest or recommend that the claimant select a different automotive repair dealer.

(d) Any insurer that, by the insurance contract, suggests or recommends that an automobile be repaired at a particular automotive repair dealer shall also do both of the following:

(1) Prominently disclose the contractual provision in writing to the insured at the time the insurance is applied for and at the time the claim is acknowledged by the insurer.

(2) If the claimant elects to have the vehicle repaired at the shop of his or her choice, the insurer shall not limit or discount the reasonable repair costs based on charges that would have been incurred had the vehicle been repaired by the insurer's chosen shop.

(e) For purposes of this section, "claimant" means a first-party claimant or insured, or a third-party claimant who asserts a right of recovery for automotive repairs under an insurance policy.

(f) The powers of the commissioner to enforce this section shall include those granted in Article 6.5 (commencing with Section 790) of Chapter 1 of Part 2 of Division 1.

(g) The changes to this section made by the act enacted during the 2009-10 Regular Session that amended this section shall only apply to actions filed on or after January 1, 2010.

Added Stats 2003 ch 791 § 1 (SB 551). Amended Stats 2009 ch 387 § 1 (AB 1200), effective January 1, 2010.

## CHAPTER 9

### Rates and Rating and Other Organizations

#### ARTICLE 10

#### Reduction and Control of Insurance Rates

Section 1861.02. Good Driver Discount Policy; Determination of rates and premiums; Criteria

#### § 1861.02. Good Driver Discount Policy; Determination of rates and premiums; Criteria

(a) Rates and premiums for an automobile insurance policy, as described in subdivision (a) of Section 660, shall be determined by application of the following factors in decreasing order of importance:

- (1) The insured's driving safety record.
- (2) The number of miles he or she drives annually.
- (3) The number of years of driving experience the insured has had.

(4) Those other factors that the commissioner may adopt by regulation and that have a substantial relationship to the risk of loss. The regulations shall set forth the respective weight to be given each factor in determining automobile rates and premiums. Notwithstanding any other provision of law, the use of any criterion without approval shall constitute unfair discrimination.

(b)(1) Every person who meets the criteria of Section 1861.025 shall be qualified to purchase a Good Driver Discount policy from the insurer of his or her choice. An insurer shall not refuse to offer and sell a Good Driver Discount policy to any person who meets the standards of this subdivision.

(2) The rate charged for a Good Driver Discount policy shall comply with subdivision (a) and shall be at least 20% below the rate the insured would otherwise have been charged for the same coverage. Rates for Good Driver Discount policies shall be approved pursuant to this article.

(3)(A) This subdivision shall not prevent a reciprocal insurer, organized prior to November 8, 1988, by a motor club holding a certificate of authority under Chapter 2 (commencing with Section 12160) of Part 5 of Division 2, and which requires membership in the motor club as a condition precedent to applying for insurance from requiring membership in the motor club as a condition precedent to obtaining insurance described in this subdivision.

(B) This subdivision shall not prevent an insurer which requires membership in a specified voluntary, nonprofit organization, which was in existence prior to November 8, 1988, as a condition precedent to applying for insurance issued to or through those membership groups, including franchise groups, from requiring such membership as a condition to applying for the coverage offered to members of the group, provided that it or an affiliate also offers and sells coverage to those who are not members of those membership groups.

(C) However, all of the following conditions shall be applicable to the insurance authorized by subparagraphs (A) and (B):

(i) Membership, if conditioned, is conditioned only on timely payment of membership dues and other bona fide criteria not based upon driving record or insurance, provided that membership in a motor club may not be based on residence in any area within the state.

(ii) Membership dues are paid solely for and in consideration of the membership and membership benefits and bear a reasonable relationship to the benefits provided. The amount of the dues shall not depend on whether the member purchases insurance offered by the membership organization. None of those membership dues or any portion thereof shall be transferred by the membership organization to the insurer, or any affiliate of the insurer, attorney-in-fact, subsidiary, or holding company thereof, provided that this provision shall not prevent any bona fide transaction between the membership organization and those entities.

(iii) Membership provides bona fide services or benefits in addition to the right to apply for insurance. Those services shall be reasonably available to all members within each class of membership.

Any insurer that violates clause (i), (ii), or (iii) shall be subject to the penalties set forth in Section 1861.14.

(c) The absence of prior automobile insurance coverage, in and of itself, shall not be a criterion for determining eligibility for a Good Driver Discount policy, or generally for automobile rates, premiums, or insurability. However, notwithstanding subdivision (a), an insurer may use persistency of automobile insurance coverage with the insurer, an affiliate, or another insurer as an optional rating factor. The Legislature hereby finds and declares that it furthers the purpose of Proposition 103 to encourage competition among carriers so that coverage overall will be priced competitively. The Legislature further finds and declares that competition is furthered when insureds are able to claim a discount for regular purchases of insurance from any carrier offering this discount irrespective of whether or not the insured has previously purchased from a given carrier offering the discount. Persistency of coverage may be demonstrated by coverage under the low-cost automobile insurance program pursuant to Article 5.5 (commencing with Section 11629.7) and Article 5.6 (commencing with Section 11629.9) of Chapter 1 of Part 3 of Division 2, or by coverage under the assigned risk plans pursuant to Article 4 (commencing with Section 11620) of Chapter 1 of Part 3 of Division 2. Persistency shall be deemed to exist even if there is a lapse of coverage of up to two years due to an insured's absence from the state while in military service, and up to 90 days in the last five years for any other reason.

(d) An insurer may refuse to sell a Good Driver Discount policy insuring a motorcycle unless all named insureds have been licensed to drive a motorcycle for the previous three years.

(e) This section shall become operative on November 8, 1989. The commissioner shall adopt regulations implementing this section and insurers may submit applications pursuant to this article which comply with those regulations prior to that date, provided that no such application shall be approved prior to that date.

Addition adopted by voters, Prop 103 § 3, effective November 9, 1988. Amended Stats 1989 ch 1099 § 2, effective September 29, 1989, operative November 8, 1989, ch 1465 § 1.5; Stats 2003 ch 169 § 1 (SB 841), effective August 2, 2003.

## CHAPTER 12

### The Insurance Frauds Prevention Act

#### ARTICLE 2

#### Bureau of Fraudulent Claims

Section

1872.1. [Section repealed 2013.]

#### § 1872.1. [Section repealed 2013.]

Added Stats 1989 ch 1119 § 3. Amended Stats 1994 ch 1247 § 2 (AB 1926); Stats 2000 ch 867 § 16 (SB 1988); Stats 2005 ch 717 § 2 (AB 1183). Repealed Stats 2012 ch 728 § 116 (SB 71), effective January 1, 2013, ch 786 § 40, effective January 1, 2013 (ch 786 prevails). The repealed section related to the creation of an advisory committee on automobile insurance fraud and economic automobile theft prevention, investigation, and prosecution.

#### ARTICLE 4.5

#### Insurer Inspections

Section

1874.85. Required inspection

1874.86. Reports to the department

1874.87. Providing insured with Bill of Rights

#### § 1874.85. Required inspection

An insurer that issues automobile liability or collision policies shall inspect vehicles for which it has approved a claim for the cost of auto body repairs, either during the repair process or after the work has been completed, and the number of vehicles inspected shall be a statistical sampling sufficient to demonstrate to the department the insurer's efforts to reduce fraudulent auto body work during a calendar year.

Added Stats 2000 ch 867 § 18 (SB 1988). Amended Stats 2002 ch 664 § 154 (AB 3034).

#### § 1874.86. Reports to the department

Each insurer subject to this article shall report, at the request of the commissioner, but not more than annually, to the department on the following:

(a) The number of vehicles inspected pursuant to Section 1874.85 and the percentage that this number represents of the total number of vehicles for which it paid a claim for the cost of auto body repairs in the prior calendar year.

(b) The results of the inspections, including the nature of any fraud uncovered, and whether or not legal action was pursued.

The department shall make the information provided pursuant to this section available to the California Highway Patrol and the Bureau of Automotive Repair.

Added Stats 2000 ch 867 § 18 (SB 1988). Amended Stats 2010 ch 400 § 27 (AB 2782), effective January 1, 2011.

**§ 1874.87. Providing insured with Bill of Rights**

(a) Each insurer subject to this article shall provide each insured with an Auto Body Repair Consumer Bill of Rights either at the time of application for an automobile insurance policy or following an accident that is reported to the insurer. If the insurer provides the insured with an electronic copy of a policy, the bill of rights may also be transmitted electronically.

(b) The bill of rights shall be a standardized form developed by the department with the purpose of presenting easy-to-read facts for auto insurance consumers. The content of the bill of rights shall be determined by the department, and at a minimum, shall contain information about all of the following:

(1) A consumer's right to select an auto body repair shop for auto body damage covered by the insurance policy and that an insurer may not require this work to be done at a particular auto body repair shop.

(2) The consumer's right to be informed about auto body repairs made with new original equipment crash parts, new aftermarket crash parts, and used crash parts.

(3) The consumer's right to be informed about coverage for towing services, and for a replacement rental vehicle while a damaged vehicle is being repaired.

(4) Toll-free telephone numbers and Internet addresses for reporting suspected fraud or other complaints and concerns about auto body repair shops to the Bureau of Automotive Repair.

(5) A consumer's right to seek and obtain an independent repair estimate directly from a registered auto body repair shop for repair of a damaged vehicle, even when pursuing an insurance claim for repair of that vehicle.

(c) The department shall consult with the Bureau of Automotive Repair in determining the information to be contained in the bill of rights.

Added Stats 2000 ch 867 § 18 (SB 1988). Amended Stats 2009 ch 141 § 1 (AB 1179), effective January 1, 2010.

**ARTICLE 4.6**

**Auto Insurance Fraud Crisis Areas**

Section  
1874.90. Declaration of area

**§ 1874.90. Declaration of area**

The commissioner may declare any region of the state as an auto insurance fraud crisis area upon making a finding that auto insurance fraud is endemic to the area. That declaration of an auto insurance fraud crisis area shall be in effect for not more than two years, unless extended or renewed by the commissioner. Auto insurance fraud is endemic to an area if the commissioner determines that organized automobile fraud activity exists in the area and contributes significantly to the cost of automobile insurance in that area.

Added Stats 2000 ch 867 § 19 (SB 1988).

**DIVISION 2**

**Classes of Insurance**

**PART 8**

**Service Contracts**

Section  
12800. Definitions  
12805. What agreements not to constitute insurance; Exemptions  
12810. Who may offer vehicle service contract to purchaser; Fronting company  
12820. Vehicle service contract form; Filing; Requirements; Certain benefits as insurance  
12825. Right to cancel; Conditions; Liability; Refund

**§ 12800. Definitions**

The following definitions apply for purposes of this part:

(a) "Motor vehicle" means a self-propelled device operated solely or primarily upon land and may include both self-propelled motor homes or recreational vehicles, non-self-propelled camping and recreational trailers, off-road vehicles, and trailers designed to transport off-road vehicles. However, "motor vehicle" shall not include a self-propelled vehicle, or a component part of such a vehicle, that has any of the following characteristics:

(1) Has a gross vehicle weight rating of 30,000 pounds or more, and is not a recreational vehicle as defined by Section 18010 of the Health and Safety Code.

(2) Is designed to transport more than 15 passengers, including the driver.

(3) Is used in the transportation of materials considered hazardous pursuant to the Hazardous Materials Transportation Act (49 U.S.C. Sec. 5101 et seq.), as amended.

(b) "Watercraft" means a vessel, as defined in Section 21 of the Harbors and Navigation Code, and may include any non-self-propelled trailer used to transport such watercraft upon land.

(c)(1) "Vehicle service contract" means a contract or agreement for a separately stated consideration and for a specific duration to repair, replace, or maintain a motor vehicle or watercraft, or to indemnify for the repair, replacement, or maintenance of a motor vehicle or watercraft, necessitated by an operational or structural failure due to a defect in materials or workmanship, or due to normal wear and tear.

(2) A vehicle service contract may also provide for the incidental payment of indemnity under limited circumstances only in the form of the following additional benefits: coverage for towing, substitute transportation, emergency road service, rental car reimbursement, reimbursement of deductible amounts under a manufacturer's warranty, and reimbursement for travel, lodging, or meals.

(3) "Vehicle service contract" also includes an agreement of a term of at least one year, for separately stated consideration, that promises routine maintenance.

(4) Notwithstanding Section 116, and paragraphs (1) and (2) of this subdivision, a vehicle service contract also includes one or more of the following:

(A) An agreement that promises the repair or replacement of a tire or wheel necessitated by wear and tear, defect, or damage caused by a road hazard. However, an agreement that promises the repair or replacement of a tire necessitated by wear and tear, defect, or damage caused by a road hazard, in which the obligor is the tire manufacturer, is exempt from the requirements of this part. A warranty provided by a tire or wheel distributor or retailer is exempt from the requirements of this part as long as the warranty covers only defects in the material or workmanship of the tire or wheel.

(B) An agreement that promises the repair or replacement of glass on a vehicle necessitated by wear and tear, defect, or damage caused by a road hazard. However, a warranty provided by a vehicle glass or glass sealant manufacturer is exempt from the requirements of this part. A warranty provided by a vehicle glass distributor or retailer is exempt from the requirements of this part as long as the warranty covers only defects in the material or workmanship of the vehicle glass.

(C) An agreement that promises the removal of a dent, ding, or crease without affecting the existing paint finish using paintless dent repair techniques, and which expressly excludes the replacement of vehicle body panels, sanding, bonding, or painting.

(d) "Service contract administrator" or "administrator" means any person, other than an obligor, who performs or arranges, directly or indirectly, the collection, maintenance, or disbursement of moneys to compensate any party for claims or repairs pursuant to a vehicle service contract, and who also performs or arranges, directly or indirectly, any of the following activities with respect to vehicle service contracts in which a seller located within this state is the obligor:

(1) Providing sellers with service contract forms.

(2) Participating in the adjustment of claims arising from service contracts.

(e) "Purchaser" means any person who purchases a vehicle service contract from a seller.

(f) "Seller" means either of the following:

(1) With respect to motor vehicles, a dealer or lessor-retailer licensed in one of those capacities by the Department of Motor Vehicles and who sells vehicle service contracts incidental to his or her business of selling or leasing motor vehicles.

(2) With respect to watercraft, a person who sells vehicle service contracts incidental to that person's business of selling or leasing watercraft vehicles.

(g) "Obligor" means the entity legally obligated under the terms of a service contract.

Added Stats 2003 ch 439 § 5 (AB 984), operative July 1, 2004. Amended Stats 2006 ch 196 § 2 (AB 2815), effective January 1, 2007; Stats 2007 ch 326 § 1 (AB 1008), effective January 1, 2008; Stats 2010 ch 543 § 8 (AB 2111), effective January 1, 2011.

### § 12805. What agreements not to constitute insurance; Exemptions

(a) Notwithstanding Sections 103 and 116, the following types of agreements shall not constitute insurance:

(1) A vehicle service contract that does each of the following:

(A) Names as the obligor a motor vehicle manufacturer or distributor licensed in that capacity by the Department of Motor Vehicles, or a watercraft manufacturer.

(B) Covers only motor vehicles or watercraft manufactured, distributed, or sold by that obligor.

(2) A vehicle service contract in which the obligor is a seller, provided that the obligor complies with all provisions of this part except Section 12815.

(3) A vehicle service contract sold by a seller in which the obligor is a party other than the seller, provided that the obligor complies with all provisions of this part.

(4) An agreement in which the obligor is a motor vehicle or watercraft part manufacturer, distributor, or retailer, that covers no more than the following items:

(A) The repair or replacement of a part manufactured, distributed, or retailed by that obligor.

(B) Consequential and incidental damage resulting from the failure of that part.

(5) An agreement in which the obligor is a repair facility, that is entered into pursuant and subsequent to repair work previously performed by that repair facility, and that is limited in scope to the following:

(A) The repair or replacement of the part that was previously repaired.

(B) Consequential and incidental damage resulting from the failure of that part.

(6) An agreement promising only routine maintenance that does not constitute a vehicle service contract.

(b) The types of agreements described in paragraphs (4), (5), and (6) of subdivision (a) are exempt from all provisions of this part.

(c) Vehicle service contracts described in paragraph (1) of subdivision (a) are exempt from the provisions of Sections 12815, 12830, 12835, and 12845.

Added Stats 2003 ch 439 § 5 (AB 984), operative July 1, 2004. Amended Stats 2007 ch 326 § 2 (AB 1008), effective January 1, 2008.

### § 12810. Who may offer vehicle service contract to purchaser; Fronting company

(a) No person, other than a seller, shall sell or offer for sale a vehicle service contract to a purchaser.

(b) No obligor shall use a seller as a fronting company and no seller shall act as a fronting company. For purposes of this section, a "fronting company" is a seller that authorizes a third-party obligor to use its name or business to evade or circumvent the provisions of subdivision (a).

Added Stats 2003 ch 439 § 5 (AB 984), operative July 1, 2004.

### § 12820. Vehicle service contract form; Filing; Requirements; Certain benefits as insurance

(a) Prior to offering a vehicle service contract form to a purchaser or providing a vehicle service contract form to a seller, an obligor shall file with the commissioner a specimen of that vehicle service contract form.

(b) A vehicle service contract form may include any or all of the benefits described in subdivision (c) of Section 12800 and shall comply with all of the following requirements:

(1)(A) If an obligor has complied with Section 12830, the vehicle service contract shall include a disclosure in

substantially the following form: "Performance to you under this contract is guaranteed by a California approved insurance company. You may file a claim with this insurance company if any promise made in the contract has been denied or has not been honored within 60 days after your request. The name and address of the insurance company is: (insert name and address). If you are not satisfied with the insurance company's response, you may contact the California Department of Insurance at 1-800-927-4357."

(B) If an obligor has complied with Section 12836, the vehicle service contract shall include a disclosure in substantially the following form: "If any promise made in the contract has been denied or has not been honored within 60 days after your request, you may contact the California Department of Insurance at 1-800-927-4357."

(2) All vehicle service contract language that excludes coverage, or imposes duties upon the purchaser, shall be conspicuously printed in boldface type no smaller than the surrounding type.

(3) The vehicle service contract shall do each of the following:

(A) State the obligor's full corporate name or a fictitious name approved by the commissioner, the obligor's mailing address, the obligor's telephone number, and the obligor's vehicle service contract provider license number.

(B) State the name of the purchaser and the name of the seller.

(C) Conspicuously state the vehicle service contract's purchase price.

(D) Comply with Sections 1794.4 and 1794.41 of the Civil Code.

(E) Name the administrator, if any, and provide the administrator's license number.

(4) If the vehicle service contract excludes coverage for preexisting conditions, the contract must disclose this exclusion in 12-point type.

(c) The following benefits constitute insurance, whether offered as part of a vehicle service contract or in a separate agreement:

(1) Indemnification for a loss caused by misplacement, theft, collision, fire, or other peril typically covered in the comprehensive coverage section of an automobile insurance policy, a homeowner's policy, or a marine or inland marine policy.

(2) Locksmith services, unless offered as part of an emergency road service benefit.

Added Stats 2003 ch 439 § 5 (AB 984), operative July 1, 2004. Amended Stats 2007 ch 326 § 3 (AB 1008), effective January 1, 2008.

### § 12825. Right to cancel; Conditions; Liability; Refund

(a) In addition to any other right of rescission an obligor or purchaser may have, an obligor may include a

provision in a service contract that reserves to the obligor the right to cancel the service contract within 60 days under the following conditions:

(1) Notice of cancellation is mailed to the purchaser postmarked before the 61st day after the date the contract was sold by the seller.

(2) The obligor provides the purchaser with a refund equal to the full purchase price stated on the contract within 30 days from the date of cancellation. However, if the obligor has paid a claim, or has advised the purchaser in writing that it will pay a claim, it may provide a pro rata refund, less the amount of any claims paid prior to cancellation.

(3) The service contract ceases to be valid no less than five days after the postmark date of the notice.

(4) The notice states the specific grounds for the cancellation.

(b) An obligor may at any time cancel a service contract for nonpayment by the purchaser, conditioned upon each of the following:

(1) Notice of cancellation is mailed to the purchaser.

(2) If any refund is owed pursuant to Section 1794.41 of the Civil Code, the refund is paid within 30 days of the date of cancellation.

(3) The service contract ceases to be valid no less than five days after the postmark date of the notice.

(4) The notice states the specific grounds for the cancellation.

(c) An obligor may at any time cancel a service contract for material misrepresentation or fraud by the purchaser, conditioned upon each of the following:

(1) Notice of cancellation is mailed to the purchaser.

(2) A pro rata refund of the purchase price stated on the contract is paid within 30 days of the date of cancellation.

(3) The notice states the specific nature of the misrepresentation.

(d) An obligor who cancels a contract is liable for any claim reported to a person designated in the contract for the reporting of claims if the claim is reported prior to the effective date of cancellation and is covered by the contract. For the purpose of this subdivision, a purchaser is deemed to have reported a claim if he or she has completed the first step required under the contract for reporting a claim.

(e) An obligor canceling a contract pursuant to subdivision (b), (c), or (d) who pays a claim, or has advised the purchaser in writing that he or she will pay a claim, may provide a prorata rather than full refund, less the amount of any claims paid prior to cancellation.

Added Stats 2003 ch 439 § 5 (AB 984), operative July 1, 2004.



# PENAL CODE

## PRELIMINARY PROVISIONS

Section

20. To constitute crime there must be unity of act and intent

23. Proceeding against person holding license to engage in business or profession; Appearance of state agency

### **§ 20. To constitute crime there must be unity of act and intent**

In every crime or public offense there must exist a union, or joint operation of act and intent, or criminal negligence.

Enacted 1872.

### **§ 23. Proceeding against person holding license to engage in business or profession; Appearance of state agency**

In any criminal proceeding against a person who has been issued a license to engage in a business or profession by a state agency pursuant to provisions of the Business and Professions Code or the Education Code, or the Chiropractic Initiative Act, the state agency which

issued the license may voluntarily appear to furnish pertinent information, make recommendations regarding specific conditions of probation, or provide any other assistance necessary to promote the interests of justice and protect the interests of the public, or may be ordered by the court to do so, if the crime charged is substantially related to the qualifications, functions, or duties of a licensee.

For purposes of this section, the term "license" shall include a permit or a certificate issued by a state agency.

For purposes of this section, the term "state agency" shall include any state board, commission, bureau, or division created pursuant to the provisions of the Business and Professions Code, the Education Code, or the Chiropractic Initiative Act to license and regulate individuals who engage in certain businesses and professions.

Added Stats 1979 ch 1013 § 34. Amended Stats 1989 ch 388 § 6; Stats 2002 ch 545 § 3 (SB 1852).

## PART 1

### Of Crimes and Punishments

#### TITLE 7

#### Of Crimes Against Public Justice

#### CHAPTER 4

#### Forging, Stealing, Mutilating, and Falsifying Judicial and Public Records and Documents

Section

115. Offering false or forged instruments for filing

### **§ 115. Offering false or forged instruments for filing**

(a) Every person who knowingly procures or offers any false or forged instrument to be filed, registered, or recorded in any public office within this state, which instrument, if genuine, might be filed, registered, or recorded under any law of this state or of the United States, is guilty of a felony.

(b) Each instrument which is procured or offered to be filed, registered, or recorded in violation of subdivision (a) shall constitute a separate violation of this section.

(c) Except in unusual cases where the interests of justice would best be served if probation is granted, probation shall not be granted to, nor shall the execution or imposition of sentence be suspended for, any of the following persons:

(1) Any person with a prior conviction under this section who is again convicted of a violation of this section in a separate proceeding.

(2) Any person who is convicted of more than one violation of this section in a single proceeding, with intent to defraud another, and where the violations resulted in a cumulative financial loss exceeding one hundred thousand dollars (\$100,000).

(d) For purposes of prosecution under this section, each act of procurement or of offering a false or forged instrument to be filed, registered, or recorded shall be considered a separately punishable offense.

Enacted 1872. Amended Stats 1984 ch 593 § 1, ch 1397 § 8; Stats 1985 ch 106 § 106.

#### CHAPTER 5

#### Perjury and Subornation of Perjury

Section

118. Perjury defined

126. Punishment for perjury

127. Subornation of perjury

### **§ 118. Perjury defined**

(a) Every person who, having taken an oath that he or she will testify, declare, depose, or certify truly before any competent tribunal, officer, or person, in any of the cases in which the oath may by law of the State of California be administered, willfully and contrary to the oath, states as true any material matter which he or she knows to be false, and every person who testifies, declares, deposes, or certifies under penalty of perjury in any of the cases in which the testimony, declarations, depositions, or certification is permitted by law of the

State of California under penalty of perjury and willfully states as true any material matter which he or she knows to be false, is guilty of perjury.

This subdivision is applicable whether the statement, or the testimony, declaration, deposition, or certification is made or subscribed within or without the State of California.

(b) No person shall be convicted of perjury where proof of falsity rests solely upon contradiction by testimony of a single person other than the defendant. Proof of falsity may be established by direct or indirect evidence.

Enacted 1872. Amended Stats 1955 ch 873 § 2; Stats 1957 ch 1612 § 2; Stats 1980 ch 889 § 3; Stats 1989 ch 897 § 13; Stats 1990 ch 950 § 2 (SB 2681).

**§ 126. Punishment for perjury**

Perjury is punishable by imprisonment pursuant to subdivision (h) of Section 1170 for two, three or four years.

Enacted 1872. Amended Stats 1976 ch 1139 § 118, operative July 1, 1977; Stats 2011 ch 15 § 249 (AB 109), effective April 4, 2011, operative October 1, 2011.

**§ 127. Subornation of perjury**

Every person who willfully procures another person to commit perjury is guilty of subornation of perjury, and is punishable in the same manner as he would be if personally guilty of the perjury so procured.

Enacted 1872.

**CHAPTER 6**

**Falsifying Evidence, and Bribing, Influencing, Intimidating or Threatening Witnesses**

Section

131. Willful misrepresentation in connection with investigation relating to corporate securities, commodities, or business activities

**§ 131. Willful misrepresentation in connection with investigation relating to corporate securities, commodities, or business activities**

Every person in any matter under investigation for a violation of the Corporate Securities Law of 1968 (Part 1 (commencing with Section 25000) of Division 1 of Title 4 of the Corporations Code), the California Commodity Law of 1990 (Chapter 1 (commencing with Section 29500) of Division 4.5 of Title 4 of the Corporations Code), Section 16755 of the Business and Professions Code, or in connection with an investigation conducted by the head of a department of the State of California relating to the business activities and subjects under the jurisdiction of the department, who knowingly and willfully falsifies, misrepresents, or conceals a material fact or makes any materially false, fictitious, misleading, or fraudulent statement or representation, and any person who knowingly and willfully procures or causes another to violate this section, is guilty of a misdemeanor punishable by imprisonment in a county jail not exceeding one year, or by a fine not exceeding twenty-five thousand dollars (\$25,000), or by both that imprisonment and fine for each violation of this section. This section does not

apply to conduct charged as a violation of Section 118 of this code.

Added Stats 2003 ch 876 § 14 (SB 434).

**TITLE 13**

**Of Crimes Against Property**

**CHAPTER 5**

**Larceny**

Section

502. Computer crimes

**§ 502. Computer crimes**

(a) It is the intent of the Legislature in enacting this section to expand the degree of protection afforded to individuals, businesses, and governmental agencies from tampering, interference, damage, and unauthorized access to lawfully created computer data and computer systems. The Legislature finds and declares that the proliferation of computer technology has resulted in a concomitant proliferation of computer crime and other forms of unauthorized access to computers, computer systems, and computer data.

The Legislature further finds and declares that protection of the integrity of all types and forms of lawfully created computers, computer systems, and computer data is vital to the protection of the privacy of individuals as well as to the well-being of financial institutions, business concerns, governmental agencies, and others within this state that lawfully utilize those computers, computer systems, and data.

(b) For the purposes of this section, the following terms have the following meanings:

(1) "Access" means to gain entry to, instruct, or communicate with the logical, arithmetical, or memory function resources of a computer, computer system, or computer network.

(2) "Computer network" means any system that provides communications between one or more computer systems and input/output devices including, but not limited to, display terminals and printers connected by telecommunication facilities.

(3) "Computer program or software" means a set of instructions or statements, and related data, that when executed in actual or modified form, cause a computer, computer system, or computer network to perform specified functions.

(4) "Computer services" includes, but is not limited to, computer time, data processing, or storage functions, or other uses of a computer, computer system, or computer network.

(5) "Computer system" means a device or collection of devices, including support devices and excluding calculators that are not programmable and capable of being used in conjunction with external files, one or more of which contain computer programs, electronic instructions, input data, and output data, that performs functions including, but not limited to, logic, arithmetic, data storage and retrieval, communication, and control.

(6) "Data" means a representation of information, knowledge, facts, concepts, computer software, computer

programs or instructions. Data may be in any form, in storage media, or as stored in the memory of the computer or in transit or presented on a display device.

(7) "Supporting documentation" includes, but is not limited to, all information, in any form, pertaining to the design, construction, classification, implementation, use, or modification of a computer, computer system, computer network, computer program, or computer software, which information is not generally available to the public and is necessary for the operation of a computer, computer system, computer network, computer program, or computer software.

(8) "Injury" means any alteration, deletion, damage, or destruction of a computer system, computer network, computer program, or data caused by the access, or the denial of access to legitimate users of a computer system, network, or program.

(9) "Victim expenditure" means any expenditure reasonably and necessarily incurred by the owner or lessee to verify that a computer system, computer network, computer program, or data was or was not altered, deleted, damaged, or destroyed by the access.

(10) "Computer contaminant" means any set of computer instructions that are designed to modify, damage, destroy, record, or transmit information within a computer, computer system, or computer network without the intent or permission of the owner of the information. They include, but are not limited to, a group of computer instructions commonly called viruses or worms, that are self-replicating or self-propagating and are designed to contaminate other computer programs or computer data, consume computer resources, modify, destroy, record, or transmit data, or in some other fashion usurp the normal operation of the computer, computer system, or computer network.

(11) "Internet domain name" means a globally unique, hierarchical reference to an Internet host or service, assigned through centralized Internet naming authorities, comprising a series of character strings separated by periods, with the rightmost character string specifying the top of the hierarchy.

(c) Except as provided in subdivision (h), any person who commits any of the following acts is guilty of a public offense:

(1) Knowingly accesses and without permission alters, damages, deletes, destroys, or otherwise uses any data, computer, computer system, or computer network in order to either (A) devise or execute any scheme or artifice to defraud, deceive, or extort, or (B) wrongfully control or obtain money, property, or data.

(2) Knowingly accesses and without permission takes, copies, or makes use of any data from a computer, computer system, or computer network, or takes or copies any supporting documentation, whether existing or residing internal or external to a computer, computer system, or computer network.

(3) Knowingly and without permission uses or causes to be used computer services.

(4) Knowingly accesses and without permission adds, alters, damages, deletes, or destroys any data, computer software, or computer programs which reside or exist internal or external to a computer, computer system, or computer network.

(5) Knowingly and without permission disrupts or causes the disruption of computer services or denies or causes the denial of computer services to an authorized user of a computer, computer system, or computer network.

(6) Knowingly and without permission provides or assists in providing a means of accessing a computer, computer system, or computer network in violation of this section.

(7) Knowingly and without permission accesses or causes to be accessed any computer, computer system, or computer network.

(8) Knowingly introduces any computer contaminant into any computer, computer system, or computer network.

(9) Knowingly and without permission uses the Internet domain name of another individual, corporation, or entity in connection with the sending of one or more electronic mail messages, and thereby damages or causes damage to a computer, computer system, or computer network.

(d)(1) Any person who violates any of the provisions of paragraph (1), (2), (4), or (5) of subdivision (c) is punishable by a fine not exceeding ten thousand dollars (\$10,000), or by imprisonment pursuant to subdivision (h) of Section 1170 for 16 months, or two or three years, or by both that fine and imprisonment, or by a fine not exceeding five thousand dollars (\$5,000), or by imprisonment in a county jail not exceeding one year, or by both that fine and imprisonment.

(2) Any person who violates paragraph (3) of subdivision (c) is punishable as follows:

(A) For the first violation that does not result in injury, and where the value of the computer services used does not exceed nine hundred fifty dollars (\$950), by a fine not exceeding five thousand dollars (\$5,000), or by imprisonment in a county jail not exceeding one year, or by both that fine and imprisonment.

(B) For any violation that results in a victim expenditure in an amount greater than five thousand dollars (\$5,000) or in an injury, or if the value of the computer services used exceeds nine hundred fifty dollars (\$950), or for any second or subsequent violation, by a fine not exceeding ten thousand dollars (\$10,000), or by imprisonment pursuant to subdivision (h) of Section 1170 for 16 months, or two or three years, or by both that fine and imprisonment, or by a fine not exceeding five thousand dollars (\$5,000), or by imprisonment in a county jail not exceeding one year, or by both that fine and imprisonment.

(3) Any person who violates paragraph (6) or (7) of subdivision (c) is punishable as follows:

(A) For a first violation that does not result in injury, an infraction punishable by a fine not exceeding one thousand dollars (\$1,000).

(B) For any violation that results in a victim expenditure in an amount not greater than five thousand dollars (\$5,000), or for a second or subsequent violation, by a fine not exceeding five thousand dollars (\$5,000), or by imprisonment in a county jail not exceeding one year, or by both that fine and imprisonment.

(C) For any violation that results in a victim expenditure in an amount greater than five thousand dollars (\$5,000), by a fine not exceeding ten thousand dollars

(\$10,000), or by imprisonment pursuant to subdivision (h) of Section 1170 for 16 months, or two or three years, or by both that fine and imprisonment, or by a fine not exceeding five thousand dollars (\$5,000), or by imprisonment in a county jail not exceeding one year, or by both that fine and imprisonment.

(4) Any person who violates paragraph (8) of subdivision (c) is punishable as follows:

(A) For a first violation that does not result in injury, a misdemeanor punishable by a fine not exceeding five thousand dollars (\$5,000), or by imprisonment in a county jail not exceeding one year, or by both that fine and imprisonment.

(B) For any violation that results in injury, or for a second or subsequent violation, by a fine not exceeding ten thousand dollars (\$10,000), or by imprisonment in a county jail not exceeding one year, or by imprisonment pursuant to subdivision (h) of Section 1170, or by both that fine and imprisonment.

(5) Any person who violates paragraph (9) of subdivision (c) is punishable as follows:

(A) For a first violation that does not result in injury, an infraction punishable by a fine not one thousand dollars.

(B) For any violation that results in injury, or for a second or subsequent violation, by a fine not exceeding five thousand dollars (\$5,000), or by imprisonment in a county jail not exceeding one year, or by both that fine and imprisonment.

(e)(1) In addition to any other civil remedy available, the owner or lessee of the computer, computer system, computer network, computer program, or data who suffers damage or loss by reason of a violation of any of the provisions of subdivision (c) may bring a civil action against the violator for compensatory damages and injunctive relief or other equitable relief. Compensatory damages shall include any expenditure reasonably and necessarily incurred by the owner or lessee to verify that a computer system, computer network, computer program, or data was or was not altered, damaged, or deleted by the access. For the purposes of actions authorized by this subdivision, the conduct of an unemancipated minor shall be imputed to the parent or legal guardian having control or custody of the minor, pursuant to the provisions of Section 1714.1 of the Civil Code.

(2) In any action brought pursuant to this subdivision the court may award reasonable attorney's fees.

(3) A community college, state university, or academic institution accredited in this state is required to include computer-related crimes as a specific violation of college or university student conduct policies and regulations that may subject a student to disciplinary sanctions up to and including dismissal from the academic institution. This paragraph shall not apply to the University of California unless the Board of Regents adopts a resolution to that effect.

(4) In any action brought pursuant to this subdivision for a willful violation of the provisions of subdivision (c), where it is proved by clear and convincing evidence that a defendant has been guilty of oppression, fraud, or malice as defined in subdivision (c) of Section 3294 of the Civil Code, the court may additionally award punitive or exemplary damages.

(5) No action may be brought pursuant to this subdivision unless it is initiated within three years of the date of the act complained of, or the date of the discovery of the damage, whichever is later.

(f) This section shall not be construed to preclude the applicability of any other provision of the criminal law of this state which applies or may apply to any transaction, nor shall it make illegal any employee labor relations activities that are within the scope and protection of state or federal labor laws.

(g) Any computer, computer system, computer network, or any software or data, owned by the defendant, that is used during the commission of any public offense described in subdivision (c) or any computer, owned by the defendant, which is used as a repository for the storage of software or data illegally obtained in violation of subdivision (c) shall be subject to forfeiture, as specified in Section 502.01.

(h)(1) Subdivision (c) does not apply to punish any acts which are committed by a person within the scope of his or her lawful employment. For purposes of this section, a person acts within the scope of his or her employment when he or she performs acts which are reasonably necessary to the performance of his or her work assignment.

(2) Paragraph (3) of subdivision (c) does not apply to penalize any acts committed by a person acting outside of his or her lawful employment, provided that the employee's activities do not cause an injury, as defined in paragraph (8) of subdivision (b), to the employer or another, or provided that the value of supplies or computer services, as defined in paragraph (4) of subdivision (b), which are used does not exceed an accumulated total of two hundred fifty dollars (\$250).

(i) No activity exempted from prosecution under paragraph (2) of subdivision (h) which incidentally violates paragraph (2), (4), or (7) of subdivision (c) shall be prosecuted under those paragraphs.

(j) For purposes of bringing a civil or a criminal action under this section, a person who causes, by any means, the access of a computer, computer system, or computer network in one jurisdiction from another jurisdiction is deemed to have personally accessed the computer, computer system, or computer network in each jurisdiction.

(k) In determining the terms and conditions applicable to a person convicted of a violation of this section the court shall consider the following:

(1) The court shall consider prohibitions on access to and use of computers.

(2) Except as otherwise required by law, the court shall consider alternate sentencing, including community service, if the defendant shows remorse and recognition of the wrongdoing, and an inclination not to repeat the offense.

Added Stats 1987 ch 1499 § 3. Amended Stats 1989 ch 1076 § 1, ch 1110 § 1, ch 1357 § 1.3; Stats 1998 ch 863 § 3 (AB 1629); Stats 1999 ch 254 § 3 (AB 451); Stats 2000 ch 634 § 1 (AB 2232), ch 635 § 2 (AB 2727); Stats 2009 ch 70 § 1 (AB 22), effective January 1, 2010; Stats 2009–2010 3d Ex Sess ch 28 § 26 (SB 18XXX), effective January 25, 2010; Stats 2011 ch 15 § 378 (AB 109), effective April 4, 2011, operative October 1, 2011.

## CHAPTER 10

### Crimes Against Insured Property and Insurers

Section  
550. Unlawful acts related to claims

## Section

551. Referral to automotive repair dealer for consideration; Discounts intended to offset deductible

**§ 550. Unlawful acts related to claims**

(a) It is unlawful to do any of the following, or to aid, abet, solicit, or conspire with any person to do any of the following:

(1) Knowingly present or cause to be presented any false or fraudulent claim for the payment of a loss or injury, including payment of a loss or injury under a contract of insurance.

(2) Knowingly present multiple claims for the same loss or injury, including presentation of multiple claims to more than one insurer, with an intent to defraud.

(3) Knowingly cause or participate in a vehicular collision, or any other vehicular accident, for the purpose of presenting any false or fraudulent claim.

(4) Knowingly present a false or fraudulent claim for the payments of a loss for theft, destruction, damage, or conversion of a motor vehicle, a motor vehicle part, or contents of a motor vehicle.

(5) Knowingly prepare, make, or subscribe any writing, with the intent to present or use it, or to allow it to be presented, in support of any false or fraudulent claim.

(6) Knowingly make or cause to be made any false or fraudulent claim for payment of a health care benefit.

(7) Knowingly submit a claim for a health care benefit that was not used by, or on behalf of, the claimant.

(8) Knowingly present multiple claims for payment of the same health care benefit with an intent to defraud.

(9) Knowingly present for payment any undercharges for health care benefits on behalf of a specific claimant unless any known overcharges for health care benefits for that claimant are presented for reconciliation at that same time.

(10) For purposes of paragraphs (6) to (9), inclusive, a claim or a claim for payment of a health care benefit also means a claim or claim for payment submitted by or on the behalf of a provider of any workers' compensation health benefits under the Labor Code.

(b) It is unlawful to do, or to knowingly assist or conspire with any person to do, any of the following:

(1) Present or cause to be presented any written or oral statement as part of, or in support of or opposition to, a claim for payment or other benefit pursuant to an insurance policy, knowing that the statement contains any false or misleading information concerning any material fact.

(2) Prepare or make any written or oral statement that is intended to be presented to any insurer or any insurance claimant in connection with, or in support of or opposition to, any claim or payment or other benefit pursuant to an insurance policy, knowing that the statement contains any false or misleading information concerning any material fact.

(3) Conceal, or knowingly fail to disclose the occurrence of, an event that affects any person's initial or continued right or entitlement to any insurance benefit or payment, or the amount of any benefit or payment to which the person is entitled.

(4) Prepare or make any written or oral statement, intended to be presented to any insurer or producer for the purpose of obtaining a motor vehicle insurance

policy, that the person to be the insured resides or is domiciled in this state when, in fact, that person resides or is domiciled in a state other than this state.

(c)(1) Every person who violates paragraph (1), (2), (3), (4), or (5) of subdivision (a) is guilty of a felony punishable by imprisonment pursuant to subdivision (h) of Section 1170 for two, three, or five years, and by a fine not exceeding fifty thousand dollars (\$50,000), or double the amount of the fraud, whichever is greater.

(2) Every person who violates paragraph (6), (7), (8), or (9) of subdivision (a) is guilty of a public offense.

(A) When the claim or amount at issue exceeds nine hundred fifty dollars (\$950), the offense is punishable by imprisonment pursuant to subdivision (h) of Section 1170 for two, three, or five years, or by a fine not exceeding fifty thousand dollars (\$50,000) or double the amount of the fraud, whichever is greater, or by both that imprisonment and fine, or by imprisonment in a county jail not to exceed one year, by a fine of not more than ten thousand dollars (\$10,000), or by both that imprisonment and fine.

(B) When the claim or amount at issue is nine hundred fifty dollars (\$950) or less, the offense is punishable by imprisonment in a county jail not to exceed six months, or by a fine of not more than one thousand dollars (\$1,000), or by both that imprisonment and fine, unless the aggregate amount of the claims or amount at issue exceeds nine hundred fifty dollars (\$950) in any 12-consecutive-month period, in which case the claims or amounts may be charged as in subparagraph (A).

(3) Every person who violates paragraph (1), (2), (3), or (4) of subdivision (b) shall be punished by imprisonment pursuant to subdivision (h) of Section 1170 for two, three, or five years, or by a fine not exceeding fifty thousand dollars (\$50,000) or double the amount of the fraud, whichever is greater, or by both that imprisonment and fine, or by imprisonment in a county jail not to exceed one year, or by a fine of not more than ten thousand dollars (\$10,000), or by both that imprisonment and fine.

(4) Restitution shall be ordered for a person convicted of violating this section, including restitution for any medical evaluation or treatment services obtained or provided. The court shall determine the amount of restitution and the person or persons to whom the restitution shall be paid.

(d) Notwithstanding any other provision of law, probation shall not be granted to, nor shall the execution or imposition of a sentence be suspended for, any adult person convicted of felony violations of this section who previously has been convicted of felony violations of this section or Section 548, or of Section 1871.4 of the Insurance Code, or former Section 556 of the Insurance Code, or former Section 1871.1 of the Insurance Code as an adult under charges separately brought and tried two or more times. The existence of any fact that would make a person ineligible for probation under this subdivision shall be alleged in the information or indictment, and either admitted by the defendant in an open court, or found to be true by the jury trying the issue of guilt or by the court where guilt is established by plea of guilty or nolo contendere or by trial by the court sitting without a jury.

Except when the existence of the fact was not admitted or found to be true or the court finds that a prior felony conviction was invalid, the court shall not strike or dismiss any prior felony convictions alleged in the information or indictment.

This subdivision does not prohibit the adjournment of criminal proceedings pursuant to Division 3 (commencing with Section 3000) or Division 6 (commencing with Section 6000) of the Welfare and Institutions Code.

(e) Except as otherwise provided in subdivision (f), any person who violates subdivision (a) or (b) and who has a prior felony conviction of an offense set forth in either subdivision (a) or (b), in Section 548, in Section 1871.4 of the Insurance Code, in former Section 556 of the Insurance Code, or in former Section 1871.1 of the Insurance Code shall receive a two-year enhancement for each prior felony conviction in addition to the sentence provided in subdivision (c). The existence of any fact that would subject a person to a penalty enhancement shall be alleged in the information or indictment and either admitted by the defendant in open court, or found to be true by the jury trying the issue of guilt or by the court where guilt is established by plea of guilty or nolo contendere or by trial by the court sitting without a jury. Any person who violates this section shall be subject to appropriate orders of restitution pursuant to Section 13967 of the Government Code.

(f) Any person who violates paragraph (3) of subdivision (a) and who has two prior felony convictions for a violation of paragraph (3) of subdivision (a) shall receive a five-year enhancement in addition to the sentence provided in subdivision (c). The existence of any fact that would subject a person to a penalty enhancement shall be alleged in the information or indictment and either admitted by the defendant in open court, or found to be true by the jury trying the issue of guilt or by the court where guilt is established by plea of guilty or nolo contendere or by trial by the court sitting without a jury.

(g) Except as otherwise provided in Section 12022.7, any person who violates paragraph (3) of subdivision (a) shall receive a two-year enhancement for each person other than an accomplice who suffers serious bodily injury resulting from the vehicular collision or accident in a violation of paragraph (3) of subdivision (a).

(h) This section shall not be construed to preclude the applicability of any other provision of criminal law or equitable remedy that applies or may apply to any act committed or alleged to have been committed by a person.

(i) Any fine imposed pursuant to this section shall be doubled if the offense was committed in connection with any claim pursuant to any automobile insurance policy in an auto insurance fraud crisis area designated by the Insurance Commissioner pursuant to Article 4.6 (commencing with Section 1874.90) of Chapter 12 of Part 2 of Division 1 of the Insurance Code.

Added Stats 1992 ch 675 § 8 (AB 3067). Amended Stats 1993 ch 120 § 8 (AB 1300), effective July 16, 1993, ch 605 § 3 (AB 1179); Stats 1994 ch 841 § 3 (AB 3751), ch 1008 § 3.1 (SB 1833); Stats 1995 ch 573 § 2 (SB 1228), effective October 4, 1995, ch 574 § 4 (SB 465); Stats 1998 ch 189 § 1 (SB 334); Stats 1999 ch 83 § 143 (SB 966); Stats 2000 ch 867 § 21 (SB 1988); Stats 4th Ex Sess 2003-2004 ch 2 § 6 (SB 2XXXX), effective March 6, 2005; Stats 2009-2010 3d Ex Sess ch 28 § 29 (SB 18XXX), effective January 25, 2010; Stats 2011 ch 15 § 392 (AB 109), effective April 4, 2011, operative October 1, 2011.

### § 551. Referral to automotive repair dealer for consideration; Discounts intended to offset deductible

(a) It is unlawful for any automotive repair dealer, contractor, or employees or agents thereof to offer to any insurance agent, broker, or adjuster any fee, commission, profit sharing, or other form of direct or indirect consideration for referring an insured to an automotive repair dealer or its employees or agents for vehicle repairs covered under a policyholder's automobile physical damage or automobile collision coverage, or to a contractor or its employees or agents for repairs to or replacement of a structure covered by a residential or commercial insurance policy.

(b) Except in cases in which the amount of the repair or replacement claim has been determined by the insurer and the repair or replacement services are performed in accordance with that determination or in accordance with provided estimates that are accepted by the insurer, it is unlawful for any automotive repair dealer, contractor, or employees or agents thereof to knowingly offer or give any discount intended to offset a deductible required by a policy of insurance covering repairs to or replacement of a motor vehicle or residential or commercial structure. This subdivision does not prohibit an advertisement for repair or replacement services at a discount as long as the amount of the repair or replacement claim has been determined by the insurer and the repair or replacement services are performed in accordance with that determination or in accordance with provided estimates that are accepted by the insurer.

(c) A violation of this section is a public offense. Where the amount at issue exceeds nine hundred fifty dollars (\$950), the offense is punishable by imprisonment pursuant to subdivision (h) of Section 1170 for 16 months, or two or three years, by a fine of not more than ten thousand dollars (\$10,000), or by both that imprisonment and fine; or by imprisonment in a county jail not to exceed one year, by a fine of not more than one thousand dollars (\$1,000), or by both that imprisonment and fine. In all other cases, the offense is punishable by imprisonment in a county jail not to exceed six months, by a fine of not more than one thousand dollars (\$1,000), or by both that imprisonment and fine.

(d) Every person who, having been convicted of subdivision (a) or (b), or Section 7027.3 or former Section 9884.75 of the Business and Professions Code and having served a term therefor in any penal institution or having been imprisoned therein as a condition of probation for that offense, is subsequently convicted of subdivision (a) or (b), upon a subsequent conviction of one of those offenses, shall be punished by imprisonment pursuant to subdivision (h) of Section 1170 for 16 months, or two or three years, by a fine of not more than ten thousand dollars (\$10,000), or by both that imprisonment and fine; or by imprisonment in a county jail not to exceed one year, by a fine of not more than one thousand dollars (\$1,000), or by both that imprisonment and fine.

(e) For purposes of this section:

(1) "Automotive repair dealer" means a person who, for compensation, engages in the business of repairing or diagnosing malfunctions of motor vehicles.

(2) “Contractor” has the same meaning as set forth in Section 7026 of the Business and Professions Code.

Added Stats 1992 ch 675 § 9 (AB 3067). Amended Stats 1993 ch 462 § 1 (AB 438), effective September 25, 1993; Stats 1995 ch 373 § 1 (SB 639);

Stats 2009–2010 3d Ex Sess ch 28 § 30 (SB 18XXX), effective January 25, 2010; Stats 2011 ch 15 § 393 (AB 109), effective April 4, 2011, operative October 1, 2011.

## PART 2 Of Criminal Procedure

### TITLE 11 Proceedings in Misdemeanor and Infraction Cases and Appeals from Such Cases

#### CHAPTER 1 Proceedings in Misdemeanor and Infraction Cases

Section

1463.15. Use of certain funds derived from fines imposed for unlawful motor vehicle exhaust discharge to pay for combined inspection and sobriety checkpoint program

**§ 1463.15. Use of certain funds derived from fines imposed for unlawful motor vehicle exhaust discharge to pay for combined inspection and sobriety checkpoint program**

Notwithstanding Section 1463, if a county board of supervisors establishes a combined vehicle inspection

and sobriety checkpoint program under Section 2814.1 of the Vehicle Code, thirty-five dollars (\$35) of the money deposited with the county treasurer under Section 1463.001 and collected from each fine and forfeiture imposed under subdivision (b) of Section 42001.2 of the Vehicle Code shall be deposited in a special account to be used exclusively to pay the cost incurred by the county for establishing and conducting the combined vehicle inspection and sobriety checkpoint program. The money allocated to pay the cost incurred by the county for establishing and conducting the combined checkpoint program pursuant to this section may only be deposited in the special account after a fine imposed pursuant to subdivision (b) of Section 42001.2, and any penalty assessment thereon, has been collected.

Added Stats 2003 ch 482 § 2 (SB 708).

# PUBLIC RESOURCES CODE

## DIVISION 30

### Waste Management

#### PART 3

#### State Programs

#### CHAPTER 17

#### California Tire Recycling Act

#### ARTICLE 5

#### Financial Provisions

##### Section

42885. (First of two; Repealed January 1, 2024) California tire fee; Tire Recycling Management Fund

42885. (Second of two; Operative January 1, 2024) California tire fee; Tire Recycling Management Fund

42889. (First of two; Repealed January 1, 2024) Expenditures from fund

42889. (Second of two; Operative January 1, 2024) Expenditures from fund

#### **§ 42885. (First of two; Repealed January 1, 2024) California tire fee; Tire Recycling Management Fund**

(a) For purposes of this section, “California tire fee” means the fee imposed pursuant to this section.

(b)(1) A person who purchases a new tire, as defined in subdivision (g), shall pay a California tire fee of one dollar and seventy-five cents (\$1.75) per tire.

(2) The retail seller shall charge the retail purchaser the amount of the California tire fee as a charge that is separate from, and not included in, any other fee, charge, or other amount paid by the retail purchaser.

(3) The retail seller shall collect the California tire fee from the retail purchaser at the time of sale and may retain 1½ percent of the fee as reimbursement for any costs associated with the collection of the fee. The retail seller shall remit the remainder to the state on a quarterly schedule for deposit in the California Tire Recycling Management Fund, which is hereby created in the State Treasury.

(c) The department, or its agent authorized pursuant to Section 42882, shall be reimbursed for its costs of collection, auditing, and making refunds associated with the California Tire Recycling Management Fund, but not to exceed 3 percent of the total annual revenue deposited in the fund.

(d) The California tire fee imposed pursuant to subdivision (b) shall be separately stated by the retail seller on the invoice given to the customer at the time of sale. Any other disposal or transaction fee charged by the retail seller related to the tire purchase shall be identified separately from the California tire fee.

(e) A person or business who knowingly, or with reckless disregard, makes a false statement or representa-

tion in a document used to comply with this section is liable for a civil penalty for each violation or, for continuing violations, for each day that the violation continues. Liability under this section may be imposed in a civil action and shall not exceed twenty-five thousand dollars (\$25,000) for each violation.

(f) In addition to the civil penalty that may be imposed pursuant to subdivision (e), the department may impose an administrative penalty in an amount not to exceed five thousand dollars (\$5,000) for each violation of a separate provision or, for continuing violations, for each day that the violation continues, on a person who intentionally or negligently violates a permit, rule, regulation, standard, or requirement issued or adopted pursuant to this chapter. The department shall adopt regulations that specify the amount of the administrative penalty and the procedure for imposing an administrative penalty pursuant to this subdivision.

(g) For purposes of this section, “new tire” means a pneumatic or solid tire intended for use with onroad or off-road motor vehicles, motorized equipment, construction equipment, or farm equipment that is sold separately from the motorized equipment, or a new tire sold with a new or used motor vehicle, as defined in Section 42803.5, including the spare tire, construction equipment, or farm equipment. “New tire” does not include retreaded, reused, or recycled tires.

(h) The California tire fee shall not be imposed on a tire sold with, or sold separately for use on, any of the following:

(1) A self-propelled wheelchair.

(2) A motorized tricycle or motorized quadricycle, as defined in Section 407 of the Vehicle Code.

(3) A vehicle that is similar to a motorized tricycle or motorized quadricycle and is designed to be operated by a person who, by reason of the person’s physical disability, is otherwise unable to move about as a pedestrian.

(i) This section shall remain in effect only until January 1, 2024, and as of that date is repealed, unless a later enacted statute, that is enacted before January 1, 2024, deletes or extends that date.

Added Stats 1990 ch 35 § 25 (SB 937), effective March 29, 1990. Amended Stats 1996 ch 304 § 1 (AB 2108); Stats 1998 ch 1020 § 2 (AB 117); Stats 2000 ch 838 § 16 (SB 876); Stats 2002 ch 625 § 15 (SB 649), effective September 17, 2002; Stats 2004 ch 707 § 13 (AB 923), repealed January 1, 2015; Stats 2006 ch 77 § 55 (AB 1803), effective July 18, 2006, repealed January 1, 2015; Stats 2013 ch 401 § 31 (AB 8), effective September 28, 2013, repealed January 1, 2024.

#### **§ 42885. (Second of two; Operative January 1, 2024) California tire fee; Tire Recycling Management Fund**

(a) For purposes of this section, “California tire fee” means the fee imposed pursuant to this section.

(b)(1) Every person who purchases a new tire, as defined in subdivision (g), shall pay a California tire fee of one dollar and seventy-five cents (\$1.75) per tire.



(2) The retail seller shall charge the retail purchaser the amount of the California tire fee as a charge that is separate from, and not included in, any other fee, charge, or other amount paid by the retail purchaser.

(3) The retail seller shall collect the California tire fee from the retail purchaser at the time of sale and may retain 3 percent of the fee as reimbursement for any costs associated with the collection of the fee. The retail seller shall remit the remainder to the state on a quarterly schedule for deposit in the California Tire Recycling Management Fund, which is hereby created in the State Treasury.

(c) The department, or its agent authorized pursuant to Section 42882, shall be reimbursed for its costs of collection, auditing, and making refunds associated with the California Tire Recycling Management Fund, but not to exceed 3 percent of the total annual revenue deposited in the fund.

(d) The California tire fee imposed pursuant to subdivision (b) shall be separately stated by the retail seller on the invoice given to the customer at the time of sale. Any other disposal or transaction fee charged by the retail seller related to the tire purchase shall be identified separately from the California tire fee.

(e) Any person or business who knowingly, or with reckless disregard, makes any false statement or representation in any document used to comply with this section is liable for a civil penalty for each violation or, for continuing violations, for each day that the violation continues. Liability under this section may be imposed in a civil action and shall not exceed twenty-five thousand dollars (\$25,000) for each violation.

(f) In addition to the civil penalty that may be imposed pursuant to subdivision (e), the department may impose an administrative penalty in an amount not to exceed five thousand dollars (\$5,000) for each violation of a separate provision or, for continuing violations, for each day that the violation continues, on any person who intentionally or negligently violates any permit, rule, regulation, standard, or requirement issued or adopted pursuant to this chapter. The department shall adopt regulations that specify the amount of the administrative penalty and the procedure for imposing an administrative penalty pursuant to this subdivision.

(g) For purposes of this section, “new tire” means a pneumatic or solid tire intended for use with onroad or off-road motor vehicles, motorized equipment, construction equipment, or farm equipment that is sold separately from the motorized equipment, or a new tire sold with a new or used motor vehicle, as defined in Section 42803.5, including the spare tire, construction equipment, or farm equipment. “New tire” does not include retreaded, reused, or recycled tires.

(h) The California tire fee may not be imposed on any tire sold with, or sold separately for use on, any of the following:

- (1) Any self-propelled wheelchair.
- (2) Any motorized tricycle or motorized quadricycle, as defined in Section 407 of the Vehicle Code.
- (3) Any vehicle that is similar to a motorized tricycle or motorized quadricycle and is designed to be operated by a person who, by reason of the person’s physical disability, is otherwise unable to move about as a pedestrian.

(i) This section shall become operative on January 1, 2024.

Added Stats 2004 ch 707 § 13.5 (AB 923), operative January 1, 2015. Amended Stats 2013 ch 401 § 32 (AB 8), effective September 28, 2013, operative January 1, 2024.

**§ 42889. (First of two; Repealed January 1, 2024) Expenditures from fund**

(a) Of the moneys collected pursuant to Section 42885, an amount equal to seventy-five cents (\$0.75) per tire on which the fee is imposed shall be transferred by the State Board of Equalization to the Air Pollution Control Fund. The state board shall expend those moneys, or allocate those moneys to the districts for expenditure, to fund programs and projects that mitigate or remediate air pollution caused by tires in the state, to the extent that the state board or the applicable district determines that the program or project remediates air pollution harms created by tires upon which the fee described in Section 42885 is imposed.

(b) The remaining moneys collected pursuant to Section 42885 shall be used to fund the waste tire program, and shall be appropriated to the department in the annual Budget Act in a manner consistent with the five-year plan adopted and updated by the department. These moneys shall be expended for the payment of refunds under this chapter and for the following purposes:

(1) To pay the administrative overhead cost of this chapter, not to exceed 6 percent of the total revenue deposited in the fund annually, or an amount otherwise specified in the annual Budget Act.

(2) To pay the costs of administration associated with collection, making refunds, and auditing revenues in the fund, not to exceed 3 percent of the total revenue deposited in the fund, as provided in subdivision (c) of Section 42885.

(3) To pay the costs associated with operating the tire recycling program specified in Article 3 (commencing with Section 42870).

(4) To pay the costs associated with the development and enforcement of regulations relating to the storage of waste tires and used tires. The department shall consider designating a city, county, or city and county as the enforcement authority of regulations relating to the storage of waste tires and used tires, as provided in subdivision (c) of Section 42850, and regulations relating to the hauling of waste and used tires, as provided in subdivision (b) of Section 42963. If the department designates a local entity for that purpose, the department shall provide sufficient, stable, and noncompetitive funding to that entity for that purpose, based on available resources, as provided in the five-year plan adopted and updated as provided in subdivision (a) of Section 42885.5. The department may consider and create, as appropriate, financial incentives for citizens who report the illegal hauling or disposal of waste tires as a means of enhancing local and statewide waste tire and used tire enforcement programs.

(5) To pay the costs of cleanup, abatement, removal, or other remedial action related to waste tire stockpiles throughout the state, including all approved costs incurred by other public agencies involved in these activities by contract with the department. Not less than six

million five hundred thousand dollars (\$6,500,000) shall be expended by the department during each of the following fiscal years for this purpose: 2001-02 to 2006-07, inclusive.

(6) To make studies and conduct research directed at promoting and developing alternatives to the landfill disposal of waste tires.

(7) To assist in developing markets and new technologies for used tires and waste tires. The department's expenditure of funds for purposes of this subdivision shall reflect the priorities for waste management practices specified in subdivision (a) of Section 40051.

(8) To pay the costs associated with implementing and operating a waste tire and used tire hauler program and manifest system pursuant to Chapter 19 (commencing with Section 42950).

(9) To pay the costs to create and maintain an emergency reserve, which shall not exceed one million dollars (\$1,000,000).

(10) To pay the costs of cleanup, abatement, or other remedial action related to the disposal of waste tires in implementing and operating the Farm and Ranch Solid Waste Cleanup and Abatement Grant Program established pursuant to Chapter 2.5 (commencing with Section 48100) of Part 7.

(11) To fund border region activities specified in paragraph (8) of subdivision (b) of Section 42885.5.

(c) This section shall remain in effect only until January 1, 2024, and as of that date is repealed, unless a later enacted statute that is enacted before January 1, 2024, deletes or extends that date.

Added Stats 1990 ch 35 § 25 (SB 937), effective March 29, 1990. Amended Stats 1993 ch 511 § 1 (SB 744); Stats 1997 ch 875 § 2 (SB 1330); Stats 2000 ch 838 § 18 (SB 876); Stats 2002 ch 625 § 18 (SB 649), effective September 17, 2002; Stats 2004 ch 707 § 14 (AB 923), repealed January 1, 2015; Stats 2006 ch 77 § 56 (AB 1803), effective July 18, 2006, repealed January 1, 2015; Stats 2008 ch 696 § 26 (SB 1781), effective September 30, 2008, repealed January 1, 2015; Stats 2009 ch 333 § 3 (SB 167), effective January 1, 2010, repealed January 1, 2015; Stats 2013 ch 401 § 33 (AB 8), effective September 28, 2013, repealed January 1, 2024.

**§ 42889. (Second of two; Operative January 1, 2024) Expenditures from fund**

Funding for the waste tire program shall be appropriated to the department in the annual Budget Act. The moneys in the fund shall be expended for the payment of refunds under this chapter and for the following purposes:

(a) To pay the administrative overhead cost of this chapter, not to exceed 5 percent of the total revenue deposited in the fund annually, or an amount otherwise specified in the annual Budget Act.

(b) To pay the costs of administration associated with collection, making refunds, and auditing revenues in the fund, not to exceed 3 percent of the total revenue deposited in the fund, as provided in subdivision (b) of Section 42885.

(c) To pay the costs associated with operating the tire recycling program specified in Article 3 (commencing with Section 42870).

(d) To pay the costs associated with the development and enforcement of regulations relating to the storage of waste tires and used tires. The department shall consider designating a city, county, or city and county as the enforcement authority of regulations relating to the storage of waste tires and used tires, as provided in subdivision (c) of Section 42850, and regulations relating to the hauling of waste and used tires, as provided in subdivision (b) of Section 42963. If the department designates a local entity for that purpose, the department shall provide sufficient, stable, and noncompetitive funding to that entity for that purpose, based on available resources, as provided in the five-year plan adopted and updated as provided in subdivision (a) of Section 42885.5. The department may consider and create, as appropriate, financial incentives for citizens who report the illegal hauling or disposal of waste tires as a means of enhancing local and statewide waste tire and used tire enforcement programs.

(e) To pay the costs of cleanup, abatement, removal, or other remedial action related to waste tire stockpiles throughout the state, including all approved costs incurred by other public agencies involved in these activities by contract with the department. Not less than six million five hundred thousand dollars (\$6,500,000) shall be expended by the department during each of the following fiscal years for this purpose: 2001-02 to 2006-07, inclusive.

(f) To fund border region activities specified in paragraph (8) of subdivision (b) of Section 42885.5.

(g) This section shall become operative on January 1, 2024.

Added Stats 2004 ch 707 § 14.5 (AB 923), operative January 1, 2015. Amended Stats 2008 ch 696 § 27 (SB 1781), effective September 30, 2008, operative January 1, 2015. Amended Stats 2009 ch 333 § 4 (SB 167), effective January 1, 2010, operative January 1, 2015; Stats 2013 ch 401 § 34 (AB 8), effective September 28, 2013, operative January 1, 2024.

# REVENUE AND TAXATION CODE

## DIVISION 2

### Other Taxes

#### PART 1

#### Sales and Use Taxes

#### CHAPTER 3.3

#### Vehicle Smog Impact Fee

Section  
6263. Emission control label

##### § 6263. Emission control label

No person, other than the manufacturer who has received authorization to sell the motor vehicle in California or a person authorized by the manufacturer, shall install a vehicle emission control label on any motor vehicle. No person shall remove, alter, deface, obscure, or destroy a vehicle emission control label or any label required to be affixed to any motor vehicle certified pursuant to the National Emissions Standards Act (42 U.S.C. Sec. 7521 et seq., and Subpart A (commencing with Sec. 86.078–3) of Part 86 of Title 40 of the Code of Federal Regulations). Any person who violates any provision of this section is guilty of a misdemeanor and is subject to a fine of not more than five thousand dollars (\$5,000) or imprisonment in the county jail for not more than one year, or both that fine and imprisonment.

Added Stats 1990 ch 1362 § 3 (AB 2561), effective September 25, 1990, operative October 15, 1990. Amended Stats 2000 ch 32 § 4 (SB 215), effective June 8, 2000.

#### CHAPTER 7

#### Overpayments and Refunds

#### ARTICLE 1

#### Claim for Refund

Section  
6909. Smog fee refunds

##### § 6909. Smog fee refunds

(a) The Controller shall transfer the amount of six hundred sixty-five million two hundred sixty-one thousand dollars (\$665,261,000) from the General Fund to the Smog Impact Fee Refund Account, which is hereby created in the Special Deposit Fund.

(b) Notwithstanding Section 13340 of the Government Code, the moneys in the Smog Impact Fee Refund Account in the Special Deposit Fund are hereby continuously appropriated, without regard to fiscal years, to the Department of Motor Vehicles for the purpose of making refunds to persons who paid the smog impact fee for-

merly required by Chapter 3.3 (commencing with Section 6261) upon registering a vehicle in California. Each refund shall also include the amount of any penalties incurred by the payer with respect to the fee, and shall also include interest as specified in Sections 1673.2 and 1673.4 of the Vehicle Code. In addition, the appropriate level of court costs, fees, and expenses in the settlement of the case of *Jordan v. Department of Motor Vehicles* (1999) 75 Cal.App.4th 449, shall be determined through binding arbitration, and all of those fees, costs, or expenses shall be paid with funds from the account.

(c) The amount of any refund made under Section 1673.2 or Section 1673.4 of the Vehicle Code that is returned to the Department of Motor Vehicles because the recipient's mailing address as shown by the records of the department is incorrect shall be retained in the Smog Impact Fee Refund Account in the Special Deposit Fund until either of the following occurs:

(1) The department is able to ascertain the correct address of the recipient, at which time the refund shall be mailed to that address.

(2) The date upon which those funds are transferred from the Smog Impact Fee Refund Account in the Special Deposit Fund back to the General Fund.

(d) Any unencumbered balance remaining in the account on or after June 30, 2004, shall revert to the General Fund.

(e) The Legislature hereby finds and declares that the amount appropriated under subdivision (b) is a refund of taxes, as described in subdivision (a) of Section 8 of Article XIII of the Constitution, and, as a result, is not included within the "appropriations subject to limitation" of the state, as defined in that subdivision (a).

Added Stats 2000 ch 32 § 5 (SB 215), effective June 8, 2000.

#### PART 10

#### Personal Income Tax

#### CHAPTER 3

#### Computation of Taxable Income

#### ARTICLE 3

#### Items Specifically Excluded from Gross Income

Section  
17139.5. Interest on smog fee refund

##### § 17139.5. Interest on smog fee refund

For taxpayers who were not allowed to deduct the vehicle smog impact fee imposed by Section 6262 when

paid or incurred, any interest paid by this state in conjunction with the refund of the smog impact fee shall be excluded from gross income.

Added Stats 2000 ch 31 § 2 (AB 809), effective June 8, 2000.

# VEHICLE CODE

## DIVISION 1

### Words and Phrases Defined

#### Section

- 108. "Airbrakes"
- 165. "Authorized emergency vehicle"
- 220. "Automobile dismantler"
- 221. Exclusions from term "automobile dismantler"; Requisite forms
- 234. "Business"
- 246. "Certificate of compliance"
- 259. "Collector motor vehicle"
- 260. "Commercial vehicle"
- 285. "Dealer"
- 286. Dealer; Exclusions
- 288. "Declared combined gross weight"
- 289. "Declared gross vehicle weight"
- 295.5. "Disabled person"
- 296. "Distributor"
- 340. "Garage"
- 350. "Gross vehicle weight rating"
- 370. "Legal owner"
- 372. "Lessor"
- 375. "Lighting equipment"
- 385.5. "Low-speed vehicle"
- 400. "Motorcycle"
- 410. "Motor truck" or "motortruck"
- 415. "Motor vehicle"
- 425. "Muffler"
- 426. "New motor vehicle dealer"
- 430. "New vehicle"
- 431. "Nonrepairable vehicle"
- 432. "Nonrepairable vehicle certificate"
- 460. "Owner"
- 465. "Passenger vehicle"
- 471. "Pickup truck"
- 480. "Power brake"
- 505. "Registered owner"
- 506. "Registration year"
- 510. "Repair shop"
- 521.5. "Revived salvage vehicle"
- 543.5. "Salvage vehicle rebuilder"
- 580. "Specially constructed vehicle"
- 593. "Supplemental restraint system"
- 615. "Tow truck"; "Repossessor's tow vehicle"; "Automobile dismantlers' tow vehicle"
- 665. "Used vehicle"
- 670. "Vehicle"
- 670.5. "Vehicle frame"
- 671. "Vehicle identification number"
- 672. "Vehicle manufacturer"

#### § 108. "Airbrakes"

"Airbrakes" means a brake system using compressed air either for actuating the service brakes at the wheels of the vehicle or as a source of power for controlling or applying service brakes which are actuated through hydraulic or other intermediate means.

Added Stats 1963 ch 207 § 1.

#### § 165. "Authorized emergency vehicle"

An authorized emergency vehicle is:

(a) Any publicly owned and operated ambulance, life-guard, or lifesaving equipment or any privately owned or operated ambulance licensed by the Commissioner of the California Highway Patrol to operate in response to emergency calls.

(b) Any publicly owned vehicle operated by the following persons, agencies, or organizations:

(1) Any federal, state, or local agency, department, or district employing peace officers as that term is defined in Chapter 4.5 (commencing with Section 830) of Part 2 of Title 3 of the Penal Code, for use by those officers in the performance of their duties.

(2) Any forestry or fire department of any public agency or fire department organized as provided in the Health and Safety Code.

(c) Any vehicle owned by the state, or any bridge and highway district, and equipped and used either for fighting fires, or towing or servicing other vehicles, caring for injured persons, or repairing damaged lighting or electrical equipment.

(d) Any state-owned vehicle used in responding to emergency fire, rescue, or communications calls and operated either by the Office of Emergency Services or by any public agency or industrial fire department to which the Office of Emergency Services has assigned the vehicle.

(e) Any vehicle owned or operated by any department or agency of the United States government when the vehicle is used in responding to emergency fire, ambulance, or lifesaving calls or is actively engaged in law enforcement work.

(f) Any vehicle for which an authorized emergency vehicle permit has been issued by the Commissioner of the California Highway Patrol.

Added Stats 1961 ch 653 § 12, operative January 1, 1962. Amended Stats 1967 ch 1009 § 2; Stats 1968 ch 1309 § 1, operative January 1, 1969; Stats 1971 ch 438 § 178; Stats 1972 ch 431 § 52; Stats 1973 ch 35 § 1; Stats 1974 ch 581 § 1; Stats 1977 ch 1017 § 1, effective September 23, 1977; Stats 1980 ch 1340 § 26.5, effective September 30, 1980; Stats 1981 ch 973 § 3; Stats 1982 ch 16 § 1; Stats 1983 ch 1292 § 8; Stats 2010 ch 618 § 291 (AB 2791), effective January 1, 2011; Stats 2013 ch 352 § 516 (AB 1317), effective September 26, 2013, operative July 1, 2013.

#### § 220. "Automobile dismantler"

An "automobile dismantler" is any person not otherwise expressly excluded by Section 221 who:

(a) Is engaged in the business of buying, selling, or dealing in vehicles of a type required to be registered under this code, including nonrepairable vehicles, for the purpose of dismantling the vehicles, who buys or sells the integral parts and component materials thereof, in whole or in part, or deals in used motor vehicle parts. This section does not apply to the occasional and incidental dismantling of vehicles by dealers who have secured dealers plates from the department for the current year whose principal business is buying and selling new and used vehicles, or by owners who desire to dismantle not more than three personal vehicles within any 12-month period.

(b) Notwithstanding the provisions of subdivision (a), keeps or maintains on real property owned by him, or

under his possession or control, two or more unregistered motor vehicles no longer intended for, or in condition for, legal use on the highways, whether for the purpose of resale of used parts, for the purpose of reclaiming for use some or all of the materials, whether metal, glass, fabric, or otherwise, or to dispose of them, or for any other purpose.

Enacted Stats 1959 ch 3. Amended Stats 1963 ch 1106 § 1; Stats 1967 ch 481 § 1; Stats 1971 ch 1043 § 1, ch 1624 § 1; Stats 1974 ch 613 § 1; Stats 1975 ch 1224 § 1; Stats 1976 ch 937 § 1; Stats 1994 ch 1008 § 5, operative July 1, 1995.

**§ 221. Exclusions from term “automobile dismantler”; Requisite forms**

(a) The term “automobile dismantler” does not include any of the following:

(1) The owner or operator of any premises on which two or more unregistered and inoperable vehicles are held or stored, if the vehicles are used for restoration or replacement parts or otherwise, in conjunction with any of the following:

(A) Any business of a licensed dealer, manufacturer, or transporter.

(B) The operation and maintenance of any fleet of motor vehicles used for the transportation of persons or property.

(C) Any agricultural, farming, mining, or ranching business that does not sell parts of the vehicles, except for either of the following purposes:

(i) For use in repairs performed by that business.

(ii) For use by a licensed dismantler or an entity described in paragraph (3).

(D) Any motor vehicle repair business registered with the Bureau of Automotive Repair, or those exempt from registration under the Business and Professions Code or applicable regulations, that does not sell parts of the vehicles, except for either of the following purposes:

(i) For use in repairs performed by that business.

(ii) For use by a licensed dismantler or an entity described in paragraph (3).

(2) Any person engaged in the restoration of vehicles of the type described in Section 5004 or in the restoration of other vehicles having historic or classic significance.

(3) The owner of a steel mill, scrap metal processing facility, or similar establishment purchasing vehicles of a type subject to registration, not for the purpose of selling the vehicles, in whole or in part, but exclusively for the purpose of reducing the vehicles to their component materials, if either the facility obtains, on a form approved or provided by the department, a certification by the person from whom the vehicles are obtained that each of the vehicles has been cleared for dismantling pursuant to Section 5500 or 11520, or the facility complies with Section 9564.

(4) Any person who acquires used parts or components for resale from vehicles which have been previously cleared for dismantling pursuant to Section 5500 or 11520.

Nothing in this paragraph permits a dismantler to acquire or sell used parts or components during the time the dismantler license is under suspension.

(b) Any vehicle acquired for the purpose specified in paragraph (3) of subdivision (a) from other than a licensed dismantler, or from other than an independent

hauler who obtained the vehicle, or parts thereof from a licensed dismantler, shall be accompanied by either a receipt issued by the department evidencing proof of clearance for dismantling under Section 5500, or a copy of the ordinance or order issued by a local authority for the abatement of the vehicle pursuant to Section 22660. The steel mill, scrap metal processing facility, or similar establishment acquiring the vehicle shall attach the form evidencing clearance or abatement to the certification required pursuant to this section.

All forms specified in paragraph (3) of subdivision (a) and in this subdivision shall be available for inspection by a peace officer during business hours.

Added Stats 1976 ch 937 § 2. Amended Stats 1979 ch 622 § 1; Stats 1981 ch 271 § 1; Stats 1985 ch 1022 § 1; Stats 1987 ch 709 § 1, ch 1133 § 2; Stats 1999 ch 316 § 1 (AB 342).

**§ 234. “Business”**

A “business” includes a proprietorship, partnership, corporation, and any other form of commercial enterprise.

Added Stats 1990 ch 1563 § 1 (AB 3243).

**§ 246. “Certificate of compliance”**

A “certificate of compliance” for the purposes of this code is an electronic or printed document issued by a state agency, board, or commission, or authorized person, setting forth that the requirements of a particular law, rule or regulation, within its jurisdiction to regulate or administer has been satisfied.

Added Stats 1963 ch 666 § 1. Amended Stats 1967 ch 478 § 1; Stats 1999 ch 1007 § 15 (SB 532).

**§ 259. “Collector motor vehicle”**

“Collector motor vehicle” means a motor vehicle owned by a collector, as defined in subdivision (a) of Section 5051, and the motor vehicle is used primarily in shows, parades, charitable functions, and historical exhibitions for display, maintenance, and preservation, and is not used primarily for transportation.

Added Stats 2004 ch 107 § 1 (SB 1784).

**§ 260. “Commercial vehicle”**

(a) A “commercial vehicle” is a motor vehicle of a type required to be registered under this code used or maintained for the transportation of persons for hire, compensation, or profit or designed, used, or maintained primarily for the transportation of property.

(b) Passenger vehicles and house cars that are not used for the transportation of persons for hire, compensation, or profit are not commercial vehicles. This subdivision shall not apply to Chapter 4 (commencing with Section 6700) of Division 3.

(c) Any vanpool vehicle is not a commercial vehicle.

(d) The definition of a commercial vehicle in this section does not apply to Chapter 7 (commencing with Section 15200) of Division 6.

Enacted Stats 1959 ch 3. Amended Stats 1963 ch 688 § 2; Stats 1982 ch 46 § 5; Stats 1988 ch 1509 § 1; Stats 2000 ch 861 § 11 (SB 2084), effective September 29, 2000. Amended Stats 2003 ch 222 § 1 (AB 1662).

**§ 285. “Dealer”**

“Dealer” is a person not otherwise expressly excluded by Section 286 who:

(a) For commission, money, or other thing of value, sells, exchanges, buys, or offers for sale, negotiates or attempts to negotiate, a sale or exchange of an interest in, a vehicle subject to registration, a motorcycle, snowmobile, or all-terrain vehicle subject to identification under this code, or a trailer subject to identification pursuant to Section 5014.1, or induces or attempts to induce any person to buy or exchange an interest in a vehicle and, who receives or expects to receive a commission, money, brokerage fees, profit, or any other thing of value, from either the seller or purchaser of the vehicle.

(b) Is engaged wholly or in part in the business of selling vehicles or buying or taking in trade, vehicles for the purpose of resale, selling, or offering for sale, or consigned to be sold, or otherwise dealing in vehicles, whether or not the vehicles are owned by the person.

Enacted Stats 1959 ch 3. Amended Stats 1959 ch 173 § 2, ch 1996 § 1.4; Stats 1961 ch 58 § 2, effective March 31, 1961; Stats 1979 ch 622 § 2; Stats 2001 ch 539 § 1 (SB 734). Amended Stats 2004 ch 836 § 1 (AB 2848); Stats 2005 ch 270 § 8 (SB 731), effective January 1, 2006.

### § 286. Dealer; Exclusions

The term “dealer” does not include any of the following:

(a) Insurance companies, banks, finance companies, public officials, or any other person coming into possession of vehicles in the regular course of business, who sells vehicles under a contractual right or obligation, in performance of an official duty, or in authority of any court of law, if the sale is for the purpose of saving the seller from loss or pursuant to the authority of a court.

(b) Persons who sell or distribute vehicles of a type subject to registration or trailers subject to identification pursuant to Section 5014.1 for a manufacturer to vehicle dealers licensed under this code, or who are employed by manufacturers or distributors to promote the sale of vehicles dealt in by those manufacturers or distributors. However, any of those persons who also sell vehicles at retail are vehicle dealers and are subject to this code.

(c) Persons regularly employed as salespersons by vehicle dealers licensed under this code while acting within the scope of that employment.

(d) Persons engaged exclusively in the bona fide business of exporting vehicles or of soliciting orders for the sale and delivery of vehicles outside the territorial limits of the United States, if no federal excise tax is legally payable or refundable on any of the transactions. Persons not engaged exclusively in the bona fide business of exporting vehicles, but who are engaged in the business of soliciting orders for the sale and delivery of vehicles, outside the territorial limits of the United States are exempt from licensure as dealers only if their sales of vehicles produce less than 10 percent of their total gross revenue from all business transacted.

(e) Persons not engaged in the purchase or sale of vehicles as a business, who dispose of any vehicle acquired and used in good faith, for their own personal use, or for use in their business, and not for the purpose of avoiding the provisions of this code.

(f) Persons who are engaged in the purchase, sale, or exchange of vehicles, other than motorcycles, all-terrain vehicles, or trailers subject to identification under this code, that are not intended for use on the highways.

(g) Persons temporarily retained as auctioneers solely for the purpose of disposing of vehicle stock inventories by means of public auction on behalf of the owners at the owners' place of business, or as otherwise approved by the department, if intermediate physical possession or control of, or an ownership interest in, the inventory is not conveyed to the persons so retained.

(h) Persons who are engaged exclusively in the business of purchasing, selling, servicing, or exchanging racing vehicles, parts for racing vehicles, and trailers designed and intended by the manufacturer to be used exclusively for carrying racing vehicles. For purposes of this subdivision, “racing vehicle” means a motor vehicle of a type used exclusively in a contest of speed or in a competitive trial of speed which is not intended for use on the highways.

(i) A person who is a lessor.

(j) A person who is a renter.

(k) A salvage pool.

(l) A yacht broker who is subject to the Yacht and Ship Brokers Act (Article 2 (commencing with Section 700) of Chapter 5 of Division 3 of the Harbors and Navigation Code) and who sells used boat trailers in conjunction with the sale of a vessel.

(m) A licensed automobile dismantler who sells vehicles that have been reported for dismantling as provided in Section 11520.

(n) The Director of Corrections when selling vehicles pursuant to Section 2813.5 of the Penal Code.

(o)(1) Any public or private nonprofit charitable, religious, or educational institution or organization that sells vehicles if all of the following conditions are met:

(A) The institution or organization qualifies for state tax-exempt status under Section 23701d of the Revenue and Taxation Code, and tax-exempt status under Section 501(c)(3) of the federal Internal Revenue Code.

(B) The vehicles sold were donated to the nonprofit charitable, religious, or educational institution or organization.

(C) The vehicles subject to retail sale meet all of the applicable equipment requirements of Division 12 (commencing with Section 24000) and are in compliance with emission control requirements as evidenced by the issuance of a certificate pursuant to subdivision (b) of Section 44015 of the Health and Safety Code. Under no circumstances may any institution or organization transfer the responsibility of obtaining a smog inspection certificate to the buyer of the vehicle.

(D) The proceeds of the sale of the vehicles are retained by that institution or organization for its charitable, religious, or educational purposes.

(2) An institution or organization described in paragraph (1) may sell vehicles on behalf of another institution or organization under the following conditions:

(A) The nonselling institution or organization meets the requirements of paragraph (1).

(B) The selling and nonselling institutions or organizations enter into a signed, written agreement pursuant to subparagraph (A) of paragraph (3) of subdivision (a) of Section 1660.

(C) The selling institution or organization transfers the proceeds from the sale of each vehicle to the nonselling institution or organization within 45 days of the sale. All net proceeds transferred to the nonselling insti-

tution or organization shall clearly be identifiable to the sale of a specific vehicle. The selling institution or organization may retain a percentage of the proceeds from the sale of a particular vehicle. However, any retained proceeds shall be used by the selling institution or organization for its charitable, religious, or educational purposes.

(D) At the time of transferring the proceeds, the selling institution or organization shall provide to the nonselling institution or organization, an itemized listing of the vehicles sold and the amount for which each vehicle was sold.

(E) In the event the selling institution or organization cannot complete a retail sale of a particular vehicle, or if the vehicle cannot be transferred as a wholesale transaction to a dealer licensed under this code, the vehicle shall be returned to the nonselling institution or organization and the written agreement revised to reflect that return. Under no circumstances may a selling institution or organization transfer or donate the vehicle to a third party that is excluded from the definition of a dealer under this section.

(3) An institution or organization described in this subdivision shall retain all records required to be retained pursuant to Section 1660.

(p) A motor club, as defined in Section 12142 of the Insurance Code, that does not arrange or negotiate individual motor vehicle purchase transactions on behalf of its members but refers members to a new motor vehicle dealer for the purchase of a new motor vehicle and does not receive a fee from the dealer contingent upon the sale of the vehicle.

Added Stats 1959 ch 1996 § 1.5. Amended Stats 1967 ch 394 § 1; Stats 1968 ch 505 § 1; Stats 1970 ch 1290 § 1, ch 1446 § 1; Stats 1974 ch 687 § 2; Stats 1976 ch 1284 § 3; Stats 1979 ch 622 § 3; Stats 1980 ch 629 § 1; Stats 1984 ch 1407 § 1; Stats 1988 ch 546 § 1; Stats 1989 ch 923 § 2; Stats 1991 ch 13 § 14 (AB 37), effective February 13, 1991, ch 928 § 13 (AB 1886), effective October 13, 1991; Stats 1992 ch 127 § 1 (AB 2273); Stats 1994 ch 1253 § 5 (AB 3539); Stats 2001 ch 460 § 1 (AB 871), ch 539 § 2.5 (SB 734); Stats 2002 ch 758 § 3 (AB 3024); Stats 2004 ch 836 § 2 (AB 2848).

**§ 288. “Declared combined gross weight”**

“Declared combined gross weight” equals the total unladen weight of the combination of vehicles plus the heaviest load that will be transported by that combination of vehicles.

Added Stats 2000 ch 861 § 12 (SB 2084), effective September 29, 2000.

**§ 289. “Declared gross vehicle weight”**

“Declared gross vehicle weight” means weight that equals the total unladen weight of the vehicle plus the heaviest load that will be transported on the vehicle.

Added Stats 2000 ch 861 § 13 (SB 2084), effective September 29, 2000.

**§ 295.5. “Disabled person”**

A “disabled person” is any of the following:

(a) Any person who has lost, or has lost the use of, one or more lower extremities or both hands, or who has significant limitation in the use of lower extremities, or who has a diagnosed disease or disorder which substantially impairs or interferes with mobility, or who is so severely disabled as to be unable to move without the aid of an assistant device.

(b) Any person who is blind to the extent that the person’s central visual acuity does not exceed 20/200 in the better eye, with corrective lenses, as measured by the Snellen test, or visual acuity that is greater than 20/200, but with a limitation in the field of vision such that the widest diameter of the visual field subtends an angle not greater than 20 degrees.

(c) Any person who suffers from lung disease to the extent of any of the following:

(1) The person’s forced (respiratory) expiratory volume for one second when measured by spirometry is less than one liter.

(2) The person’s arterial oxygen tension (pO<sub>2</sub>) is less than 60 mm/Hg on room air while the person is at rest.

(d) Any person who is impaired by cardiovascular disease to the extent that the person’s functional limitations are classified in severity as class III or class IV based upon standards accepted by the American Heart Association.

Added Stats 1989 ch 554 § 1.

**§ 296. “Distributor”**

A “distributor” is any person other than a manufacturer who sells or distributes new vehicles subject to registration under this code, new trailers subject to identification pursuant to Section 5014.1, or new off-highway motorcycles or all-terrain vehicles subject to identification under this code, to dealers in this state and maintains representatives for the purpose of contacting dealers or prospective dealers in this state.

Added Stats 1973 ch 996 § 3, operative July 1, 1974. Amended Stats 1975 ch 1224 § 2; Stats 1981 ch 338 § 1; Stats 1982 ch 1584 § 1; Stats 2001 ch 539 § 3 (SB 734); Stats 2004 ch 836 § 3 (AB 2848).

**§ 340. “Garage”**

A “garage” is a building or other place wherein the business of storing or safekeeping vehicles of a type required to be registered under this code and which belong to members of the general public is conducted for compensation.

Enacted Stats 1959 ch 3.

**§ 350. “Gross vehicle weight rating”**

(a) “Gross vehicle weight rating” (GVWR) means the weight specified by the manufacturer as the loaded weight of a single vehicle.

(b) Gross combination weight rating (GCWR) means the weight specified by the manufacturer as the loaded weight of a combination or articulated vehicle. In the absence of a weight specified by the manufacturer, GCWR shall be determined by adding the GVWR of the power unit and the total unladen weight of the towed units and any load thereon.

Added Stats 1959 ch 3, as Veh C § 390. Amended and renumbered by Stats 2000 ch 861 § 14.

**§ 370. “Legal owner”**

A “legal owner” is a person holding a security interest in a vehicle which is subject to the provisions of the Uniform Commercial Code, or the lessor of a vehicle to the State or to any county, city, district, or political subdivision of the State, or to the United States, under a lease, lease-sale, or rental-purchase agreement which



grants possession of the vehicle to the lessee for a period of 30 consecutive days or more.

Enacted Stats 1959 ch 3. Amended Stats 1963 ch 819 § 40, ch 1867 § 1.

### § 372. “Lessor”

A “lessor” is a person who, for a term exceeding four months, leases or offers for lease, negotiates or attempts to negotiate a lease, or induce any person to lease a motor vehicle; and who receives or expects to receive a commission, money, brokerage fees, profit or any other thing of value from the lessee of said vehicle. “Lessor” includes “bailor” and “lease” includes “bailment.”

Added Stats 1976 ch 1284 § 5.

### § 375. “Lighting equipment”

“Lighting equipment” is any of the following lamps or devices:

(a) A headlamp, auxiliary driving, passing, or fog lamp, fog taillamp, taillamp, stoplamp, supplemental stoplamp, license plate lamp, clearance lamp, side marker lamp, signal lamp or device, supplemental signal lamp, deceleration signal device, cornering lamp, running lamp, red, blue, amber, or white warning lamp, flashing red schoolbus lamp, side-mounted turn signal lamp, and schoolbus side lamp.

(b) An operating unit or canceling mechanism for turn signal lamps or for the simultaneous flashing of turn signal lamps as vehicular hazard signals, and an advance stoplamp switch.

(c) A flasher mechanism for turn signals, red schoolbus lamps, warning lamps, the simultaneous flashing of turn signal lamps as vehicular hazard signals, and the headlamp flashing systems for emergency vehicles.

(d) Any equipment regulating the light emitted from a lamp or device or the light sources therein.

(e) A reflector, including reflectors for use on bicycles, and reflectors used for required warning devices.

(f) An illuminating device that emits radiation predominantly in the infrared or ultraviolet regions of the spectrum, whether or not these emissions are visible to the unaided eye.

(g) An illuminated sign installed on a bus that utilizes an electronic display to convey the route designation, route number, run number, public service announcement, or any combination of this information, or an illuminated sign utilized pursuant to Section 25353.1.

Enacted Stats 1959 ch 3. Amended Stats 1961 ch 58 § 4, effective March 31, 1961, ch 159 § 1, ch 653 § 24, ch 1989 § 2; Stats 1963 ch 223 § 1; Stats 1965 ch 858 § 1, ch 1313 § 1.5; Stats 1967 ch 382 § 1; Stats 1970 ch 1477 § 1; Stats 1974 ch 584 § 1; Stats 1977 ch 800 § 1, effective September 14, 1977; Stats 1979 ch 723 § 1; Stats 1980 ch 399 § 1, effective July 11, 1980; Stats 1991 ch 13 § 15 (AB 37), effective February 13, 1991. Amended Stats 2004 ch 198 § 1 (SB 1236); Stats 2006 ch 881 § 1 (SB 1726), effective January 1, 2007; Stats 2011 ch 529 § 2 (AB 607), effective January 1, 2012.

### § 385.5. “Low-speed vehicle”

(a) A “low-speed vehicle” is a motor vehicle that meets all of the following requirements:

- (1) Has four wheels.
- (2) Can attain a speed, in one mile, of more than 20 miles per hour and not more than 25 miles per hour, on a paved level surface.
- (3) Has a gross vehicle weight rating of less than 3,000 pounds.

(b)(1) For the purposes of this section, a “low-speed vehicle” is not a golf cart, except when operated pursuant to Section 21115 or 21115.1.

(2) A “low-speed vehicle” is also known as a “neighborhood electric vehicle.”

Added Stats 1999 ch 140 § 1 (SB 186). Amended Stats 2004 ch 422 § 2 (AB 2353); Stats 2006 ch 66 § 1 (SB 1559), effective July 12, 2006.

### § 400. “Motorcycle”

(a) A “motorcycle” is a motor vehicle having a seat or saddle for the use of the rider, designed to travel on not more than three wheels in contact with the ground.

(b) A motor vehicle that has four wheels in contact with the ground, two of which are a functional part of a sidecar, is a motorcycle if the vehicle otherwise comes within the definition of subdivision (a).

(c) A farm tractor is not a motorcycle.

(d) A three-wheeled motor vehicle that otherwise meets the requirements of subdivision (a), has a partially or completely enclosed seating area for the driver and passenger, is used by local public agencies for the enforcement of parking control provisions, and is operated at slow speeds on public streets, is not a motorcycle. However, a motor vehicle described in this subdivision shall comply with the applicable sections of this code imposing equipment installation requirements on motorcycles.

Added Stats 1996 ch 453 § 4 (AB 153). Amended Stats 2008 ch 672 § 1 (AB 2272), effective January 1, 2009.

### § 410. “Motor truck” or “motortruck”

A “motor truck” or “motortruck” is a motor vehicle designed, used, or maintained primarily for the transportation of property.

Enacted Stats 1959 ch 3. Amended Stats 1993 ch 272 § 11 (AB 301), effective July 30, 1993.

### § 415. “Motor vehicle”

(a) A “motor vehicle” is a vehicle that is self-propelled.

(b) “Motor vehicle” does not include a self-propelled wheelchair, motorized tricycle, or motorized quadricycle, if operated by a person who, by reason of physical disability, is otherwise unable to move about as a pedestrian.

(c) For purposes of Chapter 6 (commencing with Section 3000) of Division 2, “motor vehicle” includes a recreational vehicle as that term is defined in subdivision (a) of Section 18010 of the Health and Safety Code, but does not include a truck camper.

Enacted Stats 1959 ch 3. Amended Stats 1990 ch 400 § 1 (AB 2953), effective July 20, 1990; Stats 1996 ch 124 § 112 (AB 3470); Stats 2003 ch 703 § 1 (SB 248); Stats 2004 ch 404 § 1 (SB 1725).

### § 425. “Muffler”

A “muffler” is a device consisting of a series of chambers or baffle plates, or other mechanical design, for the purpose of receiving exhaust gas from an internal combustion engine, and effective in reducing noise.

Enacted Stats 1959 ch 3.

### § 426. “New motor vehicle dealer”

“New motor vehicle dealer” is a dealer, as defined in Section 285, who, in addition to the requirements of that section, either acquires for resale new and unregistered

motor vehicles from manufacturers or distributors of those motor vehicles or acquires for resale new off-highway motorcycles, or all-terrain vehicles from manufacturers or distributors of the vehicles. A distinction shall not be made, nor any different construction be given to the definition of “new motor vehicle dealer” and “dealer” except for the application of the provisions of Chapter 6 (commencing with Section 3000) of Division 2 and Section 11704.5. Sections 3001 and 3003 do not, however, apply to a dealer who deals exclusively in motorcycles, all-terrain vehicles, or recreational vehicles, as defined in subdivision (a) of Section 18010 of the Health and Safety Code.

Added Stats 1967 ch 1397 § 1. Amended Stats 1973 ch 78 § 14; Stats 1975 ch 943 § 1; Stats 1982 ch 1584 § 4; Stats 1996 ch 1008 § 2 (AB 2367); Stats 2000 ch 135 § 153 (AB 2539); Stats 2003 ch 703 § 2 (SB 248); Stats 2004 ch 836 § 6 (AB 2848).

#### § 430. “New vehicle”

A “new vehicle” is a vehicle constructed entirely from new parts that has never been the subject of a retail sale, or registered with the department, or registered with the appropriate agency or authority of any other state, District of Columbia, territory or possession of the United States, or foreign state, province, or country.

Enacted Stats 1959 ch 3. Amended Stats 1965 ch 820 § 1; Stats 1983 ch 1286 § 9; Stats 1988 ch 1583 § 1; Stats 1994 ch 1253 § 6 (AB 3539).

#### § 431. “Nonrepairable vehicle”

A “nonrepairable vehicle” is a vehicle of a type otherwise subject to registration that meets the criteria specified in subdivision (a), (b), or (c). The vehicle shall be issued a nonrepairable vehicle certificate and the vehicle, the vehicle frame, or unitized frame and body, as applicable, and as defined in Section 670.5, shall not be titled or registered.

(a) A nonrepairable vehicle is a vehicle that has no resale value except as a source of parts or scrap metal, and which the owner irreversibly designates solely as a source of parts or scrap metal.

(b) A nonrepairable vehicle is a completely stripped vehicle (a surgical strip) recovered from theft, missing all of the bolt on sheet metal body panels, all of the doors and hatches, substantially all of the interior components, and substantially all of the grill and light assemblies, or that the owner designates has little or no resale value other than its worth as a source of scrap metal, or as a source of a vehicle identification number that could be used illegally.

(c) A nonrepairable vehicle is a completely burned vehicle (burned hulk) that has been burned to the extent that there are no more usable or repairable body or interior components, tires and wheels, or drive train components, and which the owner irreversibly designates as having little or no resale value other than its worth as scrap metal or as a source of a vehicle identification number that could be used illegally.

Added Stats 1994 ch 1008 § 6 (SB 1833), operative July 1, 1995. Amended Stats 2002 ch 670 § 1 (SB 1331).

#### § 432. “Nonrepairable vehicle certificate”

A “nonrepairable vehicle certificate” is a vehicle ownership document issued to the owner of a nonrepairable vehicle. Ownership of the vehicle may only be trans-

ferred two times on a nonrepairable vehicle certificate. A vehicle for which a nonrepairable vehicle certificate has been issued may not be titled or registered for use on the roads or highways of California. A nonrepairable vehicle certificate shall be conspicuously labeled with the word “nonrepairable” across the front.

Added Stats 1994 ch 1008 § 6.5 (SB 1833), operative July 1, 1995.

#### § 460. “Owner”

An “owner” is a person having all the incidents of ownership, including the legal title of a vehicle whether or not such person lends, rents, or creates a security interest in the vehicle; the person entitled to the possession of a vehicle as the purchaser under a security agreement; or the State, or any county, city, district, or political subdivision of the State, or the United States, when entitled to the possession and use of a vehicle under a lease, lease-sale, or rental-purchase agreement for a period of 30 consecutive days or more.

Enacted Stats 1959 ch 3. Amended Stats 1963 ch 819 § 41, ch 1867 § 2.

#### § 465. “Passenger vehicle”

A “passenger vehicle” is any motor vehicle, other than a motortruck, truck tractor, or a bus, as defined in Section 233, and used or maintained for the transportation of persons. The term “passenger vehicle” shall include a housecar.

Enacted Stats 1959 ch 3. Amended Stats 1961 ch 263 § 2; Stats 1963 ch 688 § 4; Stats 1969 ch 479 § 2; Stats 1976 ch 844 § 2; Stats 1982 ch 46 § 6; Stats 1999 ch 1008 § 1 (SB 533).

#### § 471. “Pickup truck”

A “pickup truck” is a motor truck with a manufacturer’s gross vehicle weight rating of less than 11,500 pounds, an unladen weight of less than 8,001 pounds, and which is equipped with an open box-type bed not exceeding 9 feet in length. “Pickup truck” does not include a motor vehicle otherwise meeting the above definition, that is equipped with a bed-mounted storage compartment unit commonly called a “utility body.”

Added Stats 1991 ch 13 § 16 (AB 37), effective February 13, 1991. Amended Stats 1991 ch 928 § 15 (AB 1886), effective October 13, 1991; Stats 1997 ch 652 § 8 (AB 1518).

#### § 480. “Power brake”

A “power brake” is any braking gear or mechanism that aids in applying the brakes of a vehicle and which utilizes vacuum, compressed air, electricity, or hydraulic pressure developed by the motive power of that vehicle for that purpose.

Enacted Stats 1959 ch 3. Amended Stats 1977 ch 102 § 1, effective June 15, 1977.

#### § 505. “Registered owner”

A “registered owner” is a person registered by the department as the owner of a vehicle.

Enacted Stats 1959 ch 3.

#### § 506. “Registration year”

“Registration year” is the period of time beginning with the date the vehicle is first required to be registered in this state and ending on the date designated by the director for expiration of the registration or the period of time designated for subsequent renewal thereof.

Added Stats 1973 ch 889 § 21, effective September 26, 1973.

**§ 510. “Repair shop”**

A “repair shop” is a place where vehicles subject to registration under this code are repaired, rebuilt, reconditioned, repainted, or in any way maintained for the public at a charge.

Enacted Stats 1959 ch 3.

**§ 521.5. “Revived salvage vehicle”**

“Revived salvage vehicle” means a total loss salvage vehicle as defined in Section 544, or a vehicle reported for dismantling pursuant to Section 5500 or 11520, that has been rebuilt or restored to legal operating condition with new or used component parts.

Added Stats 2002 ch 670 § 2 (SB 1331).

**§ 543.5. “Salvage vehicle rebuilder”**

“Salvage vehicle rebuilder” means any person who rebuilds a total loss salvage vehicle, as defined in Section 544, or a vehicle reported for dismantling pursuant to Section 11520, for subsequent resale. A person who, for personal use, rebuilds a total loss salvage vehicle, or a vehicle reported for dismantling, and registers that vehicle in his or her name, is not a salvage vehicle rebuilder. Nothing in this section exempts a salvage vehicle rebuilder from any applicable licensing requirements under this code.

Added Stats 2002 ch 670 § 3 (SB 1331).

**§ 580. “Specially constructed vehicle”**

A “specially constructed vehicle” is a vehicle which is built for private use, not for resale, and is not constructed by a licensed manufacturer or remanufacturer. A specially constructed vehicle may be built from (1) a kit; (2) new or used, or a combination of new and used, parts; or (3) a vehicle reported for dismantling, as required by Section 5500 or 11520, which, when reconstructed, does not resemble the original make of the vehicle dismantled. A specially constructed vehicle is not a vehicle which has been repaired or restored to its original design by replacing parts.

Enacted Stats 1959 ch 3. Amended Stats 1983 ch 1286 § 13.

**§ 593. “Supplemental restraint system”**

“Supplemental restraint system” means an automatic passive restraint system consisting of a bag that is designed to inflate upon collision, commonly referred to as an “airbag.”

Added Stats 2002 ch 670 § 4 (SB 1331).

**§ 615. “Tow truck”; “Repossessor’s tow vehicle”; “Automobile dismantlers’ tow vehicle”**

(a) A “tow truck” is a motor vehicle which has been altered or designed and equipped for, and primarily used in the business of, transporting vehicles by means of a crane, hoist, tow bar, tow line, or dolly or is otherwise primarily used to render assistance to other vehicles. A “roll-back carrier” designed to carry up to two vehicles is also a tow truck. A trailer for hire that is being used to transport a vehicle is a tow truck. “Tow truck” does not include an automobile dismantlers’ tow vehicle or a reposessor’s tow vehicle.

(b) “Repossessor’s tow vehicle” means a tow vehicle which is registered to a reposessor licensed or regis-

tered pursuant to Chapter 11 (commencing with Section 7500) of Division 3 of the Business and Professions Code that is used exclusively in the course of the repossession business.

(c) “Automobile dismantlers’ tow vehicle” means a tow vehicle which is registered by an automobile dismantler licensed pursuant to Chapter 3 (commencing with Section 11500) of Division 5 and which is used exclusively to tow vehicles owned by that automobile dismantler in the course of the automobile dismantling business.

Enacted Stats 1959 ch 3. Amended Stats 1982 ch 1273 § 1; Stats 1985 ch 710 § 1; Stats 1988 ch 924 § 1; Stats 1993 ch 479 § 2 (AB 1113); Stats 1999 ch 456 § 14 (SB 378).

**§ 665. “Used vehicle”**

A “used vehicle” is a vehicle that has been sold, or has been registered with the department, or has been sold and operated upon the highways, or has been registered with the appropriate agency of authority, of any other state, District of Columbia, territory or possession of the United States or foreign state, province or country, or unregistered vehicles regularly used or operated as demonstrators in the sales work of a dealer or unregistered vehicles regularly used or operated by a manufacturer in the sales or distribution work of such manufacturer. The word “sold” does not include or extend to: (1) any sale made by a manufacturer or a distributor to a dealer, (2) any sale by a new motor vehicle dealer franchised to sell a particular line—make to another new motor vehicle dealer franchised to sell the same line—make, or (3) any sale by a dealer to another dealer licensed under this code involving a mobilehome, as defined in Section 396, a recreational vehicle, as defined in Section 18010.5 of the Health and Safety Code, a commercial coach, as defined in Section 18012 of the Health and Safety Code, an off-highway motor vehicle subject to identification, as defined in Section 38012, or a commercial vehicle, as defined in Section 260.

Enacted Stats 1959 ch 3. Amended Stats 1965 ch 820 § 2; Stats 1967 ch 801 § 1; Stats 1988 ch 1583 § 2.

**§ 670. “Vehicle”**

A “vehicle” is a device by which any person or property may be propelled, moved, or drawn upon a highway, excepting a device moved exclusively by human power or used exclusively upon stationary rails or tracks.

Enacted Stats 1959 ch 3. Amended Stats 1975 ch 987 § 3.

**§ 670.5. “Vehicle frame”**

A “vehicle frame” is defined as the main longitudinal structural members of the chassis of the vehicle, or for vehicles with unitized body construction, the lowest main longitudinal structural members of the body of the vehicle, used as the major support in the construction of the motor vehicle.

Added Stats 2002 ch 670 § 5 (SB 1331).

**§ 671. “Vehicle identification number”**

(a) A “vehicle identification number” is the motor number, serial number, or other distinguishing number, letter, mark, character, or datum, or any combination thereof, required or employed by the manufacturer or the department for the purpose of uniquely identifying a

motor vehicle or motor vehicle part or for the purpose of registration.

(b) Whenever a vehicle is constructed of component parts identified with one or more different vehicle identification numbers, the vehicle identification number stamped or affixed by the manufacturer or authorized governmental entity on the frame or unitized frame and body, as applicable, and as defined in Section 670.5, shall determine the identity of the vehicle for registration purposes.

Added Stats 1993 ch 386 § 2 (SB 73), effective September 7, 1993. Amended Stats 2002 ch 670 § 6 (SB 1331).

**§ 672. “Vehicle manufacturer”**

(a) “Vehicle manufacturer” is any person who produces from raw materials or new basic components a vehicle of a type subject to registration under this code, off-highway motorcycles or all-terrain vehicles subject to identification under this code, or trailers subject to identification pursuant to Section 5014.1, or who permanently alters, for purposes of retail sales, new commercial vehicles by converting the vehicles into house cars

that display the insignia of approval required by Section 18056 of the Health and Safety Code and any regulations issued pursuant thereto by the Department of Housing and Community Development. As used in this section, “permanently alters” does not include the permanent attachment of a camper to a vehicle.

(b) A vehicle manufacturer that produces a vehicle of a type subject to registration that consists of used or reconditioned parts, for the purposes of the code, is a remanufacturer, as defined in Section 507.8.

(c) Unless a vehicle manufacturer either grants franchises to franchisees in this state, or issues vehicle warranties directly to franchisees in this state or consumers in this state, the manufacturer shall have an established place of business or a representative in this state.

(d) The scope and application of this section are limited to Division 2 (commencing with Section 1500) and Division 5 (commencing with Section 11100).

Added Stats 1977 ch 873 § 2. Amended Stats 1982 ch 1584 § 6; Stats 1983 ch 1286 § 14; Stats 1996 ch 124 § 113 (AB 3470); Stats 2001 ch 539 § 8 (SB 734); Stats 2002 ch 664 § 213 (AB 3034); Stats 2004 ch 836 § 7 (AB 2848).

**DIVISION 2**

**Administration**

**CHAPTER 1**

**The Department of Motor Vehicles**

**ARTICLE 2**

**Powers and Duties**

Section

- 1673. “Registered owner or lessee”
- 1673.2. Smog fee refund
- 1673.4. Claims for smog fee refunds
- 1673.5. Erroneous payment of smog refund
- 1673.6. False refund claims
- 1673.7. Notice to accompany refund

**§ 1673. “Registered owner or lessee”**

For the purposes of refunding the smog impact fee, as prescribed in Sections 1673.2 and 1673.4, “registered owner or lessee” means the person or persons to whom the registration or title was issued when the transaction that included the imposition of the smog impact fee under Chapter 3.3 (commencing with Section 6261) of Part 1 of Division 2 of the Revenue and Taxation Code was completed.

Added Stats 2000 ch 31 § 3 (AB 809), effective June 8, 2000.

**§ 1673.2. Smog fee refund**

(a) The department, in coordination with the Department of Finance, shall do all of the following:

(1) Search its records to identify the registered owner or lessee. Except as required under Section 1673.4, the department shall mail to the registered owner or lessee a refund notification form notifying the registered owner or lessee that he or she is eligible for a refund of the smog impact fee. This form shall identify the vehicle make and year, and include a refund claim that shall be signed,

under penalty of perjury, and returned to the department.

(2) Shall acknowledge by mail claims for refund from registered owners or lessees received prior to the effective date of this section.

(3) Except as provided in Section 1673.4, shall verify whether the information provided in any claim is true and correct and shall refund the three hundred dollar (\$300) smog impact fee, plus the amount of any penalty collected for late payment of the smog impact fee, and any interest earned on those charges, to the person shown to be the registered owner or lessee.

(b) Notwithstanding any other provision of law, interest shall be paid on all claims at a single annual rate, calculated by the Department of Finance, that averages the annualized interest rates earned by the Pooled Money Investment Account for the period beginning October 1990 and ending on the effective date of this section. Interest on each refund shall be calculated from the date the smog impact fee and vehicle registration transaction was completed to the date the refund is issued. Accrual of interest shall terminate one year after the effective date of this section.

(c)(1) Notwithstanding any other provision of law, those who paid the smog impact fee between October 15, 1990, and October 19, 1999, may file a claim for refund.

(2) Claims for refund by a registered owner or lessee shall be filed with the Department of Motor Vehicles within three years of the effective date of this section.

Added Stats 2000 ch 31 § 4 (AB 809), effective June 8, 2000. Amended Stats 2010 ch 719 § 64 (SB 856), effective October 19, 2010.

**§ 1673.4. Claims for smog fee refunds**

(a) Any claim submitted by a person other than a registered owner or lessee shall be filed within 30 days from the effective date of this section.

(b) If a claimant other than the registered owner or lessee files a claim, or has filed a claim prior to the effective date of this section, for refund in a manner and form verified by the department, the department shall mail a notification to the registered owner or lessee informing that person that he or she is eligible for a refund of the smog impact fee and that a competing claim for that fee has been filed. The registered owner or lessee shall have three years from the effective date of this section to inform the department that the registered owner or lessee opposes payment of the smog impact fee refund to the competing claimant. In that case, the refund shall be made to the registered owner or lessee and notice of that action shall be sent to the competing claimant. If the registered owner or lessee does not notify the department within the three-year period that he or she opposes the payment, the department shall pay the refund to the competing claimant.

(c) If any refund paid by the department under this section is disputed, any party that filed a claim may commence an action in small claims court. The small claims court action may not be filed if three years or more have elapsed from the date the department mailed the refund to either party.

(d) The State of California, its departments and agencies, and their officers or employees shall not be a party to a lawsuit between competing claimants relating to smog impact fee refunds.

Added Stats 2000 ch 31 § 5 (AB 809), effective June 8, 2000.

#### § 1673.5. Erroneous payment of smog refund

The department shall attempt to recover any refund of the smog impact fee, or part thereof, that is erroneously made. Collection shall be initiated if the recipient fails to respond to the Department of Motor Vehicles' notice to pay the erroneous refund within 90 days in accordance with existing collection procedures utilized by the department.

Added Stats 2000 ch 31 § 6 (AB 809), effective June 8, 2000.

#### § 1673.6. False refund claims

It is unlawful to use a false or fictitious name, to knowingly make any false statement, or conceal any material fact on a refund claim for the smog impact fee that is filed with the department. A violation of this provision is punishable under Section 72 of the Penal Code. Any signed claim form submitted to the department for a refund of the smog impact fee shall be signed under penalty of perjury.

Added Stats 2000 Ch 31 § 7 (AB 809), effective June 8, 2000.

#### § 1673.7. Notice to accompany refund

(a) The department shall include the following notice with each check issued as a refund of the smog impact fee:

"The enclosed check is a refund of the \$300 Smog Impact Fee you paid to the Department of Motor Vehicles when you initially registered an out-of-state vehicle in California. In the case of *Jordan v. Department of Motor Vehicles* (1999) 75 Cal.App.4th 449, the court ruled the smog impact fee unconstitutional. The enclosed check includes an interest payment which has been calculated

from the date the fee was paid to the date the refund is issued.

"If you have any questions about the enclosed refund, please contact your local office of the Department of Motor Vehicles."

(b) No notice other than the one required under subdivision (a) may be included with a smog impact fee refund check.

Added Stats 2000 ch 31 § 8 (AB 809), effective June 8, 2000.

## CHAPTER 4

### Administration and Enforcement

#### ARTICLE 1

#### Lawful Orders and Inspections

##### Section

2814. Combined vehicle inspection and sobriety checkpoint; Funding  
2814.1. Vehicle inspection checkpoint program; Motorcycle only checkpoints

#### § 2814. Combined vehicle inspection and sobriety checkpoint; Funding

Every driver of a passenger vehicle shall stop and submit the vehicle to an inspection of the mechanical condition and equipment of the vehicle at any location where members of the California Highway Patrol are conducting tests and inspections of passenger vehicles and when signs are displayed requiring such stop.

The Commissioner of the California Highway Patrol may make and enforce regulations with respect to the issuance of stickers or other devices to be displayed upon passenger vehicles as evidence that the vehicles have been inspected and have been found to be in safe mechanical condition and equipped as required by this code and equipped with certified motor vehicle pollution control devices as required by Part 5 (commencing with Section 43000) of Division 26 of the Health and Safety Code which are correctly installed and in operating condition. Any sticker so issued shall be placed on the windshield within a seven-inch square as provided in Section 26708.

If, upon such inspection of a passenger vehicle, it is found to be in unsafe mechanical condition or not equipped as required by this code and the provisions of Part 5 (commencing with Section 43000) of Division 26 of the Health and Safety Code, the provisions of Article 2 (commencing with Section 40150) of Chapter 1 of Division 17 of this code shall apply.

The provisions of this section relating to motor vehicle pollution control devices apply to vehicles of the United States or its agencies, to the extent authorized by federal law.

Added Stats 1965 ch 2031 § 10. Amended Stats 1968 ch 49 § 6, effective April 25, 1968, ch 178 § 1, ch 764 § 10; Stats 1971 ch 739 § 4; Stats 1975 ch 957 § 20.

#### § 2814.1. Vehicle inspection checkpoint program; Motorcycle only checkpoints

(a) A board of supervisors of a county may, by ordinance, establish, on highways under its jurisdiction, a vehicle inspection checkpoint program to check for vio-

lations of Sections 27153 and 27153.5. The program shall be conducted by the local agency or department with the primary responsibility for traffic law enforcement.

(b) A driver of a motor vehicle shall stop and submit to an inspection conducted under subdivision (a) when signs and displays are posted requiring that stop.

(c) A county that elects to conduct the program described under subdivision (a) may fund that program through fine proceeds deposited with the county under Section 1463.15 of the Penal Code.

(d) State and local law enforcement agencies shall not conduct motorcycle only checkpoints.

Added Stats 2003 ch 482 § 3 (SB 708). Amended Stats 2011 ch 653 § 1 (AB 353), effective January 1, 2012; Stats 2012 ch 89 § 2 (AB 1047), effective January 1, 2013.

**CHAPTER 6**

**New Motor Vehicle Board**

**ARTICLE 1**

**Organization of Board**

Section  
3016. Funding through imposition of fees

**§ 3016. Funding through imposition of fees**

(a) New motor vehicle dealers and other licensees under the jurisdiction of the board shall be charged fees sufficient to fully fund the activities of the board other than those conducted pursuant to Section 472.5 of the Business and Professions Code. The board may recover the direct cost of the activities required by Section 472.5 of the Business and Professions Code by charging the Department of Consumer Affairs a fee which shall be paid by the Department of Consumer Affairs with funds appropriated from the Certification Account in the Consumer Affairs Fund. All fees shall be deposited, and held separate from other moneys, in the Motor Vehicle Account in the State Transportation Fund, and shall not be transferred to the State Highway Account pursuant to Section 42273.

(b) The fees shall be available, when appropriated, exclusively to fund the activities of the board. If, at the conclusion of any fiscal year, the amount of fees collected exceeds the amount of expenditures for this purpose during the fiscal year, the surplus shall be carried over into the succeeding fiscal year.

Added Stats 1982 ch 327 § 197, effective June 30, 1982. Amended Stats 1983 ch 1144 § 3.2, effective September 28, 1983; Stats 1985 ch 1201 § 1, effective September 29, 1985; Stats 1989 ch 193 § 3; Stats 1990 ch 216 § 113 (SB 2510); Stats 1996 ch 1088 § 13 (AB 2515), effective September 30, 1996; Stats 1997 ch 17 § 143 (SB 947).

**DIVISION 3**

**Registration of Vehicles and Certificates of Title**

**CHAPTER 1**

**Original and Renewal of  
Registration; Issuance of Certificates  
of Title**

**ARTICLE 1**

**Vehicles Subject to Registration**

Section  
4000. Registration required; Exceptions  
4000.1. Pollution control device; Certificate or statement  
4000.2. Pollution control compliance certificate for vehicles previously registered outside state  
4000.3. Biennial certificate of compliance required  
4000.4. Mandatory registration of vehicles in California  
4000.6. Registration of commercial vehicle over 10,000 pounds  
4001. Registration of vehicles exempt from fees  
4002. Vehicles exempt under permit  
4003. One-trip permit  
4003.5. One-trip permit for specified vehicles

**§ 4000. Registration required; Exceptions**

(a)(1) A person shall not drive, move, or leave standing upon a highway, or in an offstreet public parking facility, any motor vehicle, trailer, semitrailer, pole or pipe dolly, or logging dolly, unless it is registered and the appropriate fees have been paid under this code or registered under the permanent trailer identification program, except that an off-highway motor vehicle which displays an identification plate or device issued by the department pursuant to Section 38010 may be driven,

moved, or left standing in an offstreet public parking facility without being registered or paying registration fees.

(2) For purposes of this subdivision, "offstreet public parking facility" means either of the following:

(A) Any publicly owned parking facility.

(B) Any privately owned parking facility for which no fee for the privilege to park is charged and which is held open for the common public use of retail customers.

(3) This subdivision does not apply to any motor vehicle stored in a privately owned offstreet parking facility by, or with the express permission of, the owner of the privately owned offstreet parking facility.

(4) Beginning July 1, 2011, the enforcement of paragraph (1) shall commence on the first day of the second month following the month of expiration of the vehicle's registration. This paragraph shall become inoperative on January 1, 2012.

(b) No person shall drive, move, or leave standing upon a highway any motor vehicle, as defined in Chapter 2 (commencing with Section 39010) of Part 1 of Division 26 of the Health and Safety Code, which has been registered in violation of Part 5 (commencing with Section 43000) of that Division 26.

(c) Subdivisions (a) and (b) do not apply to off-highway motor vehicles operated pursuant to Sections 38025 and 38026.5.

(d) This section does not apply, following payment of fees due for registration, during the time that registration and transfer is being withheld by the department pending the investigation of any use tax due under the Revenue and Taxation Code.

(e) Subdivision (a) does not apply to a vehicle that is towed by a tow truck on the order of a sheriff, marshal, or other official acting pursuant to a court order or on the order of a peace officer acting pursuant to this code.

(f) Subdivision (a) applies to a vehicle that is towed from a highway or offstreet parking facility under the direction of a highway service organization when that organization is providing emergency roadside assistance to that vehicle. However, the operator of a tow truck providing that assistance to that vehicle is not responsible for the violation of subdivision (a) with respect to that vehicle. The owner of an unregistered vehicle that is disabled and located on private property, shall obtain a permit from the department pursuant to Section 4003 prior to having the vehicle towed on the highway.

(g) For purposes of this section, possession of a California driver's license by the registered owner of a vehicle shall give rise to a rebuttable presumption that the owner is a resident of California.

Enacted Stats 1959 ch 3. Amended Stats 1959 ch 1233 § 1; Stats 1st Ex Sess 1960 ch 23 § 2; Stats 1963 ch 292 § 2, ch 1858 § 7.5, effective July 19, 1963, operative October 1, 1963; Stats 1st Ex Sess 1965 ch 2 § 36, effective July 12, 1965, operative August 1, 1965; Stats 1967 ch 551 § 1; Stats 1968 ch 49 § 7, effective April 25, 1968, ch 764 § 11; Stats 1975 ch 957 § 21; Stats 1976 ch 1206 § 14; Stats 1982 ch 974 § 1; Stats 1984 ch 213 § 1, effective June 20, 1984, ch 621 § 1; Stats 1987 ch 44 § 1; Stats 1988 ch 1008 § 1; Stats 1993 ch 186 § 1 (AB 1566); Stats 1996 ch 10 § 10 (AB 1869), effective February 9, 1996. Amended Stats 2000 ch 861 § 16 (SB 2084), effective September 29, 2000; Stats 2011 ch 21 § 3 (SB 94), effective May 4, 2011.

#### § 4000.1. Pollution control device; Certificate or statement

(a) Except as otherwise provided in subdivision (b), (c), or (d) of this section, or subdivision (b) of Section 43654 of the Health and Safety Code, the department shall require upon initial registration, and upon transfer of ownership and registration, of any motor vehicle subject to Part 5 (commencing with Section 43000) of Division 26 of the Health and Safety Code, a valid certificate of compliance or a certificate of noncompliance, as appropriate, issued in accordance with Section 44015 of the Health and Safety Code.

(b) With respect to new motor vehicles certified pursuant to Chapter 2 (commencing with Section 43100) of Part 5 of Division 26 of the Health and Safety Code, the department shall accept a statement completed pursuant to subdivision (b) of Section 24007 in lieu of the certificate of compliance.

(c) For purposes of determining the validity of a certificate of compliance or noncompliance submitted in compliance with the requirements of this section, the definitions of new and used motor vehicle contained in Chapter 2 (commencing with Section 39010) of Part 1 of Division 26 of the Health and Safety Code shall control.

(d) Subdivision (a) does not apply to a transfer of ownership and registration under any of the following circumstances:

(1) The initial application for transfer is submitted within the 90-day validity period of a smog certificate as specified in Section 44015 of the Health and Safety Code.

(2) The transferor is the parent, grandparent, sibling, child, grandchild, or spouse of the transferee.

(3) A motor vehicle registered to a sole proprietorship is transferred to the proprietor as owner.

(4) The transfer is between companies the principal business of which is leasing motor vehicles, if there is no change in the lessee or operator of the motor vehicle or between the lessor and the person who has been, for at least one year, the lessee's operator of the motor vehicle.

(5) The transfer is between the lessor and lessee of the motor vehicle, if there is no change in the lessee or operator of the motor vehicle.

(6) The motor vehicle was manufactured prior to the 1976 model-year.

(7) Except for diesel-powered vehicles, the transfer is for a motor vehicle that is four or less model-years old. The department shall impose a fee of eight dollars (\$8) on the transferee of a motor vehicle that is four or less model-years old. Revenues generated from the imposition of that fee shall be deposited into the Vehicle Inspection and Repair Fund.

(e) The State Air Resources Board, under Part 5 (commencing with Section 43000) of Division 26 of the Health and Safety Code, may exempt designated classifications of motor vehicles from subdivision (a) as it deems necessary, and shall notify the department of that action.

(f) Subdivision (a) does not apply to a motor vehicle when an additional individual is added as a registered owner of the motor vehicle.

(g) For purposes of subdivision (a), any collector motor vehicle, as defined in Section 259, is exempt from those portions of the test required by subdivision (f) of Section 44012 of the Health and Safety Code, if the collector motor vehicle meets all of the following criteria:

(1) Submission of proof that the motor vehicle is insured as a collector motor vehicle, as shall be required by regulation of the bureau.

(2) The motor vehicle is at least 35 model-years old.

(3) The motor vehicle complies with the exhaust emissions standards for that motor vehicle's class and model year as prescribed by the department, and the motor vehicle passes a functional inspection of the fuel cap and a visual inspection for liquid fuel leaks.

Added Stats 1963 ch 2028 § 1. Amended Stats 1965 ch 2031 § 10.5, effective July 23, 1965; Stats 1968 ch 49 § 8, effective April 25, 1968, ch 764 § 12.5, ch 1160 § 2; Stats 1969 ch 622 § 2, effective July 28, 1969; Stats 1970 ch 766 § 1; Stats 1971 ch 1073 § 4, ch 1488 § 3; Stats 1974 ch 637 § 1; Stats 1975 ch 957 § 22; Stats 1976 ch 231 § 4, ch 1206 § 15; Stats 1977 ch 1038 § 3, effective September 23, 1977, ch 1083 § 3, effective September 27, 1977; Stats 1982 ch 664 § 5, ch 892 § 3.5; Stats 1984 ch 246 § 4, ch 631 § 2; Stats 1985 ch 904 § 1; Stats 1988 ch 1544 § 58; Stats 1989 ch 1154 § 17; Stats 1993 ch 958 § 1 (SB 575); Stats 1995 ch 292 § 1 (AB 100); Stats 1996 ch 112 § 1 (SB 1528); Stats 1997 ch 801 § 2 (SB 42); Stats 2002 ch 127 § 1 (AB 2303); Stats 2004 ch 230 § 18 (SB 1107), effective August 16, 2004, ch 702 § 12 (AB 2104), effective September 23, 2004, ch 704 § 3 (AB 2683), operative April 1, 2005; Stats 2005 ch 22 § 194 (SB 1108), effective January 1, 2006; Stats 2009 ch 200 § 7 (SB 734), effective January 1, 2010.

#### § 4000.2. Pollution control compliance certificate for vehicles previously registered outside state

(a) Except as otherwise provided in subdivision (b) of Section 43654 of the Health and Safety Code, and, commencing on April 1, 2005, except for model-years exempted from biennial inspection pursuant to Section 44011 of the Health and Safety Code, the department shall require upon registration of a motor vehicle subject to Part 5 (commencing with Section 43000) of Division 26 of the Health and Safety Code, previously registered

outside this state, a valid certificate of compliance or a certificate of noncompliance, as appropriate, issued in accordance with Section 44015 of the Health and Safety Code.

(b) For the purposes of determining the validity of a certificate of compliance or noncompliance submitted in compliance with the requirements of this section, the definitions of new and used motor vehicle contained in Chapter 2 (commencing with Section 39010) of Part 1 of Division 26 of the Health and Safety Code shall control.

Added Stats 1968 ch 1307 § 2. Amended Stats 1969 ch 11 § 2, effective March 12, 1969; Stats 1970 ch 766 § 2; Stats 1975 ch 957 § 23; Stats 1976 ch 231 § 5, ch 1206 § 16; Stats 1977 ch 1083 § 4, effective September 27, 1977; Stats 1982 ch 892 § 4; Stats 1988 ch 1544 § 59; Stats 1989 ch 1154 § 18. Amended Stats 2004 ch 701 § 4.5 (SB 1615), ch 704 § 4 (AB 2683), operative April 1, 2005.

**§ 4000.3. Biennial certificate of compliance required**

(a) Except as otherwise provided in Section 44011 of the Health and Safety Code, the department shall require biennially, upon renewal of registration of any motor vehicle subject to Part 5 (commencing with Section 43000) of Division 26 of the Health and Safety Code, a valid certificate of compliance issued in accordance with Section 44015 of the Health and Safety Code. The department, in consultation with the Department of Consumer Affairs, shall develop a schedule under which vehicles shall be required biennially to obtain certificates of compliance.

(b) The Department of Consumer Affairs shall provide the department with information on vehicle classes that are subject to the motor vehicle inspection and maintenance program.

(c) The department shall include any information pamphlet provided by the Department of Consumer Affairs with notification of the inspection requirement and with its renewal notices. The information pamphlet in the renewal notice shall also notify the owner of the motor vehicle of the right to have the vehicle pretested pursuant to Section 44011.3 of the Health and Safety Code.

Added Stats 1982 ch 892 § 5. Amended Stats 1988 ch 1544 § 60; Stats 1994 ch 27 § 59 (AB 2018), effective March 30, 1994; Stats 1998 ch 938 § 2 (SB 1754).

**§ 4000.4. Mandatory registration of vehicles in California**

(a) Except as provided in Sections 6700, 6702, and 6703, any vehicle which is registered to a nonresident owner, and which is based in California or primarily used on California highways, shall be registered in California.

(b) For purposes of this section, a vehicle is deemed to be primarily or regularly used on the highways of this state if the vehicle is located or operated in this state for a greater amount of time than it is located or operated in any other individual state during the registration period in question.

Added Stats 1983 ch 409 § 3. Amended Stats 1988 ch 1008 § 2.

**§ 4000.6. Registration of commercial vehicle over 10,000 pounds**

A commercial motor vehicle, singly or in combination, that operates with a declared gross or combined gross

vehicle weight that exceeds 10,000 pounds shall be registered pursuant to Section 9400.1.

(a) A person submitting an application for registration of a commercial motor vehicle operated in combination with a semitrailer, trailer, or any combination thereof, shall include the declared combined gross weight of all units when applying for registration with the department, except as exempted under subdivision (a) of Section 9400.1.

(b) This section does not apply to pickups nor to any commercial motor vehicle or combination that does not exceed 10,000 pounds gross vehicle weight.

(c) A peace officer, as defined in Chapter 4.5 (commencing with Section 830) of Title 3 of Part 2 of the Penal Code, having reason to believe that a commercial motor vehicle is being operated, either singly or in combination, in excess of its registered declared gross or combined gross vehicle weight, may require the driver to stop and submit to an inspection or weighing of the vehicle or vehicles and an inspection of registration documents.

(d) A person shall not operate a commercial motor vehicle, either singly or in combination, in excess of its registered declared gross or combined gross vehicle weight.

(e) A violation of this section is an infraction punishable by a fine in an amount equal to the amount specified in Section 42030.1.

Added Stats 2000 ch 861 § 17 (SB 2084), effective September 29, 2000. Amended Stats 2001 ch 825 § 7.3 (SB 290), ch 826 § 8.5 (AB 1472); Stats 2004 ch 615 § 21 (SB 1233).

**§ 4001. Registration of vehicles exempt from fees**

All vehicles exempt from the payment of registration fees shall be registered as otherwise required by this code by the person having custody thereof, and he shall display upon the vehicle a license plate bearing distinguishing marks or symbols, which shall be furnished by the department free of charge.

Enacted Stats 1959 ch 3.

**§ 4002. Vehicles exempt under permit**

When moved or operated under a permit issued by the department, registration is not required of:

(a) A vehicle not previously registered while being moved or operated from a dealer's, distributor's, or manufacturer's place of business to a place where essential parts of the vehicle are to be altered or supplied.

(b) A vehicle while being moved from a place of storage to another place of storage.

(c) A vehicle while being moved to or from a garage or repair shop for the purpose of repairs or alteration.

(d) A vehicle while being moved or operated for the purpose of dismantling or wrecking the same and permanently removing it from the highways.

(e) A vehicle, while being moved from one place to another for the purpose of inspection by the department, assignment of a vehicle identification number, inspection of pollution control devices, or weighing the vehicle.

(f) A vehicle, the construction of which has not been completed, until such time as the construction thereof is completed and final weights and costs can be determined for registration purposes.

Enacted Stats 1959 ch 3. Amended Stats 1959 ch 517 § 1; Stats 1963 ch 1628 § 1; Stats 1977 ch 326 § 1.



**§ 4003. One-trip permit**

A permit, as described in Section 9258, may be issued by the department for operating any of the following vehicles, except a crane:

(a) A vehicle while being moved or operated unladen for one continuous trip from a place within this state to another place either within or without this state or from a place without this state to a place within this state.

(b) A vehicle while being moved or operated for one round trip to be completed within 60 days from one place to another for the purpose of participating as a vehicular float or display in a lawful parade or exhibition, provided that the total round trip does not exceed 100 miles.

The department may issue a quantity of permits under this subsection in booklet form upon payment of the proper fee for each permit contained in such booklet. Each permit shall be valid for only one vehicle and for only one continuous trip. Such permit shall be posted upon the windshield or other prominent place upon a vehicle and shall identify the vehicle to which it is affixed. When so affixed, such permit shall serve in lieu of California registration.

Enacted Stats 1959 ch 3. Amended Stats 1963 ch 1628 § 2; Stats 1974 ch 1430 § 2; Stats 1977 ch 326 § 2.

**§ 4003.5. One-trip permit for specified vehicles**

(a) Upon payment of the fee specified in Section 9258.5, the department shall issue to a manufacturer or dealer a one-trip permit authorizing a new trailer, semitrailer, or auxiliary dolly which has never been registered in any state, or a used trailer, semitrailer, or auxiliary dolly which is not currently registered to be moved or operated laden within, entering, or leaving this state for not more than five days as part of one continuous trip from the place of manufacture for a new vehicle, or from the place of dispatch or entry into this state for a used vehicle, to a place where the vehicle will be offered for sale.

(b) Any permit issued pursuant to this section authorizes the operation of a single trailer, semitrailer, or auxiliary dolly, and the permit shall identify the trailer, semitrailer, or auxiliary dolly authorized by make, model, and vehicle identification number. The permit shall include the name and license number of the manufacturer from whom the new vehicle is sent, or the name and license number of the dealer from whom the used vehicle is sent, the name and address of the person or business receiving the load, a description of the load being carried, and the name and license number of the dealer who will be offering the trailer, semitrailer, or auxiliary dolly for sale. Each permit shall be completed prior to operation of the trailer or semitrailer or auxiliary dolly on a highway. The permit shall be carried on the trailer, semitrailer, or auxiliary dolly to which it applies in an appropriate receptacle inaccessible from the inside of the cab and shall be readily available for inspection by a peace officer. Each permit is valid at the time of inspection by a peace officer only if it has been completed as required by the department and has been placed in the appropriate receptacle as required by this section. The manufacturer or dealer issued the permit may allow a third party to move or operate the vehicle.

(c) The privilege of securing and displaying a permit authorized pursuant to this section shall not be extended

to a manufacturer, carrier, or dealer located in a jurisdiction with which the state does not have vehicle licensing reciprocity.

(d) The privilege of securing and displaying a permit authorized pursuant to this section shall not be granted more than once without the sale and registration of the trailer, semitrailer, or auxiliary dolly.

Added Stats 1983 ch 825 § 1. Amended Stats 1984 ch 933 § 1; Stats 1985 ch 625 § 1; Stats 1986 ch 1071 § 1; Stats 1987 ch 290 § 1.

**ARTICLE 2****Original Registration****Section**

4156. Temporary permit; Exception

**§ 4156. Temporary permit; Exception**

(a) Notwithstanding any other provision of this code, and except as provided in subdivision (b), the department in its discretion may issue a temporary permit to operate a vehicle when a payment of fees has been accepted in an amount to be determined by, and paid to the department, by the owner or other person in lawful possession of the vehicle. The permit shall be subject to the terms and conditions, and shall be valid for the period of time, that the department shall deem appropriate under the circumstances.

(b)(1) The department shall not issue a temporary permit pursuant to subdivision (a) to operate a vehicle for which a certificate of compliance is required pursuant to Section 4000.3, and for which that certificate of compliance has not been issued, unless the department is presented with sufficient evidence, as determined by the department, that the vehicle has failed its most recent smog check inspection.

(2) Not more than one temporary permit may be issued pursuant to this subdivision to a vehicle owner in a two-year period.

(3) A temporary permit issued pursuant to paragraph (1) is valid for either 60 days after the expiration of the registration of the vehicle or 60 days after the date that vehicle is removed from nonoperation, whichever is applicable at the time that the temporary permit is issued.

(4) A temporary permit issued pursuant to paragraph (1) is subject to Section 9257.5.

Enacted Stats 1959 ch 3. Amended Stats 1959 ch 1478 § 1; Stats 2008 ch 451 § 1 (AB 2241), effective January 1, 2009; Stats 2009 ch 140 § 179 (AB 1164), effective January 1, 2010.

**ARTICLE 4****Evidences of Registration****Section**

4463. Alteration or falsification of evidence of ownership, registration, or identification; Alteration or falsification of plates, placards, stickers; Violation as infraction; Penalty

**§ 4463. Alteration or falsification of evidence of ownership, registration, or identification; Alteration or falsification of plates, placards, stickers; Violation as infraction; Penalty**

(a) A person who, with intent to prejudice, damage, or defraud, commits any of the following acts is guilty of a

felony and upon conviction thereof shall be punished by imprisonment pursuant to subdivision (h) of Section 1170 of the Penal Code for 16 months or two or three years, or by imprisonment in a county jail for not more than one year:

(1) Alters, forges, counterfeits, or falsifies a certificate of ownership, registration card, certificate, license, license plate, device issued pursuant to Section 4853, special plate, or permit provided for by this code or a comparable certificate of ownership, registration card, certificate, license, license plate, device comparable to that issued pursuant to Section 4853, special plate, or permit provided for by a foreign jurisdiction, or alters, forges, counterfeits, or falsifies the document, device, or plate with intent to represent it as issued by the department, or alters, forges, counterfeits, or falsifies with fraudulent intent an endorsement of transfer on a certificate of ownership or other document evidencing ownership, or with fraudulent intent displays or causes or permits to be displayed or have in his or her possession a blank, incomplete, canceled, suspended, revoked, altered, forged, counterfeit, or false certificate of ownership, registration card, certificate, license, license plate, device issued pursuant to Section 4853, special plate, or permit.

(2) Utters, publishes, passes, or attempts to pass, as true and genuine, a false, altered, forged, or counterfeited matter listed in paragraph (1) knowing it to be false, altered, forged, or counterfeited.

(b) A person who, with intent to prejudice, damage, or defraud, commits any of the following acts is guilty of a misdemeanor, and upon conviction thereof shall be punished by imprisonment in a county jail for six months, a fine of not less than five hundred dollars (\$500) and not more than one thousand dollars (\$1,000), or both that fine and imprisonment, which penalty shall not be suspended:

(1) Forges, counterfeits, or falsifies a disabled person placard or a comparable placard relating to parking privileges for disabled persons provided for by a foreign jurisdiction, or forges, counterfeits, or falsifies a disabled person placard with intent to represent it as issued by the department.

(2) Passes, or attempts to pass, as true and genuine, a false, forged, or counterfeit disabled person placard knowing it to be false, forged, or counterfeited.

(3) Acquires, possesses, sells, or offers for sale a genuine or counterfeit disabled person placard.

(c) A person who, with fraudulent intent, displays or causes or permits to be displayed a forged, counterfeit, or false disabled person placard, is subject to the issuance of a notice of parking violation imposing a civil penalty of not less than two hundred fifty dollars (\$250) and not more than one thousand dollars (\$1,000), for which enforcement shall be governed by the procedures set forth in Article 3 (commencing with Section 40200) of Chapter 1 of Division 17 or is guilty of a misdemeanor punishable by imprisonment in a county jail for six months, a fine of not less than two hundred fifty dollars (\$250) and not more than one thousand dollars (\$1,000), or both that fine and imprisonment, which penalty shall not be suspended.

(d) For purposes of subdivision (b) or (c), "disabled person placard" means a placard issued pursuant to Section 22511.55 or 22511.59.

(e) A person who, with intent to prejudice, damage, or defraud, commits any of the following acts is guilty of an infraction, and upon conviction thereof shall be punished by a fine of not less than one hundred dollars (\$100) and not more than two hundred fifty dollars (\$250) for a first offense, not less than two hundred fifty dollars (\$250) and not more than five hundred dollars (\$500) for a second offense, and not less than five hundred dollars (\$500) and not more than one thousand dollars (\$1,000) for a third or subsequent offense, which penalty shall not be suspended:

(1) Forges, counterfeits, or falsifies a Clean Air Sticker or a comparable clean air sticker relating to high occupancy vehicle lane privileges provided for by a foreign jurisdiction, or forges, counterfeits, or falsifies a Clean Air Sticker with intent to represent it as issued by the department.

(2) Passes, or attempts to pass, as true and genuine, a false, forged, or counterfeit Clean Air Sticker knowing it to be false, forged, or counterfeited.

(3) Acquires, possesses, sells, or offers for sale a counterfeit Clean Air Sticker.

(4) Acquires, possesses, sells, or offers for sale a genuine Clean Air Sticker separate from the vehicle for which the department issued that sticker.

(f) As used in this section, "Clean Air Sticker" means a label or decal issued pursuant to Sections 5205.5 and 21655.9.

Enacted Stats 1959 ch 3. Amended Stats 1967 ch 1110 § 3; Stats 1971 ch 605 § 1; Stats 1976 ch 1139 § 335, operative July 1, 1977; Stats 1980 ch 589 § 1; Stats 1982 ch 975 § 3; Stats 1985 ch 623 § 1; Stats 1988 ch 624 § 2; Stats 1991 ch 630 § 1 (AB 1346); Stats 1994 ch 1149 § 3 (AB 2878); Stats 2000 ch 524 § 3 (AB 1792); Stats 2008 ch 417 § 1 (SB 1720), effective January 1, 2009; Stats 2009 ch 415 § 3 (AB 144), effective January 1, 2010; Stats 2011 ch 15 § 600 (AB 109), effective April 4, 2011, operative October 1, 2011.

## ARTICLE 6

### Refusal of Registration

#### Section

4750.1. Application for model year determination; Referee station inspection; Fee

#### § 4750.1. Application for model year determination; Referee station inspection; Fee

(a) If the department receives an application for registration of a specially constructed passenger vehicle or pickup truck after it has registered 500 specially constructed vehicles during that calendar year pursuant to Section 44017.4 of the Health and Safety Code, and the vehicle has not been previously registered, the vehicle shall be assigned the same model-year as the calendar year in which the application is submitted, for purposes of determining emissions inspection requirements for the vehicle.

(b)(1) If the department receives an application for registration of a specially constructed passenger vehicle or pickup truck that has been previously registered after it has registered 500 specially constructed vehicles during that calendar year pursuant to Section 44017.4 of the Health and Safety Code, and the application requests a model-year determination different from the model-year assigned in the previous registration, the application for registration shall be denied and the vehicle owner is

subject to the emission control and inspection requirements applicable to the model-year assigned in the previous registration.

(2) For a vehicle participating in the amnesty program in effect from July 1, 2011, to June 30, 2012, pursuant to Section 9565, the model-year of the previous registration shall be the calendar year of the year in which the vehicle owner applied for amnesty. However, a denial of an application for registration issued pursuant to this paragraph does not preclude the vehicle owner from applying for a different model-year determination and application for registration under Section 44017.4 of the Health and Safety Code in a subsequent calendar year.

(c)(1) The Bureau of Automotive Repair may charge the vehicle owner who applies to participate in the amnesty program a fee for each referee station inspection conducted pursuant to Section 9565. The fee shall be one hundred sixty dollars (\$160) and shall be collected by the referee station performing the inspection.

(2) A contract to perform referee services may authorize direct compensation to the referee contractor from the inspection fees collected pursuant to paragraph (1). The referee contractor shall deposit the inspection fees collected from the vehicle owner into a separate trust account that the referee contractor shall account for and manage in accordance with generally accepted accounting standards and principles. Where the department conducts the inspections pursuant to Section 9565, the inspection fees collected by the department shall be deposited into the Vehicle Inspection and Repair Fund.

Added Stats 2002 ch 693 § 2 (SB 1578). Amended Stats 2008 ch 420 § 2 (AB 619), effective January 1, 2009; Stats 2009 ch 235 § 1 (AB 318), effective January 1, 2010; Stats 2010 ch 388 § 1, (AB 2461), effective January 1, 2011.

## ARTICLE 8 Special Plates

Section  
5004. Vehicles of historic value

### § 5004. Vehicles of historic value

(a) Notwithstanding any other provision of this code, any owner of a vehicle described in paragraph (1), (2), or (3) which is operated or moved over the highway primarily for the purpose of historical exhibition or other similar purpose shall, upon application in the manner and at the time prescribed by the department, be issued special identification plates for the vehicle:

(1) A motor vehicle with an engine of 16 or more cylinders manufactured prior to 1965.

(2) A motor vehicle manufactured in the year 1922 or prior thereto.

(3) A vehicle which was manufactured after 1922, is at least 25 years old, and is of historic interest.

(b) The special identification plates assigned to motor vehicles with an engine of 16 or more cylinders manufactured prior to 1965 and to any motor vehicle manufactured in the year 1922 and prior thereto shall run in a separate numerical series, commencing with "Horseless Carriage No. 1".

The special identification plates assigned to vehicles specified in paragraph (3) of subdivision (a) shall run in

a separate numerical series, commencing with "Historical Vehicle No. 1".

Each series of plates shall have different and distinguishing colors.

(c) A fee of twenty-five dollars (\$25) shall be charged for the initial issuance of the special identification plates. Such plates shall be permanent and shall not be required to be replaced. If such special identification plates become damaged or unserviceable in any manner, replacement for the plates may be obtained from the department upon proper application and upon payment of such fee as is provided for in Section 9265.

(d) All funds received by the department in payment for such identification plates or the replacement thereof shall be deposited in the California Environmental License Plate Fund.

(e) These vehicles shall not be exempt from the equipment provisions of Sections 26709, 27150, and 27600.

(f) As used in this section, a vehicle is of historic interest if it is collected, restored, maintained, and operated by a collector or hobbyist principally for purposes of exhibition and historic vehicle club activities.

Enacted Stats 1959 ch 3. Amended Stats 1961 ch 1285 § 2, operative January 1, 1962; Stats 1965 ch 1389 § 1; Stats 1971 ch 1437 § 4, ch 1448 § 4, operative January 1, 1972; Stats 1974 ch 1012 § 5; Stats 1981 ch 415 § 2 (ch 415 prevails), ch 714 § 438; Stats 1984 ch 918 § 1.

## ARTICLE 8.3

### Historic and Special Interest Vehicles

Section  
5050. Legislative findings and declarations  
5051. Definitions  
5052. Storage; Manner of maintenance

### § 5050. Legislative findings and declarations

The Legislature finds and declares that constructive leisure pursuits by California citizens is most important. This article is intended to encourage responsible participation in the hobby of collecting, preserving, restoring, and maintaining motor vehicles of historic and special interest, which hobby contributes to the enjoyment of the citizen and the preservation of California's automotive memorabilia.

Added Stats 1975 ch 753 § 1.

### § 5051. Definitions

As used in this article, unless the context otherwise requires:

(a) "Collector" is the owner of one or more vehicles described in Section 5004 or of one or more special interest vehicles, as defined in this article, who collects, purchases, acquires, trades, or disposes of the vehicle, or parts thereof, for his or her own use, in order to preserve, restore, and maintain the vehicle for hobby or historical purposes.

(b) "Special interest vehicle" is a vehicle of an age that is unaltered from the manufacturer's original specifications and, because of its significance, including, but not limited to, an out-of-production vehicle or a model of less than 2,000 sold in California in a model-year, is collected, preserved, restored, or maintained by a hobbyist as a leisure pursuit.

(c) "Parts car" is a motor vehicle that is owned by a collector to furnish parts for restoration or maintenance of a special interest vehicle or a vehicle described in Section 5004, thus enabling a collector to preserve, restore, and maintain a special interest vehicle or a vehicle described in Section 5004.

(d) "Street rod vehicle" is a motor vehicle, other than a motorcycle, manufactured in, or prior to, 1948 that is individually modified in its body style or design, including through the use of nonoriginal or reproduction components, and may include additional modifications to other components, including, but not limited to, the engine, drivetrain, suspension, and brakes in a manner that does not adversely affect its safe performance as a motor vehicle or render it unlawful for highway use.

Added Stats 1975 ch 753 § 1. Amended Stats 1990 ch 929 § 2 (AB 3449); Stats 2006 ch 574 § 6 (AB 2520), effective January 1, 2007.

**§ 5052. Storage; Manner of maintenance**

Except as otherwise provided by local ordinance, a collector may maintain one or more vehicles described in Section 5051, whether currently licensed or unlicensed, or whether operable or inoperable, in outdoor storage on private property, if every such vehicle and outdoor storage area is maintained in such manner as not to constitute a health hazard and is located away from public view, or screened from ordinary public view, by means of a suitable fence, trees, shrubbery, opaque covering, or other appropriate means.

Added Stats 1975 ch 753 § 1.

**ARTICLE 12**

**Surrender of Registration Documents and License Plates**

Section

- 5500. Delivery of certificate of ownership, registration card and license plate prior to disassembling vehicle
- 5501. Procedures when vehicle is to be dismantled
- 5505. Application for registration of salvage or dismantled vehicle
- 5506. Certificate of inspection or vehicle verification form

**§ 5500. Delivery of certificate of ownership, registration card and license plate prior to disassembling vehicle**

(a) Any person, other than a licensed dismantler, desiring to disassemble a vehicle of a type required to be registered under this code, either partially or totally, with the intent to use as parts only, to reduce to scrap, or to construct another vehicle shall deliver to the department the certificate of ownership, the registration card, and the license plates last issued to the vehicle before dismantling may begin.

(b) Any person who is convicted of violating subdivision (a) shall be punished upon a first conviction by imprisonment in the county jail for not less than five days or more than six months, or by a fine of not less than fifty dollars (\$50) or more than five hundred dollars (\$500), or by both that fine and imprisonment; and, upon a second or any subsequent conviction, by imprisonment in the county jail for not less than 30 days or more than one year, or by a fine of not less than two hundred fifty dollars (\$250) or more than one thousand dollars (\$1,000), or by both that fine and imprisonment.

Added Stats 1983 ch 1286 § 21. Amended Stats 1985 ch 1022 § 4.

**§ 5501. Procedures when vehicle is to be dismantled**

The provisions of Sections 4457, 4458, and 4459 shall not apply when a vehicle is reported for dismantling. However, any person desiring to dismantle a vehicle shall, in accordance with Section 5500 or 11520, surrender to the department the certificate of ownership, registration card, and license plate or plates last issued for the vehicle. In the event the person so reporting is unable to furnish the certificate of ownership, registration card, and license plate or plates last issued to the vehicle, or any of them, the department may receive the report and application, examine into the circumstances of the case, and many require the filing of suitable affidavits, or other information or documents. No duplicate certificate of ownership, registration card, license plate or plates will be issued when a vehicle is reported for dismantling. No fees shall be required for acceptance of any affidavit provided pursuant to this section or on account of any stolen, lost or damaged certificate, card, plate or plates or duplicates thereof, unless the vehicle is subsequently registered in accordance with Section 11519.

Added Stats 1983 ch 1286 § 21.

**§ 5505. Application for registration of salvage or dismantled vehicle**

(a) This section applies to any vehicle reported to be a total loss salvage vehicle pursuant to Section 11515 and to any vehicle reported for dismantling pursuant to Section 5500 or 11520.

(b) Whenever an application is made to the Department of Motor Vehicles to register a vehicle described in subdivision (a), that department shall inspect the vehicle to determine its proper identity or request that the inspection be performed by the Department of the California Highway Patrol. An inspection by the Department of Motor Vehicles shall not preclude that department from referring the vehicle to the Department of the California Highway Patrol for an additional inspection if deemed necessary.

(c) The Department of the California Highway Patrol shall inspect, on a random basis, those vehicles described in subdivision (a) that have been presented to the Department of Motor Vehicles for registration after completion of the reconstruction process to determine the proper identity of those vehicles. The vehicle being presented for inspection shall be a complete vehicle, in legal operating condition. If the vehicle was originally manufactured with a "supplemental restraint system" as defined in Section 593, the reconstructed vehicle shall also be equipped with a supplemental restraint system in good working order that meets applicable federal motor vehicle safety standards and conforms to the manufacturer's specifications for that vehicle. The inspection conducted pursuant to this subdivision shall be a comprehensive, vehicle identification number inspection.

(d) A salvage vehicle rebuilder, as defined in Section 543.5, or other individual in possession of a vehicle described in subdivision (a), who is submitting the vehicle for registration as described in subdivision (b), shall have available, and shall present upon demand of

the Department of the California Highway Patrol, bills of sale, invoices, or other acceptable proof of ownership of component parts, and invoices for minor component parts. Additionally, bills of sale and invoices shall include the year, make, model, and the vehicle identification number of the vehicle from which the parts were removed or sold, the name and signature of the person from whom the parts were acquired, and his or her address, and telephone number. To assist in the identification of the seller of new or used parts, the number of the seller's driver's license, identification card, social security card, or Federal Employer Identification Number shall be provided by the seller to the buyer on the bills of sale and invoice. The seller of a salvage vehicle, or the agent of the seller, shall inform the purchaser of the vehicle that ownership documentation for certain replacement parts used in the repair of the vehicle will be required in the inspection required under this section.

(e) As used in this section, the term "component parts for passenger motor vehicles" includes supplemental restraint systems, the cowl or firewall, front-end assembly, rear clip, including the roof panel, the roof panel when installed separately, and the frame or any portion thereof, or in the case of a unitized body, the supporting structure that serves as the frame, each door, the hood, each fender or quarter panel, deck lid or hatchback, each bumper, both T-tops, replacement transmissions or transaxles, and a replacement motor.

(1) As used in this subdivision, "front-end assembly" includes all of the following: hood, fenders, bumper, and radiator supporting members for these items. For vehicles with a unitized body, the front-end assembly also includes the frame support members.

(2) As used in this subdivision, "rear clip" includes the roof, quarter panels, trunk lid, floor pan, and the support members for each item.

(f) As used in this section, "major component parts for trucks, truck-type or bus-type vehicles" includes the cab, the frame or any portion thereof, and, in the case of a unitized body, the supporting structure which serves as a frame, the cargo compartment floor panel or passenger compartment floor pan, roof panel, and replacement transmissions or transaxles, and replacement motors, each door, hood, each fender or quarter panel, each bumper, and the tailgate. All component parts identified in subdivision (e), common to a truck, truck-type or bus-type vehicle, not listed in this section, shall be considered as included in this section if the part is replaced.

(1) "Major component parts for motorcycles" includes the engine or motor, transmission or transaxle, frame, front fork, and crankcase.

(2) "Minor component parts for motorcycles" includes the fairing and any other body molding.

(g) If the vehicle identification number, year, make, or model required under subdivision (d) cannot be determined, the Department of the California Highway Patrol may accept, in lieu of that information, a certification on a form provided by that department, signed by the person submitting the vehicle for inspection, that the part was not obtained by means of theft or fraud.

Added Stats 1995 ch 684 § 2 (SB 549), effective October 10, 1995, operative January 1, 1997. Amended Stats 1996 ch 450 § 1 (SB 1713),

operative until January 1, 2003. Amended Stats 2002 ch 670 § 7 (SB 1331).

#### § 5506. Certificate of inspection or vehicle verification form

No salvage vehicle rebuilder may resell or transfer ownership of any vehicle that is subject to inspection as provided in Section 5505, unless either a certificate of inspection issued by the Department of the California Highway Patrol, or vehicle verification form completed by an authorized employee of the Department of Motor Vehicles is provided to the buyer upon sale or transfer. Responsibility for compliance with this section shall rest with the salvage vehicle rebuilder selling or transferring the vehicle. This section shall not apply to a salvage vehicle rebuilder who has applied for and received a title in accordance with Section 5505.

Added Stats 2002 ch 670 § 8 (SB 1331).

## CHAPTER 2

### Transfers of Title or Interest

#### ARTICLE 2

### Endorsement and Delivery of Documents

Section  
5751.5. Emissions statement; Warning to buyer

#### § 5751.5. Emissions statement; Warning to buyer

(a) Upon transfer of the title or interest of the registered owner of a motor vehicle that is subject to Part 5 (commencing with Section 43000) of Division 26 of the Health and Safety Code, if no certificate of compliance or certificate of noncompliance is submitted to the department pursuant to the exemptions described in paragraph (1) of subdivision (d) of Section 4000.1, the transferor of that vehicle shall sign and deliver to the transferee, upon completion of the transaction, the original copy of a statement, under penalty of perjury, that he or she has not modified the emissions system of the vehicle and does not have any personal knowledge of anyone else modifying the system in a manner that causes the emission system to fail to qualify for the issuance of a certificate of compliance pursuant to Section 44015 of the Health and Safety Code. The transferor shall keep a duplicate copy of the statement delivered to the transferee pursuant to this section. The department shall prescribe and make available to transferors the necessary forms to comply with this subdivision.

(b) Any form prescribed by the department pursuant to subdivision (a) shall contain the following statement and a space for the signatures of the transferor and transferee at the end of the statement:

"WARNING TO THE BUYER

"A valid certificate of compliance was submitted to the Department of Motor Vehicles with an application for the renewal of registration of this vehicle. If an application for transfer is submitted to the department within the 90-day validity period of the smog certification, no new

smog certification will be required. However, at present, you may be purchasing a vehicle that may not be in compliance with specified emission standards.

“By signing this statement, you acknowledge that the seller is not required to provide you with an additional certificate of compliance prior to the completion of this transaction.

“You may have this vehicle tested at a licensed smog check station prior to completion of this transaction to verify compliance. If the vehicle passes the test, you shall be responsible for the costs of the test. If the vehicle fails the test, the seller is obligated to reimburse you the cost of having the vehicle tested and, without expense to you, must have the vehicle repaired to comply with specified emission standards prior to completion of this transaction.

---

(Transferor) (Date)

---

(Transferee) (Date)”

Added Stats 1993 ch 958 § 2 (SB 575). Amended Stats 2002 ch 127 § 2 (AB 2303); Stats 2004 ch 650 § 7 (AB 3047).

## CHAPTER 6

### Registration and Weight Fees

#### ARTICLE 2

#### Registration Fees

Section

- 9250. Fee for registration of vehicles and trailer coaches; Applicability; Use of money collected
- 9250.1. (Repealed January 1, 2024) Increase in registration fee; Use of increase
- 9250.2. (First of two; Repealed January 1, 2024) Surcharge on registration fees
- 9250.2. (Second of two; Operative January 1, 2024) Surcharge on registration fees
- 9250.18. Collection of administrative fees; Transmission of revenues to Vehicle Inspection and Repair Fund
- 9255.2. Fee for registration or transfer of ownership
- 9257.5. Fee for temporary permit where certificate of compliance required; Deposit
- 9258. Fee for one-trip permit

**§ 9250. Fee for registration of vehicles and trailer coaches; Applicability; Use of money collected**

(a) A registration fee of thirty-one dollars (\$31) shall be paid to the department for the registration of every vehicle or trailer coach of a type subject to registration under this code, except those vehicles that are expressly exempted under this code from the payment of registration fees. This subdivision applies to all of the following:

(1) The initial or original registration, on or after January 1, 2004, but before July 1, 2011, of any vehicle not previously registered in this state.

(2) The renewal of registration of any vehicle for which the registration period expires on or after January 1, 2004, but before July 1, 2011, regardless of whether a renewal application was mailed to the registered owner prior to January 1, 2004.

(b) A registration fee of forty-three dollars (\$43) shall be paid to the department for the registration of each vehicle or trailer coach of a type subject to registration under this code, except those vehicles that are expressly exempted under this code from the payment of registration fees. This subdivision applies to all of the following:

(1) The initial or original registration, on or after July 1, 2011, of any vehicle not previously registered in this state.

(2) The renewal of registration of any vehicle for which the registration period expires on or after July 1, 2011, regardless of whether a renewal application was mailed to the registered owner prior to July 1, 2011.

(c) The registration fee imposed under this section applies to all vehicles described in Section 5004, whether or not special identification plates are issued to that vehicle.

(d) Trailer coaches are subject to the registration fee provided in subdivision (a) or (b) for each unit of the trailer coach.

(e) The amounts collected pursuant to the increase in the registration fee as specified in subdivision (b) shall be used only for costs incurred in connection with the regulation of vehicles, including administrative costs for vehicle registration.

Added Stats 1998 ch 877 § 39 (AB 2132). Amended Stats 2003 ch 719 § 10 (SB 1055); Stats 2011 ch 35 § 10 (SB 89), effective June 30, 2011.

**§ 9250.1. (Repealed January 1, 2024) Increase in registration fee; Use of increase**

(a) Beginning July 1, 2008, the fee described in Section 9250 shall be increased by three dollars (\$3).

(b) Two dollars (\$2) of the increase shall be deposited into the Alternative and Renewable Fuel and Vehicle Technology Fund created by Section 44273 of the Health and Safety Code, and one dollar (\$1) shall be deposited into the Enhanced Fleet Modernization Subaccount created by Section 44126 of the Health and Safety Code.

(c) This section shall remain in effect only until January 1, 2024, and as of that date is repealed, unless a later enacted statute, that is enacted before January 1, 2024, deletes or extends that date.

Added Stats 2007 ch 750 § 6 (AB 118), effective January 1, 2008, repealed January 1, 2016. Amended Stats 2013 ch 401 § 35 (AB 8), effective September 28, 2013, repealed January 1, 2024.

**§ 9250.2. (First of two; Repealed January 1, 2024) Surcharge on registration fees**

(a) The department, if requested by the Sacramento Metropolitan Air Quality Management District pursuant to Section 41081 of the Health and Safety Code, shall impose and collect a surcharge on the registration fees for every motor vehicle registered in that district, not to exceed the amount of six dollars (\$6), as specified by the governing body of that district.

(b) This section shall remain in effect only until January 1, 2024, and as of that date is repealed, unless a later enacted statute, that is enacted before January 1, 2024, deletes or extends that date.

Added Stats 1988 ch 1541 § 5. Amended Stats 2004 ch 707 § 15 (AB 923), repealed January 1, 2015; Stats 2013 ch 401 § 36 (AB 8), effective September 28, 2013, repealed January 1, 2024.

**§ 9250.2. (Second of two; Operative January 1, 2024) Surcharge on registration fees**

(a) The department, if requested by the Sacramento Metropolitan Air Quality Management District pursuant to Section 41081 of the Health and Safety Code, shall impose and collect a surcharge on the registration fees for every motor vehicle registered in that district, not to exceed

four dollars (\$4).

(b) This section shall become operative on January 1, 2024.

Added Stats 2004 ch 707 § 15.5 (AB 923), operative January 1, 2015. Amended Stats 2013 ch 401 § 37 (AB 8), effective September 28, 2013, operative January 1, 2024.

**§ 9250.18. Collection of administrative fees; Transmission of revenues to Vehicle Inspection and Repair Fund**

(a) The department shall collect the administrative fee established pursuant to Sections 44081 and 44081.6 of the Health and Safety Code upon the renewal of registration or transfer of ownership of any motor vehicle registered in the state.

(b) On a monthly basis, after deducting its reasonable costs, the department shall transmit all revenues, including accrued interest, received pursuant to this section, for deposit in the Vehicle Inspection and Repair Fund, for use by the Department of Consumer Affairs pursuant to Chapter 5 (commencing with Section 44000) of Part 5 of Division 26 of the Health and Safety Code. Alternatively, the department and the Department of Consumer Affairs may, by interagency agreement, establish a procedure for the Department of Consumer Affairs to reimburse the department for its reasonable costs incurred in collecting the administrative fees.

Added Stats 1994 ch 27 § 61 (AB 2018), effective March 30, 1994. Amended Stats 1994 ch 1220 § 54.2 (AB 3132), effective September 30, 1994.

**§ 9255.2. Fee for registration or transfer of ownership**

(a) In addition to any other fees specified in this code and the Revenue and Taxation Code, a fee of not more than fifty dollars (\$50), as determined by the Department of the California Highway Patrol to cover the costs of implementing and conducting the inspection program required under Section 5505, shall be paid to the Depart-

ment of Motor Vehicles at the time inspection is made for initial registration or transfer of ownership of a vehicle included in paragraphs (1) and (2) of subdivision (b) of Section 4453.

(b) The fees collected pursuant to subdivision (a) shall be deposited in the Motor Vehicle Account in the State Transportation Fund. The money deposited in the account shall be available, upon appropriation by the Legislature, for distribution as follows:

(1) Not more than three dollars (\$3) of each fee collected under subdivision (a) to the Department of Motor Vehicles.

(2) The remainder to the Department of the California Highway Patrol.

Added Stats 1994 ch 1008 § 12 (SB 1833), operative July 1, 1995. Amended Stats 1996 ch 450 § 2 (SB 1713), operative until January 1, 2003. Amended Stats 2002 ch 670 § 9 (SB 1331).

**§ 9257.5. Fee for temporary permit where certificate of compliance required; Deposit**

(a) Except as provided in subdivision (c), a fee of fifty dollars (\$50) shall be paid for each temporary permit issued pursuant to Section 4156 when a certificate of compliance is required pursuant to Section 4000.3.

(b) After deducting its administrative costs, the department shall deposit fees collected pursuant to subdivision (a) in the High Polluter Repair or Removal Account in the Vehicle Inspection and Repair Fund.

(c) The department shall not charge a fee pursuant to subdivision (a) if the department is presented at the time the temporary permit is issued with sufficient evidence, as determined by the department, that the owner of the vehicle is an income eligible applicant who had his or her vehicle accepted into the Bureau of Automotive Repair Consumer Assistance Program as established pursuant to Chapter 5 (commencing with Section 44000) of Part 5 of Division 26 of the Health and Safety Code.

Added Stats 2008 ch 451 § 2 (AB 2241), effective January 1, 2009.

**§ 9258. Fee for one-trip permit**

A fee of fifteen dollars (\$15) shall be paid to the department for each one-trip permit issued pursuant to Section 4003.

Enacted Stats 1959 ch 3. Amended Stats 1961 ch 58 § 21, effective March 31, 1961; Stats 1963 ch 1628 § 3; Stats 1981 ch 541 § 28, effective September 17, 1981, operative January 1, 1982. Amended Stats 2003 ch 719 § 15 (SB 1055).

## DIVISION 4

### Special Antitheft Laws

#### CHAPTER 5

#### Motor Vehicle Theft Prevention

Section  
10904. Public education campaign

**§ 10904. Public education campaign**

The commissioner may develop a public education campaign to deter participation in auto insurance fraud and to encourage reporting of fraudulent claims.

Added Stats 2000 ch 867 § 22 (SB 1988).

**DIVISION 5**

**Occupational Licensing and Business Regulations**

**CHAPTER 3**

**Automobile Dismantlers**

Section

11515. Total loss salvage vehicles; Duties of insurance company, salvage pool, owner, etc.; Certificate of ownership; Salvage certificate; Punishment for violations; Civil penalty

**§ 11515. Total loss salvage vehicles; Duties of insurance company, salvage pool, owner, etc.; Certificate of ownership; Salvage certificate; Punishment for violations; Civil penalty**

(a)(1) Whenever an insurance company makes a total loss settlement on a total loss salvage vehicle, the insurance company, an occupational licensee of the department authorized by the insurance company, or a salvage pool authorized by the insurance company, within 10 days from the settlement of the loss, shall forward the properly endorsed certificate of ownership or other evidence of ownership acceptable to the department, the license plates, and a fee in the amount of fifteen dollars (\$15), to the department. An occupational licensee of the department may submit a certificate of license plate destruction in lieu of the actual license plate.

(2) If an insurance company, an occupational licensee of the department authorized by the insurance company, or a salvage pool authorized by the insurance company is unable to obtain the properly endorsed certificate of ownership or other evidence of ownership acceptable to the department within 30 days following oral or written acceptance by the owner of an offer of an amount in settlement of a total loss, that insurance company, licensee, or salvage pool, on a form provided by the department and signed under penalty of perjury, may request the department to issue a salvage certificate for the vehicle. The request shall include and document that the requester has made at least two written attempts to obtain the certificate of ownership or other acceptable evidence of title, and shall include the license plates and fee described in paragraph (1).

(3) The department, upon receipt of the certificate of ownership, other evidence of title, or properly executed request described in paragraph (2), the license plates, and the fee, shall issue a salvage certificate for the vehicle.

(b) Whenever the owner of a total loss salvage vehicle retains possession of the vehicle, the insurance company shall notify the department of the retention on a form prescribed by the department. The insurance company shall also notify the insured or owner of the insured's or owner's responsibility to comply with this subdivision. The owner shall, within 10 days from the settlement of the loss, forward the properly endorsed certificate of ownership or other evidence of ownership acceptable to the department, the license plates, and a fee in the amount of fifteen dollars (\$15) to the department. The department, upon receipt of the certificate of ownership or other evidence of title, the license plates, and the fee, shall issue a salvage certificate for the vehicle.

(c) Whenever a total loss salvage vehicle is not the subject of an insurance settlement, the owner shall, within 10 days from the loss, forward the properly endorsed certificate of ownership or other evidence of ownership acceptable to the department, the license plates, and a fee in the amount of fifteen dollars (\$15) to the department.

(d) Whenever a total loss salvage vehicle is not the subject of an insurance settlement, a self-insurer, as defined in Section 16052, shall, within 10 days from the loss, forward the properly endorsed certificate of ownership or other evidence of ownership acceptable to the department, the license plates, and a fee in the amount of fifteen dollars (\$15) to the department.

(e) Prior to the sale or disposal of a total loss salvage vehicle, the owner, owner's agent, or salvage pool, shall obtain a properly endorsed salvage certificate and deliver it to the purchaser within 10 days after payment in full for the salvage vehicle and shall also comply with Section 5900. The department shall accept the endorsed salvage certificate in lieu of the certificate of ownership or other evidence of ownership when accompanied by an application and other documents and fees, including, but not limited to, the fees required by Section 9265, as may be required by the department.

(f) This section does not apply to a vehicle that has been driven or taken without the consent of the owner thereof, until the vehicle has been recovered by the owner and only if the vehicle is a total loss salvage vehicle.

(g) A violation of subdivision (a), (b), (d), or (e) is a misdemeanor, pursuant to Section 40000.11. Notwithstanding Section 40000.11, a violation of subdivision (c) is an infraction, except that, if committed with the intent to defraud, a violation of subdivision (c) is a misdemeanor.

(h)(1) A salvage certificate issued pursuant to this section shall include a statement that the seller and subsequent sellers that transfer ownership of a total loss vehicle pursuant to a properly endorsed salvage certificate are required to disclose to the purchaser at, or prior to, the time of sale that the vehicle has been declared a total loss salvage vehicle.

(2) Effective on and after the department includes in the salvage certificate form the statement described in paragraph (1), a seller who fails to make the disclosure described in paragraph (1) shall be subject to a civil penalty of not more than five hundred dollars (\$500).

(3) Nothing in this subdivision affects any other civil remedy provided by law, including, but not limited to, punitive damages.

Added Stats 1980 ch 629 § 5. Amended Stats 1981 ch 714 § 442; Stats 1984 ch 1026 § 1; Stats 1986 ch 952 § 3; Stats 1991 ch 470 § 1 (AB 779), operative July 1, 1992; Stats 1998 ch 453 § 1 (AB 218); Stats 2002 ch 826 § 1 (SB 2076); Stats 2003 ch 719 § 20 (SB 1055); Stats 2006 ch 412 § 1 (AB 1122), effective January 1, 2007.

**CHAPTER 7**

**Sale of Automobile Parts**

Section

12000. Investigation and enforcement



## Section

12001. Invoice; Required information  
 12002. Defective vehicle parts  
 12003. Violation

**§ 12000. Investigation and enforcement**

The Bureau of Automotive Repair in the Department of Consumer Affairs shall enforce the provisions of this chapter. The Bureau of Automotive Repair shall investigate and inspect retail outlets to insure compliance with this chapter.

Added Stats 1975 ch 678 § 70.

**§ 12001. Invoice; Required information**

(a) Any person who sells and installs new parts in passenger cars, in the ordinary course of his business, shall provide the customer with an invoice which identifies by brand name, or other comparable designation, the part or parts installed.

(b) Any person who sells and installs used or factory rebuilt parts in passenger cars, in the ordinary course of his business, shall provide the customer with an invoice which specifically designates the used part or parts installed.

(c) This section shall not apply to any fitting or other device necessary to the installation of any new, used or factory rebuilt part subject to the provisions of this section.

Added Stats 1975 ch 678 § 70.

**§ 12002. Defective vehicle parts**

No person shall knowingly manufacture, sell, or install in any vehicle, any vehicle part which, under the provisions of the National Traffic and Motor Vehicle Safety Act of 1966 (15 U.S.C., Sec. 1381 et seq.), is, or has been, determined to be defective and subject to customer notification or recall.

Added Stats 1975 ch 678 § 70.

**§ 12003. Violation**

Any violation of this chapter shall be a misdemeanor.

Added Stats 1975 ch 678 § 70.

**CHAPTER 9****Towing**

## Section

12110. Acceptance of gift or compensation from towing service; Referral fees from repair shop

**§ 12110. Acceptance of gift or compensation from towing service; Referral fees from repair shop**

(a) Except as provided in subdivision (b), no towing service shall provide and no person or public entity shall accept any direct or indirect commission, gift, or any compensation whatever from a towing service in consid-

eration of arranging or requesting the services of a tow truck. As used in this section, "arranging" does not include the activities of employees or principals of a provider of towing services in responding to a request for towing services.

(b) Subdivision (a) does not preclude a public entity otherwise authorized by law from requiring a fee in connection with the award of a franchise for towing vehicles on behalf of that public entity. However, the fee in those cases may not exceed the amount necessary to reimburse the public entity for its actual and reasonable costs incurred in connection with the towing program.

(c) Any towing service or any employee of a towing service that accepts or agrees to accept any money or anything of value from a repair shop and any repair shop or any employee of a repair shop that pays or agrees to pay any money or anything of value as a commission, referral fee, inducement, or in any manner a consideration, for the delivery or the arranging of a delivery of a vehicle, not owned by the repair shop or towing service, for the purpose of storage or repair, is guilty of a misdemeanor, punishable as set forth in subdivision (d). Nothing in this subdivision prevents a towing service from towing a vehicle to a repair shop owned by the same company that owns the towing service.

(d) Any person convicted of a violation of subdivision (a) or (c) shall be punished as follows:

(1) Upon first conviction, by a fine of not more than five thousand dollars (\$5,000) or imprisonment in the county jail for not more than six months, or by both that fine and imprisonment. If the violation of subdivision (a) or (c) is committed by a tow truck driver, the person's privilege to operate a motor vehicle shall be suspended by the department under Section 13351.85. The clerk of the court shall send a certified abstract of the conviction to the department. If the violation of either subdivision (a) or (c) is committed by a tow truck driver, the court may order the impoundment of the tow truck involved for not more than 15 days.

(2) Upon a conviction of a violation of subdivision (a) or (c) that occurred within seven years of one or more separate convictions of violations of subdivision (a) or (c), by a fine of not more than ten thousand dollars (\$10,000) or imprisonment in the county jail for not more than one year, or by both that fine and imprisonment. If the violation of subdivision (a) or (c) is committed by a tow truck driver, the person's privilege to operate a motor vehicle shall be suspended by the department under Section 13351.85. The clerk of the court shall send a certified abstract of the conviction to the department. If the violation of either subdivision (a) or (c) is committed by a tow truck owner, the court may order the impoundment of the tow truck involved for not less than 15 days but not more than 30 days.

Added Stats 1983 ch 746 § 1. Amended Stats 1988 ch 924 § 5; Stats 1994 ch 268 § 1 (AB 3017), ch 675 § 4 (SB 1741). Amended Stats 2000 ch 641 § 1 (AB 2729).

**DIVISION 6**

**Drivers' Licenses**

**CHAPTER 2**

**Suspension or Revocation of Licenses**

**ARTICLE 3**

**Suspension and Revocation by Department**

Section  
13351.85. Suspension for conviction of towing service violation

**§ 13351.85. Suspension for conviction of towing service violation**

Upon receipt of a duly certified abstract of any court showing that a person has been convicted of a violation of Section 12110, the department shall suspend that person's driving privilege for four months if the conviction was a first conviction, and for one year, if the conviction was a second or subsequent conviction of a violation of that section that occurred within seven years of the current conviction.

Added Stats 2000 ch 641 § 2 (AB 2729).

**CHAPTER 4**

**Violation of License Provisions**

Section  
14607.6. Forfeiture of motor vehicle driven by driver with suspended or revoked license, or by unlicensed driver

**§ 14607.6. Forfeiture of motor vehicle driven by driver with suspended or revoked license, or by unlicensed driver**

(a) Notwithstanding any other provision of law, and except as provided in this section, a motor vehicle is subject to forfeiture as a nuisance if it is driven on a highway in this state by a driver with a suspended or revoked license, or by an unlicensed driver, who is a registered owner of the vehicle at the time of impoundment and has a previous misdemeanor conviction for a violation of subdivision (a) of Section 12500 or Section 14601, 14601.1, 14601.2, 14601.3, 14601.4, or 14601.5.

(b) A peace officer shall not stop a vehicle for the sole reason of determining whether the driver is properly licensed.

(c)(1) If a driver is unable to produce a valid driver's license on the demand of a peace officer enforcing the provisions of this code, as required by subdivision (b) of Section 12951, the vehicle shall be impounded regardless of ownership, unless the peace officer is reasonably able, by other means, to verify that the driver is properly licensed. Prior to impounding a vehicle, a peace officer shall attempt to verify the license status of a driver who claims to be properly licensed but is unable to produce the license on demand of the peace officer.

(2) A peace officer shall not impound a vehicle pursuant to this subdivision if the license of the driver expired within the preceding 30 days and the driver would otherwise have been properly licensed.

(3) A peace officer may exercise discretion in a situation where the driver without a valid license is an employee driving a vehicle registered to the employer in the course of employment. A peace officer may also exercise discretion in a situation where the driver without a valid license is the employee of a bona fide business establishment or is a person otherwise controlled by such an establishment and it reasonably appears that an owner of the vehicle, or an agent of the owner, relinquished possession of the vehicle to the business establishment solely for servicing or parking of the vehicle or other reasonably similar situations, and where the vehicle was not to be driven except as directly necessary to accomplish that business purpose. In this event, if the vehicle can be returned to or be retrieved by the business establishment or registered owner, the peace officer may release and not impound the vehicle.

(4) A registered or legal owner of record at the time of impoundment may request a hearing to determine the validity of the impoundment pursuant to subdivision (n).

(5) If the driver of a vehicle impounded pursuant to this subdivision was not a registered owner of the vehicle at the time of impoundment, or if the driver of the vehicle was a registered owner of the vehicle at the time of impoundment but the driver does not have a previous conviction for a violation of subdivision (a) of Section 12500 or Section 14601, 14601.1, 14601.2, 14601.3, 14601.4, or 14601.5, the vehicle shall be released pursuant to this code and is not subject to forfeiture.

(d)(1) This subdivision applies only if the driver of the vehicle is a registered owner of the vehicle at the time of impoundment. Except as provided in paragraph (5) of subdivision (c), if the driver of a vehicle impounded pursuant to subdivision (c) was a registered owner of the vehicle at the time of impoundment, the impounding agency shall authorize release of the vehicle if, within three days of impoundment, the driver of the vehicle at the time of impoundment presents his or her valid driver's license, including a valid temporary California driver's license or permit, to the impounding agency. The vehicle shall then be released to a registered owner of record at the time of impoundment, or an agent of that owner authorized in writing, upon payment of towing and storage charges related to the impoundment, and any administrative charges authorized by Section 22850.5, providing that the person claiming the vehicle is properly licensed and the vehicle is properly registered. A vehicle impounded pursuant to the circumstances described in paragraph (3) of subdivision (c) shall be released to a registered owner whether or not the driver of the vehicle at the time of impoundment presents a valid driver's license.

(2) If there is a community property interest in the vehicle impounded pursuant to subdivision (c), owned at the time of impoundment by a person other than the

driver, and the vehicle is the only vehicle available to the driver's immediate family that may be operated with a class C driver's license, the vehicle shall be released to a registered owner or to the community property interest owner upon compliance with all of the following requirements:

(A) The registered owner or the community property interest owner requests release of the vehicle and the owner of the community property interest submits proof of that interest.

(B) The registered owner or the community property interest owner submits proof that he or she, or an authorized driver, is properly licensed and that the impounded vehicle is properly registered pursuant to this code.

(C) All towing and storage charges related to the impoundment and any administrative charges authorized pursuant to Section 22850.5 are paid.

(D) The registered owner or the community property interest owner signs a stipulated vehicle release agreement, as described in paragraph (3), in consideration for the nonforfeiture of the vehicle. This requirement applies only if the driver requests release of the vehicle.

(3) A stipulated vehicle release agreement shall provide for the consent of the signator to the automatic future forfeiture and transfer of title to the state of any vehicle registered to that person, if the vehicle is driven by a driver with a suspended or revoked license, or by an unlicensed driver. The agreement shall be in effect for only as long as it is noted on a driving record maintained by the department pursuant to Section 1806.1.

(4) The stipulated vehicle release agreement described in paragraph (3) shall be reported by the impounding agency to the department not later than 10 days after the day the agreement is signed.

(5) No vehicle shall be released pursuant to paragraph (2) if the driving record of a registered owner indicates that a prior stipulated vehicle release agreement was signed by that person.

(e)(1) The impounding agency, in the case of a vehicle that has not been redeemed pursuant to subdivision (d), or that has not been otherwise released, shall promptly ascertain from the department the names and addresses of all legal and registered owners of the vehicle.

(2) The impounding agency, within two days of impoundment, shall send a notice by certified mail, return receipt requested, to all legal and registered owners of the vehicle, at the addresses obtained from the department, informing them that the vehicle is subject to forfeiture and will be sold or otherwise disposed of pursuant to this section. The notice shall also include instructions for filing a claim with the district attorney, and the time limits for filing a claim. The notice shall also inform any legal owner of its right to conduct the sale pursuant to subdivision (g). If a registered owner was personally served at the time of impoundment with a notice containing all the information required to be provided by this paragraph, no further notice is required to be sent to a registered owner. However, a notice shall still be sent to the legal owners of the vehicle, if any. If notice was not sent to the legal owner within two working days, the impounding agency shall not charge the legal owner for more than 15-days' impoundment when the legal owner redeems the impounded vehicle.

(3) No processing charges shall be imposed on a legal owner who redeems an impounded vehicle within 15 days of the impoundment of that vehicle. If no claims are filed and served within 15 days after the mailing of the notice in paragraph (2), or if no claims are filed and served within five days of personal service of the notice specified in paragraph (2), when no other mailed notice is required pursuant to paragraph (2), the district attorney shall prepare a written declaration of forfeiture of the vehicle to the state. A written declaration of forfeiture signed by the district attorney under this subdivision shall be deemed to provide good and sufficient title to the forfeited vehicle. A copy of the declaration shall be provided on request to any person informed of the pending forfeiture pursuant to paragraph (2). A claim that is filed and is later withdrawn by the claimant shall be deemed not to have been filed.

(4) If a claim is timely filed and served, then the district attorney shall file a petition of forfeiture with the appropriate juvenile or superior court within 10 days of the receipt of the claim. The district attorney shall establish an expedited hearing date in accordance with instructions from the court, and the court shall hear the matter without delay. The court filing fee of one hundred dollars (\$100) shall be paid by the claimant, but shall be reimbursed by the impounding agency if the claimant prevails. To the extent practicable, the civil and criminal cases shall be heard at the same time in an expedited, consolidated proceeding. A proceeding in the civil case is a limited civil case.

(5) The burden of proof in the civil case shall be on the prosecuting agency, by a preponderance of the evidence. All questions that may arise shall be decided and all other proceedings shall be conducted as in an ordinary civil action. A judgment of forfeiture does not require as a condition precedent the conviction of a defendant of an offense which made the vehicle subject to forfeiture. The filing of a claim within the time limits specified in paragraph (3) is considered a jurisdictional prerequisite for the availing of the action authorized by that paragraph.

(6) All right, title, and interest in the vehicle shall vest in the state upon commission of the act giving rise to the forfeiture.

(7) The filing fee in paragraph (4) shall be distributed as follows:

(A) To the county law library fund as provided in Section 6320 of the Business and Professions Code, the amount specified in Sections 6321 and 6322.1 of the Business and Professions Code.

(B) To the Trial Court Trust Fund, the remainder of the fee.

(f) Any vehicle impounded that is not redeemed pursuant to subdivision (d) and is subsequently forfeited pursuant to this section shall be sold once an order of forfeiture is issued by the district attorney of the county of the impounding agency or a court, as the case may be, pursuant to subdivision (e).

(g) Any legal owner who is a motor vehicle dealer, bank, credit union, acceptance corporation, or other licensed financial institution legally operating in this state, or the agent of that legal owner, may take possession and conduct the sale of the forfeited vehicle if the legal owner or agent notifies the agency impounding the

vehicle of its intent to conduct the sale within 15 days of the mailing of the notice pursuant to subdivision (e). Sale of the vehicle after forfeiture pursuant to this subdivision may be conducted at the time, in the manner, and on the notice usually given for the sale of repossessed or surrendered vehicles. The proceeds of any sale conducted by or on behalf of the legal owner shall be disposed of as provided in subdivision (i). A notice pursuant to this subdivision may be presented in person, by certified mail, by facsimile transmission, or by electronic mail.

(h) If the legal owner or agent of the owner does not notify the agency impounding the vehicle of its intent to conduct the sale as provided in subdivision (g), the agency shall offer the forfeited vehicle for sale at public auction within 60 days of receiving title to the vehicle. Low value vehicles shall be disposed of pursuant to subdivision (k).

(i) The proceeds of a sale of a forfeited vehicle shall be disposed of in the following priority:

(1) To satisfy the towing and storage costs following impoundment, the costs of providing notice pursuant to subdivision (e), the costs of sale, and the unfunded costs of judicial proceedings, if any.

(2) To the legal owner in an amount to satisfy the indebtedness owed to the legal owner remaining as of the date of sale, including accrued interest or finance charges and delinquency charges, providing that the principal indebtedness was incurred prior to the date of impoundment.

(3) To the holder of any subordinate lien or encumbrance on the vehicle, other than a registered or legal owner, to satisfy any indebtedness so secured if written notification of demand is received before distribution of the proceeds is completed. The holder of a subordinate lien or encumbrance, if requested, shall furnish reasonable proof of its interest and, unless it does so upon request, is not entitled to distribution pursuant to this paragraph.

(4) To any other person, other than a registered or legal owner, who can reasonably establish an interest in the vehicle, including a community property interest, to the extent of his or her provable interest, if written notification is received before distribution of the proceeds is completed.

(5) Of the remaining proceeds, funds shall be made available to pay any local agency and court costs, that are reasonably related to the implementation of this section, that remain unsatisfied.

(6) Of the remaining proceeds, half shall be transferred to the Controller for deposit in the Vehicle Inspection and Repair Fund for the high-polluter repair assistance and removal program created by Article 9 (commencing with Section 44090) of Chapter 5 of Part 5 of Division 26 of the Health and Safety Code, and half shall be transferred to the general fund of the city or county of the impounding agency, or the city or county where the impoundment occurred. A portion of the local funds may be used to establish a reward fund for persons coming forward with information leading to the arrest and conviction of hit-and-run drivers and to publicize the availability of the reward fund.

(j) The person conducting the sale shall disburse the proceeds of the sale as provided in subdivision (i) and shall provide a written accounting regarding the dispo-

sition to the impounding agency and, on request, to any person entitled to or claiming a share of the proceeds, within 15 days after the sale is conducted.

(k) If the vehicle to be sold pursuant to this section is not of the type that can readily be sold to the public generally, the vehicle shall be conveyed to a licensed dismantler or donated to an eleemosynary institution. License plates shall be removed from any vehicle conveyed to a dismantler pursuant to this subdivision.

(l) No vehicle shall be sold pursuant to this section if the impounding agency determines the vehicle to have been stolen. In this event, the vehicle may be claimed by the registered owner at any time after impoundment, providing the vehicle registration is current and the registered owner has no outstanding traffic violations or parking penalties on his or her driving record or on the registration record of any vehicle registered to the person. If the identity of the legal and registered owners of the vehicle cannot be reasonably ascertained, the vehicle may be sold.

(m) Any owner of a vehicle who suffers any loss due to the impoundment or forfeiture of any vehicle pursuant to this section may recover the amount of the loss from the unlicensed, suspended, or revoked driver. If possession of a vehicle has been tendered to a business establishment in good faith, and an unlicensed driver employed or otherwise directed by the business establishment is the cause of the impoundment of the vehicle, a registered owner of the impounded vehicle may recover damages for the loss of use of the vehicle from the business establishment.

(n)(1) The impounding agency, if requested to do so not later than 10 days after the date the vehicle was impounded, shall provide the opportunity for a poststorage hearing to determine the validity of the storage to the persons who were the registered and legal owners of the vehicle at the time of impoundment, except that the hearing shall be requested within three days after the date the vehicle was impounded if personal service was provided to a registered owner pursuant to paragraph (2) of subdivision (e) and no mailed notice is required.

(2) The poststorage hearing shall be conducted not later than two days after the date it was requested. The impounding agency may authorize its own officer or employee to conduct the hearing if the hearing officer is not the same person who directed the storage of the vehicle. Failure of either the registered or legal owner to request a hearing as provided in paragraph (1) or to attend a scheduled hearing shall satisfy the poststorage hearing requirement.

(3) The agency employing the person who directed the storage is responsible for the costs incurred for towing and storage if it is determined that the driver at the time of impoundment had a valid driver's license.

(o) As used in this section, "days" means workdays not including weekends and holidays.

(p) Charges for towing and storage for any vehicle impounded pursuant to this section shall not exceed the normal towing and storage rates for other vehicle towing and storage conducted by the impounding agency in the normal course of business.

(q) The Judicial Council and the Department of Justice may prescribe standard forms and procedures for

implementation of this section to be used by all jurisdictions throughout the state.

(r) The impounding agency may act as the agent of the state in carrying out this section.

(s) No vehicle shall be impounded pursuant to this section if the driver has a valid license but the license is for a class of vehicle other than the vehicle operated by the driver.

(t) This section does not apply to vehicles subject to Sections 14608 and 14609, if there has been compliance with the procedures in those sections.

(u) As used in this section, "district attorney" includes a city attorney charged with the duty of prosecuting misdemeanor offenses.

(v) The agent of a legal owner acting pursuant to subdivision (g) shall be licensed, or exempt from licensure, pursuant to Chapter 11 (commencing with Section 7500) of Division 3 of the Business and Professions Code.

Added Stats 1994 ch 1133 § 12 (AB 3148). Amended Stats 1995 ch 404 § 4 (SB 240); Stats 1998 ch 582 § 6 (SB 117), ch 931 § 457 (SB 2139), effective September 28, 1998, operative until January 1, 1999, ch 931 § 457.5 (SB 2139), effective September 28, 1998, operative January 1, 1999; Stats 2005 ch 75 § 151 (AB 145), effective July 19, 2005, operative January 1, 2006.

### DIVISION 11

### Rules of the Road

#### CHAPTER 10

#### Removal of Parked and Abandoned Vehicles

#### ARTICLE 1

#### Authority to Remove Vehicles

Section 22651.07. Duties of person charging for towing or storage; Exception; Rights of vehicle owner or agent; Towing Fees and Access Notice; Contents of itemized invoice; Violations

#### § 22651.07. Duties of person charging for towing or storage; Exception; Rights of vehicle owner or agent; Towing Fees and Access Notice; Contents of itemized invoice; Violations

(a) A person that charges for towing or storage, or both, except for storage unrelated to a tow, shall do all of the following:

(1)(A) Except as provided in subparagraph (B), post in the office area of the storage facility, in plain view of the public, the Towing Fees and Access Notice and have copies readily available to the public.

(B) An automotive repair dealer, registered pursuant to Article 3 (commencing with Section 9884) of Chapter 20.3 of Division 3 of the Business and Professions Code, that does not provide towing services is exempt from the requirement to post the Towing Fees and Access Notice in the office area.

(2) Provide, upon request, a copy of the Towing Fees and Access Notice to any owner or operator of a towed or stored vehicle.

(3) Provide a distinct notice on an itemized invoice for any towing or storage, or both, charges stating: "Upon request, you are entitled to receive a copy of the Towing Fees and Access Notice." This notice shall be contained within a bordered text box, printed in no less than 10-point type.

(b) Prior to receiving payment for any towing, recovery, or storage-related fees, a person that charges for towing or storage, or both, shall provide an itemized invoice of actual charges to the vehicle owner or his or her agent. If an automotive repair dealer, registered

pursuant to Article 3 (commencing with Section 9884) of Chapter 20.3 of Division 3 of the Business and Professions Code, did not provide the tow, and passes along, from the tower to the consumer, any of the information required on the itemized invoice, pursuant to subdivision (e), the automotive repair dealer shall not be responsible for the accuracy of those items of information that remain unaltered.

(c) Prior to paying any towing, recovery, or storage-related fees, a vehicle owner or his or her agent shall have the right to all of the following:

(1) Receive his or her personal property, at no charge, during normal business hours. Normal business hours are Monday through Friday from 8:00 a.m. to 5:00 p.m., inclusive, except state holidays.

(2) Retrieve his or her vehicle during the first 72 hours of storage and not pay a lien fee.

(3) Request a copy of the Towing Fees and Access Notice.

(4) Be permitted to pay by cash or a valid bank credit card. Credit charges for towing and storage services shall comply with Section 1748.1 of the Civil Code. Law enforcement agencies may include the costs of providing for payment by credit when agreeing with a towing or storage provider on rates.

(d) The Towing Fees and Access Notice shall be a standardized document plainly printed in no less than 10-point type. A person may distribute the form using its own letterhead, but the language of the Towing Fees and Access Notice shall read as follows:

#### **Towing Fees and Access Notice**

Note: The following information is intended to serve as a general summary of some of the laws that provide vehicle owners certain rights when their vehicle is towed. It is not intended to summarize all of the laws that may be applicable nor is it intended to fully and completely state the entire law in any area listed. Please review the applicable California code for a definitive statement of the law in your particular situation.

#### **How much can a towing company charge?**

Rates for public tows and storage are generally established by an agreement between the law enforcement agency requesting the tow and the towing company (to confirm the approved rates, you may contact the law enforcement agency that initiated the tow; additionally, these rates are required to be posted at the storage facility).

Rates for private property tows and storage cannot exceed the approved rates for the law enforcement agency that has primary jurisdiction for the property from which the vehicle was removed or the towing company's approved CHP rate.

Rates for private property tows and storage cannot exceed the approved rates for the law enforcement agency that has primary jurisdiction for the property from which the vehicle was removed or the towing company's approved CHP rate.

**Where can you complain about a towing company?**

For public tows: Contact the law enforcement agency initiating the tow.

**Your rights if your vehicle is towed:**

Generally, prior to paying any towing and storage-related fees you have the right to:

- Receive an itemized invoice of actual charges.
- Receive your personal property, at no charge, during normal business hours.
- Retrieve your vehicle during the first 72 hours of storage and not pay a lien fee.
- Request a copy of the Towing Fees and Access Notice.
- Pay by cash or valid bank credit card.
- Inspect your vehicle or have your insurance carrier inspect your vehicle at the storage facility, at no charge, during normal business hours.

You have the right to have the vehicle released to you upon (1) payment of all towing and storage-related fees, (2) presentation of a valid photo identification, (3) presentation of reliable documentation showing that you are the owner of the vehicle or that the owner has authorized you to take possession of the vehicle, and (4), if applicable, presentation of any required police or law enforcement release documents.

Prior to your vehicle being repaired:

- You have the right to choose the repair facility and to have no repairs made to your vehicle unless you authorize them in writing.
- Any authorization you sign for towing and any authorization you sign for repair must be on separate forms.

**What if I do not pay the towing and storage-related fees or abandon my vehicle at the towing company?**

Pursuant to Sections 3068.1 to 3074, inclusive, of the Civil Code, a towing company may sell your vehicle and any moneys received will be applied to towing and storage-related fees that have accumulated against your vehicle.

You are responsible for paying the towing company any outstanding balance due on any of these fees once the sale is complete.

**Who is liable if my vehicle was damaged during towing or storage?**

Generally the owner of a vehicle may recover for any damage to the vehicle resulting from any intentional or negligent act of a person causing the removal of, or removing, the vehicle.

**What happens if a towing company violates the law?**

If a tow company does not satisfactorily meet certain requirements detailed in this notice, you may bring a lawsuit in court, generally in small claims court. The tower may be civilly liable for damages up to two times the amount charged, not to exceed \$500, and possibly more for certain violations.

(e) "Itemized invoice," as used in this section, means a written document that contains the following information. Any document that substantially complies with this subdivision shall be deemed an "itemized invoice" for purposes of this section:

(1) The name, address, telephone number, and carrier identification number as required by subdivision (a) of Section 34507.5 of the person that is charging for towing and storage.

(2) If ascertainable, the registered owner or operator's name, address, and telephone number.

(3) The date service was initiated.

(4) The location of the vehicle at the time service was initiated, including either the address or nearest intersecting roadways.

(5) A vehicle description that includes, if ascertainable, the vehicle year, make, model, odometer reading, license plate number, or if a license plate number is unavailable, the vehicle identification number (VIN).

(6) The service dispatch time, the service arrival time of the tow truck, and the service completion time.

(7) A clear, itemized, and detailed explanation of any additional services that caused the total towing-related service time to exceed one hour between service dispatch time and service completion time.

(8) The hourly rate or per item rate used to calculate the total towing and recovery-related fees. These fees shall be listed as separate line items.

(9) If subject to storage fees, the daily storage rate and the total number of days stored. The storage fees shall be listed as a separate line item.

(10) If subject to a gate fee, the date and time the vehicle was either accessed, for the purposes of returning personal property, or was released after normal business

hours. Normal business hours are Monday through Friday from 8:00 a.m. to 5:00 p.m., inclusive, except state holidays. A gate fee shall be listed as a separate line item.

(11) A description of the method of towing.

(12) If the tow was not requested by the vehicle's owner or driver, the identity of the person or governmental agency that directed the tow. This paragraph shall not apply to information otherwise required to be redacted under Section 22658.

(13) A clear, itemized, and detailed explanation of any additional services or fees.

(f) "Person," as used in this section, has the same meaning as described in Section 470.

(g) An insurer or insurer's agent shall be permitted to pay for towing and storage charges by bank draft.

(h) A person who violates this section is civilly liable to a registered or legal owner of the vehicle, or a registered owner's insurer, for up to two times the amount charged. For any action brought under this section, liability shall not exceed five hundred dollars (\$500) per vehicle.

(i) This section shall not apply to the towing or storage of a repossessed vehicle by any person subject to, or exempt from, the Collateral Recovery Act (Chapter 11 (commencing with Section 7500) of Division 3 of the Business and Professions Code).

(j) This section does not relieve a person from the obligation to comply with the provision of any other law.

Added Stats 2010 ch 566 § 2 (AB 519), effective January 1, 2011.

## DIVISION 12

### Equipment of Vehicles

#### CHAPTER 1

#### General Provisions

##### Section

24000. References to "department"

24001. Applicability of provisions

24003. Operation of vehicle with unlawful lights

24004. Unlawful operation after notice by officer

24005. Sale, transfer or installation of unlawful equipment

24005.5. Uncertified synthetic rope or webbing strap material

24006. Equipment to bear name or trademark; Instructions regarding lighting equipment

24007. Responsibilities of dealer or retail seller of vehicle; Exemptions; Certificate of compliance or noncompliance or statement

24007.2. Exhaust emission devices; Free installation for low-income elderly persons

24007.5. Responsibility of auctioneer or public agency selling at public auction

24007.6. Responsibilities of salvage pool

24011.7. Exhaust and noise emission control inspection

24012. Compliance with lighting equipment and mounting regulations

##### § 24000. References to "department"

Wherever in his division the word "department" occurs, it means the Department of the California Highway Patrol.

Enacted Stats 1959 ch 3.

##### § 24001. Applicability of provisions

This division and Division 13 (commencing at Section 29000), unless otherwise provided applies to all vehicles whether publicly or privately owned when upon the highways, including all authorized emergency vehicles.

Enacted Stats 1959 ch 3. Amended Stats 1959 ch 1996 § 29.

##### § 24003. Operation of vehicle with unlawful lights

No vehicle shall be equipped with any lamp or illuminating device not required or permitted in this code, nor shall any lamp or illuminating device be mounted inside a vehicle unless specifically permitted by this code. This section does not apply to:

(a) Interior lamps such as door, brake and instrument lamps, and map, dash, and dome lamps designed and used for the purpose of illuminating the interior of the vehicle.

(b) Lamps needed in the operation or utilization of those vehicles mentioned in Section 25801, or vehicles used by public utilities in the repair or maintenance of their service, or used only for the illumination of cargo space of a vehicle while loading or unloading.

(c) Warning lamps mounted inside an authorized emergency vehicle and meeting requirements established by the department.

Enacted Stats 1959 ch 3. Amended Stats 1963 ch 547 § 1; Stats 1979 ch 723 § 1.

##### § 24004. Unlawful operation after notice by officer

No person shall operate any vehicle or combination of vehicles after notice by a peace officer, as defined in Section 830.1 or subdivision (a) of Section 830.2 of the Penal Code, that the vehicle is in an unsafe condition or is not equipped as required by this code, except as may be necessary to return the vehicle or combination of vehicles to the residence or place of business of the owner or driver or to a garage, until the vehicle and its equipment have been made to conform with the requirements of this code.

The provisions of this section shall not apply to an employee who does not know that such notice has been issued, and in such event the provisions of Section 40001 shall be applicable.

Enacted Stats 1959 ch 3. Amended Stats 1965 ch 306 § 1; Stats 1979 ch 171 § 2.

##### § 24005. Sale, transfer or installation of unlawful equipment

It is unlawful for any person to sell, offer for sale, lease, install, or replace, either for himself or as the agent or employee of another, or through such agent or employee, any glass, lighting equipment, signal devices, brakes, vacuum or pressure hose, muffler, exhaust, or any kind of equipment whatsoever for use, or with knowledge that any such equipment is intended for eventual use, in any vehicle, that is not in conformity with this code or regulations made thereunder.

Enacted Stats 1959 ch 3. Amended Stats 1961 ch 226 § 1; Stats 1971 ch 734 § 1.

**§ 24005.5. Uncertified synthetic rope or webbing strap material**

It is unlawful for any person to sell or offer for sale for use on loads regulated by the department any type of synthetic fiber rope or webbing strap material unless it meets requirements established by the department.

Added Stats 1972 ch 466 § 1. Amended Stats 1979 ch 723 § 8.

**§ 24006. Equipment to bear name or trademark; Instructions regarding lighting equipment**

No person shall sell or offer for sale either separately or as a part of the equipment of a new motor vehicle any equipment or device subject to requirements established by the department unless the equipment or device bears thereon the trademark or name and type or model designation under requirements established by the department and is accompanied by any printed instructions which may be required by the department as to the light source to be used with lamps, any particular methods of mounting or adjustment of lamps or other devices, and any other instructions as determined by the department necessary for compliance with this code.

Enacted Stats 1959 ch 3. Amended Stats 1967 ch 440 § 1, effective June 30, 1967; Stats 1979 ch 723 § 9.

**§ 24007. Responsibilities of dealer or retail seller of vehicle; Exemptions; Certificate of compliance or noncompliance or statement**

(a)(1) No dealer or person holding a retail seller's permit shall sell a new or used vehicle that is not in compliance with this code and departmental regulations adopted pursuant to this code, unless the vehicle is sold to another dealer, sold for the purpose of being legally wrecked or dismantled, or sold exclusively for off-highway use.

(2) Paragraph (1) does not apply to any vehicle sold by either (A) a dismantler after being reported for dismantling pursuant to Section 11520 or (B) a salvage pool after obtaining a salvage certificate pursuant to Section 11515 or a nonrepairable vehicle certificate issued pursuant to Section 11515.2.

(3) Notwithstanding paragraph (1), the equipment requirements of this division do not apply to the sale of a leased vehicle by a dealer to a lessee if the lessee is in possession of the vehicle immediately prior to the time of the sale and the vehicle is registered in this state.

(b)(1) Except as provided in Section 24007.5, no person shall sell, or offer or deliver for sale, to the ultimate purchaser, or to any subsequent purchaser a new or used motor vehicle, as those terms are defined in Chapter 2 (commencing with Section 39010) of Part 1 of Division 26 of the Health and Safety Code, subject to Part 5 (commencing with Section 43000) of that Division 26 which is not in compliance with that part and the rules and regulations of the State Air Resources Board, unless the vehicle is sold to a dealer or sold for the purpose of being legally wrecked or dismantled.

(2) Prior to or at the time of delivery for sale, the seller shall provide the purchaser a valid certificate of compliance or certificate of noncompliance, as appropriate, issued in accordance with Section 44015 of the Health and Safety Code.

(3) Paragraph (2) does not apply to any vehicle whose transfer of ownership and registration is described in subdivision (d) of Section 4000.1.

(4) Paragraphs (1) and (2) do not apply to any vehicle sold by either (A) a dismantler after being reported for dismantling pursuant to Section 11520 or (B) a salvage pool after obtaining a salvage certificate pursuant to Section 11515 or a nonrepairable vehicle certificate issued pursuant to Section 11515.2.

(c)(1) With each application for initial registration of a new motor vehicle or transfer of registration of a motor vehicle subject to Part 5 (commencing with Section 43000) of Division 26 of the Health and Safety Code, a dealer, the purchaser, or his or her authorized representative, shall transmit to the Department of Motor Vehicles a valid certificate of compliance or noncompliance, as appropriate, issued in accordance with Section 44015 of the Health and Safety Code.

(2) Notwithstanding paragraph (1) of this subdivision, with respect to new vehicles certified pursuant to Chapter 2 (commencing with Section 43100) of Part 5 of Division 26 of the Health and Safety Code, a dealer may transmit, in lieu of a certificate of compliance, a statement, in a form and containing information deemed necessary and appropriate by the Director of Motor Vehicles and the Executive Officer of the State Air Resources Board, to attest to the vehicle's compliance with that chapter. The statement shall be certified under penalty of perjury, and shall be signed by the dealer or the dealer's authorized representative.

(3) Paragraph (1) does not apply to a transfer of ownership and registration under any of the circumstances described in subdivision (d) of Section 4000.1.

Enacted Stats 1959 ch 3. Amended Stats 1965 ch 2031 § 11, effective July 23, 1965, ch 2033 § 1; Stats 1st Ex Sess 1966 ch 82 § 2; Stats 1967 ch 394 § 2; Stats 1968 ch 764 § 14; Stats 1970 ch 766 § 3; Stats 1971 ch 86 § 1, ch 1488 § 2; Stats 1972 ch 99 § 1, ch 268 § 2; Stats 1975 ch 957 § 29; Stats 1976 ch 1206 § 17; Stats 1977 ch 1038 § 5, effective September 23, 1977; Stats 1984 ch 246 § 6; Stats 1987 ch 1091 § 15; Stats 1988 ch 1268 § 18.5, ch 1544 § 61; Stats 1990 ch 1012 § 1 (SB 1876); Stats 1993 ch 958 § 3 (SB 575); Stats 1994 ch 1008 § 18 (SB 1833), operative July 1, 1995; Stats 1998 ch 517 § 2 (SB 559). Amended Stats 2004 ch 230 § 20 (SB 1107), effective August 16, 2004.

**§ 24007.2. Exhaust emission devices; Free installation for low-income elderly persons**

If a dealer, or a person holding a retail seller's permit, sells to an elderly low-income person, as defined in Section 39026.5 of the Health and Safety Code, a 1966 through 1970 model year motor vehicle which is not equipped, as required pursuant to Sections 43654 and 43656 of that code, with a certified device to control its exhaust emission of oxides of nitrogen, the dealer or such person, as the case may be, shall install the required certified device on the motor vehicle without cost to the elderly low-income person.

Added Stats 1976 ch 231 § 6.

**§ 24007.5. Responsibility of auctioneer or public agency selling at public auction**

(a)(1) No auctioneer or public agency shall sell, at public auction, any vehicle specified in subdivision (a) of Section 24007, which is not in compliance with this code.

(2) Paragraph (1) does not apply to a vehicle that is sold under the conditions specified in subdivision (c), (d), (e), or (g) or is sold to a dealer or for the purpose of being wrecked or dismantled or is sold exclusively for off-highway use.



(b) Except with respect to the sale of a vehicle specified in paragraph (2) of subdivision (a), the consignor of any vehicle, specified in subdivision (b) of Section 24007, sold at public auction, shall provide the purchaser a valid certificate of compliance or certificate of noncompliance, as appropriate, issued in accordance with Section 44015 of the Health and Safety Code.

(c) Notwithstanding any other provision of this code, if, in the opinion of a public utility or public agency, the cost of repairs to a vehicle exceeds the value of the vehicle to the public utility or public agency, the public utility or public agency shall, as transferee or owner, surrender the certificates of registration, documents satisfactory to the Department of Motor Vehicles showing proof of ownership, and the license plates issued for the vehicle to the Department of Motor Vehicles. As used in this section, "public utility" means a public utility as described in Sections 218, 222, and 234 of the Public Utilities Code.

(d) The public utility or public agency having complied with subdivision (c) shall, upon sale of the vehicle, give to the purchaser a bill of sale which includes, in addition to any other required information, the last issued license plate number.

(e)(1) Subdivisions (a) and (b) do not apply to any judicial sale, including, but not limited to, a bankruptcy sale, conducted pursuant to a writ of execution or order of court.

(2) Subdivision (b) does not apply to any lien sale if the lienholder does both of the following:

(A) Gives the notice required by subdivisions (a) and (b) of Section 5900.

(B) Notifies the buyer that California law requires that the buyer obtain a certificate of compliance or noncompliance and register the vehicle with the department, and that failure to comply will result in a lien against any vehicle owned by the buyer pursuant to Section 10876 of the Revenue and Taxation Code, enforceable pursuant to Section 10877 of the Revenue and Taxation Code and Article 6 (commencing with Section 9800) of Chapter 6 of Division 3. Receipt of the notice required by this subparagraph shall be evidenced by the signature of the buyer.

(f) The exceptions in this section do not apply to any requirements for registration of a vehicle pursuant to Section 4000.1, 4000.2, or 4000.3.

(g) Except as otherwise provided in subdivision (e), any public agency or auctioneer which sells, at public auction, any vehicle specified in subdivision (b) of Section 24007, which is registered to a public agency or a public utility, shall provide each bidder with a notice in writing that a certificate of compliance is required to be obtained, certifying that the vehicle complies with Part 5 (commencing with Section 43000) of Division 26 of the Health and Safety Code, before the vehicle may be registered in this state, unless the vehicle is sold to a dealer or for the purpose of being wrecked or dismantled or is sold exclusively for off-highway use. Prior to the sale of the vehicle, a public agency or public utility shall remove the license plates from the vehicle and surrender them to the department. The purchaser of the vehicle shall be given a bill of sale which includes, in addition to any other

required information, the vehicle's last issued license plate number.

Added Stats 1971 ch 1021 § 1. Amended Stats 1975 ch 957 § 30; Stats 1987 ch 1091 § 16; Stats 1991 ch 1054 § 5 (SB 245); Stats 1992 ch 427 § 167 (AB 3355).

#### § 24007.6. Responsibilities of salvage pool

Except for vehicles sold to a dealer or for the purpose of being wrecked or dismantled or sold exclusively for off-highway use, a salvage pool shall do both of the following:

(a) Give the notice required by subdivisions (a) and (b) of Section 5900.

(b) Notify the buyer that California law requires that the buyer obtain a certificate of compliance or noncompliance and to register the vehicle with the department, and that failure to comply will result in a lien against any vehicle owned by the buyer pursuant to Section 10876 of the Revenue and Taxation Code, enforceable pursuant to Section 10877 of the Revenue and Taxation Code and Article 6 (commencing with Section 9800) of Chapter 6 of Division 3. Receipt of the notice required by this paragraph shall be evidenced by the signature of the buyer.

Added Stats 1991 ch 996 § 4 (SB 798).

#### § 24011.7. Exhaust and noise emission control inspection

(a) Nothing in Chapter 20.4 (commencing with Section 9889.50) of Division 3 of the Business and Professions Code, shall be construed as having any effect on the existing inspection program conducted by the department. Rather, it is the intent of the Legislature that such program continue and that a cooperative relationship between the department and the Department of Consumer Affairs be established, under which the department can inform the Department of Consumer Affairs of the results and experiences of the department in order to provide data on exhaust and noise emission control device tampering and performance deterioration following mandatory inspections.

Added Stats 1973 ch 1154 § 5.

#### § 24012. Compliance with lighting equipment and mounting regulations

All lighting equipment or devices subject to requirements established by the department shall comply with the engineering requirements and specifications, including mounting and aiming instructions, determined and publicized by the department.

Enacted Stats 1959 ch 3, as Veh C § 25953. Renumbered by Stats 1969 ch 341 § 7. Amended Stats 1979 ch 723 § 10.

## CHAPTER 2

### Lighting Equipment

#### ARTICLE 1

### General Provisions

Section  
24250. Use of lights during darkness  
24251. Lighting distance requirement

Section

- 24252. Lighting equipment requirements
- 24253. Taillamps that remain lighted
- 24254. Mounting height
- 24255. Supplementary illuminating system

**§ 24250. Use of lights during darkness**

During darkness, a vehicle shall be equipped with lighted lighting equipment as required for the vehicle by this chapter.

Enacted Stats 1959 ch 3.

**§ 24251. Lighting distance requirement**

Any requirement in this chapter as to the distance from which any lighting equipment shall render a person or vehicle visible or within which any lighting equipment shall be visible shall apply during darkness, directly ahead upon a straight, level unlighted highway, and under normal atmospheric conditions, unless a different time, direction, or condition is expressly stated.

Enacted Stats 1959 ch 3.

**§ 24252. Lighting equipment requirements**

(a) All lighting equipment of a required type installed on a vehicle shall at all times be maintained in good working order. Lamps shall be equipped with bulbs of the correct voltage rating corresponding to the nominal voltage at the lamp socket.

(b) The voltage at any tail, stop, license plate, side marker or clearance lamp socket on a vehicle shall not be less than 85 percent of the design voltage of the bulb. Voltage tests shall be conducted with the engine operating.

(c) Two or more lamp or reflector functions may be combined, provided each function subject to requirements established by the department meets such requirements.

(1) No turn signal lamp may be combined optically with a stoplamp unless the stoplamp is extinguished when the turn signal is flashing.

(2) No clearance lamp may be combined optically with any taillamp or identification lamp.

Enacted Stats 1959 ch 3. Amended Stats 1965 ch 1276 § 1; Stats 1968 ch 980 § 2; Stats 1979 ch 723 § 11.

**§ 24253. Taillamps that remain lighted**

(a) All motor vehicles manufactured and first registered after January 1, 1970, shall be equipped so all taillamps are capable of remaining lighted for a period of at least one-quarter hour with the engine inoperative. This requirement shall be complied with by an energy storing system which is recharged by energy produced by the vehicle.

(b) All motorcycles manufactured and first registered after January 1, 1971, shall be equipped so all taillamps, when turned on, will remain lighted automatically for a period of at least one-quarter hour if the engine stops.

Added Stats 1967 ch 544 § 1. Amended Stats 1970 ch 217 § 1.

**§ 24254. Mounting height**

Whenever a requirement is declared as to the mounted height of lamps or reflectors, the height shall be measured from the center of the lamp or reflector to the level

surface upon which the vehicle stands when it is without a load.

Enacted Stats 1959 ch 3, as Veh C § 25952. Amended and renumbered by Stats 1969 ch 341 § 5.

**§ 24255. Supplementary illuminating system**

(a) A vehicle may be equipped with a system to supplement the driver's visibility of the roadway to the front or rear of the vehicle during darkness. This system may incorporate an illuminating device that emits radiation predominantly in the infrared region of the electromagnetic spectrum and a display monitor to provide an image visible to the driver of the vehicle. The system, or any portion of it, shall not obstruct the vision of the driver, and shall not emit any glaring light visible in any direction or to any person. The illuminating device may be mounted inside the vehicle, if it is constructed and mounted so as to prevent any direct or reflected light, other than a monitorial indicator emitted from the device, from being visible to the driver.

(b) The system shall be operated only with the headlamps lighted. An illuminating device for the system shall be interlocked with the headlamp switch so that it is operable only when the headlamps are lighted.

(c)(1) No part of the illuminating device may be physically or optically combined with any other required or permitted lighting device.

(2) The illuminating device may be installed within a housing containing other required or permitted lighting devices, if the function of the other devices is not impaired thereby.

Added Stats 2004 ch 198 § 2 (SB 1236).

**ARTICLE 2**

**Headlamps and Auxiliary Lamps**

Section

- 24400. Headlamps on motor vehicles; Use in darkness and inclement weather
- 24401. Dimmed lights on parked or standing vehicles
- 24402. Auxiliary driving and passing lamps
- 24403. Foglamps
- 24404. Spotlamps
- 24405. Maximum number of lamps
- 24406. Multiple beams
- 24407. Upper and lower beam
- 24408. Beam indicator
- 24409. Use of multiple beams
- 24410. Single beams
- 24411. Auxiliary lamps; Off-highway use

**§ 24400. Headlamps on motor vehicles; Use in darkness and inclement weather**

(a) A motor vehicle, other than a motorcycle, shall be equipped with at least two headlamps, with at least one on each side of the front of the vehicle, and, except as to vehicles registered prior to January 1, 1930, they shall be located directly above or in advance of the front axle of the vehicle. The headlamps and every light source in any headlamp unit shall be located at a height of not more than 54 inches nor less than 22 inches.

(b) A motor vehicle, other than a motorcycle, shall be operated during darkness, or inclement weather, or both, with at least two lighted headlamps that comply with subdivision (a).

(c) As used in subdivision (b), “inclement weather” is a weather condition that is either of the following:

(1) A condition that prevents a driver of a motor vehicle from clearly discerning a person or another motor vehicle on the highway from a distance of 1,000 feet.

(2) A condition requiring the windshield wipers to be in continuous use due to rain, mist, snow, fog, or other precipitation or atmospheric moisture.

Added Stats 2004 ch 415 § 2 (AB 1854), operative July 1, 2005. Amended Stats 2006 ch 311 § 9 (SB 1586), effective January 1, 2007; Stats 2010 ch 491 § 43 (SB 1318), effective January 1, 2011.

#### § 24401. Dimmed lights on parked or standing vehicles

Whenever any motor vehicle is parked or standing upon a highway any headlamp that is lighted shall be dimmed or on the lower beam.

Enacted Stats 1959 ch 3.

#### § 24402. Auxiliary driving and passing lamps

(a) Any motor vehicle may be equipped with not to exceed two auxiliary driving lamps mounted on the front at a height of not less than 16 inches nor more than 42 inches. Driving lamps are lamps designed for supplementing the upper beam from headlamps and may not be lighted with the lower beam.

(b) Any motor vehicle may be equipped with not to exceed two auxiliary passing lamps mounted on the front at a height of not less than 24 inches nor more than 42 inches. Passing lamps are lamps designed for supplementing the lower beam from headlamps and may also be lighted with the upper beam.

Enacted Stats 1959 ch 3.

#### § 24403. Foglamps

(a) A motor vehicle may be equipped with not more than two foglamps that may be used with, but may not be used in substitution of, headlamps.

(b) On a motor vehicle other than a motorcycle, the foglamps authorized under this section shall be mounted on the front at a height of not less than 12 inches nor more than 30 inches and aimed so that when the vehicle is not loaded none of the high-intensity portion of the light to the left of the center of the vehicle projects higher than a level of four inches below the level of the center of the lamp from which it comes, for a distance of 25 feet in front of the vehicle.

(c) On a motorcycle, the foglamps authorized under this section shall be mounted on the front at a height of not less than 12 inches nor more than 40 inches and aimed so that when the vehicle is not loaded none of the high-intensity portion of the light to the left of the center of the vehicle projects higher than a level of four inches below the level of the center of the lamp from which it comes, for a distance of 25 feet in front of the vehicle.

Enacted Stats 1959 ch 3. Amended Stats 1961 ch 58 § 44, effective March 31, 1961; Stats 1969 ch 341 § 1. Amended Stats 2003 ch 451 § 20 (AB 1718).

#### § 24404. Spotlamps

(a) A motor vehicle may be equipped with not to exceed two white spotlamps, which shall not be used in substitution of headlamps.

(b) No spotlamp shall be equipped with any lamp source exceeding 32 standard candlepower or 30 watts nor project any glaring light into the eyes of an approaching driver.

(c) Every spotlamp shall be so directed when in use: That no portion of the main substantially parallel beam of light will strike the roadway to the left of the prolongation of the left side line of the vehicle.

That the top of the beam will not strike the roadway at a distance in excess of 300 feet from the vehicle.

(d) This section does not apply to spotlamps on authorized emergency vehicles.

(e) No spotlamp when in use shall be directed so as to illuminate any other moving vehicle.

Enacted Stats 1959 ch 3. Amended Stats 1959 ch 403 § 2, ch 1996 § 29.5; Stats 1967 ch 544 § 2.

#### § 24405. Maximum number of lamps

(a) Not more than four lamps of the following types showing to the front of a vehicle may be lighted at any one time:

- (1) Headlamps.
- (2) Auxiliary driving or passing lamps.
- (3) Fog lamps.
- (4) Warning lamps.
- (5) Spot lamps.
- (6) Gaseous discharge lamps specified in Section 25258.

(b) For the purpose of this section each pair of a dual headlamp system shall be considered as one lamp.

(c) Subdivision (a) does not apply to any authorized emergency vehicle.

Enacted Stats 1959 ch 3. Amended Stats 1963 ch 547 § 2; Stats 1965 ch 1313 § 2; Stats 1970 ch 174 § 1; Stats 1976 ch 234 § 1.

#### § 24406. Multiple beams

Except as otherwise provided, the headlamps, or other auxiliary driving lamps, or a combination thereof, on a motor vehicle during darkness shall be so arranged that the driver may select at will between distributions of light projected to different elevations, and the lamps may, in addition, be so arranged that the selection can be made automatically.

Enacted Stats 1959 ch 3.

#### § 24407. Upper and lower beam

Multiple-beam road lighting equipment shall be designed and aimed as follows:

(a) There shall be an uppermost distribution of light, or composite beam, so aimed and of such intensity as to reveal persons and vehicles at a distance of at least 350 feet ahead for all conditions of loading.

(b) There shall be a lowermost distribution of light, or composite beam so aimed and of sufficient intensity to reveal a person or vehicle at a distance of at least 100 feet ahead. On a straight level road under any condition of loading none of the high intensity portion of the beam shall be directed to strike the eyes of an approaching driver.

Enacted Stats 1959 ch 3. Amended Stats 1963 ch 547 § 3.

#### § 24408. Beam indicator

(a) Every new motor vehicle registered in this state after January 1, 1940, which has multiple-beam road

lighting equipment shall be equipped with a beam indicator, which shall be lighted whenever the uppermost distribution of light from the headlamps is in use, and shall not otherwise be lighted.

(b) The indicator shall be so designed and located that when lighted it will be readily visible without glare to the driver of the vehicle so equipped. Any such lamp on the exterior of the vehicle shall have a light source not exceeding two candlepower, and the light shall not show to the front or sides of the vehicle.

Enacted Stats 1959 ch 3. Amended Stats 1965 ch 1124 § 1; Stats 1970 ch 422 § 1.

**§ 24409. Use of multiple beams**

Whenever a motor vehicle is being operated during darkness, the driver shall use a distribution of light, or composite beam, directed high enough and of sufficient intensity to reveal persons and vehicles at a safe distance in advance of the vehicle, subject to the following requirements and limitations:

(a) Whenever the driver of a vehicle approaches an oncoming vehicle within 500 feet, he shall use a distribution of light or composite beam so aimed that the glaring rays are not projected into the eyes of the oncoming driver.

The lowermost distribution of light specified in this article shall be deemed to avoid glare at all times regardless of road contour.

(b) Whenever the driver of a vehicle follows another vehicle within 300 feet to the rear, he shall use the lowermost distribution of light specified in this article.

Enacted Stats 1959 ch 3. Amended Stats 1963 ch 547 § 4; Stats 1965 ch 37 § 1.

**§ 24410. Single beams**

Headlamps arranged to provide a single distribution of light not supplemented by auxiliary driving lamps are permitted on motor vehicles manufactured and sold prior to September 19, 1940, in lieu of multiple-beam road lighting equipment if the single distribution of light complies with the following requirements and limitations:

(a) The headlamps shall be so aimed that when the vehicle is not loaded none of the high-intensity portion of the light shall at a distance of 25 feet ahead project higher than a level of five inches below the level of the center of the lamp from which it comes, and in no case higher than 42 inches above the level on which the vehicle stands at a distance of 75 feet ahead.

(b) The intensity shall be sufficient to reveal persons and vehicles at a distance of at least 200 feet.

Enacted Stats 1959 ch 3.

**§ 24411. Auxiliary lamps; Off-highway use**

Notwithstanding any other provision of law, a vehicle may be equipped with not more than eight lamps for use as headlamps while the vehicle is operated or driven off the highway. The lamps shall be mounted at a height of not less than 16 inches from the ground, or more than 12 inches above the top of the passenger compartment, at any place between the front of the vehicle and a line lying on a point 40 inches to the rear of the seat occupied by the driver, shall be wired independently of all other lighting circuits, and, whenever the vehicle is operated

or driven upon a highway, shall be covered or hooded with an opaque hood or cover, and turned off.

Added Stats 1975 ch 860 § 1. Amended Stats 1979 ch 723 § 12; Stats 1980 ch 399 § 3, effective July 11, 1980; Stats 1986 ch 149 § 1.

**ARTICLE 3**

**Rear Lighting Equipment**

Section

- 24600. Taillamp requirements, generally
- 24601. License plate light
- 24602. Fog taillamps
- 24603. Stoplamp requirements
- 24604. Lamp or flag on load projections
- 24605. Tow trucks and towed vehicles
- 24606. Backup lamps
- 24607. Red reflector requirements
- 24608. Reflector requirements for buses, trailers, housecars, and motor-trucks
- 24609. Reflectors on front of vehicle
- 24610. Multiple-unit truck reflectors
- 24611. Exemption from reflector requirements for certain trailers
- 24615. Slow moving vehicle emblem
- 24616. Equipping vehicle with rear-facing auxiliary lamps

**§ 24600. Taillamp requirements, generally**

During darkness every motor vehicle which is not in combination with any other vehicle and every vehicle at the end of a combination of vehicles shall be equipped with lighted taillamps mounted on the rear as follows:

(a) Every vehicle shall be equipped with one or more taillamps.

(b) Every vehicle, other than a motorcycle, manufactured and first registered on or after January 1, 1958, shall be equipped with not less than two taillamps, except that trailers and semitrailers manufactured after July 23, 1973, which are less than 30 inches wide, may be equipped with one taillamp which shall be mounted at or near the vertical centerline of the vehicles. If a vehicle is equipped with two taillamps, they shall be mounted as specified in subdivision (d).

(c) Every vehicle or vehicle at the end of a combination of vehicles, subject to subdivision (a) of Section 22406 shall be equipped with not less than two taillamps.

(d) When two taillamps are required, at least one shall be mounted at the left and one at the right side respectively at the same level.

(e) Taillamps shall be red in color and shall be plainly visible from all distances within 500 feet to the rear except that taillamps on vehicles manufactured after January 1, 1969, shall be plainly visible from all distances within 1,000 feet to the rear.

(f) Taillamps on vehicles manufactured on or after January 1, 1969, shall be mounted not lower than 15 inches nor higher than 72 inches, except that a tow truck, in addition to being equipped with the required taillamps, may also be equipped with two taillamps which may be mounted not lower than 15 inches nor higher than the maximum allowable vehicle height and as far forward as the rearmost portion of the driver's seat in the rearmost position. The additional taillamps on a tow truck shall be lighted whenever the headlamps are lighted.

Added Stats 1968 ch 980 § 4. Amended Stats 1969 ch 341 § 2; Stats 1970 ch 923 § 5; Stats 1974 ch 635 § 2; Stats 1976 ch 154 § 2; Stats 1988 ch 924 § 11.

**§ 24601. License plate light**

Either the taillamp or a separate lamp shall be so constructed and placed as to illuminate with a white light the rear license plate during darkness and render it clearly legible from a distance of 50 feet to the rear. When the rear license plate is illuminated by a lamp other than a required taillamp, the two lamps shall be turned on or off only by the same control switch at all times.

Enacted Stats 1959 ch 3. Amended Stats 1965 ch 1313 § 4.

**§ 24602. Fog taillamps**

(a) A vehicle may be equipped with not more than two red fog taillamps mounted on the rear which may be lighted, in addition to the required taillamps, only when atmospheric conditions, such as fog, rain, snow, smoke, or dust, reduce the daytime or nighttime visibility of other vehicles to less than 500 feet.

(b) The lamps authorized under subdivision (a) shall be installed as follows:

(1) When two lamps are installed, one shall be mounted at the left side and one at the right side at the same level and as close as practical to the sides. When one lamp is installed, it shall be mounted as close as practical to the left side or on the center of the vehicle.

(2) The lamps shall be mounted not lower than 12 inches nor higher than 60 inches.

(3) The edge of the lens of the lamp shall be no closer than four inches from the edge of the lens of any stoplamp.

(4) The lamps shall be wired so they can be turned on only when the headlamps are on and shall have a switch that allows them to be turned off when the headlamps are on.

(5) A nonflashing amber pilot light that is lighted when the lamps are turned on shall be mounted in a location readily visible to the driver.

Added Stats 1977 ch 800 § 2, effective September 14, 1977. Amended Stats 1980 ch 350 § 1. Amended Stats 2004 ch 615 § 30 (SB 1233); Stats 2005 ch 270 § 11 (SB 731), effective January 1, 2006.

**§ 24603. Stoplamp requirements**

Every motor vehicle that is not in combination with any other vehicle and every vehicle at the end of a combination of vehicles shall at all times be equipped with stoplamps mounted on the rear as follows:

(a) Every such vehicle shall be equipped with one or more stoplamps.

(b) Every such vehicle, other than a motorcycle, manufactured and first registered on or after January 1, 1958, shall be equipped with two stoplamps, except that trailers and semitrailers manufactured after July 23, 1973, which are less than 30 inches wide, may be equipped with one stoplamp which shall be mounted at or near the vertical centerline of the trailer. If such vehicle is equipped with two stoplamps, they shall be mounted as specified in subdivision (d).

(c) Except as provided in subdivision (h), stoplamps on vehicles manufactured on or after January 1, 1969, shall be mounted not lower than 15 inches nor higher than 72 inches, except that a tow truck or a reposessor's tow vehicle, in addition to being equipped with the required stoplamps, may also be equipped with two stoplamps which may be mounted not lower than 15 inches nor

higher than the maximum allowable vehicle height and as far forward as the rearmost portion of the driver's seat in the rearmost position.

(d) Where two stoplamps are required, at least one shall be mounted at the left and one at the right side, respectively, at the same level.

(e) Stoplamps on vehicles manufactured on or after January 1, 1979, shall emit a red light. Stoplamps on vehicles manufactured before January 1, 1979, shall emit a red or yellow light. All stoplamps shall be plainly visible and understandable from a distance of 300 feet to the rear both during normal sunlight and at nighttime, except that stoplamps on a vehicle of a size required to be equipped with clearance lamps shall be visible from a distance of 500 feet during those times.

(f) Stoplamps shall be activated upon application of the service (foot) brake and the hand control head for air, vacuum, or electric brakes. In addition, all stoplamps may be activated by a mechanical device designed to function only upon sudden release of the accelerator while the vehicle is in motion. Stoplamps on vehicles equipped with a manual transmission may be manually activated by a mechanical device when the vehicle is downshifted if the device is automatically rendered inoperative while the vehicle is accelerating.

(g) Any vehicle may be equipped with supplemental stoplamps mounted to the rear of the rearmost portion of the driver's seat in its rearmost position in addition to the lamps required to be mounted on the rear of the vehicle. Supplemental stoplamps installed after January 1, 1979, shall be red in color and mounted not lower than 15 inches above the roadway. The supplemental stoplamp on that side of a vehicle toward which a turn will be made may flash as part of the supplemental turn signal lamp.

A supplemental stoplamp may be mounted inside the rear window of a vehicle, if it is mounted at the centerline of the vehicle and is constructed and mounted so as to prevent any light, other than a monitorial indicator emitted from the device, either direct or reflected, from being visible to the driver.

(h) Any supplemental stoplamp installed after January 1, 1987, shall comply with Federal Motor Vehicle Safety Standard No. 108 (49 C.F.R. 571.108). Any vehicle equipped with a stoplamp that complies with the federal motor vehicle safety standards applicable to that make and model vehicle shall conform to that applicable safety standard unless modified to comply with the federal motor vehicle safety standard designated in this subdivision.

Added Stats 1968 ch 980 § 7. Amended Stats 1969 ch 341 § 3; Stats 1973 ch 774 § 3, effective September 25, 1973; Stats 1974 ch 635 § 3; Stats 1976 ch 154 § 3; Stats 1977 ch 287 § 2; Stats 1978 ch 252 § 3, effective June 16, 1978; Stats 1979 ch 723 § 13; Stats 1981 ch 738 § 1; Stats 1984 ch 64 § 1; Stats 1986 ch 1184 § 1; Stats 1988 ch 924 § 12; Stats 2009 ch 307 § 108 (SB 821), effective January 1, 2010.

**§ 24604. Lamp or flag on load projections**

Whenever the load upon any vehicle extends, or whenever any integral part of any vehicle projects, to the rear four feet or more beyond the rear of the vehicle, as measured from the taillamps, there shall be displayed at the extreme end of the load or projecting part of the vehicle during darkness, in addition to the required

taillamp, two red lights with a bulb rated not in excess of six candlepower plainly visible from a distance of at least 500 feet to the sides and rear. At any other time there shall be displayed at the extreme end of the load or projecting part of the vehicle a solid red or fluorescent orange flag or cloth not less than 12 inches square.

Enacted Stats 1959 ch 3. Amended Stats 1959 ch 1996 § 31; Stats 1965 ch 1313 § 6; Stats 1998 ch 828 § 18 (SB 1637). Amended Stats 2000 ch 1035 § 28 (SB 1403).

**§ 24605. Tow trucks and towed vehicles**

(a) A tow truck or an automobile dismantler's tow vehicle used to tow a vehicle shall be equipped with and carry a taillamp, a stoplamp, and turn signal lamps for use on the rear of a towed vehicle.

(b) Whenever a tow truck or an automobile dismantler's tow vehicle is towing a vehicle and a stoplamp and turn signal lamps cannot be lighted and displayed on the rear of the towed vehicle, the operator of the tow truck or the automobile dismantler's tow vehicle shall display to the rear a stoplamp and turn signal lamps mounted on the towed vehicle, except as provided in subdivision (c). During darkness, if a taillamp on the towed vehicle cannot be lighted, the operator of the tow truck or the automobile dismantler's tow vehicle display to the rear a taillamp mounted on the towed vehicle. No other lighting equipment need be displayed on the towed vehicle.

(c) Whenever any motor vehicle is towing another motor vehicle, stoplamps and turn signal lamps are not required on the towed motor vehicle, but only if a stoplamp and a turn signal lamp on each side of the rear of the towing vehicle is plainly visible to the rear of the towed vehicle. This subdivision does not apply to drive-away-towaway operations.

Enacted Stats 1959 ch 3. Amended Stats 1961 ch 1933 § 1; Stats 1965 ch 34 § 1; Stats 1977 ch 287 § 3; Stats 1985 ch 710 § 3; Stats 1988 ch 924 § 13; Stats 2009 ch 322 § 12 (AB 515), effective January 1, 2010.

**§ 24606. Backup lamps**

(a) Every motor vehicle, other than a motorcycle, of a type subject to registration and manufactured on and after January 1, 1969, shall be equipped with one or more backup lamps either separately or in combination with another lamp. Any vehicle may be equipped with backup lamps.

(b) Backup lamps shall be so directed as to project a white light illuminating the highway to the rear of the vehicle for a distance not to exceed 75 feet. A backup lamp may project incidental red, amber, or white light through reflectors or lenses that are adjacent or close to, or a part of, the lamp assembly.

(c) Backup lamps shall not be lighted except when the vehicle is about to be or is backing or except in conjunction with a lighting system which activates the lights for a temporary period after the ignition system is turned off.

(d) Any motor vehicle may be equipped with a lamp emitting white light on each side near or on the rear of the vehicle which is designed to provide supplemental illumination in an area to the side and rear not lighted by the backup lamps. These lamps shall be lighted only with the backup lamps.

Enacted Stats 1959 ch 3. Amended Stats 1961 ch 159 § 2; Stats 1965 ch 315 § 1; Stats 1967 ch 544 § 3; Stats 1968 ch 980 § 8; Stats 1981 ch 813 § 17.

**§ 24607. Red reflector requirements**

Every vehicle subject to registration under this code shall at all times be equipped with red reflectors mounted on the rear as follows:

(a) Every vehicle shall be equipped with at least one reflector so maintained as to be plainly visible at night from all distances within 350 to 100 feet from the vehicle when directly in front of the lawful upper headlamp beams.

(b) Every vehicle, other than a motorcycle or a low-speed vehicle, manufactured and first registered on or after January 1, 1965, shall be equipped with at least two reflectors meeting the visibility requirements of subdivision (a), except that trailers and semitrailers manufactured after July 23, 1973, that are less than 30 inches wide, may be equipped with one reflector which shall be mounted at or near the vertical centerline of the trailer. If the vehicle is equipped with two reflectors, they shall be mounted as specified in subdivision (d).

(c) Every motortruck having an unladen weight of more than 5,000 pounds, every trailer coach, every camp trailer, every vehicle, or vehicle at the end of a combination of vehicles, subject to subdivision (a) of Section 22406, and every vehicle 80 or more inches in width manufactured on or after January 1, 1969, shall be equipped with at least two reflectors maintained so as to be plainly visible at night from all distances within 600 feet to 100 feet from the vehicle when directly in front of lawful upper headlamp beams.

(d) When more than one reflector is required, at least one shall be mounted at the left side and one at the right side, respectively, at the same level. Required reflectors shall be mounted not lower than 15 inches nor higher than 60 inches, except that a tow truck, in addition to being equipped with the required reflectors, may also be equipped with two reflectors which may be mounted not lower than 15 inches nor higher than the maximum allowable vehicle height and as far forward as the rearmost portion of the driver's seat in the rearmost position. Additional reflectors of a type meeting requirements established by the department may be mounted at any height.

(e) Reflectors on truck tractors may be mounted on the rear of the cab. Any reflector installed on a vehicle as part of its original equipment prior to January 1, 1941, need not meet the requirements of the department provided it meets the visibility requirements of subdivision (a).

(f) Area reflectorizing material may be used in lieu of the reflectors required or permitted in subdivisions (a), (b), (c), (d), and (e), provided each installation is of sufficient size to meet the photometric requirement for those reflectors.

Added Stats 1968 ch 980 § 10. Amended Stats 1971 ch 1536 § 4; Stats 1974 ch 635 § 4; Stats 1975 ch 854 § 1; Stats 1976 ch 154 § 4; Stats 1979 ch 723 § 14; Stats 1990 ch 216 § 120 (SB 2510); Stats 1995 ch 766 § 36 (SB 726); Stats 1999 ch 140 § 7 (SB 186).

**§ 24608. Reflector requirements for buses, trailers, housecars, and motortrucks**

(a) Motortrucks, trailers, semitrailers, and buses 80 or more inches in width manufactured on or after January 1, 1968, shall be equipped with an amber reflector on

each side at the front and a red reflector on each side at the rear. Any vehicle may be so equipped.

(b) Motortrucks, trailers, semitrailers, housecars, and buses 80 or more inches in width and 30 or more feet in length manufactured on or after January 1, 1968, shall be equipped with an amber reflector mounted on each side at the approximate midpoint of the vehicle. Any such vehicle manufactured prior to January 1, 1968, may be so equipped.

(c) Required reflectors on the sides of vehicles shall be mounted not lower than 15 inches nor higher than 60 inches. Additional reflectors of a type meeting requirements established by the department may be mounted at any height.

(d) Reflectors required or permitted in subdivisions (a) and (b) shall be so maintained as to be plainly visible at night from all distances within 600 feet to 100 feet from the vehicle when directly in front of lawful upper headlamp beams.

(e) Area reflectorizing material may be used in lieu of the reflectors required or permitted in subdivisions (a) and (b), provided each installation is of sufficient size to meet the photometric requirement for such reflectors.

Added Stats 1968 ch 980 § 12. Amended Stats 1970 ch 422 § 2; Stats 1975 ch 854 § 2; Stats 1979 ch 723 § 15.

#### § 24609. Reflectors on front of vehicle

(a) A vehicle may be equipped with white or amber reflectors that are mounted on the front of the vehicle at a height of 15 inches or more, but not more than 60 inches from the ground.

(b) A schoolbus may be equipped with a set of two devices, with each device in the set consisting of an amber reflector integrated into the lens of an amber light that is otherwise permitted under this code, if the set is mounted with one device on the left side and one on the right side of the vehicle, and with each device at the same level.

Added Stats 1969 ch 341 § 4. Amended Stats 2003 ch 594 § 44 (SB 315).

#### § 24610. Multiple-unit truck reflectors

A reflector placed on vehicles under Section 24609 which is of the button or other multiple-unit type shall contain not less than seven units with a total of not less than three square inches of reflecting surface. The red reflectors required may be separate units or a part of the red taillamps, but in either event the reflector and taillamps shall comply with all of the requirements of Sections 24600, 24602, and 24609, and any reflector constituting an integral part of a taillamp shall comply with all photometric requirements applicable to a separate reflector.

Enacted Stats 1959 ch 3. Amended Stats 1959 ch 1996 § 32; Stats 1965 ch 1313 § 8.

#### § 24611. Exemption from reflector requirements for certain trailers

Trailers that are equipped with red and white reflective sheeting or reflectors on both the sides and rear and displayed in accordance with federal Motor Vehicle Safety Standard regulations (49 C.F.R. 571.108) for trailers with a width of 80 inches or more and having a gross vehicle weight rating of over 10,000 pounds need

not be equipped with the reflectors required by Section 24607 or 24608.

Added Stats 1995 ch 766 § 37 (SB 726).

#### § 24615. Slow moving vehicle emblem

It is unlawful to operate upon a public highway any vehicle or combination of vehicles, which is designed to be and is operated at a speed of 25 miles per hour or less, unless the rearmost vehicle displays a "slow-moving vehicle emblem," except upon vehicles used by a utility, whether publicly or privately owned, for the construction, maintenance, or repair of its own facilities or upon vehicles used by highway authorities or bridge or highway districts in highway maintenance, inspection, survey, or construction work, while such vehicle is engaged in work at the jobsite upon a highway. Any other vehicle or combination of vehicles, when operated at a speed of 25 miles per hour or less, may display such emblem. The emblem shall be mounted on the rear of the vehicle, base down, and at a height of not less than three nor more than five feet from ground to base. Such emblem shall consist of a truncated equilateral triangle having a minimum height of 14 inches with a red reflective border not less than 1¼ inches in width and a fluorescent orange center.

This emblem shall not be displayed except as permitted or required by this section.

Added Stats 1969 ch 949 § 1. Amended Stats 1971 ch 287 § 1.

#### § 24616. Equipping vehicle with rear-facing auxiliary lamps

(a) A motor vehicle may be equipped with one or two rear-facing auxiliary lamps. For the purposes of this section, a rear-facing auxiliary lamp is a lamp that is mounted on the vehicle facing rearward. That lamp shall meet the photometric and performance requirements of the Society of Automotive Engineers Standard J1424 for cargo lamps.

(b) A rear-facing auxiliary lamp may project only a white light, with the main cone of light projecting both rearward and downward. The main cone of light shall illuminate the road surface or ground immediately rearward of a line parallel to the rear of the vehicle for a distance not greater than 50 feet. The main cone of light may not project to the front or sides of the vehicle.

(c) A rear-facing auxiliary lamp may be activated only when the vehicle is stopped. A vehicle equipped with a rear-facing auxiliary lamp shall also be equipped with a system that allows activation of the lamp only when the vehicle is in the "park" setting, if the vehicle is equipped with an automatic transmission, or in the "neutral" setting with the parking brake engaged, if the vehicle is equipped with a manual transmission.

(d) A vehicle equipped with a rear-facing auxiliary lamp may have an activation switch accessible to the operator from the rear of the vehicle.

Added Stats 2001 ch 739 § 20 (AB 1707).

## ARTICLE 4 Parking Lamps

Section  
24800. Use of parking lamps

Section

24801. When lights need not be displayed  
24802. Use of parking lamps

**§ 24800. Use of parking lamps**

No vehicle shall be driven at any time with the parking lamps lighted except when the lamps are being used as turn signal lamps or when the headlamps are also lighted.

Enacted Stats 1959 ch 3. Amended Stats 1961 ch 58 § 45, effective March 31, 1961.

**§ 24801. When lights need not be displayed**

Parking lamps are those lamps permitted by Section 25106, or any lamps mounted on the front of a vehicle, designed to be displayed primarily when the vehicle is parked.

Enacted Stats 1959 ch 3.

**§ 24802. Use of parking lamps**

No lights need be displayed upon a vehicle which is:

- (a) Parked off the roadway and not in a hazardous position on the highway; or
- (b) Parked with a wheel within 18 inches of a curb; or
- (c) Parked within a business or residence district with a wheel within 18 inches of a curb or edge of the roadway.

Enacted Stats 1959 ch 3. Amended Stats 1961 ch 639 § 1; Stats 1977 ch 620 § 2.

**ARTICLE 5**

**Signal Lamps and Devices**

Section

24950. Turn signal system on vehicle towing trailer  
24951. Lamp-type turn signal system; Requirements  
24952. Turn signal visibility requirements  
24953. Turn signal lamps

**§ 24950. Turn signal system on vehicle towing trailer**

Whenever any motor vehicle is towing a trailer coach or a camp trailer the combination of vehicles shall be equipped with a lamp-type turn signal system.

Enacted Stats 1959 ch 3. Amended Stats 1965 ch 1012 § 2; Stats 1971 ch 1536 § 5.

**§ 24951. Lamp-type turn signal system; Requirements**

(a) Any vehicle may be equipped with a lamp-type turn signal system capable of clearly indicating any intention to turn either to the right or to the left.

(b) The following vehicles shall be equipped with a lamp-type turn signal system meeting the requirements of this chapter.

(1) Motortrucks, truck tractors, buses and passenger vehicles, other than motorcycles, manufactured and first registered on or after January 1, 1958.

(2) Trailers and semitrailers manufactured and first registered between December 31, 1957, and January 1, 1969, having a gross weight of 6,000 pounds or more.

(3) Trailers and semitrailers 80 or more inches in width manufactured on or after January 1, 1969.

(4) Motorcycles manufactured and first registered on or after January 1, 1973, except motor-driven cycles

whose speed attainable in one mile is 30 miles per hour or less.

The requirements of this subdivision shall not apply to special mobile equipment, or auxiliary dollies.

(c) Turn signal lamps on vehicles manufactured on or after January 1, 1969, shall be mounted not lower than 15 inches.

Enacted Stats 1959 ch 3. Amended Stats 1959 ch 1996 § 32.5; Stats 1961 ch 118 § 2; Stats 1963 ch 292 § 4; Stats 1965 ch 1012 § 3; Stats 1967 ch 859 § 2; Stats 1968 ch 980 § 14; Stats 1973 ch 135 § 1; Stats 1975 ch 475 § 1.

**§ 24952. Turn signal visibility requirements**

A lamp-type turn signal shall be plainly visible and understandable in normal sunlight and at nighttime from a distance of at least 300 feet to the front and rear of the vehicle, except that turn signal lamps on vehicles of a size required to be equipped with clearance lamps shall be visible from a distance of 500 feet during such times.

Enacted Stats 1959 ch 3. Amended Stats 1965 ch 1012 § 4.

**§ 24953. Turn signal lamps**

(a) Any turn signal system used to give a signal of intention to turn right or left shall project a flashing white or amber light visible to the front and a flashing red or amber light visible to the rear.

(b) Side-mounted turn signal lamps projecting a flashing amber light to either side may be used to supplement the front and rear turn signals. Side-mounted turn signal lamps mounted to the rear of the center of the vehicle may project a flashing red light no part of which shall be visible from the front.

(c) In addition to any required turn signal lamps, any vehicle may be equipped with supplemental rear turn signal lamps mounted to the rear of the rearmost portion of the driver's seat in its rearmost position.

(d) In addition to any required or authorized turn signal lamps, any vehicle may be equipped with supplemental rear turn signal lamps that are mounted on, or are an integral portion of, the outside rearview mirrors, so long as the lamps flash simultaneously with the rear turn signal lamps, the light emitted from the lamps is projected only to the rear of the vehicle and is not visible to the driver under normal operating conditions, except for a visual indicator designed to allow monitoring of lamp operation, and the lamps do not project a glaring light.

Enacted Stats 1959 ch 3. Amended Stats 1963 ch 223 § 2; Stats 1972 ch 203 § 1; Stats 1979 ch 723 § 16; Stats 1994 ch 207 § 2 (AB 2827), effective July 15, 1994; Stats 1997 ch 945 § 22 (AB 1561).

**ARTICLE 6**

**Side and Fender Lighting Equipment**

Section

25100. Clearance and side-marker lamps  
25100.1. Clearance and side-marker lamps; Ambulances  
25102. Lamps on sides of vehicles  
25102.5. Use of lamps on side of schoolbus when visibility reduced  
25103. Projecting loads  
25104. Wide vehicles  
25105. Courtesy lamps; Door-mounted lamps or reflectors; Exterior lamps



## Section

25106. Fender lamps; Side lamps  
 25107. Cornering lamps on fenders  
 25108. Turn signal pilot indicators  
 25109. Running lamps  
 25110. Utility flood or loading lamps

**§ 25100. Clearance and side-marker lamps**

(a) Except as provided in subdivisions (b) and (d), every vehicle 80 inches or more in overall width shall be equipped during darkness as follows:

(1) At least one amber clearance lamp on each side mounted on a forward-facing portion of the vehicle and visible from the front and at least one red clearance lamp on each side mounted on a rearward-facing portion of the vehicle and visible from the rear.

(2) At least one amber side-marker lamp on each side near the front and at least one red side-marker lamp on each side near the rear.

(3) At least one amber side-marker lamp on each side at or near the center on trailers and semitrailers 30 feet or more in length and which are manufactured and first registered after January 1, 1962. Any such vehicle manufactured and first registered prior to January 1, 1962, may be so equipped.

(4) At least one amber side-marker lamp mounted at approximate midpoint of housecars, motortrucks, and buses 30 or more feet in length and manufactured on or after January 1, 1969. Any such vehicle manufactured prior to January 1, 1969, may be so equipped.

(5) Combination clearance and side-marker lamps mounted as side-marker lamps and meeting the visibility requirements for both types of lamps may be used in lieu of required individual clearance or side-marker lamps.

(b) The following vehicles when 80 inches or more in overall width and not equipped as provided in subdivision (a) shall be equipped during darkness as follows:

(1) Truck tractors shall be equipped with at least one amber clearance lamp on each side on the front of the cab or sleeper and may be equipped with amber side-marker lamps on each side.

(2) Truck tractors manufactured on or after January 1, 1969, shall be equipped with one amber side-marker lamp on each side near the front.

(3) Pole or pipe dollies, or logging dollies, shall be equipped with at least one combination clearance and side-marker lamp on each side showing red to the front, side, and rear.

(4) Vehicles, except truck tractors, which are 80 inches or more in width over a distance not exceeding three feet from front to rear shall be equipped with at least one amber combination clearance lamp and side-marker lamp on each side visible from the front, side, and rear if the projection is near the front of the vehicle and at least one red lamp if the projection is near the rear of the vehicle.

(5) Towing motor vehicles engaged in driveaway-tow-away operations shall be equipped with at least one amber clearance lamp at each side on the front and at least one amber side-marker lamp on each side near the front.

(6) Towed motor vehicles engaged in driveaway-tow-away operations shall be equipped with at least one amber side-marker lamp on each side of intermediate

vehicles, and the rearmost vehicle shall be equipped with at least one red side-marker lamp on each side and at least one red clearance lamp on each side on the rear.

(7) Trailers and semitrailers designed for transporting single boats in a cradle-type mounting and for launching the boat from the rear of the trailer need not be equipped with front and rear clearance lamps provided amber clearance lamps showing to the front and red clearance lamps showing to the rear are located on each side at or near the midpoint between the front and rear of the trailer to indicate the extreme width of the trailer.

(c) Loads extending beyond the side of a vehicle where the overall width of the vehicle and load is 80 inches or more shall be equipped with an amber combination clearance and side-marker lamp on the side at the front and a red combination clearance and side-marker lamp on the side at the rear. In lieu of the foregoing requirement, projecting loads not exceeding three feet from front to rear at the extreme width shall be equipped with at least one amber combination clearance and side-marker lamp on the side visible from the front, side, and rear if the projection is near the front of the vehicle and at least one red lamp if the projection is near the rear of the vehicle.

(d) Clearance and side-marker lamps are not required on auxiliary dollies or on passenger vehicles other than a housecar.

(e) Clearance lamps shall be visible from all distances between 500 feet and 50 feet to the front or rear of the vehicle, and side-marker lamps shall be visible from all distances between 500 feet and 50 feet to the side of the vehicle.

(f) Clearance lamps shall, so far as is practicable, be mounted to indicate the extreme width of the vehicle. Side-marker lamps shall be mounted not lower than 15 inches on vehicles manufactured on and after January 1, 1968. Combination clearance and side-marker lamps required on loads shall be mounted so the lenses project to the outer extremity of the vehicle or load.

Added Stats 1961 ch 1989 § 4. Amended Stats 1963 ch 78 § 1, ch 292 § 5; Stats 1965 ch 1313 § 9; Stats 1968 ch 980 § 15; Stats 1970 ch 422 § 3; Stats 1975 ch 854 § 3; Stats 1976 ch 900 § 1; Stats 1981 ch 714 § 446.

**§ 25100.1. Clearance and side-marker lamps; Ambulances**

Notwithstanding any other provisions of this code, an ambulance may be equipped with clearance and side-marker lamps.

Added Stats 1975 ch 616 § 1.

**§ 25102. Lamps on sides of vehicles**

In addition to the lamps otherwise permitted by this chapter, any motor vehicle may be equipped with lamps on the sides thereof, visible from the side of the vehicle but not from the front or rear thereof, which lamps together with mountings or receptacles, shall be set into depressions or recesses in the body of the vehicle and shall not protrude beyond or outside the body of the vehicle. The light source in each of the lamps shall not exceed two candlepower and shall emit diffused light of any color, except that the color red is permitted only on authorized emergency vehicles.

Enacted Stats 1959 ch 3.

**§ 25102.5. Use of lamps on side of schoolbus when visibility reduced**

(a) A schoolbus may be equipped with lamps mounted so as to be visible from the sides of the bus which may be lighted, in addition to other required lights, when, and only when, atmospheric conditions such as fog, rain, snow, smoke, or dust, reduce the visibility of other vehicles to less than 500 feet.

(b) The type and mounting requirements of such lamps shall be established by regulations adopted by the department. The regulations shall be adopted by January 1, 1980.

Added Stats 1978 ch 543 § 1. Amended Stats 1979 ch 723 § 17.

**§ 25103. Projecting loads**

Whenever the load upon any vehicle extends from the left side of the vehicle one foot or more, there shall be displayed at the extreme left side of the load during darkness:

(a) An amber lamp plainly visible for 300 feet to the front and rear of the vehicle.

(b) An amber lamp at the front visible for 300 feet to the front and a red lamp at the rear plainly visible for 300 feet to the rear of the vehicle if the projecting load exceeds 120 inches in length.

The lamp shall not contain a bulb rated in excess of six candlepower.

Enacted Stats 1959 ch 3. Amended Stats 1981 ch 774 § 1.

**§ 25104. Wide vehicles**

Any vehicle or equipment that requires a permit issued pursuant to Article 6 (commencing with Section 35780) of Chapter 5 of Division 15 because it is wider than permitted under Chapter 2 (commencing with Section 35100) of Division 15 shall display a solid red or fluorescent orange flag or cloth not less than 12 inches square at the extreme left front and left rear of the vehicle or equipment, if the vehicle or equipment is being operated other than during darkness.

Enacted Stats 1959 ch 3. Amended Stats 1994 ch 675 § 8 (SB 1741); Stats 1998 ch 828 § 19 (SB 1637).

**§ 25105. Courtesy lamps; Door-mounted lamps or reflectors; Exterior lamps**

(a) Any motor vehicle may be equipped with running board or door-mounted courtesy lamps. The bulbs in the lamps shall not exceed six standard candlepower and shall emit either a green or white light without glare. The beams of the lamps shall not be visible to the front or rear of the vehicle.

(b) Any motor vehicle may be equipped with inside door-mounted red lamps or red reflectorizing devices or material visible to the rear of the vehicle when the doors are open. The bulbs in the lamps shall not exceed six standard candlepower.

(c) Any motor vehicle may be equipped with exterior lamps for the purpose of lighting the entrances and exits of the vehicles, which lamps may be lighted only when the vehicles are not in motion. The lamp source of the exterior lamps shall not exceed 32 standard candlepower, or 30 watts, nor project any glaring light into the eyes of an approaching driver.

Enacted Stats 1959 ch 3. Amended Stats 1965 ch 314 § 1; Stats 1967 ch 443 § 1; Stats 1977 ch 287 § 4; Stats 1995 ch 348 § 1 (AB 1597).

**§ 25106. Fender lamps; Side lamps**

(a) Any motor vehicle may be equipped with lighted white or amber cowl or fender lamps on the front. Any vehicle may be equipped with not more than one amber side lamp on each side near the front, nor more than one red side lamp on each side near the rear. The light source of each such lamp shall not exceed four standard candlepower.

(b) Lamps meeting requirements established by the department for side-marker or combination clearance and side-marker lamps may be installed on the sides of vehicles at any location, but any lamp installed within 24 inches of the rear of the vehicle shall be red, and any lamp installed at any other location shall be amber.

Added Stats 1967 ch 728 § 2. Amended Stats 1970 ch 422 § 3.5; Stats 1975 ch 854 § 4; Stats 1978 ch 252 § 4, effective June 16, 1978; Stats 1979 ch 723 § 18.

**§ 25107. Cornering lamps on fenders**

Any motor vehicle may be equipped with not more than two cornering lamps designed and of sufficient intensity for the purpose of revealing objects only in the direction of turn while the vehicle is turning or while the turn signal lamps are operating to signal an intention to turn. The lamps shall be designed so that no glaring light is projected into the eyes of an approaching driver.

Enacted Stats 1959 ch 3. Amended Stats 1961 ch 159 § 3; Stats 1965 ch 1313 § 10.

**§ 25108. Turn signal pilot indicators**

(a) Any motor vehicle may be equipped with not more than two amber turn-signal pilot indicators mounted on the exterior. The light output from any indicator shall not exceed five candlepower unless a provision is made for operating the indicator at reduced intensity during darkness in which event the light output shall not exceed five candlepower during darkness or 15 candlepower at any other time. The center of the beam shall be projected toward the driver.

(b) Any vehicle may be equipped with pilot indicators visible from the front to monitor the functioning or condition of parts essential to the operation of the vehicle or of equipment attached to the vehicle that is necessary for protection of the cargo or load. The pilot indicators shall be steady-burning, having a projected lighted lens area of not more than three-quarters of a square inch and have a light output of not more than five candlepower. The pilot indicator may be of any color except red.

(c) Other exterior pilot indicators of any color may be used for monitoring exterior lighting devices, provided that the area of each indicator is less than 0.20 square inches, the intensity of each indicator does not exceed 0.10 candlepower, and the color red is not visible to the front.

(d) Any towed vehicle may be equipped with an exterior-mounted indicator lamp used only to indicate the functional status of an antilock braking system providing that either of the following conditions are met:

(1) The indicator lamp complies with the applicable requirements of the federal motor vehicle safety standards.

(2) The indicator lamp is designed and located so that it will be readily visible, with the assistance of a rear-view mirror if necessary, to the driver of the towing

motor vehicle and the indicator lamp has a light source not exceeding five candlepower. The light shall not show to the sides or rear of the vehicle and the indicator lamp may emit any color except red.

(e)(1) Notwithstanding any other provision of law, any motor vehicle may be equipped with not more than two exterior-lighted data monitors that transmit information to the driver of the vehicle regarding the efficient or safe operation, or both the efficient and safe operation, of the vehicle.

(2) Data monitors shall comply with all of the following conditions:

(A) Be mounted to the vehicle in a manner so that they are readily visible to the driver of the vehicle when the driver is seated in the normal driving position. Data monitors shall not be designed to convey information to any person other than the driver of the vehicle.

(B) Be limited in size to not more than two square inches of lighted area each.

(C) Not emit a light brighter than reasonably necessary to convey the intended information.

(D) Not project a glaring light to the driver or, to other motorists, or to any other person.

(3) Data monitors may incorporate flashing or changing elements only as necessary to convey the intended information. Data monitors shall not resemble any official traffic-control device or required lighting device or be combined with any required lighting device.

(4) Data monitors may display any color, except that the color red shall not be visible to the front of the vehicle.

Added Stats 1961 ch 159 § 4. Amended Stats 1963 ch 223 § 3; Stats 1967 ch 440 § 2, effective June 30, 1967; Stats 1980 ch 349 § 1; Stats 1983 ch 142 § 170; Stats 1994 ch 675 § 9 (SB 1741); Stats 1998 ch 938 § 3 (SB 1754). Amended Stats 2001 ch 739 § 21 (AB 1707).

### § 25109. Running lamps

Any motor vehicle may be equipped with two white or amber running lamps mounted on the front, one at each side, which shall not be lighted during darkness except while the motor vehicle is parked.

Added Stats 1965 ch 858 § 2.

### § 25110. Utility flood or loading lamps

(a) The following vehicles may be equipped with utility flood or loading lamps mounted on the rear, and sides, that project a white light illuminating an area to the side or rear of the vehicle for a distance not to exceed 75 feet at the level of the roadway:

(1) Tow trucks that are used to tow disabled vehicles may display utility floodlights, but only during the period of preparation for towing at the location from which a disabled vehicle is to be towed.

(2) Ambulances used to respond to emergency calls may display utility flood and loading lights, but only at the scene of an emergency or while loading or unloading patients.

(3) Firefighting equipment designed and operated exclusively as such may display utility floodlamps only at the scene of an emergency.

(4) Vehicles used by law enforcement agencies or organizations engaged in the detoxification of alcoholics may display utility flood or loading lights when loading or unloading persons under the influence of intoxicants

for transportation to detoxification centers or places of incarceration.

(5) Vehicles used by law enforcement agencies for mobile blood alcohol testing, drug evaluation, or field sobriety testing.

(6) Vehicles used by publicly or privately owned public utilities may display utility flood or loading lights when engaged in emergency roadside repair of electric, gas, telephone, telegraph, water, or sewer facilities.

(b) Lamps permitted under subdivision (a) shall not be lighted during darkness, except while the vehicle is parked, nor project any glaring light into the eyes of an approaching driver.

Added Stats 1975 ch 551 § 1. Amended Stats 1981 ch 518 § 1; Stats 1988 ch 924 § 14; Stats 1996 ch 124 § 132 (AB 3470).

## ARTICLE 7

### Flashing and Colored Lights

#### Section

25250. General rule on use of flashing lights

25251. When flashing lights permitted

25251.1. Implements of husbandry; Use of turn signals as warning lights

25251.2. Flashing lights on motorcycles

25251.3. Civil liability based on use or nonuse of turn signals

25251.4. Theft alarm systems

25251.5. Deceleration warning lights

25252. Warning lights on authorized emergency vehicles

25252.5. Flashing headlamps on authorized emergency vehicles

25253. Warning lights on tow trucks; Exception on freeway

25254. Warning lights on vehicles operated by personnel of marshal's department

25256. Warning lights on highway maintenance vehicles

25257. School bus signal lights; "Stop signal arm"

25257.2. Warning lights on school buses used to transport developmentally disabled persons

25257.5. Backup warning by school buses

25258. Flashing signal controlling or blue lights for use on authorized emergency vehicles only

25259. Additional warning lights on authorized emergency vehicles

25259.5. Warning lights on Red Cross emergency or disaster service vehicles

25260. Warning lights on public utility vehicles

25260.1. Warning lights on vehicles engaged in construction, removal, or inspection of oil or gas pipeline

25260.3. Warning lights on vehicle with personnel aerial lift

25260.4. Warning lights on hazardous substance spill response vehicles

25261. Warning lights on county vehicles engaged in weed control or pest detection

25262. Red lights on armored cars

25263. Warning lights on house towing trucks

25264. Warning lights on coroner vehicles

25265. Warning lights on sanitation district repair vehicles

25266. Warning lights on vehicles engaged in aqueduct, levee, or stream measurement work

25267. Warning lights on pest abatement vehicles

25268. Improper use of flashing amber warning light

25269. Improper use of red warning light

25270. Warning lights on pilot cars and related vehicles

25270.5. Warning lights on vehicles herding livestock

25271. Warning lights on pet ambulances

25271.5. Warning lights on vehicles used for enforcing animal control laws

25272. Warning lights on rural mail vehicles

25273. Warning lights on school district vehicles

25274. Warning lights on cable television vehicle

25275. Warning lamp on trucks with long loads

25275.5. Buses; Crime alarm lights

25276. Warning lights on vehicles transporting persons with intellectual or physical disabilities

25277. Warning lights on vehicles enforcing parking laws

25278. Warning lights on vehicle owned or operated by land surveyor or civil engineer

Section

- 25279. Warning lights on private security vehicles
- 25280. Warning lights on garbage collection vehicles
- 25281. Display of flashing amber warning lights by privately owned or operated water tender vehicle
- 25282. Amber warning lights

**§ 25250. General rule on use of flashing lights**

Flashing lights are prohibited on vehicles except as otherwise permitted.

Enacted Stats 1959 ch 3. Amended Stats 1963 ch 223 § 4.

**§ 25251. When flashing lights permitted**

(a) Flashing lights are permitted on vehicles as follows:

(1) To indicate an intention to turn or move to the right or left upon a roadway, turn signal lamps and turn signal exterior pilot indicator lamps and side lamps permitted under Section 25106 may be flashed on the side of a vehicle toward which the turn or movement is to be made.

(2) When disabled or parked off the roadway but within 10 feet of the roadway, or when approaching, stopped at, or departing from, a railroad grade crossing, turn signal lamps may be flashed as warning lights if the front turn signal lamps at each side are being flashed simultaneously and the rear turn signal lamps at each side are being flashed simultaneously.

(3) To warn other motorists of accidents or hazards on a roadway, turn signal lamps may be flashed as warning lights while the vehicle is approaching, overtaking, or passing the accident or hazard on the roadway if the front turn signal lamps at each side are being flashed simultaneously and the rear turn signal lamps at each side are being flashed simultaneously.

(4) For use on authorized emergency vehicles.

(5) To warn other motorists of a funeral procession, turn signal lamps may be flashed as warning lights on all vehicles actually engaged in a funeral procession, if the front turn signal lamps at each side are being flashed simultaneously and the rear turn signal lamps at each side are being flashed simultaneously.

(b) Turn signal lamps shall be flashed as warning lights whenever a vehicle is disabled upon the roadway and the vehicle is equipped with a device to automatically activate the front turn signal lamps at each side to flash simultaneously and the rear turn signal lamps at each side to flash simultaneously, if the device and the turn signal lamps were not rendered inoperative by the event which caused the vehicle to be disabled.

(c) Side lamps permitted under Section 25106 and used in conjunction with turn signal lamps may be flashed with the turn signal lamps as part of the warning light system, as provided in paragraphs (2) and (3) of subdivision (a).

(d) Required or permitted lamps on a trailer or semitrailer may flash when the trailer or semitrailer has broken away from the towing vehicle and the connection between the vehicles is broken.

(e) Hazard warning lights, as permitted by paragraphs (2) and (3) of subdivision (a) may be flashed in a repeating series of short and long flashes when the driver is in need of help.

Enacted Stats 1959 ch 3. Amended Stats 1959 ch 1996 § 33; Stats 1961 ch 58 § 46, effective March 31, 1961, ch 159 § 5, ch 653 § 29, operative

January 1, 1962; Stats 1963 ch 223 § 5; Stats 1965 ch 1125 § 1; Stats 1970 ch 422 § 4; Stats 1972 ch 203 § 2; Stats 1977 ch 445 § 1; Stats 1981 ch 774 § 2; Stats 1983 ch 410 § 1; Stats 1984 ch 121 § 1; Stats 1986 ch 256 § 2; Stats 1997 ch 945 § 23 (AB 1561).

**§ 25251.1. Implements of husbandry; Use of turn signals as warning lights**

Any implement of husbandry displaying a slow moving vehicle emblem, as defined in Section 24615, and being operated at a speed of 25 miles per hour or less, may be equipped with double-faced amber turn signals which may be flashed simultaneously as warning lights.

Added Stats 1978 ch 252 § 5, effective June 16, 1978.

**§ 25251.2. Flashing lights on motorcycles**

Any motorcycle may be equipped with a means of modulating the upper beam of the headlamp between a high and a lower brightness at a rate of 200 to 280 flashes per minute. Such headlamps shall not be so modulated during darkness.

Added Stats 1980 ch 35 § 1, effective March 7, 1980.

**§ 25251.3. Civil liability based on use or nonuse of turn signals**

No civil liability shall attach to any person for the use or nonuse of turn signal lamps in the manner permitted by paragraph (3) or (5) of subdivision (a) of Section 25251, except for such civil liability as would attach for the use or nonuse of any other device required by this article or Article 8 (commencing with Section 25300).

Added Stats 1977 ch 445 § 3. Amended Stats 1983 ch 410 § 2.

**§ 25251.4. Theft alarm systems**

Any motor vehicle may also be equipped with a theft alarm system which flashes any of the lights required or permitted on the motor vehicle and which operates as specified in Article 13 (commencing with Section 28085) of Chapter 5 of this division.

Added Stats 1977 ch 993 § 1.

**§ 25251.5. Deceleration warning lights**

(a) Any motor vehicle may also be equipped with a system in which an amber light is center mounted on the rear of a vehicle to communicate a component of deceleration of the vehicle, and which light pulses in a controlled fashion at a rate which varies exponentially with a component of deceleration.

(b) Any motor vehicle may be equipped with two amber lamps on the rear of the vehicle which operate simultaneously with not more than four flashes within four seconds after the accelerator pedal is in the deceleration position and which are not lighted at any other time. The lamps shall be mounted at the same height, with one lamp located on each side of the vertical centerline of the vehicle, not higher than the bottom of the rear window, or if the vehicle has no rear window, not higher than 60 inches. The light output from each of the lamps shall not exceed 200 candlepower at any angle horizontal or above. The amber lamps may be used either separately or in combination with another lamp.

(c) Any stoplamp or supplemental stoplamp required or permitted by Section 24603 may be equipped so as to

flash not more than four times within the first four seconds after actuation by application of the brakes.

Added Stats 1972 ch 740 § 1, as Veh C § 25251.1. Amended Stats 1974 ch 574 § 1. Renumbered by Stats 1977 ch 445 § 2. Amended Stats 1982 ch 261 § 1; Stats 1983 ch 410 § 3.

#### § 25252. Warning lights on authorized emergency vehicles

Every authorized emergency vehicle shall be equipped with at least one steady burning red warning lamp visible from at least 1,000 feet to the front of the vehicle to be used as provided in this code.

In addition, authorized emergency vehicles may display revolving, flashing, or steady red warning lights to the front, sides or rear of the vehicles.

Enacted Stats 1959 ch 3. Amended Stats 1961 ch 653 § 30, operative January 1, 1961; Stats 1974 ch 635 § 6.

#### § 25252.5. Flashing headlamps on authorized emergency vehicles

(a) Every authorized emergency vehicle may be equipped with a system which flashes the upper-beam headlamps of the vehicle with the flashes occurring alternately from the front headlamp on one side of the vehicle to the front headlamp on the other side of the vehicle. The flashing of the headlamps shall consist only of upper-beam flashing, and not the flashing of any other light beam.

(b) "Upper-beam headlamp," as used in this section, means a headlamp or that part of a headlamp which projects a distribution of light, or composite beam, so aimed and of such intensity as to reveal persons and vehicles at a distance of at least 350 feet ahead for all conditions of loading.

(c) The system provided for in subdivision (a) shall only be used when an authorized emergency vehicle is being operated pursuant to Section 21055.

Added Stats 1970 ch 681 § 1. Amended Stats 1972 ch 203 § 3; Stats 1979 ch 723 § 19; Stats 1983 ch 1017 § 4.

#### § 25253. Warning lights on tow trucks; Exception on freeway

(a) Tow trucks used to tow disabled vehicles shall be equipped with flashing amber warning lamps. This subdivision does not apply to a tractor-trailer combination.

(b) Tow trucks may display flashing amber warning lamps while providing service to a disabled vehicle. A flashing amber warning lamp upon a tow truck may be displayed to the rear when the tow truck is towing a vehicle and moving at a speed slower than the normal flow of traffic.

(c) A tow truck shall not display flashing amber warning lamps on a freeway except when an unusual traffic hazard or extreme hazard exists.

Enacted Stats 1959 ch 3. Amended Stats 1961 ch 653 § 31, operative January 1, 1962; Stats 1980 ch 399 § 4, effective July 11, 1980; Stats 1981 ch 774 § 3; Stats 1988 ch 924 § 15; Stats 1995 ch 404 § 9 (SB 240); Stats 2006 ch 375 § 3 (SB 1610), effective January 1, 2007, repealed January 1, 2010; Stats 2009 ch 33 §§ 2, 3 (SB 159), effective January 1, 2010.

#### § 25254. Warning lights on vehicles operated by personnel of marshal's department

In any county with a population of 250,000 or more persons, publicly owned vehicles operated by peace offi-

cer personnel of a marshal's department, when actually being used in the enforcement of the orders of any court, including, but not limited to, the transportation of prisoners, may display flashing amber warning lights to the rear when such vehicles are necessarily parked upon a roadway and such parking constitutes a hazard to other motorists.

Added Stats 1973 ch 401 § 1. Amended Stats 1974 ch 934 § 1.

#### § 25256. Warning lights on highway maintenance vehicles

Vehicles used by highway authorities or bridge and highway districts and vehicles of duly authorized representatives thereof, used in highway maintenance, inspection, survey or construction work may display flashing amber warning lights to the front, sides or rear when such vehicles are parked or working on the highway.

Enacted Stats 1959 ch 3. Amended Stats 1961 ch 653 § 34, operative January 1, 1962; Stats 1967 ch 544 § 4.

#### § 25257. School bus signal lights; "Stop signal arm"

(a) Every schoolbus, when operated for the transportation of schoolchildren, shall be equipped with a flashing red light signal system.

(b)(1) Every schoolbus manufactured on or after September 1, 1992, shall also be equipped with a stop signal arm. Any schoolbus manufactured before September 1, 1992, may be equipped with a stop signal arm.

(2) Any schoolbus manufactured on or after July 1, 1993, shall also be equipped with an amber warning light system, in addition to the flashing red light signal system. Any schoolbus manufactured before July 1, 1993, may be equipped with an amber warning light system.

(3) On or before September 1, 1992, the department shall adopt regulations governing the specifications, installation, and use of stop signal arms, to comply with federal standards.

(4) A "stop signal arm" is a device that can be extended outward from the side of a schoolbus to provide a signal to other motorists not to pass the bus because it has stopped to load or unload passengers, that is manufactured pursuant to the specifications of Federal Motor Vehicle Safety Standard No. 131, issued on April 25, 1991.

Enacted Stats 1959 ch 3. Amended Stats 1992 ch 624 § 7 (AB 3144), effective September 11, 1992.

#### § 25257.2. Warning lights on school buses used to transport developmentally disabled persons

If a schoolbus is used for the transportation of persons of any age who are developmentally disabled, as defined by the Lanterman Developmental Disabilities Services Act (Division 4.5 (commencing with Section 4500) of the Welfare and Institutions Code), the amber light signal system, flashing red light signal system, and stop signal arm shall not be used other than as required by Sections 22112 and 22454.

Added Stats 1986 ch 678 § 2. Amended Stats 1992 ch 624 § 8 (AB 3144), effective September 11, 1992.

#### § 25257.5. Backup warning by school buses

To warn other motorists or pedestrians on a roadway during a backing maneuver, the operator of a schoolbus

may flash turn signal lamps if the front turn signal lamps at each side are flashed simultaneously and the rear signal lamps at each side are flashed simultaneously.

Added Stats 1984 ch 127 § 1.

**§ 25258. Flashing signal controlling or blue lights for use on authorized emergency vehicles only**

(a) An authorized emergency vehicle operating under the conditions specified in Section 21055 may display a flashing white light from a gaseous discharge lamp designed and used for the purpose of controlling official traffic control signals.

(b) An authorized emergency vehicle used by a peace officer, as defined in Section 830.1 of, subdivision (a), (b), (c), (d), (e), (f), (g), or (i) of Section 830.2 of, subdivision (n) of Section 830.3 of, subdivision (b) of Section 830.31 of, subdivision (a) or (b) of Section 830.32 of, Section 830.33 of, subdivision (a) of Section 830.36 of, subdivision (a) of Section 830.4 of, or Section 830.6 of, the Penal Code, in the performance of the peace officer's duties, may, in addition, display a steady or flashing blue warning light visible from the front, sides, or rear of the vehicle.

(c) Except as provided in subdivision (a), a vehicle shall not be equipped with a device that emits any illumination or radiation that is designed or used for the purpose of controlling official traffic control signals.

Enacted Stats 1959 ch 3. Amended Stats 1967 ch 1037 § 1; Stats 1974 ch 255 § 1; Stats 1979 ch 723 § 20; Stats 1981 ch 1112 § 2; Stats 1982 ch 954 § 2; Stats 1987 ch 429 § 2; Stats 1989 ch 245 § 1, ch 1165 § 48; Stats 1990 ch 82 § 18 (SB 655), effective May 2, 1990, ch 1695 § 13 (SB 2140); Stats 1991 ch 13 § 54 (AB 37), effective February 13, 1991; Stats 1996 ch 1154 § 74 (AB 3020), effective September 30, 1996; Stats 1997 ch 945 § 24 (AB 1561); Stats 1998 ch 828 § 20 (SB 1637). Amended Stats 2004 ch 198 § 3 (SB 1236); Stats 2010 ch 618 § 295 (AB 2791), effective January 1, 2011.

**§ 25259. Additional warning lights on authorized emergency vehicles**

(a) Any authorized emergency vehicle may display flashing amber warning lights to the front, sides, or rear.

(b) A vehicle operated by a police or traffic officer while in the actual performance of his or her duties may display steady burning or flashing white lights to either side mounted above the roofline of the vehicle.

(c) Any authorized emergency vehicle may display not more than two flashing white warning lights to the front mounted above the roofline of the vehicle and not more than two flashing white warning lights to the front mounted below the roofline of the vehicle. These lamps may be in addition to the flashing headlamps permitted under Section 25252.5.

Enacted Stats 1959 ch 3. Amended Stats 1959 ch 974 § 1; Stat 1961 ch 653 § 35, operative January 1, 1962; Stats 1965 ch 1357 § 1; Stats 1978 ch 252 § 6, effective June 16, 1978; Stats 1979 ch 723 § 21; Stats 1991 ch 13 § 55 (AB 37), effective February 13, 1991; Stats 1997 ch 945 § 25 (AB 1561).

**§ 25259.5. Warning lights on Red Cross emergency or disaster service vehicles**

An emergency response or disaster service vehicle owned or leased and operated by the American National Red Cross, or any chapter or branch thereof, and equipped and clearly marked as a Red Cross emergency

service or disaster service vehicle, may display flashing amber warning lights to the front, sides, or rear of the vehicle while at the scene of an emergency or disaster operation. Vehicles not used on emergency response shall not be included.

Added Stats 1986 ch 178 § 1. Amended Stats 1997 ch 144 § 2 (AB 924).

**§ 25260. Warning lights on public utility vehicles**

(a) Public utility vehicles, and vehicles of duly authorized representatives of a public utility, actually engaged in the construction, removal, maintenance, or inspection of public utility facilities, including the cutting or trimming of trees immediately adjacent thereto, may display flashing amber warning lights to the front, sides, or rear when necessarily parked on a highway or when moving at a speed slower than the normal flow of traffic.

(b) Vehicles owned by public transit operators which provide assistance to a disabled district bus may display flashing amber warning lights to the front, sides, or rear when necessarily parked on a highway.

Enacted 1959 ch 3. Amended Stats 1961 ch 653 § 36, operative January 1, 1962; Stats 1965 ch 1353 § 1; Stats 1980 ch 399 § 5, effective July 11, 1980.

**§ 25260.1. Warning lights on vehicles engaged in construction, removal, or inspection of oil or gas pipeline**

Vehicles actually engaged in the construction, removal, maintenance, or inspection of any oil or gas pipeline may display flashing amber warning lights to the front, sides, or rear when necessarily parked on a highway or when necessarily moving at a speed slower than the normal flow of traffic and only in accordance with Section 25268.

Added Stats 1978 ch 120 § 1.

**§ 25260.3. Warning lights on vehicle with personnel aerial lift**

Any vehicle having personnel aerial lift equipment, actually engaged in the construction, removal, maintenance or inspection of any building, structure, or appurtenances thereto, including the cutting or trimming of trees immediately adjacent thereto, may display flashing amber warning lights to the front, sides, or rear when necessarily parked on a highway or when moving at a speed slower than the normal flow of the traffic.

Added Stats 1976 ch 334 § 1.

**§ 25260.4. Warning lights on hazardous substance spill response vehicles**

Any hazardous substance spill response vehicle, under contract to the Department of Transportation for the cleanup of hazardous substance spills, may display flashing amber warning lights to the front, sides, or rear of the vehicle while it is engaged in the actual cleanup of the spill. The warning lights shall be removed or covered with opaque material whenever the vehicle is not actually engaged in the cleanup of a hazardous substance at the scene of the spill.

Added Stats 1984 ch 887 § 1, effective September 5, 1984.

**§ 25261. Warning lights on county vehicles engaged in weed control or pest detection**

Vehicles used by a county or county department of agriculture and vehicles of duly authorized representa-

tives thereof, actually engaged in weed control or pest detection, may display flashing amber warning lights to the front, sides, or rear when necessarily parked on a highway or when moving at a speed slower than the normal flow of traffic.

Added Stats 1969 ch 218 § 1.

**§ 25262. Red lights on armored cars**

An armored car may be equipped with red lights which may be used while resisting armed robbery. At all other times the red lights shall not be lighted. The authority to use red lights granted by this section does not constitute an armored car an authorized emergency vehicle, and all other provisions of this code applicable to drivers of vehicles apply to drivers of armored cars.

Enacted Stats 1959 ch 3. Amended Stats 1969 ch 9 § 5, effective March 6, 1969.

**§ 25263. Warning lights on house towing trucks**

Trucks actually engaged in the towing of houses or buildings upon any highway may display flashing amber warning lights to the front, sides or rear on the vehicle or load.

Enacted Stats 1959 ch 3. Amended Stats 1961 ch 653 § 38.

**§ 25264. Warning lights on coroner vehicles**

Any motor vehicle operated by a coroner, or by a deputy coroner, and which is at the scene of any violent highway death, may display flashing amber warning lights to the front or rear.

Added Stats 1961 ch 653 § 40, operative January 1, 1962.

**§ 25265. Warning lights on sanitation district repair vehicles**

Repair vehicles of sanitary districts or county sanitation districts necessarily parked other than adjacent to the curb in a highway for purposes of repairing district facilities, may display flashing amber warning lights to the front, sides or rear, but these lights shall not be lighted when the vehicle is in motion.

Added Stats 1959 ch 809 § 1. Amended Stats 1961 ch 653 § 41, operative January 1, 1962.

**§ 25266. Warning lights on vehicles engaged in aqueduct, levee, or stream measurement work**

Vehicles owned by the state and operated by officers or employees of the state who are actually engaged in aqueduct or levee construction, maintenance, patrol, or inspection, or in stream measurement work, may display flashing amber warning lights to the front, sides and rear when parked on the traveled roadway so as to partially obstruct the free flow of traffic, or when moving at a speed slower than the normal flow of traffic.

Added Stats 1959 ch 1501 § 1. Amended Stats 1961 ch 653 § 42, operative January 1, 1962; Stats 1973 ch 763 § 1.

**§ 25267. Warning lights on pest abatement vehicles**

Vehicles used by mosquito abatement districts or pest abatement districts when dispersing insecticides may display flashing amber warning lights to the front or rear while the vehicles are parked or working on the highway.

Added Stats 1961 ch 653 § 43, operative January 1, 1962.

**§ 25268. Improper use of flashing amber warning light**

No person shall display a flashing amber warning light on a vehicle as permitted by this code except when an unusual traffic hazard exists.

Added Stats 1961 ch 653 § 44, operative January 1, 1962.

**§ 25269. Improper use of red warning light**

No person shall display a flashing or steady burning red warning light on a vehicle except as permitted by Section 21055 or when an extreme hazard exists.

Added Stats 1961 ch 653 § 45, operative January 1, 1962.

**§ 25270. Warning lights on pilot cars and related vehicles**

Any pilot car required by the permit referred to in Section 35780 or 35790, or any vehicle or combination of vehicles subject to the permit if specified in the permit, shall be equipped with flashing amber warning lights to the front, sides or rear. The pilot car and any vehicles required by the permit to have flashing amber warning lights, shall display the flashing amber warning lights while actually engaged in the movement described in the permit. The warning lamps shall be removed or covered with opaque material whenever the pilot car is not escorting the movement described in the permit.

Added Stats 1961 ch 653 § 46, operative January 1, 1962. Amended Stats 1973 ch 64 § 1; Stats 1981 ch 774 § 4; Stats 1988 ch 460 § 1.

**§ 25270.5. Warning lights on vehicles herding livestock**

Any motor vehicle engaged in, or aiding in, the herding of livestock along or across a public roadway may display flashing amber warning lights to the front, sides, or rear of the vehicle while it is stopped in the roadway near the livestock or is proceeding with the livestock along the roadway.

Added Stats 1974 ch 1145 § 1. Amended Stats 1975 ch 391 § 1; Stats 1977 ch 287 § 5.

**§ 25271. Warning lights on pet ambulances**

Any publicly owned vehicle or any vehicle operated by a corporation incorporated under Part 4 (commencing with Section 10400) of Division 2 of Title 1 of the Corporations Code for the purpose of the prevention of cruelty to animals, when used for removing dead animals, injured animals, or loose livestock, may, display flashing amber warning lights to the front or rear when necessarily parked on the roadway or when moving at a speed slower than the normal flow of traffic.

Added Stats 1961 ch 653 § 47, operative January 1, 1962.

**§ 25271.5. Warning lights on vehicles used for enforcing animal control laws**

Any publicly owned vehicle used for the enforcement of animal control laws contained in a statute, local ordinance, or regulation may display flashing or revolving amber warning lights to the front, sides, or rear of the vehicle when actually engaged in the enforcement of those laws and when necessarily parked on a roadway or moving at a speed slower than the normal flow of traffic.

Added Stats 1985 ch 131 § 1.

**§ 25272. Warning lights on rural mail vehicles**

A motor vehicle used by a rural mail carrier may display flashing amber warning lights to the front and rear of the vehicle while the vehicle is necessarily stopped or stopping upon a roadway for the delivery of United States mail.

Added Stats 1961 ch 653 § 48, operative January 1, 1962.

**§ 25273. Warning lights on school district vehicles**

Any motor vehicle owned and operated by a school district with an average daily attendance in excess of 400,000 while being used to measure the distance from school to a school pupil's residence may display a flashing amber warning light to the rear of the vehicle when moving at a speed substantially slower than the normal flow of traffic.

Added Stats 1963 ch 404 § 1.

**§ 25274. Warning lights on cable television vehicle**

Any vehicle owned by a cable television company and operated by employees, or duly authorized representatives, of a cable television company, when actually engaged in the construction, removal, maintenance or inspection of cable television facilities, including but not limited to, the cutting or trimming of trees immediately adjacent thereto, may display flashing amber warning lights to the front, sides, or rear when necessarily parked on a highway or when moving at a speed slower than the normal flow of traffic.

For the purposes of this section, "cable television company" means any person engaged in the business of transmitting television programs by cable to subscribers for a fee.

Added Stats 1972 ch 406 § 1.

**§ 25275. Warning lamp on trucks with long loads**

Any truck or truck tractor which is primarily used in the transportation of loads specified in subdivision (a) of Section 35414, may be equipped with a flashing amber warning lamp. Such lamp may be displayed to the front, sides, or rear of the combination only when its length exceeds 75 feet and when an unusual traffic hazard exists.

Added Stats 1973 ch 64 § 2.

**§ 25275.5. Buses; Crime alarm lights**

Any bus operated either by a public agency or under the authority of a certificate of public convenience and necessity issued by the Public Utilities Commission may be equipped with a system of crime alarm lights. The system of crime alarm lights shall consist of the installation of additional lamp sources, not exceeding 32 standard candlepower or 30 watts, in the front and rear clearance lamps required or permitted by Section 25100. Such lamps shall be operated by a flasher unit or units that are not audible inside the bus. When actuated, both rear crime alarm lights shall flash simultaneously and both front crime alarm lights shall flash simultaneously. Crime alarm lights shall be actuated only when a crime is in progress on board the bus or has recently been committed on board the bus.

Added Stats 1975 ch 777 § 1. Amended Stats 1979 ch 723 § 22.

**§ 25276. Warning lights on vehicles transporting persons with intellectual or physical disabilities**

(a) A motor vehicle designed for carrying more than eight persons, including the driver, owned by a private, nonprofit organization that provides training or other activities for persons who have intellectual or physical disabilities, or both, and that is certified by the Department of Rehabilitation or licensed by the State Department of Developmental Services, with respect to the providing of this training or other activities, may be equipped with a flashing amber light signal system.

(b) A motor vehicle, described in subdivision (a), may, while actually engaged in the transportation of persons described in subdivision (a) to or from a training or activity center operated by the organization, display the flashing amber lights of the system when necessarily parked upon a highway and in the process of loading or unloading persons.

(c) Subdivisions (a) and (b) apply to a motor vehicle that is rented, leased, or chartered by the organization.

Added Stats 1975 ch 683 § 1. Amended Stats 2004 ch 404 § 19 (SB 1725); Stats 2012 ch 448 § 45 (AB 2370), effective January 1, 2013, ch 457 § 45 (SB 1381), effective January 1, 2013.

**§ 25277. Warning lights on vehicles enforcing parking laws**

Any vehicle used by any police department, sheriff's office, or other governmental agency for the purpose of enforcing parking laws contained in the Vehicle Code or in a local ordinance or regulation may display flashing or revolving amber warning lights to the front, sides, or rear of the vehicle when actually engaged in the enforcement of such laws and when either necessarily stopped on a street, or when moving at a speed slower than the normal flow of traffic.

Added Stats 1976 ch 234 § 2.

**§ 25278. Warning lights on vehicle owned or operated by land surveyor or civil engineer**

Any vehicle owned or operated by a land surveyor or civil engineer licensed to practice in this state may display flashing amber warning lights to the front, sides, or rear, if the vehicle is engaged in any phase of a project that requires surveying or surveying related activities to be performed on a highway, or in the vicinity of a highway, and the vehicle is parked on the highway or moving at a speed lower than the normal flow of traffic. The use of, or absence of, amber warning lights as authorized in this section shall not serve as the basis for any civil action, a defense to a civil action, or establish negligence as a matter of law or negligence per se for comparative fault purposes.

Added Stats 1994 ch 207 § 3 (AB 2827), effective July 15, 1994. Amended Stats 1995 ch 91 § 181 (SB 975).

**§ 25279. Warning lights on private security vehicles**

(a) Vehicles owned and operated by private security agencies and utilized exclusively on privately owned and maintained roads to which this code is made applicable by local ordinance or resolution, may display flashing amber warning lights to the front, sides, or rear, while being operated in response to emergency calls for the immediate preservation of life or property.



(b)(1) Vehicles owned by a private security agency and operated by personnel who are registered with the Department of Consumer Affairs under Article 3 (commencing with Section 7582) of Chapter 11.5 of Division 3 of the Business and Professions Code may be equipped with a flashing amber warning light system while the vehicle is operated on a highway, if the vehicle is in compliance with Section 27605 and is distinctively marked with the words "PRIVATE SECURITY" or "SECURITY PATROL" on the rear and both sides of the vehicle in a size that is legible from a distance of not less than 50 feet.

(2) The flashing amber warning light system authorized under paragraph (1) shall not be activated while the vehicle is on the highway, unless otherwise directed by a peace officer, as defined in Chapter 4.5 (commencing with Section 830) of Title 3 of Part 2 of the Penal Code.

(c) A peace officer may order that the flashing amber warning light system of a vehicle that is found to be in violation of this section be immediately removed at the place of business of the vehicle's owner or a garage.

(d) A flashing amber warning light system shall not be installed on a vehicle that has been found to be in violation of this section, unless written authorization is obtained from the Commissioner of the California Highway Patrol.

Added Stats 1979 ch 178 § 1, effective June 29, 1979. Amended Stats 1996 ch 1154 § 76 (AB 3020), effective September 30, 1996.

#### § 25280. Warning lights on garbage collection vehicles

Vehicles operated by a local public entity, or pursuant to a permit, license, contract, or franchise with a local public entity, and used to collect and transport garbage, rubbish, or refuse may display flashing amber warning lights to the front, sides, or rear while stopped upon a street and actually engaged in the collection of garbage, rubbish, or refuse, or while moving between stops at a speed not greater than 10 miles per hour.

Added Stats 1981 ch 280 § 1.

#### § 25281. Display of flashing amber warning lights by privately owned or operated water tender vehicle

A privately owned or operated water tender vehicle, when used exclusively for contract emergency services provided to any public agency, may display flashing amber warning lights to the front, sides, or rear of the vehicle when necessarily parked on a highway or other public road, blocking or partially blocking a highway or other public road, traveling at a speed slower than the normal flow of traffic, or crossing or entering a highway or other public road. The flashing amber lights shall not be displayed when the water tender vehicle is traveling to or from an emergency at the normal speed and flow of traffic, except when the vehicle is traveling in escort with a fire engine or other authorized emergency vehicle. The lights shall be covered with an opaque material when not being displayed.

Added Stats 1994 ch 207 § 4 (AB 2827), effective July 15, 1994.

#### § 25282. Amber warning lights

Any vehicle owned or operated by a contractor or a construction company licensed to operate in this state

pursuant to the Business and Professions Code may display flashing amber warning lights to the front, sides, or rear, if the vehicle is engaged in any phase of a construction project performed on a highway, or in the vicinity of a highway, and the vehicle is parked on the highway or moving at a speed lower than the normal flow of traffic. The use of, or absence of, amber warning lights as authorized in this section shall not serve as the basis for any civil action, a defense to civil action, or establish negligence as a matter of law or negligence per se for comparative fault purposes.

Added Stats 1996 ch 10 § 21 (AB 1869), effective February 9, 1996.

## ARTICLE 8

### Warning Lights and Devices

#### Section

25300. Emergency reflectors

25301. Use of warning devices on utility and public utility vehicles

25305. Use of fuses

#### § 25300. Emergency reflectors

(a) Every vehicle which, if operated during darkness, would be subject to the provisions of Section 25100, and every truck tractor, irrespective of width, shall at all times be equipped with at least three red emergency reflectors. The reflectors need be carried by only one vehicle in a combination.

All reflectors shall be maintained in good working condition.

(b) When any such vehicle is disabled on the roadway during darkness, reflectors of the type specified in subdivision (a) shall be immediately placed as follows:

(1) One at the traffic side of the disabled vehicle, not more than 10 feet to the front or rear thereof;

(2) One at a distance of approximately 100 feet to the rear of the disabled vehicle in the center of the traffic lane occupied by such vehicle; and

(3) One at a distance of approximately 100 feet to the front of the disabled vehicle in the center of the traffic lane occupied by such vehicle.

(4) If disablement of any such vehicle occurs within 500 feet of a curve, crest of a hill, or other obstruction to view, the driver shall so place the reflectors in that direction as to afford ample warning to other users of the highway, but in no case less than 100 nor more than 500 feet from the disabled vehicle.

(5) If disablement of the vehicle occurs upon any roadway of a divided or one-way highway, the driver shall place one reflector at a distance of approximately 200 feet and one such reflector at a distance of approximately 100 feet to the rear of the vehicle in the center of the lane occupied by the stopped vehicle, and one such reflector at the traffic side of the vehicle not more than 10 feet to the rear of the vehicle.

(c) When any such vehicle is disabled or parked off the roadway but within 10 feet thereof during darkness, warning reflectors of the type specified in subdivision (a) shall be immediately placed by the driver as follows: one at a distance of approximately 200 feet and one at a distance of approximately 100 feet to the rear of the vehicle, and one at the traffic side of the vehicle not more than 10 feet to the rear of the vehicle. The reflectors

shall, if possible, be placed between the edge of the roadway and the vehicle, but in no event less than two feet to the left of the widest portion of the vehicle or load thereon.

(d) Until the reflectors required by this section can be placed properly, the requirements of this section may be complied with temporarily by either placing lighted red fuses in the required locations or by use of turn signal lamps, but only if front turn signal lamps at each side are being flashed simultaneously and rear turn signal lamps at each side are being flashed simultaneously.

(e) The reflectors shall be displayed continuously during darkness while the vehicle remains disabled upon the roadway or parked or disabled within 10 feet thereof.

(f) Subdivisions (b), (c), (d), and (e) do not apply to a vehicle under either of the following circumstances:

(1) Parked in a legal position within the corporate limits of any city.

(2) Parked in a legal position upon a roadway bounded by adjacent curbs.

(g) In addition to the reflectors specified in subdivision (a), an emergency warning sign or banner may be attached to a vehicle which is disabled upon the roadway or which is parked or disabled within 10 feet of a roadway.

Enacted Stats 1959 ch 3. Amended Stats 1963 ch 143 § 1; Stats 1965 ch 1125 § 2; Stats 1967 ch 372 § 1; Stats 1977 ch 287 § 6; Stats 1981 ch 774 § 5.

**§ 25301. Use of warning devices on utility and public utility vehicles**

When utility or public utility vehicles are parked, stopped or standing at the site of work as described in Section 22512, warning devices shall be displayed as follows:

(a) During daylight warning devices shall consist of either:

A warning flag or barricade striping on the front and rear of the vehicle.

A warning flag, sign, or barrier on the highway not more than 50 feet in advance of the vehicle and not more than 50 feet to the rear thereof, except that in zones where the speed limit is in excess of 25 miles per hour the 50-foot distance may be increased up to 500 feet from the vehicle as circumstances may warrant.

(b) During darkness the warning devices shall consist of either:

One or more flashing amber warning lights on the vehicle giving warning to approaching traffic from each direction.

A warning light, flare, fusee, or reflector on the highway not more than 50 feet in advance of the vehicle and not more than 50 feet to the rear thereof, except that in zones where the speed limit is in excess of 25 miles per hour the 50-foot distance may be increased up to 500 feet from the vehicle where circumstances may warrant.

(c) The provisions of subdivision (a) or (b) do not prevent the display of both types of the warning devices during daylight or darkness.

(d) During either daylight or darkness, no warning device is necessary if the vehicle is equipped with the flashing warning lights visible to approaching traffic from each direction as provided in subdivision (b).

Enacted Stats 1959 ch 3. Amended Stats 1959 ch 1996 § 33.5; Stats 1961 ch 653 § 41, operative January 1, 1962.

**§ 25305. Use of fusees**

(a) No person shall place, deposit, or display upon or adjacent to any highway any lighted fusee, except as a warning to approaching vehicular traffic or railroad trains, or both, of an existing hazard upon or adjacent to the highway or highway-railroad crossing.

(b) It is unlawful to use any fusee which produces other than a red light. The provisions of this subdivision shall not apply to any railroad, as defined in Section 229 of the Public Utilities Code.

Added Stats 1971 ch 84 § 2.

**ARTICLE 9**

**Commercial and Common Carrier Vehicles**

**Section**

25350. Identification lamps and signs; Passenger common carrier motor vehicle

25351. Identification lamps

25352. Traffic control signal changing devices

25353. Required conditions for equipping public transit buses with illuminated signs

25353.1. (Repealed January 1, 2017) Illuminated advertising signs on City of Santa Monica public transit buses; Definitions

**§ 25350. Identification lamps and signs; Passenger common carrier motor vehicle**

Any passenger common carrier motor vehicle manufactured prior to January 1, 1968, may be equipped with green identification lamps. Any bus may be equipped with an illuminated termini sign, an illuminated identification sign, or any combination thereof, which shall not project any glaring light. Internally illuminated termini signs, identification signs, or any combination thereof, meeting the requirements of Section 25400 may be mounted inside a bus. Any commercial vehicle, other than a passenger common carrier motor vehicle, may be equipped with an illuminated identification sign upon the front thereof which shall not exceed 24 inches in length or 8 inches in width and which emits diffused white light without glare.

Enacted 1959 ch 3. Amended Stats 1963 ch 152 § 1; Stats 1968 ch 980 § 16; Stats 1981 ch 813 § 18.

**§ 25351. Identification lamps**

(a) A commercial vehicle and, except as provided in subdivision (d), any other vehicle 80 or more inches in width may be equipped with identification lamps mounted on the front or rear. No part of any such lamps or their mountings on the front of a motor vehicle shall extend below the top of the windshield.

(b) Identification lamps on such vehicles manufactured prior to January 1, 1968, may exhibit either amber, green, or white light to the front and red light to the rear.

(c) Identification lamps on such vehicles manufactured on or after January 1, 1968, may exhibit only amber light to the front and red light to the rear.

(d) Identification lamps are not permitted on passenger vehicles, except housecars and ambulances, regardless of width.

Enacted 1959 ch 3. Amended Stats 1963 ch 152 § 2; Stats 1968 ch 980 § 17; Stats 1970 ch 422 § 5; Stats 1975 ch 616 § 2, ch 854 § 6.

**§ 25352. Traffic control signal changing devices**

Any bus operated by a publicly owned transit system on regularly scheduled service may be equipped with a device capable of sending a signal that interrupts or changes the sequence patterns of an official traffic control signal, under the following conditions:

(a) If such a device is a flashing gaseous discharge lamp, such lamp shall not emit a visible light exceeding an average of 0.0003 candela per flash of any color measured at a distance of 10 feet.

(b) Such device shall not be installed or used unless and until authorized on specific routes by either the Department of Transportation pursuant to Section 21350 or local authorities pursuant to Section 21351.

(c) Any bus or system operating under the conditions specified herein shall allow emergency vehicles operating pursuant to Section 25258 or 21055 to have priority in changing the sequence patterns of an official traffic control signal.

Added Stats 1977 ch 805 § 2. Amended Stats 1979 ch 723 § 23; Stats 1980 ch 399 § 6, effective July 11, 1980.

**§ 25353. Required conditions for equipping public transit buses with illuminated signs**

(a) Notwithstanding Sections 25400 and 25950, a bus operated by a publicly owned transit system on regularly scheduled service may be equipped with illuminated signs that include destination signs, route-number signs, run-number signs, public service announcement signs, or a combination thereof, visible from any direction of the vehicle, that emit any light color, other than the color red emitted from forward-facing signs, pursuant to the following conditions:

(1) Each illuminated sign shall emit diffused nonglaring light.

(2) Each illuminated sign shall be limited in size to a display area of not greater than 720 square inches.

(3) Each illuminated sign shall not resemble nor be installed in a position that interferes with the visibility or effectiveness of a required lamp, reflector, or other device upon the vehicle.

(4) Each illuminated sign shall display information directly related to public transit service, including, but not limited to, route number, destination description, run number, and public service announcements.

(5) The mixing of individually colored light emitting diode elements, including red, is allowed as long as the emitted color formed by the combination of light emitting diode elements is not red.

(b)(1) An illuminated sign may be operated as a dynamic message sign in a paging or streaming mode.

(2) The following definitions shall govern the construction of paragraph (1):

(A) "Paging," meaning character elements or other information presented for a period of time and then disappearing all at once before the same or new elements are presented, is permitted if the display time of each message is between 2.7 and 10 seconds. Blanking times between each message shall be between 0.5 and 25 seconds.

(B) "Streaming," meaning character elements or other information moving smoothly and continuously across the display, is permitted if the character movement time, from one end of the display to the other, is at least 2.7

seconds, and the movement time of the entire message does not exceed 10 seconds.

(c) A regulation adopted pursuant to this section shall comply with applicable federal law, including, but not limited to, the federal Americans with Disabilities Act of 1990 (42 U.S.C. Sec. 12101 et seq.).

Added Stats 2006 ch 881 § 2 (SB 1726), effective January 1, 2007.

**§ 25353.1. (Repealed January 1, 2017) Illuminated advertising signs on City of Santa Monica public transit buses; Definitions**

(a) Notwithstanding Sections 25400 and 25950, a bus operated by the City of Santa Monica's publicly owned transit system, on regularly scheduled service, in addition to the illuminated signs described in section 25353, may also be equipped with illuminated signs that display advertising and that emit any light color, if all of the following conditions are met:

(1) Each illuminated sign displaying advertising shall emit diffused nonglaring light.

(2) Each illuminated sign displaying advertising shall be limited in size to a display area of not greater than 4,464 square inches.

(3) Each illuminated sign displaying advertising shall not resemble nor be installed in a position that interferes with the visibility or effectiveness of a required lamp, reflector, or other device upon the vehicle.

(4) Each illuminated sign displaying advertising shall only be placed on one or both sides of the vehicle, and shall not be placed in a forward-facing or rear-facing position, and no more than one such sign shall be placed on either side of any single vehicle.

(5) The mixing of individually colored light emitting diode elements, including red, is allowed in each illuminated sign displaying advertising as long as the emitted color formed by the combination of light emitting diode elements is not red.

(b)(1) An illuminated sign displaying advertising may be operated as a dynamic message sign in a paging or streaming mode. However, the electronic message sign display shall remain static while a bus is operating on a freeway as defined in Section 257 of the Streets and Highways Code.

(2) The following definitions shall govern the construction of paragraph (1):

(A) "Paging," meaning character elements or other information presented for a period of time and then disappearing all at once before the same or new elements are presented, is permitted if the display time of each message is between 2.7 and 10 seconds. Blanking times between each message shall be between 0.5 and 25 seconds.

(B) "Streaming," meaning character elements or other information moving smoothly and continuously across the display, is permitted if the character movement time, from one end of the display to the other, is at least 2.7 seconds, and the movement time of the entire message does not exceed 10 seconds.

(c) By July 1, 2016, the City of Santa Monica shall submit to the Legislature and to the department a report on the incidence of adverse impacts on roadway and pedestrian safety due to the utilization of illuminated signs on transit buses displaying advertising pursuant to

this section, if any. The report shall be the product of a collaborative effort by Santa Monica law enforcement and transit officials, other local law enforcement officials in whose jurisdictions Santa Monica transit vehicles operate, and the department.

(d) The City of Santa Monica's publicly owned transit system may, pursuant to subdivision (a), operate up to 25 buses with illuminated signs displaying advertising for two years, after which time the city may increase the number of buses with the signs to up to 30.

(e) This section shall remain in effect only until January 1, 2017, and as of that date is repealed, unless a later enacted statute, that is enacted before January 1, 2017, deletes or extends that date.

Added Stats 2011 ch 529 § 3 (AB 607), effective January 1, 2012, repealed January 1, 2017.

## ARTICLE 10 Diffused Lights

Section  
25400. Lighting requirements  
25401. Diffused lights resembling signs

### § 25400. Lighting requirements

(a) Any vehicle may be equipped with a lamp or device on the exterior of the vehicle that emits a diffused nonglaring light of not more than 0.05 candela per square inch of area.

(b) Any diffused nonglaring light shall not display red to the front, but may display other colors. A diffused nonglaring light shall not resemble nor be installed within 12 inches or in such position as to interfere with the visibility or effectiveness of any required lamp, reflector, or other device upon the vehicle.

(c) A diffused nonglaring lamp or device, other than a display sign authorized by subdivision (d), shall be limited in size to an area of 720 square inches and where any lease, rental, or donation is involved the installation of the lamp or device shall be limited to those vehicles operated either primarily within business or residential districts or municipalities, or between business districts, residential districts, and municipalities in close proximity.

(d) An internally illuminated sign emitting not more than 0.25 candela per square inch and possessing copy which does not contain a white background may be displayed on each side, but not on the front or rear, of a trolley coach or of a bus being operated in urban or suburban service as described in Section 35107 of this code.

Enacted Stats 1959 ch 3. Amended Stats 1963 ch 547 § 5; Stats 1968 ch 144 § 1, ch 582 § 1, effective July 16, 1968.

### § 25401. Diffused lights resembling signs

No diffused nonglaring light on a vehicle shall resemble any official traffic control device.

Enacted Stats 1959 ch 3.

## ARTICLE 11 Acetylene Lamps

Section  
25450. Acetylene lamps

Section  
25451. Motorcycles  
25452. Glaring light

### § 25450. Acetylene lamps

Any motor vehicle, other than a motorcycle, equipped with lighted acetylene headlamps complies with the provisions of this code concerning lighted headlamps when it has two lighted acetylene headlamps of approximately equal candlepower mounted upon the front of the motor vehicle and fitted with clear plane glass front and bright six-inch spherical mirrors and standard acetylene five-eighths or three-quarters foot burners, not more and not less, projecting sufficient light ahead to reveal any vehicle, person or substantial object upon the roadway within 200 feet.

Enacted Stats 1959 ch 3.

### § 25451. Motorcycles

Any motorcycle equipped with one lighted acetylene headlamp complies with the provisions of this code concerning lighted headlamps on motorcycles when the acetylene headlamp is fitted with a clear plane glass front and a bright six-inch spherical mirror and a standard acetylene one-half or five-eighths foot burner, projecting sufficient light ahead to reveal any vehicle, person, or substantial object upon the roadway within a distance of 115 feet.

Enacted Stats 1959 ch 3.

### § 25452. Glaring light

No acetylene lamp shall emit any glaring light.

Enacted Stats 1959 ch 3.

## ARTICLE 12 Reflectorizing Material

Section  
25500. Use of reflectorizing material

### § 25500. Use of reflectorizing material

(a) Area reflectorizing material may be displayed on any vehicle, provided: the color red is not displayed on the front; designs do not tend to distort the length or width of the vehicle; and designs do not resemble official traffic control devices, except that alternate striping resembling a barricade pattern may be used.

No vehicle shall be equipped with area reflectorizing material contrary to these provisions.

(b) The provisions of this section shall not apply to license plate stickers or tabs affixed to license plates as authorized by the Department of Motor Vehicles.

Enacted Stats 1959 ch 3. Amended Stats 1961 ch 58 § 47, effective March 31, 1961, ch 1320 § 1; Stats 1967 ch 106 § 1, effective May 9, 1967; Stats 1970 ch 422 § 6; Stats 1971 ch 1536 § 7.

## ARTICLE 13 Headlamps on Motorcycles and Motor-Driven Cycles

Section  
25650. Headlights on motorcycles

## Section

25650.5. Headlamps on motorcycles manufactured after January 1, 1978; Emergency vehicles  
 25651. Headlamps on motor-driven cycles

**§ 25650. Headlights on motorcycles**

Every motorcycle during darkness shall be equipped with at least one and not more than two lighted headlamps which shall conform to the requirements and limitations of this division.

Enacted Stats 1959 ch 3.

**§ 25650.5. Headlamps on motorcycles manufactured after January 1, 1978; Emergency vehicles**

Every motorcycle manufactured and first registered on and after January 1, 1978, shall be equipped with at least one and not more than two headlamps which automatically turn on when the engine of the motorcycle is started and which remain lighted as long as the engine is running. This section does not preclude equipping motorcycles used as authorized emergency vehicles with a switch to be used to turn off the headlamp during emergency situations or when the light would interfere with law enforcement, if the switch is removed prior to resale of the motorcycle.

Added Stats 1972 ch 201 § 1. Amended Stats 1978 ch 252 § 7, effective June 16, 1978; Stats 1984 ch 247 § 3.

**§ 25651. Headlamps on motor-driven cycles**

The headlamp upon a motor-driven cycle may be of the single-beam or multiple-beam type, but in either event, when the vehicle is operated during darkness, the headlamp shall comply with the requirements and limitations as follows:

(a) The headlamp shall be of sufficient intensity to reveal a person or a vehicle at a distance of not less than 100 feet when the motor-driven cycle is operated at any speed less than 25 miles per hour and at a distance of not less than 200 feet when operated at a speed of 25 to not exceeding 35 miles per hour, and at a distance of 300 feet when operated at a speed greater than 35 miles per hour.

(b) In the event the motor-driven cycle is equipped with a multiple-beam headlamp, the upper beam shall meet the minimum requirements set forth above and the lowermost beam shall meet the requirements applicable to a lowermost distribution of light as set forth in subdivision (b) of Section 24407.

(c) In the event the motor-driven cycle is equipped with a single-beam lamp, it shall be so aimed that when the vehicle is loaded none of the high intensity portion of light, at a distance of 25 feet ahead, shall project higher than the level of the center of the lamp from which it comes.

Enacted Stats 1959 ch 3. Amended Stats 1959 ch 1996 § 35.

**ARTICLE 14****Vehicles Exempted**

## Section

25800. Special mobile equipment  
 25801. Special construction and maintenance equipment  
 25802. Vehicles incidentally operated over highway  
 25803. Lamps on other vehicles operated during darkness  
 25804. Lighting equipment on historical vehicles  
 25805. Lamps on forklift trucks

## Section

25806. Ambulances and firetrucks used for demonstration purposes; Delivery of vehicles to purchaser

**§ 25800. Special mobile equipment**

The provisions of Sections 24012, 24250, 24251, 24400 to 24404, inclusive, and Articles 3 (commencing with Section 24600), 4 (commencing with Section 24800), 5 (commencing with Section 24950), 6 (commencing with Section 25100), 9 (commencing with Section 25350), 11 (commencing with Section 25450), and 13 (commencing with Section 25650), shall not apply to special mobile equipment. Such equipment shall be subject to the provisions of Sections 24254, 25803, and 25950, and Article 12 (commencing with Section 25500).

Enacted Stats 1959 ch 3. Amended Stats 1959 ch 1996 § 36; Stats 1963 ch 2149 § 15; Stats 1972 ch 618 § 147.

**§ 25801. Special construction and maintenance equipment**

The provisions of Sections 24012, 24250, 24251, 24254, 24400 to 24404, inclusive, 24600 to 24604, inclusive, 24606 to 24610, inclusive, Section 25950, and Articles 4 (commencing with Section 24800), 5 (commencing with Section 24950), 6 (commencing with Section 25100), 9 (commencing with Section 25350), 11 (commencing with Section 25450), 12 (commencing with Section 25500), and 13 (commencing with Section 25650) shall not apply to special construction or maintenance equipment, nor to motortrucks equipped with snow removal or sanding devices, but shall apply to motortrucks and automobiles used independently of such equipment.

The provisions of Section 25803 shall be applicable to such equipment.

Enacted 1959 ch 3. Amended Stats 1961 ch 1659 § 9; Stats 1972 ch 618 § 148.

**§ 25802. Vehicles incidentally operated over highway**

Sections 24002, 24005, 24012, 24250, 24251, 24400 to 24404, inclusive, 24600 to 24604, inclusive, 24606 to 24610, inclusive, Article 4 (commencing with Section 24800), Article 5 (commencing with Section 24950), Article 6 (commencing with Section 25100), Article 9 (commencing with Section 25350), Article 11 (commencing with Section 25450), and Article 13 (commencing with Section 25650) of Chapter 2 of this division, Chapter 3 (commencing with Section 26301), Chapter 4 (commencing with Section 26700), and Chapter 5 (commencing with Section 27000) of this division, and Chapter 2 (commencing with Section 29200), Chapter 3 (commencing with Section 29800), Chapter 4 (commencing with Section 30800), and Chapter 5 (commencing with Section 31301) of Division 13 do not apply to logging vehicles or any vehicle of a type subject to registration under this code that is not designed, used, or maintained for the transportation of persons or property and that is operated or moved over a highway only incidentally; but any such vehicle shall be subject to Sections 2800, 2806, 24004, 25260, 25803, 25950, 25952, 26457, 27454, 27602, 31500, and 40150, and to Article 12 (commencing with Section 25500) of Chapter 2 of this division.

Enacted Stats 1959 ch 3. Amended Stats 1961 ch 119 § 1; Stats 1970 ch 923 § 7; Stats 1975 ch 517 § 5; Stats 1979 ch 373 § 326; Stats 1996 ch 124 § 133 (AB 3470).

**§ 25803. Lamps on other vehicles operated during darkness**

(a) All vehicles not otherwise required to be equipped with headlamps, rear lights, or reflectors by this chapter shall, if operated on a highway during darkness, be equipped with a lamp exhibiting a red light visible from a distance of 500 feet to the rear of the vehicle. In addition, all of these vehicles operated alone or as the first vehicle in a combination of vehicles, shall be equipped with at least one lighted lamp exhibiting a white light visible from a distance of 500 feet to the front of the vehicle.

(b) A vehicle shall also be equipped with an amber reflector on the front near the left side and a red reflector on the rear near the left side. The reflectors shall be mounted on the vehicle not lower than 16 inches nor higher than 60 inches above the ground and so designed and maintained as to be visible during darkness from all distances within 500 feet from the vehicle when directly in front of a motor vehicle displaying lawful lighted headlamps undimmed.

(c) In addition, if a vehicle described in subdivision (a) or the load thereon has a total outside width in excess of 100 inches there shall be displayed during darkness at the left outer extremity at least one amber light visible under normal atmospheric conditions from a distance of 500 feet to the front, sides, and rear. At all other times there shall be displayed at the left outer extremity a solid red or fluorescent orange flag or cloth not less than 12 inches square.

Enacted Stats 1959 ch 3. Amended Stats 1959 ch 958 § 1; Stats 1978 ch 252 § 8, effective June 16, 1978; Stats 1998 ch 828 § 21 (SB 1637). Amended Stats 2004 ch 183 § 354 (AB 3082).

**§ 25804. Lighting equipment on historical vehicles**

Notwithstanding any other provision of this code, original lighting equipment installed on a vehicle manufactured prior to January 1, 1946, need not meet the requirements established by the department when the vehicle is used primarily for the purpose of historical exhibition.

Added Stats 1967 ch 594 § 1. Amended 1973 ch 706 § 1; Stats 1979 ch 723 § 24.

**§ 25805. Lamps on forklift trucks**

Notwithstanding any other provision of this article, a forklift truck which is towed upon the highway at the end of a combination of vehicles shall at all times be equipped with at least one stop lamp mounted upon the rear of the vehicle and shall be equipped with lamp-type turn signals. Such vehicle shall, during the hours of darkness, be equipped with at least one taillamp and one red reflector mounted upon the rear of the vehicle and shall be equipped with clearance lamps if the vehicle is 80 or more inches in width.

Added Stats 1969 ch 132 § 1.

**§ 25806. Ambulances and firetrucks used for demonstration purposes; Delivery of vehicles to purchaser**

Sections 24003 and 27002 shall not apply to the installation of warning lamps and sirens on ambulances or firetrucks which are used solely for demonstration

purposes in the sales work of a licensed dealer, distributor, or vehicle manufacturer and shall not apply to ambulances or firetrucks being operated on a highway solely for the purpose of delivery from the licensee to a purchaser. Warning lamps shall be removed or covered with opaque material and the siren controls disabled whenever the vehicle is upon a highway.

Added Stats 1982 ch 217 § 1.

**ARTICLE 15**

**Light Restrictions and Mounting**

Section

25950. Color of lamps and reflectors; Exceptions

25951. Direction of beam

25952. Lamps and reflectors on loads

**§ 25950. Color of lamps and reflectors; Exceptions**

This section applies to the color of lamps and to any reflector exhibiting or reflecting perceptible light of 0.05 candela or more per foot-candle of incident illumination. Unless provided otherwise, the color of lamps and reflectors upon a vehicle shall be as follows:

(a) The emitted light from all lamps and the reflected light from all reflectors, visible from in front of a vehicle, shall be white or yellow, except as follows:

(1) Rear side marker lamps required by Section 25100 may show red to the front.

(2) The color of foglamps described in Section 24403 may be in the color spectrum from white to yellow.

(3) An illuminating device, as permitted under Section 24255, shall emit radiation predominantly in the infrared region of the electromagnetic spectrum. Any incidental visible light projecting to the front of the vehicle shall be predominantly yellow to white. Any incidental visible light projecting to the rear of the vehicle shall be predominantly red. Any incidental visible light from an illuminating device, as permitted under Section 24255, shall not resemble any other required or permitted lighting device or official traffic control device.

(b) The emitted light from all lamps and the reflected light from all reflectors, visible from the rear of a vehicle, shall be red except as follows:

(1) Stoplamps on vehicles manufactured before January 1, 1979, may show yellow to the rear.

(2) Turn signal lamps may show yellow to the rear.

(3) Front side marker lamps required by Section 25100 may show yellow to the rear.

(4) Backup lamps shall show white to the rear.

(5) The rearward facing portion of a front-mounted double-faced turn signal lamp may show amber to the rear while the headlamps or parking lamps are lighted, if the intensity of the light emitted is not greater than the parking lamps and the turn signal function is not impaired.

(6) A reflector meeting the requirements of, and installed in accordance with, Section 24611 shall be red or white, or both.

(c) All lamps and reflectors visible from the front, sides, or rear of a vehicle, except headlamps, may have any unlighted color, provided the emitted light from all

lamps or reflected light from all reflectors complies with the required color. Except for backup lamps, the entire effective projected luminous area of lamps visible from the rear or mounted on the sides near the rear of a vehicle shall be covered by an inner lens of the required color when the unlighted color differs from the required emitted light color. Taillamps, stoplamps, and turn signal lamps that are visible to the rear may be white when unlighted on vehicles manufactured before January 1, 1974.

Added Stats 1979 ch 723 § 24.5. Amended Stats 1980 ch 399 § 7, effective July 11, 1980; Stats 1994 ch 1220 § 66 (AB 3132), effective September 30, 1994; Stats 1995 ch 766 § 38 (SB 726). Amended Stats 2004 ch 198 § 4 (SB 1236).

#### § 25951. Direction of beam

Any lighted lamp or device upon a motor vehicle other than headlamps, spotlamps, signal lamps, or auxiliary driving lamps, warning lamps which projects a beam of light of an intensity greater than 300 candlepower shall be so directed that no part of the beam will strike the level of the roadway at a distance of more than 75 feet from the vehicle.

Enacted 1959 ch 3. Amended Stats 1965 ch 1313 § 12.

#### § 25952. Lamps and reflectors on loads

(a) Lamps, reflectors, and area reflectorizing material of a type required or permitted on a vehicle may be mounted on a load carried by the vehicle in lieu of, or in addition to, such equipment on the vehicle. Such equipment shall be mounted on the load in a manner that would comply with the requirements of this code and regulations adopted pursuant to this code if the load were an integral part of the vehicle.

(b) Lamps on vehicles carried as a load shall not be lighted unless such lamps are mounted in accordance with subdivision (a).

Added Stats 1969 ch 341 § 6.

## ARTICLE 16

### Equipment Testing

#### Section

26100. Safety glazing material

26101. Definitions to govern construction of division

26102. Prospective effect of regulations

26103. Adoption and enforcement of regulations; Federal Motor Vehicle Safety Standard

26104. Requirement of laboratory test data; Proof of compliance

#### § 26100. Safety glazing material

(a) A person shall not sell or offer for sale for use upon or as part of the equipment of a vehicle any lighting equipment, safety glazing material, or other device that does not meet the provisions of Section 26104.

(b) A person shall not use upon a vehicle, and a person shall not drive a vehicle upon a highway that is equipped with, any lighting equipment, safety glazing material, or other device that is not in compliance with Section 26104.

(c) This section does not apply to a taillamp or stop lamp in use on or prior to December 1, 1935.

Added Stats 1979 ch 723 § 26. Amended Stats 2010 ch 491 § 44 (SB 1318), effective January 1, 2011.

#### § 26101. Definitions to govern construction of division

(a) A person shall not sell or offer for sale for use upon or as part of the equipment of a vehicle any device that is intended to modify the original design or performance of any lighting equipment, safety glazing material, or other device, unless the modifying device meets the provisions of Section 26104.

(b) A person shall not use upon a vehicle, and a person shall not drive a vehicle upon a highway that has installed a device that is intended to modify the original design or performance of a lighting, safety glazing material, or other device, unless the modifying device complies with Section 26104.

(c) This section does not apply to a taillamp or stop lamp in use on or prior to December 1, 1935, or to lamps installed on authorized emergency vehicles.

Added Stats 1979 ch 723 § 26. Amended Stats 1997 ch 945 § 26 (AB 1561); Stats 2010 ch 491 § 45 (SB 1318), effective January 1, 2011.

#### § 26102. Prospective effect of regulations

In the event any equipment in actual use meets the requirements of this code or a department regulation adopted pursuant to this code, a subsequent regulation shall not require the replacement of the equipment and shall be applicable only to equipment installed after the effective date of the regulation.

Added Stats 1979 ch 723 § 26.

#### § 26103. Adoption and enforcement of regulations; Federal Motor Vehicle Safety Standard

(a) The department may adopt and enforce regulations establishing standards and specifications for lighting equipment listed in Section 375 and for safety belts, safety glazing material, safety helmets, sirens, tire traction devices, bunk stakes, and synthetic binders. The standards and specifications may include installation and aiming requirements.

(b) If there exists a Federal Motor Vehicle Safety Standard adopted pursuant to the National Traffic and Motor Vehicle Safety Act of 1966 (15 U.S.C. 1381 et seq.) covering the same aspect of performance of a device, the provisions of that standard shall prevail over provisions of this code or regulations adopted pursuant to this code. Lamps, devices, and equipment certified by the manufacturer to meet applicable federal motor vehicle safety standards as original equipment on new vehicles and the identical replacements for those items need not be certified to the department.

Added Stats 1979 ch 723 § 26. Amended Stats 1990 ch 71 § 2 (AB 2498), effective April 30, 1990.

#### § 26104. Requirement of laboratory test data; Proof of compliance

(a) Every manufacturer who sells, offers for sale, or manufactures for use upon a vehicle devices subject to requirements established by the department shall, before the device is offered for sale, have laboratory test data showing compliance with such requirements. Tests may be conducted by the manufacturer.

(b) The department may at any time request from the manufacturer a copy of the test data showing proof of compliance of any device with the requirements established by the department and additional evidence that

due care was exercised in maintaining compliance during production. If the manufacturer fails to provide such proof of compliance within 30 days of notice from the department, the department may prohibit the sale of the device in this state until acceptable proof of compliance is received by the department.

Added Stats 1979 ch 723 § 26. Amended Stats 1980 ch 399 § 8, effective July 11, 1980.

## CHAPTER 3

### Brakes

#### ARTICLE 1

#### Brake Requirements

Section

- 26301. Power brake requirements
- 26301.5. Emergency brake systems
- 26302. Trailers and semitrailers
- 26303. Trailer coaches and camp trailers
- 26304. Breakaway brakes
- 26305. Auxiliary dolly or tow dolly brakes
- 26307. Forklift truck brakes
- 26311. Service brakes on all wheels; Exceptions

**§ 26301. Power brake requirements**

Any motor vehicle first registered in this state after January 1, 1940, shall be equipped with power brakes if its gross weight exceeds 14,000 pounds, except that any such vehicle having a gross weight of less than 18,000 pounds may, in lieu of power brakes, be equipped with two-stage hydraulic actuators of a type designed to increase braking effect of its brakes.

Enacted Stats 1959 ch 3. Amended Stats 1982 ch 789 § 1.

**§ 26301.5. Emergency brake systems**

Every passenger vehicle manufactured and first registered after January 1, 1973, except motorcycles, shall be equipped with an emergency brake system so constructed that rupture or leakage-type failure of any single pressure component of the service brake system, except structural failures of the brake master cylinder body or effectiveness indicator body, shall not result in complete loss of function of the vehicle's brakes when force on the brake pedal is continued.

Added Stats 1971 ch 1110 § 1.

**§ 26302. Trailers and semitrailers**

(a) Every trailer or semitrailer, manufactured and first registered after January 1, 1940, and having a gross weight of 6,000 pounds or more and which is operated at a speed of 20 miles per hour or over shall be equipped with brakes.

(b) Every trailer or semitrailer manufactured and first registered after January 1, 1966, and having a gross weight of 3,000 pounds or more shall be equipped with brakes on at least two wheels.

(c) Every trailer or semitrailer manufactured after January 1, 1982, and equipped with air brakes shall be equipped with brakes on all wheels.

(d) Brakes required on trailers or semitrailers shall be adequate, supplemental to the brakes on the towing vehicle, to enable the combination of vehicles to comply

with the stopping distance requirements of Section 26454.

(e) The provisions of this section shall not apply to any vehicle being used to support the boom or mast attached to a mobile crane or shovel.

Enacted Stats 1959 ch 3. Amended Stats 1965 ch 444 § 1; Stats 1967 ch 373 § 1; Stats 1981 ch 774 § 6.

**§ 26303. Trailer coaches and camp trailers**

Every trailer coach and every camp trailer having a gross weight of 1,500 pounds or more, but exclusive of passengers, shall be equipped with brakes on at least two wheels which are adequate, supplemental to the brakes on the towing vehicle, to enable the combination of vehicles to comply with the stopping distance requirements of Section 26454.

Enacted Stats 1959 ch 3. Amended Stats 1961 ch 409 § 1; Stats 1965 ch 444 § 2; Stats 1971 ch 1536 § 8.

**§ 26304. Breakaway brakes**

(a) Power brakes on any trailer or semitrailer manufactured after December 31, 1955, operated over public highways and required to be equipped with brakes shall be designed to be automatically applied upon breakaway from the towing vehicle and shall be capable of stopping and holding such vehicle stationary for not less than 15 minutes.

(b) Every new truck or truck tractor manufactured after December 31, 1955, operated over public highways and used in towing a vehicle shall be equipped with service brakes capable of stopping the truck or truck tractor in the event of breakaway of the towed vehicle.

Enacted Stats 1959 ch 3. Amended Stats 1963 ch 208 § 1; Stats 1972 ch 733 § 1.

**§ 26305. Auxiliary dolly or tow dolly brakes**

Any auxiliary dolly or tow dolly may be equipped with brakes.

Enacted Stats 1959 ch 3. Amended Stats 1983 ch 708 § 9.

**§ 26307. Forklift truck brakes**

No forklift truck manufactured after January 1, 1970, shall be towed behind another vehicle unless it is equipped with brakes on the wheels of the rearmost axle when the forklift truck is in the towing position, which brakes shall be adequate, supplemental to the brakes on the towing vehicle, to enable the combination of vehicles to comply with the stopping distance requirements of Section 26454.

Added Stats 1969 ch 132 § 2.

**§ 26311. Service brakes on all wheels; Exceptions**

(a) Every motor vehicle shall be equipped with service brakes on all wheels, except as follows:

(1) Trucks and truck tractors manufactured before January 1, 1982, having three or more axles need not have brakes on the front wheels, except when such vehicles are equipped with at least two steerable axles, the wheels of one such axle need not be equipped with brakes.

(2) Any vehicle being towed in a driveaway-towaway operation.

(3) Any vehicle manufactured prior to 1930.



(4) Any two-axle truck tractor manufactured prior to 1964.

(5) Any sidecar attached to a motorcycle.

(6) Any motorcycle manufactured prior to 1966. Such motorcycle shall be equipped with brakes on at least one wheel.

(b) Any bus, truck, or truck tractor may be equipped with a manual or automatic means for reducing the braking effort on the front wheels. The manual means shall be used only when operating under adverse road conditions, such as wet, snowy, or icy roads.

(c) Vehicles and combinations of vehicles exempted in subdivisions (a) and (b) from the requirements of brakes on all wheels shall comply with the stopping distance requirements of Section 26454.

Added Stats 1963 ch 208 § 2. Amended Stats 1965 ch 439 § 2; Stats 1981 ch 774 § 7.

## ARTICLE 2

### Operation of Brakes

#### Section

- 26450. Service brake and parking brake systems
- 26451. Parking brake requirements
- 26452. Brakes after engine failure
- 26453. Condition of brakes
- 26454. Control and stopping requirements
- 26455. Determination of vehicle weight
- 26456. Stopping tests
- 26457. Exemptions
- 26458. Brake requirements for towing vehicles
- 26458.5. Use of additional control

#### § 26450. Service brake and parking brake systems

Every motor vehicle shall be equipped with a service brake system and every motor vehicle, other than a motorcycle, shall be equipped with a parking brake system. Both the service brake and parking brake shall be separately applied.

If the two systems are connected in any way, they shall be so constructed that failure of any one part, except failure in the drums, brakeshoes, or other mechanical parts of the wheel brake assemblies, shall not leave the motor vehicle without operative brakes.

Enacted Stats 1959 ch 3. Amended Stats 1963 ch 208 § 3; Stats 1965 ch 443 § 2; Stats 1967 ch 369 § 1.

#### § 26451. Parking brake requirements

The parking brake system of every motor vehicle shall comply with the following requirements:

(a) The parking brake shall be adequate to hold the vehicle or combination of vehicles stationary on any grade on which it is operated under all conditions of loading on a surface free from snow, ice or loose material. In any event the parking brake shall be capable of locking the braked wheels to the limit of traction.

(b) The parking brake shall be applied either by the driver's muscular efforts, by spring action, or by other energy which is isolated and used exclusively for the operation of the parking brake or the combination parking brake and emergency stopping system.

(c) The parking brake shall be held in the applied position solely by mechanical means.

Enacted Stats 1959 ch 3. Amended Stats 1963 ch 208 § 4; Stats 1965 ch 443 § 3; Stats 1967 ch 1427 § 1; Stats 1981 ch 774 § 8.

#### § 26452. Brakes after engine failure

All motor vehicles shall be so equipped as to permit application of the brakes at least once for the purpose of bringing the vehicle to a stop within the legal stopping distance after the engine has become inoperative.

Enacted 1959 ch 3.

#### § 26453. Condition of brakes

All brakes and component parts thereof shall be maintained in good condition and in good working order. The brakes shall be so adjusted as to operate as equally as practicable with respect to the wheels on opposite sides of the vehicle.

Enacted Stats 1959 ch 3. Amended Stats 1959 ch 675 § 1, ch 2183 § 1.

#### § 26454. Control and stopping requirements

(a) The service brakes of every motor vehicle or combination of vehicles shall be adequate to control the movement of and to stop and hold such vehicle or combination of vehicles under all conditions of loading on any grade on which it is operated.

(b) Every motor vehicle or combination of vehicles, at any time and under all conditions of loading, shall, upon application of the service brake, be capable of stopping from an initial speed of 20 miles per hour according to the following requirements:

	Maximum Stopping Distance (feet)
(1) Any passenger vehicle .....	25
(2) Any single motor vehicle with a manufacturer's gross vehicle weight rating of less than 10,000 lbs .....	30
(3) Any combination of vehicles consisting of a passenger vehicle or any motor vehicle with a manufacturer's gross vehicle weight rating of less than 10,000 lbs. in combination with any trailer, semitrailer or trailer coach .....	40
(4) Any single motor vehicle with a manufacturer's gross vehicle weight rating of 10,000 lbs. or more or any bus .....	40
(5) All other combinations of vehicles .....	50

Enacted Stats 1959 ch 3. Amended Stats 1965 ch 443 § 4.

#### § 26455. Determination of vehicle weight

In respect to any motor vehicle designed, used or maintained primarily for the transportation of property which is not equipped with a plate or marker showing the manufacturer's gross vehicle weight rating, for purposes of stopping distance requirements, the weight of a vehicle shall be determined as follows:

(a) Any motor vehicle having less than six wheels is the equivalent of a vehicle having a manufacturer's gross vehicle weight rating of less than 10,000 pounds.

(b) Any motor vehicle having six wheels or more is the equivalent of a vehicle having a manufacturer's gross vehicle weight rating of 10,000 pounds or more.

Enacted Stats 1959 ch 3.

**§ 26456. Stopping tests**

Stopping distance requirement tests shall be conducted on a substantially level, dry, smooth, hard-surfaced road that is free from loose material and where the grade does not exceed plus or minus 1 percent. Stopping distance shall be measured from the instant brake controls are moved and from an initial speed of approximately 20 miles per hour. No test of brake performance shall be made upon a highway at a speed in excess of 25 miles per hour.

Enacted Stats 1959 ch 3.

**§ 26457. Exemptions**

Special mobile equipment, logging vehicles, equipment operated under special permit, and any chassis without body or load are not subject to stopping distance requirements, but if any such vehicle or equipment cannot be stopped within 32 feet from an initial speed of 15 miles per hours, it shall not be operated at a speed in excess of that permitting a stop in 32 feet.

Enacted Stats 1959 ch 3. Amended Stats 1963 ch 2149 § 17; Stats 1975 ch 517 § 6.

**§ 26458. Brake requirements for towing vehicles**

(a) The braking system on every motor vehicle used to tow another vehicle shall be so arranged that one control on the towing vehicle shall, when applied, operate all the service brakes on the power unit and combination of vehicles when either or both of the following conditions exist:

(1) The towing vehicle is required to be equipped with power brakes.

(2) The towed vehicle is required to be equipped with brakes and is equipped with power brakes.

(b) Subdivision (a) shall not be construed to prohibit motor vehicles from being equipped with an additional control to be used to operate the brakes on the trailer or trailers.

(c) Subdivision (a) does not apply to any of the following combinations of vehicles, if the combination of vehicles meets the stopping distance requirements of Section 26454:

(1) Vehicles engaged in driveaway-towaway operations.

(2) Disabled vehicles, while being towed.

(3) Towed motor vehicles.

(4) Trailers equipped with inertially controlled brakes which are designed to be applied automatically upon breakaway from the towing vehicle and which are capable of stopping and holding the trailer stationary for not less than 15 minutes.

Added Stats 1963 ch 207 § 2. Amended Stats 1965 ch 186 § 2; Stats 1975 ch 397 § 1; Stats 1991 ch 121 § 1 (AB 430).

**§ 26458.5. Use of additional control**

Pursuant to Section 26458, whenever a motor vehicle is equipped with an additional control to operate the brakes on a trailer, that control shall not be used in lieu of the service brake control, except in the case of failure of the service brake system.

Added Stats 1989 ch 316 § 1.

**ARTICLE 3**

**Airbrakes**

Section

26502. Adjustment and use of special devices

26503. Safety valve

26504. Air governor

26505. Pressure gauge

26506. Warning device

26507. Check valve

26508. Emergency stopping system

**§ 26502. Adjustment and use of special devices**

(a) Airbrakes of every motor vehicle and combination of vehicles shall be so adjusted and maintained as to be capable of providing full service brake application at all times except as provided in subdivision (b) of Section 26311. A full service brake application shall deliver to all brake chambers not less than 90 percent of the air reservoir pressure remaining with the brakes applied.

(b) The department may by regulation authorize the use of special devices or systems to automatically reduce the maximum air pressure delivered to the brake chambers in order to compensate for load variation and to obtain balanced braking. Permitted systems shall be of the fail safe type and shall not increase the vehicle stopping distance.

Added Stats 1965 ch 1789 § 2.

**§ 26503. Safety valve**

Every motor vehicle equipped with airbrakes or equipped to operate airbrakes on towed vehicles shall be equipped with a standard type safety valve which shall be installed so as to have an uninterrupted connection with the air reservoir or tank. It shall be adjusted and maintained so that it will open and discharge the air system under any condition at a pressure of not to exceed 150 pounds per square inch and close and reset itself at a point above the maximum air governor setting. The department may by regulation prescribe a higher maximum opening pressure for air pressure systems designed for, and capable of safely operating with, pressure safety valves with a higher opening pressure.

Added Stats 1959 ch 455 § 1. Amended Stats 1963 ch 204 § 4; Stats 1965 ch 186 § 3; Stats 1967 ch 1578 § 1.

**§ 26504. Air governor**

The air governor cut-in and cut-out pressures of every motor vehicle equipped with airbrakes or equipped to operate airbrakes on towed vehicles shall be adjusted so that the maximum pressure in the air system and the minimum cut-in pressure shall be within limits prescribed by the department. In adopting regulations specifying such pressures the department shall consider the safe operating capacities of the various airbrake systems which are now or may be used on motor vehicles and shall be guided by the designed capabilities of those systems.

Added Stats 1959 ch 740 § 1. Amended Stats 1967 ch 1578 § 2.

**§ 26505. Pressure gauge**

A motor vehicle equipped with airbrakes or equipped to operate airbrakes on towed vehicles shall be equipped with a pressure gauge of reliable and satisfactory con-

struction and maintained in an efficient working condition, accurate within 10 percent of the actual air reservoir pressure, and visible and legible to a person when seated in the driving position.

Added Stats 1959 ch 454 § 1, operative January 1, 1960. Amended Stats 1961 ch 48 § 1; Stats 1967 ch 1578 § 3; Stats 2010 ch 491 § 46 (SB 1318), effective January 1, 2011.

#### § 26506. Warning device

(a) Every motor vehicle airbrake system used to operate the brakes on a motor vehicle or on a towed vehicle shall be equipped with a low air pressure warning device that complies with either the requirements set forth in the Federal Motor Vehicle Safety Standards in effect at the time of manufacture or the requirements of subdivision (b).

(b) The device shall be readily visible or audible to the driver and shall give a satisfactory continuous warning when the air supply pressure drops below a fixed pressure, which shall be not more than 75 pounds per square inch nor less than 55 pounds per square inch with the engine running. A gauge indicating pressure shall not satisfy this requirement.

Added Stats 1959 ch 419 § 1, operative January 1, 1960. Amended Stats 1965 ch 440 § 1; Stats 1992 ch 1241 § 25 (SB 1615).

#### § 26507. Check valve

A check valve shall be installed and properly maintained in the air supply piping of every motor vehicle equipped with airbrakes, either between the air compressor and the first reservoir or tank immediately adjacent to the air intake of said reservoir, or between No. 1 reservoir (wet tank) and No. 2 reservoir (dry tank) immediately adjacent to the air intake of the No. 2 reservoir; provided, that the air supply for the brakes is not drawn from the No. 1 reservoir and that the No. 1 and No. 2 reservoirs are connected by only one pipeline.

Added Stats 1959 ch 510 § 2.

#### § 26508. Emergency stopping system

Every vehicle or combination of vehicles using compressed air at the wheels for applying the service brakes shall be equipped with an emergency stopping system meeting the requirements of this section and capable of stopping the vehicle or combination of vehicles in the event of failure in the service brake air system as follows:

(a) Every motor vehicle operated either singly or in a combination of vehicles and every towed vehicle shall be equipped with an emergency stopping system.

(b) Motor vehicles used to tow vehicles which use compressed air at the wheels for applying the service brakes shall be equipped with a device or devices with both a manual and automatic means of actuating the emergency stopping system on the towed vehicle as follows:

(1) The automatic device shall operate automatically in the event of reduction of the service brake air supply of the towing vehicle to a fixed pressure which shall be not lower than 20 pounds per square inch nor higher than 45 pounds per square inch.

(2) The manual device shall be readily operable by a person seated in the driver's seat, with its emergency position or method of operation clearly indicated. In no instance may the manual means be so arranged as to

permit its use to prevent operation of the automatic means.

(c) Motor vehicles manufactured prior to 1964 shall be deemed to be in compliance with subdivisions (e) and (f) when equipped with axle-by-axle protected airbrakes using a separate air tank system for each of at least two axles, provided that each system independently meets all other requirements of this section. Each system shall be capable of being manually applied, released, and reapplied from the driver's seat but shall not be capable of being released from the driver's seat after any reaplication unless there is available a means which can be applied from the driver's seat to stop and hold the vehicle or combination of vehicles.

(d) Towed vehicles shall be deemed to be in compliance with this section when:

(1) The towed vehicle is equipped with a no-bleed-back relay-emergency valve or equivalent device, so designed that the supply reservoir used to provide air for the brakes is safeguarded against backflow of air from the reservoir through the supply line,

(2) The brakes are applied automatically and promptly upon breakaway from the towing vehicle and maintain application for at least 15 minutes, and

(3) The combination of vehicles is capable of stopping within the distance and under the conditions specified in subdivisions (k) and (l).

(e) If the service brake system and the emergency stopping system are connected in any way, they shall be so constructed that a failure or malfunction in any one part of either system, including brake chamber diaphragm failure but not including failure in the drums, brakeshoes, or other mechanical parts of the wheel brake assemblies, shall not leave the vehicle without one operative stopping system capable of complying with the performance requirements in subdivision (k).

(f) Every emergency stopping system shall be designed so that it is capable of being manually applied, released, and reapplied by a person seated in the driver's seat. The system shall be designed so that it cannot be released from the driver's seat after any reaplication unless immediate further application can be made from the driver's seat to stop and hold the vehicle or combination of vehicles. The emergency stopping system may also be applied automatically.

(g) No vehicle or combination of vehicles upon failure of the service brake air system shall be driven on a highway under its own power except to the extent necessary to move the vehicles off the roadway to the nearest place of safety.

(h) No vehicle or combination of vehicles shall be equipped with an emergency stopping system that creates a hazard on the highway, or increases the service brake stopping distance of a vehicle or combination of vehicles, or interferes in any way with the application of the service brakes on any vehicle or combination of vehicles.

(i) Any energy-storing device which is a part of the emergency stopping system shall be designed so that it is recharged or reset from the source of compressed air or other energy produced by the vehicle, except that energy to release the emergency stopping system may be produced by the driver's muscular effort from the driver's seat. No device shall be used which can be set to prevent

automatic delivery of air to protected air supply reservoirs of motor vehicle emergency stopping systems when air is available in the service brake air supply system.

(j) Any vehicle manufactured on or after January 1, 1964, which uses axle-by-axle protected airbrakes as the emergency stopping system shall use a separate air tank system for each axle, except that motor vehicles equipped with a dual or tandem treadle valve system need have no more than two protected air tanks in such system, one for each valve.

(k) Every motor vehicle or combination of vehicles, at all times and under all conditions of loading, upon application of the emergency stopping system, shall be capable of:

(1) Developing a stopping force that is not less than the percentage of its gross weight tabulated herein for its classification.

(2) Decelerating in a stop from 20 miles per hour at not less than the feet per second per second tabulated herein for its classification, and

(3) Stopping from a speed of 20 miles per hour in not more than the distance tabulated herein for its classification, such distance to be measured from the point at which movement of the emergency stopping system control begins.

EMERGENCY STOPPING SYSTEM REQUIREMENTS

Classification of vehicle and combination of vehicles	Stopping force as a percentage of gross vehicle or combination weight	Deceleration in feet per second	Stopping distance in feet
A Single-motor vehicles .....	16.7	5.5	90
B Combination of vehicles .....	19.0	6.0	90
C Single-motor vehicle with 3 or more axles manufactured prior to 1964 ..	12.1	4.0	120

(l) Tests for deceleration and stopping distance shall be made on a substantially level, dry, smooth, hard surface that is free from loose material and where the grade does not exceed plus or minus 1 percent. No test of emergency stopping system performance shall be made upon a highway at a speed in excess of 25 miles per hour.

(m) The provisions of this section shall not apply to:

(1) Auxiliary dollies, special mobile equipment, or special construction equipment.

(2) Motor vehicles which are operated in a driveway-towaway operation and not registered in this state.

(3) Disabled vehicles when being towed.

(4) Vehicles which are operated under a one-trip permit as provided in Section 4003.

(5) Vehicles which because of unladen width, length, height or weight may not be moved upon the highway without the permit specified in Section 35780.

(n) The emergency stopping system requirements specified in subdivision (k) shall not apply to a vehicle or combination of vehicles being operated under a special weight permit nor to any overweight authorized emergency vehicle operated under the provisions of Section 35002.

(o) Every owner or lessee shall instruct and require that the driver be thoroughly familiar with the require-

ments of this section. The driver of a vehicle or combination of vehicles required to comply with the requirements of this section shall be able to demonstrate the application and release of the emergency system on the vehicle and each vehicle in the combination.

Added Stats 1964 ch 496 § 2. Amended Stats 1965 ch 594 § 1; Stats 1967 ch 1578 § 4.

## ARTICLE 4

### Vacuum Brakes

- Section
- 26520. Vacuum gauge
- 26521. Warning device
- 26522. Check valve

#### § 26520. Vacuum gauge

Motor vehicles required to be equipped with power brakes and which are equipped with vacuum or vacuum-assisted brakes shall be equipped with a properly maintained vacuum gauge of reliable and satisfactory construction, accurate within 10 percent of the actual vacuum in the supply reservoir, and visible and legible to the driver at all times.

This section shall not apply to a two-axle motor truck operated singly.

Added Stats 1963 ch 386 § 1.

#### § 26521. Warning device

Motor vehicles required to be equipped with power brakes and equipped with vacuum or vacuum-assisted brakes and motor vehicles used to tow vehicles equipped with vacuum brakes or vacuum-assisted brakes shall be equipped with either an audible or visible warning signal to indicate readily to the driver when the vacuum drops to eight inches of mercury and less. A vacuum gauge shall not be deemed to meet this requirement.

This section shall not apply to a two-axle motor truck operated singly nor to any motor vehicle manufactured prior to 1964.

Added Stats 1963 ch 386 § 1.

#### § 26522. Check valve

Vehicles required to be equipped with power brakes and equipped with vacuum or vacuum-assisted brakes shall have a check valve installed and properly maintained in the vacuum system between the source of vacuum and the vacuum reserve.

Added Stats 1963 ch 386 § 1.

## CHAPTER 4

### Windshields and Mirrors

- Section
- 26700. Windshields
- 26701. Safety glazing material
- 26703. Replacement of glazing material
- 26704. "Safety glazing material"
- 26705. Motorcycle windshields
- 26706. Windshield wipers
- 26707. Condition and use of windshield wipers
- 26708. Material obstructing or reducing driver's view; Exceptions
- 26708.2. Sun screening devices
- 26708.5. Transparent materials; Tinted safety glass

## Section

26708.7. Vehicle used by peace officers in performance of duties; Use of window tinting or glazing

26709. Mirrors

26710. Defective windshields and rear windows

26711. Eyeshades for bus or trolley operators

26712. Defroster required

### § 26700. Windshields

(a) Except as provided in subdivision (b), a passenger vehicle, other than a motorcycle, and every bus, motor-truck or truck tractor, and every firetruck, fire engine or other fire apparatus, whether publicly or privately owned, shall be equipped with an adequate windshield.

(b) Subdivision (a) does not apply to any vehicle issued identification plates pursuant to Section 5004 which was not required to be equipped with a windshield at the time it was first sold or registered under the laws of this state, another state, or foreign jurisdiction.

Enacted Stats 1959 ch 3. Amended Stats 1959 ch 1635 § 1; Stats 1963 ch 2149 § 18; Stats 1967 ch 379 § 1; Stats 1983 ch 222 § 1.

### § 26701. Safety glazing material

(a) No person shall sell, offer for sale, or operate any motor vehicle, except a motorcycle, manufactured after January 1, 1936, unless it is equipped with safety glazing material wherever glazing materials are used in interior partitions, doors, windows, windshields, auxiliary wind deflectors or openings in the roof.

(b) No person shall sell or offer for sale any camper manufactured after January 1, 1968, nor shall any person operate a motor vehicle registered in this state which is equipped with that camper, unless the camper is equipped with safety glazing materials wherever glazing materials are used in outside windows and doors, interior partitions, and openings in the roof.

(c) No person shall operate a motorcycle manufactured after January 1, 1969, equipped with a windshield containing glazing material unless it is safety glazing material.

(d) No person shall sell, offer for sale, or operate any motor vehicle equipped with red, blue, or amber translucent aftermarket material in any partitions, windows, windshields, or wind deflectors.

(e) No person shall sell, offer for sale, or operate any trailer coach manufactured after January 1, 1977, that is capable of being towed with a fifth-wheel device unless the trailer coach is equipped with safety glazing materials wherever glazing materials are used in windows or doors, interior partitions, and openings in the roof.

Enacted Stats 1959 ch 3. Amended Stats 1965 ch 335 § 1; Stats 1967 ch 1268 § 3; Stats 1968 ch 980 § 20, ch 1469 § 5; Stats 1976 ch 900 § 2; Stats 1993 ch 540 § 2 (AB 1849).

### § 26703. Replacement of glazing material

(a) No person shall replace any glazing materials used in interior partitions, doors, windows, or openings in the roof in any motor vehicle, in the outside windows, doors, interior partitions, or openings in the roof of any camper, or in windows, doors, interior partitions, or openings in the roof of a trailer coach capable of being towed with a fifth-wheel device, with any glazing material other than safety glazing material.

(b) No person shall replace any glazing material used in the windshield, rear window, auxiliary wind deflec-

tors, or windows to the left and right of the driver with any material other than safety glazing material.

Enacted Stats 1959 ch 3. Amended Stats 1965 ch 335 § 1; Stats 1967 ch 1268 § 5; Stats 1968 ch 980 § 21; Stats 1976 ch 900 § 3.

### § 26704. "Safety glazing material"

Wherever the term "safety glazing material" is used in this article, it means safety glazing material of a type meeting requirements established by the department.

Added Stats 1979 ch 723 § 28.

### § 26705. Motorcycle windshields

On or after January 1, 1969, no person shall sell or offer for sale for use upon or as part of the equipment of a motorcycle any motorcycle windshield unless the glazing material used therein is safety glazing material.

Added Stats 1968 ch 980 § 21.6, ch 1469 § 7.

### § 26706. Windshield wipers

(a) Every motor vehicle, except motorcycles, equipped with a windshield shall also be equipped with a self-operating windshield wiper.

(b) Every new motor vehicle first registered after December 31, 1949, except motorcycles, shall be equipped with two such windshield wipers, one mounted on the right half and one on the left half of the windshield, except that any motor vehicle may be equipped with a single wiper so long as it meets the wiped area requirements in Federal Motor Vehicle Safety Standards Governing Windshield Wiping and Washing Systems.

(c) This section does not apply to snow removal equipment equipped with adequate manually operated windshield wipers.

Enacted Stats 1959 ch 3. Amended Stats 1959 ch 1635 § 2; Stats 1963 ch 2149 § 19; Stats 1978 ch 196 § 1.

### § 26707. Condition and use of windshield wipers

Windshield wipers required by this code shall be maintained in good operating condition and shall provide clear vision through the windshield for the driver. Wipers shall be operated under conditions of fog, snow, or rain and shall be capable of effectively clearing the windshield under all ordinary storm or load conditions while the vehicle is in operation.

Enacted Stats 1959 ch 3.

### § 26708. Material obstructing or reducing driver's view; Exceptions

(a)(1) A person shall not drive any motor vehicle with any object or material placed, displayed, installed, affixed, or applied upon the windshield or side or rear windows.

(2) A person shall not drive any motor vehicle with any object or material placed, displayed, installed, affixed, or applied in or upon the vehicle that obstructs or reduces the driver's clear view through the windshield or side windows.

(3) This subdivision applies to a person driving a motor vehicle with the driver's clear vision through the windshield, or side or rear windows, obstructed by snow or ice.

(b) This section does not apply to any of the following:

- (1) Rearview mirrors.

(2) Adjustable nontransparent sunvisors that are mounted forward of the side windows and are not attached to the glass.

(3) Signs, stickers, or other materials that are displayed in a seven-inch square in the lower corner of the windshield farthest removed from the driver, signs, stickers, or other materials that are displayed in a seven-inch square in the lower corner of the rear window farthest removed from the driver, or signs, stickers, or other materials that are displayed in a five-inch square in the lower corner of the windshield nearest the driver.

(4) Side windows that are to the rear of the driver.

(5) Direction, destination, or terminus signs upon a passenger common carrier motor vehicle or a schoolbus, if those signs do not interfere with the driver's clear view of approaching traffic.

(6) Rear window wiper motor.

(7) Rear trunk lid handle or hinges.

(8) The rear window or windows, if the motor vehicle is equipped with outside mirrors on both the left- and right-hand sides of the vehicle that are so located as to reflect to the driver a view of the highway through each mirror for a distance of at least 200 feet to the rear of the vehicle.

(9) A clear, transparent lens affixed to the side window opposite the driver on a vehicle greater than 80 inches in width and that occupies an area not exceeding 50 square inches of the lowest corner toward the rear of that window and that provides the driver with a wide-angle view through the lens.

(10) Sun screening devices meeting the requirements of Section 26708.2 installed on the side windows on either side of the vehicle's front seat, if the driver or a passenger in the front seat has in his or her possession a letter or other document signed by a licensed physician and surgeon certifying that the person must be shaded from the sun due to a medical condition, or has in his or her possession a letter or other document signed by a licensed optometrist certifying that the person must be shaded from the sun due to a visual condition. The devices authorized by this paragraph shall not be used during darkness.

(11) An electronic communication device affixed to the center uppermost portion of the interior of a windshield within an area that is not greater than five inches square, if the device provides either of the following:

(A) The capability for enforcement facilities of the Department of the California Highway Patrol to communicate with a vehicle equipped with the device.

(B) The capability for electronic toll and traffic management on public or private roads or facilities.

(12) A portable Global Positioning System (GPS), which may be mounted in a seven-inch square in the lower corner of the windshield farthest removed from the driver or in a five-inch square in the lower corner of the windshield nearest to the driver and outside of an airbag deployment zone, if the system is used only for door-to-door navigation while the motor vehicle is being operated.

(13)(A) A video event recorder with the capability of monitoring driver performance to improve driver safety, which may be mounted in a seven-inch square in the lower corner of the windshield farthest removed from the driver, in a five-inch square in the lower corner of the

windshield nearest to the driver and outside of an airbag deployment zone, or in a five-inch square mounted to the center uppermost portion of the interior of the windshield. As used in this section, "video event recorder" means a video recorder that continuously records in a digital loop, recording audio, video, and G-force levels, but saves video only when triggered by an unusual motion or crash or when operated by the driver to monitor driver performance.

(B) A vehicle equipped with a video event recorder shall have a notice posted in a visible location which states that a passenger's conversation may be recorded.

(C) Video event recorders shall store no more than 30 seconds before and after a triggering event.

(D) The registered owner or lessee of the vehicle may disable the device.

(E) The data recorded to the device is the property of the registered owner or lessee of the vehicle.

(F) When a person is driving for hire as an employee in a vehicle with a video event recorder, the person's employer shall provide unedited copies of the recordings upon the request of the employee or the employee's representative. These copies shall be provided free of charge to the employee and within five days of the request.

(14)(A) A video event recorder in a commercial motor vehicle with the capability of monitoring driver performance to improve driver safety, which may be mounted no more than two inches below the upper edge of the area swept by the windshield wipers, and outside the driver's sight lines to the road and highway signs and signals. Subparagraphs (B) to (F), inclusive, of paragraph (13) apply to the exemption provided by this paragraph.

(B) Except as provided in subparagraph (C), subparagraph (A) shall become inoperative on the following dates, whichever date is later:

(i) The date that the Department of the California Highway Patrol determines is the expiration date of the exemption from the requirements of paragraph (1) of subdivision (e) of Section 393.60 of Title 49 of the Code of Federal Regulations, as renewed in the notice of the Federal Motor Carrier Safety Administration on pages 21791 and 21792 of Volume 76 of the Federal Register (April 18, 2011).

(ii) The date that the Department of the California Highway Patrol determines is the expiration date for a subsequent renewal of an exemption specified in clause (i).

(C) Notwithstanding subparagraph (B), subparagraph (A) shall become operative on the date that the Department of the California Highway Patrol determines is the effective date of regulations revising paragraph (1) of subdivision (e) of Section 393.60 of Title 49 of the Code of Federal Regulations to allow the placement of a video event recorder at the top of the windshield on a commercial motor vehicle.

(c) Notwithstanding subdivision (a), transparent material may be installed, affixed, or applied to the topmost portion of the windshield if the following conditions apply:

(1) The bottom edge of the material is at least 29 inches above the undepressed driver's seat when measured from a point five inches in front of the bottom of

the backrest with the driver's seat in its rearmost and lowest position with the vehicle on a level surface.

(2) The material is not red or amber in color.

(3) There is no opaque lettering on the material and any other lettering does not affect primary colors or distort vision through the windshield.

(4) The material does not reflect sunlight or headlight glare into the eyes of occupants of oncoming or following vehicles to any greater extent than the windshield without the material.

(d) Notwithstanding subdivision (a), clear, colorless, and transparent material may be installed, affixed, or applied to the front side windows, located to the immediate left and right of the front seat if the following conditions are met:

(1) The material has a minimum visible light transmittance of 88 percent.

(2) The window glazing with the material applied meets all requirements of Federal Motor Vehicle Safety Standard No. 205 (49 C.F.R. 571.205), including the specified minimum light transmittance of 70 percent and the abrasion resistance of AS-14 glazing, as specified in that federal standard.

(3) The material is designed and manufactured to enhance the ability of the existing window glass to block the sun's harmful ultraviolet A rays.

(4) The driver has in his or her possession, or within the vehicle, a certificate signed by the installing company certifying that the windows with the material installed meet the requirements of this subdivision and the certificate identifies the installing company and the material's manufacturer by full name and street address, or, if the material was installed by the vehicle owner, a certificate signed by the material's manufacturer certifying that the windows with the material installed according to manufacturer's instructions meet the requirements of this subdivision and the certificate identifies the material's manufacturer by full name and street address.

(5) If the material described in this subdivision tears or bubbles, or is otherwise worn to prohibit clear vision, it shall be removed or replaced.

Enacted Stats 1959 ch 3. Amended Stats 1961 ch 1196 § 1; Stats 1965 ch 2031 § 12, effective July 23, 1965; Stats 1967 ch 546 § 1; Stats 1968 ch 178 § 2; 1972 ch 528 § 1; Stats 1976 ch 843 § 3; Stats 1978 ch 222 § 1, ch 500 § 2; Stats 1981 ch 770 § 1; Stats 1982 ch 635 § 1; Stats 1983 ch 632 § 1; Stats 1984 ch 74 § 1; Stats 1987 ch 552 § 1; Stats 1989 ch 533 § 13; Stats 1996 ch 1154 § 77 (AB 3020), effective September 30, 1996; Stats 1998 ch 476 § 1 (AB 2320); Stats 2008 ch 413 § 1 (SB 1567), effective January 1, 2009; Stats 2009 ch 140 § 181 (AB 1164), effective January 1, 2010; Stats 2010 ch 458 § 1 (AB 1942), effective January 1, 2011; Stats 2012 ch 375 § 2 (AB 2477), effective January 1, 2013.

#### § 26708.2. Sun screening devices

Sun screening devices permitted by paragraph (10) of subdivision (b) of Section 26708 shall meet the following requirements:

(a) The devices shall be held in place by means allowing ready removal from the window area, such as a frame, a rigid material with temporary fasteners, or a flexible roller shade.

(b) Devices utilizing transparent material shall be green, gray, or a neutral smoke in color and shall have a luminous transmittance of not less than 35 percent.

(c) Devices utilizing nontransparent louvers or other alternating patterns of opaque and open sections shall

have an essentially uniform pattern over the entire surface, except for framing and supports. At least 35 percent of the device area shall be open and no individual louver or opaque section shall have a projected vertical dimension exceeding  $\frac{3}{16}$  inch.

(d) The devices shall not have a reflective quality exceeding 35 percent on either the inner or outer surface.

Added Stats 1984 ch 74 § 2.

#### § 26708.5. Transparent materials; Tinted safety glass

(a) No person shall place, install, affix, or apply any transparent material upon the windshield, or side or rear windows, of any motor vehicle if the material alters the color or reduces the light transmittance of the windshield or side or rear windows, except as provided in subdivision (b), (c), or (d) of Section 26708.

(b) Tinted safety glass may be installed in a vehicle if (1) the glass complies with motor vehicle safety standards of the United States Department of Transportation for safety glazing materials, and (2) the glass is installed in a location permitted by those standards for the particular type of glass used.

Added Stats 1972 ch 528 § 2. Amended Stats 1981 ch 714 § 447; Stats 1984 ch 210 § 1; Stats 1998 ch 476 § 2 (AB 2320).

#### § 26708.7. Vehicle used by peace officers in performance of duties; Use of window tinting or glazing

Notwithstanding any other law, a vehicle operated and owned or leased by a federal, state, or local agency, department, or district, that employs peace officers, as defined by Chapter 4.5 (commencing with Section 830) of Title 3 of Part 2 of the Penal Code, for use by those peace officers in the performance of their duties, is exempt from California law, and regulations adopted pursuant thereto, prohibiting or limiting material that may be placed, displayed, installed, affixed, or applied to the side or rear windows, commonly referred to as window tinting or glazing.

Added Stats 2012 ch 171 § 1 (AB 2660), effective January 1, 2013.

#### § 26709. Mirrors

(a) Every motor vehicle registered in a foreign jurisdiction and every motorcycle subject to registration in this state shall be equipped with a mirror so located as to reflect to the driver a view of the highway for a distance of at least 200 feet to the rear of such vehicle.

Every motor vehicle subject to registration in this state, except a motorcycle, shall be equipped with not less than two such mirrors, including one affixed to the left-hand side.

(b) The following described types of motor vehicles, of a type subject to registration, shall be equipped with mirrors on both the left- and right-hand sides of the vehicle so located as to reflect to the driver a view of the highway through each mirror for a distance of at least 200 feet to the rear of such vehicle:

(1) A motor vehicle so constructed or loaded as to obstruct the driver's view to the rear.

(2) A motor vehicle towing a vehicle and the towed vehicle or load thereon obstructs the driver's view to the rear.

(3) A bus or trolley coach.

(c) The provisions of subdivision (b) shall not apply to a passenger vehicle when the load obstructing the driver's view consists of passengers.

Enacted Stats 1959 ch 3. Amended Stats 1959 ch 1019 § 1; Stats 1961 ch 1381 § 1; Stats 1963 ch 480 § 1; Stats 1965 ch 1312 § 1; Stats 1967 ch 548 § 1, operative January 1, 1968; Stats 1970 ch 74 § 1.

**§ 26710. Defective windshields and rear windows**

It is unlawful to operate any motor vehicle upon a highway when the windshield or rear window is in such a defective condition as to impair the driver's vision either to the front or rear.

In the event any windshield or rear window fails to comply with this code the officer making the inspection shall direct the driver to make the windshield and rear window conform to the requirements of this code within 48 hours. The officer may also arrest the driver and give him notice to appear and further require the driver or the owner of the vehicle to produce in court satisfactory evidence that the windshield or rear window has been made to conform to the requirements of this code.

Enacted Stats 1959 ch 3.

**§ 26711. Eyeshades for bus or trolley operators**

Every bus or trolley coach, except those first registered prior to January 1, 1960, and engaged in urban and suburban service as defined in Section 35107, shall be equipped with movable eyeshades of sufficient size to shade the eyes of the operator of a bus or trolley coach while it is being driven facing the sun.

Added Stats 1961 ch 1381 § 2. Amended Stats 1963 ch 661 § 1.

**§ 26712. Defroster required**

Every passenger vehicle used or maintained for the transportation of persons for hire, compensation, or profit shall be equipped with a defrosting device which is adequate to remove snow, ice, frost, fog, or internal moisture from the windshield.

Added Stats 1965 ch 1601 § 1.

**CHAPTER 5**

**Other Equipment**

**ARTICLE 1**

**Horns, Sirens, and Amplification Devices**

Section

27000. Horns; Backup device or alarm and video camera on garbage trucks

27002. Sirens

27003. Sirens on armored cars

**§ 27000. Horns; Backup device or alarm and video camera on garbage trucks**

(a) A motor vehicle, when operated upon a highway, shall be equipped with a horn in good working order and capable of emitting sound audible under normal conditions from a distance of not less than 200 feet, but no horn shall emit an unreasonably loud or harsh sound. An authorized emergency vehicle may be equipped with,

and use in conjunction with the siren on that vehicle, an air horn that emits sounds that do not comply with the requirements of this section.

(b) A refuse or garbage truck shall be equipped with an automatic backup audible alarm that sounds on backing and is capable of emitting sound audible under normal conditions from a distance of not less than 100 feet or shall be equipped with an automatic backup device that is in good working order, located at the rear of the vehicle and that immediately applies the service brake of the vehicle on contact by the vehicle with any obstruction to the rear. The backup device or alarm shall also be capable of operating automatically when the vehicle is in neutral or a forward gear but rolls backward.

(c) A refuse or garbage truck, except a vehicle, known as a rolloff vehicle, that is used for the express purpose of transporting waste containers such as open boxes or compactors, purchased after January 1, 2010, shall also be equipped with a functioning camera providing a video display for the driver that enhances or supplements the driver's view behind the truck for the purpose of safely maneuvering the truck.

(d)(1) A construction vehicle with a gross vehicle weight rating (GVWR) in excess of 14,000 pounds that operates at, or transports construction or industrial materials to and from, a mine or construction site, or both, shall be equipped with an automatic backup audible alarm that sounds on backing and is capable of emitting sound audible under normal conditions from a distance of not less than 200 feet.

(2) As used in this subdivision, "construction vehicle" includes, but is not limited to, all of the following:

(A) A vehicle designed to transport concrete, cement, clay, limestone, aggregate material as defined in subdivision (d) of Section 23114, or other similar construction or industrial material, including a transfer truck or a tractor trailer combination used exclusively to pull bottom dump, end dump, or side dump trailers.

(B) A vehicle that is a concrete mixer truck, a truck with a concrete placing boom, a water tank truck, a single engine crane with a load rating of 35 tons or more, or a tractor that exclusively pulls a low-boy trailer.

Enacted Stats 1959 ch 3. Amended Stats 1965 ch 1015 § 1; Stats 1982 ch 926 § 1, effective September 13, 1982; Stats 1983 ch 1144 § 8, effective September 28, 1983; Stats 1997 ch 945 § 27 (AB 1561); Stats 2005 ch 166 § 2 (AB 1637), effective January 1, 2006; Stats 2011 ch 235 § 1 (SB 341), effective January 1, 2012.

**§ 27002. Sirens**

No vehicle, except an authorized emergency vehicle, shall be equipped with, nor shall any person use upon a vehicle any siren except that an authorized emergency vehicle shall be equipped with a siren meeting requirements established by the department.

Enacted Stats 1959 ch 3. Amended Stats 1961 ch 653 § 50, operative January 1, 1962; Stats 1979 ch 723 § 29.

**§ 27003. Sirens on armored cars**

An armored car may be equipped with a siren which may be used while resisting armed robbery. At all other times, the siren shall not be sounded. The authority to use a siren granted by this section does not constitute an armored car an authorized emergency vehicle, and all



other provisions of this code applicable to drivers of vehicles apply to drivers of armored cars.

Enacted Stats 1959 ch 3.

## ARTICLE 2

### Exhaust Systems

#### Section

- 27150. Adequate muffler requirement; Off-highway vehicles
- 27150.1. Sale of exhaust systems; Compliance with regulations and standards
- 27150.2. Certificates of compliance; Fee; Exemptions
- 27150.5. Sale of non-complying exhaust system
- 27150.7. Dismissal of prosecution
- 27151. Modification of exhaust systems
- 27153. Exhaust products
- 27156. Air pollution control devices; Gross polluters
- 27156.1. Auxiliary gasoline fuel tanks
- 27156.2. Exemption for emergency vehicles
- 27156.3. Vehicles exempt from pollution control device requirements
- 27157. Vehicle pollution emission regulations
- 27158. Certificates of compliance; Vehicle inspection
- 27158.5. Certificate of compliance or inspection; 1955 through 1965 model year motor vehicles
- 27159. Storage of vehicle on request of State Air Resources Board

#### § 27150. Adequate muffler requirement; Off-highway vehicles

(a) Every motor vehicle subject to registration shall at all times be equipped with an adequate muffler in constant operation and properly maintained to prevent any excessive or unusual noise, and no muffler or exhaust system shall be equipped with a cutout, bypass, or similar device.

(b) Except as provided in Division 16.5 (commencing with Section 38000) with respect to off-highway motor vehicles subject to identification, every passenger vehicle operated off the highways shall at all times be equipped with an adequate muffler in constant operation and properly maintained so as to meet the requirements of Article 2.5 (commencing with Section 27200), and no muffler or exhaust system shall be equipped with a cutout, bypass, or similar device.

(c) The provisions of subdivision (b) shall not be applicable to passenger vehicles being operated off the highways in an organized racing or competitive event conducted under the auspices of a recognized sanctioning body or by permit issued by the local governmental authority having jurisdiction.

Enacted Stats 1959 ch 3. Amended Stats 1971 ch 714 § 1, ch 735 § 1, ch 952 § 2, ch 1816 § 8; Stats 1972 ch 973 § 19, effective August 16, 1972; Stats 1977 ch 558 § 1, ch 579 § 188 (ch 558 prevails).

#### § 27150.1. Sale of exhaust systems; Compliance with regulations and standards

No person engaged in a business that involves the selling of motor vehicle exhaust systems, or parts thereof, including, but not limited to, mufflers, shall offer for sale, sell, or install, a motor vehicle exhaust system, or part thereof, including, but not limited to, a muffler, unless it meets the regulations and standards applicable pursuant to this article. Motor vehicle exhaust systems or parts thereof include, but are not limited to, nonoriginal exhaust equipment.

A violation of this section is a misdemeanor.

Added Stats 1971 ch 1769 § 1. Amended Stats 1973 ch 610 § 1; Stats 2001 ch 92 § 3 (SB 1081); Stats 2002 ch 569 § 2 (SB 1420).

#### § 27150.2. Certificates of compliance; Fee; Exemptions

(a) Stations providing referee functions pursuant to Section 44036 of the Health and Safety Code shall provide for the testing of vehicular exhaust systems and the issuance of certificates of compliance only for those vehicles that have received a citation for a violation of Section 27150 or 27151.

(b) A certificate of compliance for a vehicular exhaust system shall be issued pursuant to subdivision (a) if the vehicle complies with Sections 27150 and 27151. Exhaust systems installed on motor vehicles, other than motorcycles, with a manufacturer's gross vehicle weight rating of less than 6,000 pounds comply with Sections 27150 and 27151 if they emit no more than 95 dbA when tested in accordance with Society of Automotive Engineers Standard J1169 May 1998.

(c) An exhaust system certificate of compliance issued pursuant to subdivision (a) shall identify, to the extent possible, the make, model, year, license number, and vehicle identification number of the vehicle tested, and the make and model of the exhaust system installed on the vehicle.

(d) The station shall charge a fee for the exhaust system certificate of compliance issued pursuant to subdivision (a). The fee charged shall be calculated to recover the costs incurred by the Department of Consumer Affairs to implement this section. The fees charged by the station shall be deposited in the Vehicle Inspection and Repair Fund established by Section 44062 of the Health and Safety Code.

(e) Vehicular exhaust systems are exempt from the requirements of Sections 27150 and 27151 if compliance with those sections, or the regulations adopted pursuant thereto, would cause an unreasonable hardship without resulting in a sufficient corresponding benefit with respect to noise level control.

Added Stats 1971 ch 1769 § 2. Amended Stats 2001 ch 92 § 4 (SB 1081). Amended Stats 2002 ch 569 § 3 (SB 1420).

#### § 27150.5. Sale of non-complying exhaust system

Any person holding a retail seller's permit who sells or installs an exhaust system, or part thereof, including, but not limited to, a muffler, in violation of Section 27150.1 or 27150.2 or the regulations adopted pursuant thereto, shall thereafter be required to install an exhaust system, or part thereof, including, but not limited to, a muffler, which is in compliance with such regulations upon demand of the purchaser or registered owner of the vehicle concerned, or to reimburse the purchaser or registered owner for the expense of replacement and installation of an exhaust system, or part thereof, including, but not limited to, a muffler, which is in compliance, at the election of such purchaser or registered owner.

Added Stats 1971 ch 1769 § 5.

#### § 27150.7. Dismissal of prosecution

A court may dismiss any action in which a person is prosecuted for operating a vehicle in violation of Section 27150 or 27151 if a certificate of compliance has been issued by a station pursuant to Section 27150.2, or if the defendant had reasonable grounds to believe that the exhaust system was in good working order and had

reasonable grounds to believe that the vehicle was not operated in violation of Section 27150 or 27151.

Added Stats 1971 ch 1769 § 7. Amended Stats 2001 ch 92 § 8 (SB 1081). Amended Stats 2002 ch 569 § 4 (SB 1420).

#### § 27151. Modification of exhaust systems

(a) No person shall modify the exhaust system of a motor vehicle in a manner which will amplify or increase the noise emitted by the motor of the vehicle so that the vehicle is not in compliance with the provisions of Section 27150 or exceeds the noise limits established for the type of vehicle in Article 2.5 (commencing with Section 27200). No person shall operate a motor vehicle with an exhaust system so modified.

(b) For the purposes of exhaust systems installed on motor vehicles with a manufacturer's gross vehicle weight rating of less than 6,000 pounds, other than motorcycles, a sound level of 95 dbA or less, when tested in accordance with Society of Automotive Engineers Standard J1169 May 1998, complies with this section. Motor vehicle exhaust systems or parts thereof include, but are not limited to, nonoriginal exhaust equipment.

Enacted Stats 1959 ch 3. Amended Stats 1971 ch 503 § 1; Stats 1980 ch 382 § 1. Amended Stats 2001 ch 92 § 10 (SB 1081).

#### § 27153. Exhaust products

No motor vehicle shall be operated in a manner resulting in the escape of excessive smoke, flame, gas, oil, or fuel residue.

The provisions of this section apply to motor vehicles of the United States or its agencies, to the extent authorized by federal law.

Enacted Stats 1959 ch 3. Amended Stats 1971 ch 739 § 5.

#### § 27156. Air pollution control devices; Gross polluters

(a) No person shall operate or leave standing upon a highway a motor vehicle that is a gross polluter, as defined in Section 39032.5 of the Health and Safety Code.

(b) No person shall operate or leave standing upon a highway a motor vehicle that is required to be equipped with a motor vehicle pollution control device under Part 5 (commencing with Section 43000) of Division 26 of the Health and Safety Code or any other certified motor vehicle pollution control device required by any other state law or any rule or regulation adopted pursuant to that law, or required to be equipped with a motor vehicle pollution control device pursuant to the National Emission Standards Act (42 U.S.C. Secs. 7521 to 7550, inclusive) and the standards and regulations adopted pursuant to that federal act, unless the motor vehicle is equipped with the required motor vehicle pollution control device that is correctly installed and in operating condition. No person shall disconnect, modify, or alter any such required device.

(c) No person shall install, sell, offer for sale, or advertise any device, apparatus, or mechanism intended for use with, or as a part of, a required motor vehicle pollution control device or system that alters or modifies the original design or performance of the motor vehicle pollution control device or system.

(d) If the court finds that a person has willfully violated this section, the court shall impose the maxi-

mum fine that may be imposed in the case, and no part of the fine may be suspended.

(e) "Willfully," as used in this section, has the same meaning as the meaning of that word prescribed in Section 7 of the Penal Code.

(f) No person shall operate a vehicle after notice by a traffic officer that the vehicle is not equipped with the required certified motor vehicle pollution control device correctly installed in operating condition, except as may be necessary to return the vehicle to the residence or place of business of the owner or driver or to a garage, until the vehicle has been properly equipped with such a device.

(g) The notice to appear issued or complaint filed for a violation of this section shall require that the person to whom the notice to appear is issued, or against whom the complaint is filed, produce proof of correction pursuant to Section 40150 or proof of exemption pursuant to Section 4000.1 or 4000.2.

(h) This section shall not apply to an alteration, modification, or modifying device, apparatus, or mechanism found by resolution of the State Air Resources Board to do either of the following:

(1) Not to reduce the effectiveness of a required motor vehicle pollution control device.

(2) To result in emissions from the modified or altered vehicle that are at levels that comply with existing state or federal standards for that model-year of the vehicle being modified or converted.

(i) Aftermarket and performance parts with valid State Air Resources Board Executive Orders may be sold and installed concurrent with a motorcycle's transfer to an ultimate purchaser.

(j) This section applies to motor vehicles of the United States or its agencies, to the extent authorized by federal law.

Added Stats 1st Ex Sess 1960 ch 23 § 3.5. Amended Stats 1963 ch 2028 § 3; Stats 1965 ch 2031 § 13, effective July 23, 1965; Stats 1968 ch 49 § 10, ch 1207 § 1; Stats 1969 ch 9 § 6, effective March 6, 1969, ch 622 § 3, effective July 28, 1969, ch 1253 § 4, effective August 31, 1969; Stats 1970 ch 331 § 1; Stats 1971 ch 739 § 7; Stats 1972 ch 503 § 3; Stats 1975 ch 957 § 31; Stats 1976 ch 231 § 7; Stats 1994 ch 27 § 62 (AB 2018), effective March 30, 1994; Stats 2007 ch 325 § 1 (AB 829), effective January 1, 2008.

#### § 27156.1. Auxiliary gasoline fuel tanks

The installation, prior to January 1, 1974, of an auxiliary gasoline fuel tank for use on a 1973 or earlier model year motor vehicle, which vehicle is required, pursuant to Part 5 (commencing with Section 43000) of Division 26 of the Health and Safety Code or the National Emission Standards Act (42 U.S.C., Secs. 1857f-1 to 1857f-7, inclusive), to be equipped with a fuel system evaporative loss control device, shall not be deemed a violation of Section 27156 of this code. As used in this section, the term "auxiliary gasoline fuel tank," has the same meaning as defined in subdivision (b) of Section 43834 of the Health and Safety Code.

Added Stats 1973 ch 836 § 3, effective September 25, 1973. Amended Stats 1975 ch 957 § 32.

#### § 27156.2. Exemption for emergency vehicles

Notwithstanding any other provision of law, any publicly owned authorized emergency vehicle operated by a peace officer, as defined in Section 830 of the Penal Code,

any authorized emergency vehicle, as defined in Section 165 and used for fighting fires or responding to emergency fire calls pursuant to paragraph (2) of subdivision (b) or pursuant to subdivision (c) or (d) of that section, and any publicly owned authorized emergency vehicle used by an emergency medical technician-paramedic, as defined in Section 1797.84 of the Health and Safety Code, is exempt from requirements imposed pursuant to California law and the regulations adopted pursuant thereto for motor vehicle pollution control devices.

Added Stats 1981 ch 595 § 1.

**§ 27156.3. Vehicles exempt from pollution control device requirements**

Notwithstanding any other provision of law, any motor vehicle of mosquito abatement, vector control, or pest abatement districts or agencies, any authorized emergency vehicle as defined in Section 165, except subdivision (f) thereof, and any ambulance used by a private entity under contract with a public agency, is exempt from requirements imposed pursuant to California law and the regulations adopted pursuant thereto for motor vehicle pollution control devices.

Added Stats 1981 ch 669 § 1, effective September 23, 1981, as Veh C § 27156.2. Renumbered by Stats 1982 ch 466 § 116.

**§ 27157. Vehicle pollution emission regulations**

The State Air Resources Board, after consultation with, and pursuant to the recommendations of, the commissioner, shall adopt such reasonable regulations as it determines are necessary for the public health and safety regarding the maximum allowable emissions of pollutants from vehicles upon a highway. Such regulations shall apply only to vehicles required by Part 5 (commencing with Section 43000) of Division 26 of the Health and Safety Code or any federal law or regulation to be equipped with devices or systems to control emission of pollutants from the exhaust and shall not be stricter than the emission standards required of that model year motor vehicle when first manufactured.

Added Stats 1970 ch 1295 § 13. Amended Stats 1979 ch 373 § 327.

**§ 27158. Certificates of compliance; Vehicle inspection**

After notice by a traffic officer that a vehicle does not comply with any regulation adopted pursuant to Section 27157, no person shall operate, and no owner shall permit the operation of, such vehicle for more than 30 days thereafter unless a certificate of compliance has been issued for such vehicle in accordance with the provisions of Section 9889.18 of the Business and Professions Code or unless the department has checked the vehicle and determined that the vehicle has been made to comply with such regulation adopted pursuant to Section 27157. A certificate of compliance issued for such vehicle shall, for a period of one year from date of issue, constitute proof of compliance with any regulations adopted pursuant to Section 27157 provided that no required pollution control device has been disconnected, modified, or altered or has been adjusted by other than a licensed installer in a licensed motor vehicle pollution control device installation and inspection station subsequent to the issuance of the certificate of compliance. The

provisions of this section shall apply to the United States and its agencies to the extent authorized by federal law.

Added Stats 1970 ch 1295 § 14. Amended Stats 1971 ch 739 § 8, ch 1578 § 8; Stats 1974 ch 769 § 1.

**§ 27158.5. Certificate of compliance or inspection; 1955 through 1965 model year motor vehicles**

After notice by a traffic officer that a motor vehicle does not comply with any standard adopted pursuant to Section 27157.5, no person shall operate, and no owner shall permit the operation of, such motor vehicle for more than 30 days thereafter unless a certificate of compliance has been issued for such vehicle in accordance with the provisions of Section 9889.18 of the Business and Professions Code or unless the department has checked the vehicle and determined that the vehicle has been made to comply with such standard adopted pursuant to Section 27157.5. A certificate of compliance issued for such vehicle shall, for a period of one year from date of issue, constitute proof of compliance with the standards determined pursuant to Section 27157.5.

Added Stats 1971 ch 1095 § 3. Amended Stats 1971 ch 1578 § 9; Stats 1974 ch 769 § 2.

**§ 27159. Storage of vehicle on request of State Air Resources Board**

Any uniformed member of the California Highway Patrol may order a vehicle stored when it is located within the territorial limits in which the member may act if requested by a representative of the State Air Resources Board to remove the vehicle from service pursuant to subdivision (f) of Section 44011.6 of the Health and Safety Code. All towing and storage fees for a vehicle removed under this section shall be paid by the owner.

Added Stats 1990 ch 1433 § 24 (SB 1874).

**ARTICLE 2.5  
Noise Limits**

**Section**

- 27201. Pre-1970 motorcycle limit
- 27202. Motorcycle limits
  - 27202.1. Environmental protection agency exhaust system label required; Violations; Penalties
- 27204. Applicable limits within specified manufacturer's gross vehicle weight rating and date of manufacture
- 27206. Limits for other vehicles

**§ 27201. Pre-1970 motorcycle limit**

For the purposes of Section 27200, the noise limit of 92 dbA shall apply to any motorcycle manufactured before 1970.

Added Stats 1975 ch 83 § 3.

**§ 27202. Motorcycle limits**

For the purposes of Section 27200, the following noise limits shall apply to any motorcycle, other than a motor-driven cycle, manufactured:

- (1) After 1969, and before 1973 ..... 88 dbA
- (2) After 1972, and before 1975 ..... 86 dbA
- (3) After 1974, and before 1986 ..... 83 dbA

(4) After 1985 ..... 80 dbA  
 Added Stats 1975 ch 83 § 3. Amended Stats 1976 ch 464 § 1; Stats 1980 ch 358 § 1; Stats 1981 ch 81 § 1; Stats 1982 ch 356 § 1.

**§ 27202.1. Environmental protection agency exhaust system label required; Violations; Penalties**

(a) Notwithstanding any other law, a person shall not park, use, or operate a motorcycle, registered in the State of California, that does not bear the required applicable federal Environmental Protection Agency exhaust system label pursuant to Subparts D (commencing with Section 205.150) and E (commencing with Section 205.164) of Part 205 of Title 40 of the Code of Federal Regulations. A violation of this section shall be considered a mechanical violation and a peace officer shall not stop a motorcycle solely on a suspicion of a violation of this section. A peace officer shall cite a violation of this section as a secondary infraction.

(b) A violation of this section is punishable as follows:

(1) For a first conviction, by a fine of not less than fifty dollars (\$50), nor more than one hundred dollars (\$100).

(2) For a second or subsequent conviction, by a fine of not less than one hundred dollars (\$100), nor more than two hundred fifty dollars (\$250).

(c)(1) The notice to appear issued or complaint filed for a violation of this section shall require that the person to whom the notice to appear is issued, or against whom the complaint is filed, produce proof of correction pursuant to Section 40150.

(2) Upon producing proof of correction to the satisfaction of the court, the court may dismiss the penalty imposed pursuant to subdivision (b) for a first violation of this section.

(d)(1) This section is applicable to a person operating a motorcycle that is manufactured on or after January 1, 2013, or a motorcycle with aftermarket exhaust system equipment that is manufactured on or after January 1, 2013.

(2) Penalties imposed pursuant to this section are in addition to penalties imposed pursuant to any other applicable laws or regulations.

(3) This section does not supersede, negate, or otherwise alter any other applicable laws or regulations.

Added Stats 2010 ch 407 § 1 (SB 435), effective January 1, 2011.

**§ 27204. Applicable limits within specified manufacturer's gross vehicle weight rating and date of manufacture**

For the purposes of Section 27200, the following noise limits shall apply to any motor vehicle within the specified manufacturer's gross vehicle weight rating and date of manufacture:

GVWR—Pounds	Date of Manufacture	Noise Limit—dbA
Over 6,000	after 1967 and before 1973	88
Over 6,000	after 1972 and before 1975	86
Over 6,000	after 1974 and before 1978	83

Over 8,500	after 1977 and before 1982	83
Over 6,000 but not over 8,500	after 1977	80
Over 8,500 but not over 10,000	after 1981	80
Over 10,000	after 1981 and before 1988	83
Over 10,000	after 1987	80

Added Stats 1982 ch 793 § 2. Amended Stats 1985 ch 274 § 1.

**§ 27206. Limits for other vehicles**

For the purposes of Section 27200, the following noise limits shall apply to any other motor vehicle, not specified in this article, manufactured:

- (1) After 1967, and before 1973... 86 dbA
- (2) After 1972, and before 1975... 84 dbA
- (3) After 1975 ..... 80 dbA

Added Stats 1975 ch 83 § 3, as Veh C § 27205. Amended and renumbered Stats 1977 ch 558 § 4.

**ARTICLE 3**

**Safety Belts and Inflatable Restraint Systems**

Section  
 27302. Sale of seatbelts  
 27317. Vehicle's computer system or supplemental restraint system; Previously deployed air bag or components; Violations; Punishment

**§ 27302. Sale of seatbelts**

No person shall sell or offer for sale any seatbelt or attachments thereto for use in a vehicle unless it complies with requirements established by the department.

Enacted Stats 1959 ch 3. Amended Stats 1968 ch 980 § 32; Stats 1979 ch 723 § 30.

**§ 27317. Vehicle's computer system or supplemental restraint system; Previously deployed air bag or components; Violations; Punishment**

A person who installs, reinstalls, rewires, tampers with, alters, or modifies for compensation, a vehicle's computer system or supplemental restraint system, including, but not limited to, the supplemental restraint system's on-board system performance indicators, so that it falsely indicates the supplemental restraint system is in proper working order, or who knowingly distributes or sells a previously deployed air bag or previously deployed air bag component that will no longer meet the original equipment manufacturing form or function for proper operation, is guilty of a misdemeanor punishable by a fine of up to five thousand dollars (\$5,000) or by imprisonment in a county jail for up to one year, or by both the fine and imprisonment.

Added Stats 1999 ch 449 § 2 (AB 1471). Amended Stats 2012 ch 97 § 1 (AB 1854), effective January 1, 2013.

**ARTICLE 4**

**Tires**

Section  
 27450. Thickness of solid tire

## Section

- 27451. Measurement of solid tire
- 27452. Condition of solid tire
- 27455. Inner tubes
- 27460.5. Sale of recut or regrooved tires
- 27461. Use of recut or regrooved tires
- 27465. Tread depth of pneumatic tires
- 27500. Pneumatic tire standard regulations
- 27501. Pneumatic tires not conforming to regulations
- 27502. Sale of tires not conforming to noise standards
- 27503. Adoption of regulations; Noise standards for tires

**§ 27450. Thickness of solid tire**

When any vehicle is equipped with any solid tire, the solid tire shall have a minimum thickness of resilient rubber as follows:

- (a) If the width of the tire is three inches but less than six inches, one inch thick.
- (b) If the width of the tire is six inches but not more than nine inches, 1¼ inches thick.
- (c) If the width of the tire is more than nine inches, 1½ inches thick.

Enacted Stats 1959 ch 3.

**§ 27451. Measurement of solid tire**

The rubber of a solid tire shall be measured between the surface of the roadway and the nearest metal part of the base flange to which the tire is attached at the point where the concentrated weight of the vehicle bears upon the surface of the roadway.

Enacted Stats 1959 ch 3.

**§ 27452. Condition of solid tire**

The required thickness of rubber shall extend evenly around the entire periphery of the tire. The entire solid tire shall be securely attached to the channel base and shall be without flat spots or bumpy rubber.

Enacted Stats 1959 ch 3.

**§ 27455. Inner tubes**

(a) On and after January 1, 1975, no person shall sell or offer for sale an inner tube for use in a radial tire unless, at the time of manufacture, the tube valve stem is colored red or is distinctly marked in accordance with rules and regulations adopted by the department, taking into consideration the recommendations of manufacturers of inner tubes.

(b) No person shall install an inner tube in a radial tire unless the inner tube is designed for use in a radial tire.

Added Stats 1973 ch 741 § 1, effective September 25, 1973.

**§ 27460.5. Sale of recut or regrooved tires**

No person shall knowingly sell or offer or expose for sale any motor vehicle tire except a commercial vehicle tire, or any motor vehicle equipped with any tire except a commercial vehicle tire, which has been recut or regrooved. For purposes of this section a recut or regrooved tire is an unretreaded or unrecapped tire into which new grooves have been cut or burned.

Added Stats 1965 ch 1518 § 1.

**§ 27461. Use of recut or regrooved tires**

No person shall cause or permit the operation of and no driver shall knowingly operate any motor vehicle

except a commercial vehicle, on any street or highway, which is equipped with one or more recut or regrooved tires. For purposes of this section a recut or regrooved tire is an unretreaded or unrecapped tire into which new grooves have been cut or burned.

Added Stats 1965 ch 1518 § 2.

**§ 27465. Tread depth of pneumatic tires**

(a) No dealer or person holding a retail seller's permit shall sell, offer for sale, expose for sale, or install on a vehicle axle for use on a highway, a pneumatic tire when the tire has less than the tread depth specified in subdivision (b). This subdivision does not apply to any person who installs on a vehicle, as part of an emergency service rendered to a disabled vehicle upon a highway, a spare tire with which the disabled vehicle was equipped.

(b) No person shall use on a highway a pneumatic tire on a vehicle axle when the tire has less than the following tread depth, except when temporarily installed on a disabled vehicle as specified in subdivision (a):

(1) One thirty-second ( $\frac{1}{32}$ ) of an inch tread depth in any two adjacent grooves at any location of the tire, except as provided in paragraphs (2) and (3).

(2) Four thirty-second ( $\frac{4}{32}$ ) of an inch tread depth at all points in all major grooves on a tire on the steering axle of any motor vehicle specified in Section 34500, and two thirty-second ( $\frac{2}{32}$ ) of an inch tread depth at all points in all major grooves on all other tires on the axles of these vehicles.

(3) Six thirty-second ( $\frac{6}{32}$ ) of an inch tread depth at all points in all major grooves on snow tires used in lieu of tire traction devices in posted tire traction device control areas.

(c) The measurement of tread depth shall not be made where tie bars, humps, or fillets are located.

(d) The requirements of this section shall not apply to implements of husbandry.

(e) The department, if it determines that such action is appropriate and in keeping with reasonable safety requirements, may adopt regulations establishing more stringent tread depth requirements than those specified in this section for those vehicles defined in Sections 322 and 545, and may adopt regulations establishing tread depth requirements different from those specified in this section for those vehicles listed in Section 34500.

Added Stats 1970 ch 216 § 2. Amended Stats 1971 ch 510 § 4; Stats 1976 ch 70 § 2, effective March 27, 1976; Stats 1977 ch 77 § 1, effective May 26, 1977, ch 733 § 1; Stats 1980 ch 676 § 313; Stats 1984 ch 1567 § 1; Stats 1990 ch 71 § 8 (AB 2498), effective April 30, 1990.

**§ 27500. Pneumatic tire standard regulations**

(a) The department may adopt regulations relating to standards for pneumatic tires of a vehicle type as it determines necessary to provide for public safety.

(b) In adopting these regulations, the department shall consider as evidence of generally accepted standards, the rules and regulations which have been adopted by the Federal Highway Administration and Rubber Manufacturers Association.

Added Stats 1965 ch 1619 § 1. Amended Stats 1970 ch 216 § 3.

**§ 27501. Pneumatic tires not conforming to regulations**

(a) No dealer or person holding a retail seller's permit shall sell, offer for sale, expose for sale, or install on a

vehicle for use on a highway, a pneumatic tire which is not in compliance with regulations adopted pursuant to Section 27500. This subdivision shall not apply to any person who installs on a vehicle, as part of an emergency service rendered to a vehicle upon a highway, a spare tire with which such disabled vehicle was equipped.

(b) No person shall use on a highway a pneumatic tire which is not in conformance with such regulations.

Added Stats 1970 ch 216 § 4. Amended Stats 1971 ch 510 § 5; Stats 1976 ch 70 § 3, effective March 27, 1976.

**§ 27502. Sale of tires not conforming to noise standards**

No dealer or person holding a retail seller's permit shall sell, offer for sale, expose for sale, or install on a vehicle for use on a highway, a tire which is not in compliance with regulations adopted pursuant to Section 27503.

Added Stats 1971 ch 1197 § 1.

**§ 27503. Adoption of regulations; Noise standards for tires**

(a) The commissioner, after public hearings, shall adopt regulations setting noise standards for pneumatic

tires. Such standards shall be the lowest level of noise consistent with economic and technological feasibility and with public safety as stated in the regulations adopted pursuant to Section 27500. Such standards may be adopted for each tire-vehicle type combination. The regulations may require the manufacturer to prove to the commissioner that the tire meets the standards, subject to such inspection as the commissioner prescribes. The regulations shall be filed with the Legislature eight months after the federal study on tire noise is available, and shall become operative one year after such filing.

(b) It is the intent of the Legislature in enacting this section that the commissioner shall consider recommendations of the United States Department of Transportation before developing independent standards for tire noise.

Added Stats 1971 ch 1197 § 2.

**DIVISION 17**

**Offenses and Prosecution**

**CHAPTER 1**

**Offenses**

**ARTICLE 1**

**Violation of Code**

Section 40000.7. Additional misdemeanors

**§ 40000.7. Additional misdemeanors**

(a) A violation of any of the following provisions is a misdemeanor, and not an infraction:

(1) Section 2416, relating to regulations for emergency vehicles.

(2) Section 2800, relating to failure to obey an officer's lawful order or submit to a lawful inspection.

(3) Section 2800.1, relating to fleeing from a peace officer.

(4) Section 2801, relating to failure to obey a firefighter's lawful order.

(5) Section 2803, relating to unlawful vehicle or load.

(6) Section 2813, relating to stopping for inspection.

(7) Subdivisions (b), (c), and (d) of Section 4461 and subdivisions (b) and (c) of Section 4463, relating to disabled person placards and disabled person and disabled veteran license plates.

(8) Section 4462.5, relating to deceptive or false evidence of vehicle registration.

(9) Section 4463.5, relating to deceptive or facsimile license plates.

(10) Section 5500, relating to the surrender of registration documents and license plates before dismantling may begin.

(11) Section 5506, relating to the sale of a total loss salvage vehicle, or of a vehicle reported for dismantling by a salvage vehicle rebuilder.

(12) Section 5753, relating to delivery of certificates of ownership and registration when committed by a dealer or any person while a dealer within the preceding 12 months.

(13) Section 5901, relating to dealers and lessor-retailers giving notice.

(14) Section 5901.1, relating to lessors giving notice and failure to pay fee.

(15) Section 8802, relating to the return of canceled, suspended, or revoked certificates of ownership, registration cards, or license plates, when committed by any person with intent to defraud.

(16) Section 8803, relating to return of canceled, suspended, or revoked documents and license plates of a dealer, manufacturer, remanufacturer, transporter, dismantler, or salesman.

(b) This section shall become operative on January 1, 2001.

Added Stats 1996 ch 697 § 4 (AB 2852), operative January 1, 2001. Amended Stats 2002 ch 670 § 10 (SB 1331); Stats 2010 ch 709 § 26 (SB 1062), effective January 1, 2011.

## DIVISION 18

## Penalties and Disposition of Fees, Fines, and Forfeitures

## CHAPTER 1

## Penalties

## ARTICLE 1

## Public Offenses

## Section

42001.1. Punishment for specified infractions and misdemeanors; Bicycle fine schedule

42001.2. Violation of motor vehicle exhaust standards; Allocation of revenues collected from fines and forfeitures

42001.14. Punishment for disconnecting, modifying, or altering pollution control device; Allocation and use of fines

**§ 42001.1. Punishment for specified infractions and misdemeanors; Bicycle fine schedule**

(a) Except as provided in this code, a person convicted of an infraction for a violation of this code or of a local ordinance adopted pursuant to this code shall be punished as follows:

(1) By a fine not exceeding one hundred dollars (\$100).

(2) For a second infraction occurring within one year of a prior infraction that resulted in a conviction, a fine not exceeding two hundred dollars (\$200).

(3) For a third or subsequent infraction occurring within one year of two or more prior infractions that resulted in convictions, a fine not exceeding two hundred fifty dollars (\$250).

(b) A pedestrian convicted of an infraction for a violation of this code or any local ordinance adopted pursuant to this code shall be punished by a fine not exceeding fifty dollars (\$50).

(c) A person convicted of a violation of subdivision (a) or (b) of Section 27150.3 shall be punished by a fine of two hundred fifty dollars (\$250), and a person convicted of a violation of subdivision (c) of Section 27150.3 shall be punished by a fine of one thousand dollars (\$1,000).

(d) Notwithstanding any other provision of law, a local public entity that employs peace officers, as designated under Chapter 4.5 (commencing with Section 830) of Title 3 of Part 2 of the Penal Code, the California State University, and the University of California may, by ordinance or resolution, establish a schedule of fines applicable to infractions committed by bicyclists within its jurisdiction. A fine, including all penalty assessments and court costs, established pursuant to this subdivision shall not exceed the maximum fine, including penalty assessment and court costs, otherwise authorized by this code for that violation. If a bicycle fine schedule is adopted, it shall be used by the courts having jurisdiction over the area within which the ordinance or resolution is applicable instead of the fines, including penalty assessments and court costs, otherwise applicable under this code.

Enacted Stats 1959 ch 3. Amended Stats 1961 ch 1974 § 1; Stats 1965 ch 1123 § 1; Stats 1968 ch 1192 § 16, operative January 1, 1969; Stats 1970 ch 1431 § 7; Stats 1973 ch 1162 § 5; Stats 1975 ch 635 § 2; Stats 1977 ch 1104 § 2; Stats 1978 ch 421 § 7, ch 626 § 3; Stats 1979 ch 373 § 330; Stats 1983 ch 1092 § 402 (ch 619 prevails), ch 619 § 1; Stats 1984 ch 69

§ 2, effective April 5, 1984, ch 396 § 1, ch 508 § 2; Stats 1985 ch 1126 § 7, effective September 28, 1985, operative April 1, 1986; Stats 1987 ch 1170 § 2; Stats 1988 ch 504 § 5, effective August 22, 1988, ch 1054 § 4, ch 1544 § 62; Stats 1991 ch 13 § 66 (AB 37), effective February 13, 1991; Stats 1993 ch 307 § 1 (AB 669); Stats 1997 ch 852 § 3 (AB 1191); Stats 1999 ch 841 § 4 (AB 923); Stats 2000 ch 833 § 13 (AB 2522); Stats 2003 ch 432 § 2 (AB 377), ch 555 § 7.5 (AB 327). Amended Stats 2004 ch 338 § 2 (AB 340), ch 391 § 2 (SB 1085); Stats 2005 ch 166 § 3 (AB 1637), effective January 1, 2006; Stats 2006 ch 538 § 667 (SB 1852), effective January 1, 2007, ch 898 § 4 (SB 1021), effective January 1, 2007, ch 899 § 2 (AB 2752), effective January 1, 2007, ch 900 § 3 (AB 1850), effective January 1, 2007.

**§ 42001.2. Violation of motor vehicle exhaust standards; Allocation of revenues collected from fines and forfeitures**

(a) A person convicted of an infraction for a violation of Section 27153.5 with a motor vehicle having a manufacturer's maximum gross vehicle weight rating of 6,001 or more pounds is punishable by a fine for the first offense of not less than two hundred fifty dollars (\$250) and not more than two thousand five hundred dollars (\$2,500), and for a second or subsequent offense within one year of not less than five hundred dollars (\$500) and not more than five thousand dollars (\$5,000).

(b) A person convicted of an infraction for a second or subsequent violation of Section 27153, or a second or subsequent violation of 27153.5, with a motor vehicle having a manufacturer's maximum gross vehicle weight rating of less than 6,001 pounds, is punishable by a fine of not less than one hundred thirty-five dollars (\$135) nor more than two hundred eighty-five dollars (\$285).

(c) Notwithstanding Section 40616, the penalties in subdivision (b) apply when a person is guilty of willfully violating a written promise to correct, or willfully failing to deliver proof of correction, as prescribed in Section 40616, when an offense described in subdivision (b) was the violation for which the notice to correct was issued and the person was previously convicted of the same offense, except that costs of repair shall be limited to those specified in Section 44017 of the Health and Safety Code.

(d) Notwithstanding any other provision of law and subject to Section 1463.15 of the Penal Code, revenues collected from fines and forfeitures imposed under this section shall be allocated as follows: 15 percent to the county in which the prosecution is conducted, 10 percent to the prosecuting agency, 25 percent to the enforcement agency, except the Department of the California Highway Patrol, and 50 percent to the air quality management district or air pollution control district in which the infraction occurred, to be used for programs to regulate or control emissions from vehicular sources of air pollution. If the enforcement agency is the Department of the California Highway Patrol, the revenues shall be allocated 25 percent to the county in which the prosecution is conducted, 25 percent to the prosecuting agency, and 50 percent to the air quality management district or air pollution control district in which the infraction occurred. If no prosecuting agency is involved, the revenues that would otherwise be allocated to the prosecuting agency shall instead be allocated to the air quality

management district or air pollution control district in which the infraction occurred.

(e) For the purposes of subdivisions (a), (b), and (c), a second or subsequent offense does not include an offense involving a different motor vehicle.

Added Stats 1988 ch 1544 § 63. Amended Stats 1990 ch 367 § 1 (AB 911); Stats 1991 ch 928 § 39 (AB 1886), effective October 13, 1991; Stats 1992 ch 1243 § 110 (AB 3090), effective September 29, 1992. Amended Stats 2003 ch 482 § 4 (SB 708).

**§ 42001.14. Punishment for disconnecting, modifying, or altering pollution control device; Allocation and use of fines**

(a) Every person convicted of an infraction for the offense of disconnecting, modifying, or altering a required pollution control device in violation of Section 27156 shall be punished as follows: (1) For a first conviction, by a fine of not less than fifty dollars (\$50), nor more than one hundred dollars (\$100).

(2) For a second or subsequent conviction, by a fine of not less than one hundred dollars (\$100), nor more than two hundred fifty dollars (\$250).

(b)(1) The fines collected under subdivision (a) shall be allocated pursuant to subdivision (d) of Section 42001.2.

(2) The amounts allocated pursuant to paragraph (1) to the air pollution control district or air quality management district in which the infraction occurred shall first be allocated to the State Air Resources Board and the Bureau of Automotive Repair to pay the costs of the state board and the bureau under Article 8 (commencing with Section 44080) of Chapter 5 of Part 5 of Division 26 of the Health and Safety Code.

(3) The funds collected under subdivision (a) which are not required for purposes of paragraph (2) shall be used for the enforcement of Section 27156 or for the implementation of Article 8 (commencing with Section 44080) of Chapter 5 of Part 5 of Division 26 of the Health and Safety Code.

Added Stats 1992 ch 972 § 3 (SB 1404).



# CALIFORNIA CODE OF REGULATIONS

## TITLE 10 INVESTMENT

### CHAPTER 5. Insurance Commissioner

#### SUBCHAPTER 7.5. Unfair or Deceptive Acts or Practices in the Business of Insurance

##### ARTICLE 1. Fair Claims Settlement Practices Regulations

§ 2695.8. Additional Standards Applicable to Automobile Insurance.  
§ 2695.85. Auto Body Repair Consumer Bill of Rights.

#### § 2695.8. Additional Standards Applicable to Automobile Insurance.

(a) This section enumerates standards which apply to adjustment and settlement of automobile insurance claims.

(1) the words “automobile” and “vehicle” are used synonymously.

(b) In evaluating automobile total loss claims the following standards shall apply:

(1) The insurer may elect a cash settlement that shall be based upon the actual cost of a “comparable automobile” less any deductible provided in the policy. This cash settlement amount shall include all applicable taxes and one-time fees incident to transfer of evidence of ownership of a comparable automobile. This amount shall also include the license fee and other annual fees to be computed based upon the remaining term of the loss vehicle’s current registration. This procedure shall apply whether or not a replacement automobile is purchased.

(A) If the insured chooses to retain the loss vehicle or if the third party claimant retains the loss vehicle, the cash settlement amount shall include the sales tax associated with the cost of a comparable automobile, discounted by the amount of sales tax attributed to the salvage value of the loss vehicle. The cash settlement amount shall also include all fees incident to transfer of the claimant’s vehicle to salvage status. The salvage value may be deducted from the settlement amount and shall be determined by the amount for which a salvage pool or a licensed salvage dealer, wholesale motor vehicle auction or dismantler will purchase the salvage. If requested by the claimant, the insurer shall provide the name, address and telephone number of the salvage dealer, salvage pool, motor vehicle auction or dismantler who will purchase the salvage. The insurer shall disclose in writing to the claimant that notice of the salvage retention by the claimant must be provided to the Department of Motor Vehicles and that this notice may affect the loss vehicle’s future resale and/or insured value. The disclosure must also inform the claimant of his

or her right to seek a refund of the unused license fees from the Department of Motor Vehicles.

(2) A “comparable automobile” is one of like kind and quality, made by the same manufacturer, of the same or newer model year, of the same model type, of a similar body type, with options and mileage similar to the insured vehicle. Newer model year automobiles may not be used as comparable automobiles unless there are not sufficient comparable automobiles of the same model year to make a determination as set forth in Section 2695.8(b) (4), below. In determining the cost of a comparable automobile, the insurer may use either the asking price or actual sale price of that automobile. Any differences between the comparable automobile and the insured vehicle shall be permitted only if the insurer fairly adjusts for such differences. Any adjustments from the cost of a comparable automobile must be discernible, measurable, itemized, and specified as well as appropriate in dollar amount and so documented in the claim file. Deductions taken from the cost of a comparable automobile that cannot be supported shall not be used. The actual cost of a comparable automobile shall not include any deduction for the condition of a loss vehicle unless the documented condition of the loss vehicle is below average for that particular year, make and model of vehicle. This subsection shall not preclude deduction for prior and/or unrelated damage to the loss vehicle. A comparable automobile must have been available for retail purchase by the general public in the local market area within ninety (90) calendar days of the final settlement offer. The comparable automobiles used to calculate the cost shall be identified by the vehicle identification number (VIN), the stock or order number of the vehicle from a licensed dealer, or the license plate number of that comparable vehicle if this information is available. The identification shall also include the telephone number (including area code) or street address of the seller of the comparable automobile.

(3) Notwithstanding subsection (2), above, upon approval by the Department of Insurance, an insurer may use private sales data from the Department of Motor Vehicles, or other approved sources, which does not contain the seller’s telephone number or street address. Approval by the Department of Insurance shall be contingent on the Department’s determination that reasonable steps have been taken to limit the use of private sales data that may be inaccurately reported to the Department of Motor Vehicles, or other approved sources.

(4) The insurer shall take reasonable steps to verify that the determination of the cost of a comparable vehicle is accurate and representative of the market value of a comparable automobile in the local market area. Upon its request, the department shall have access to all records, data, computer programs, or any other information used by the insurer or any other source to determine

market value. The cost of a comparable automobile shall be determined as follows and, once determined, shall be fully itemized and explained in writing for the claimant at the time the settlement offer is made:

(A) when comparable automobiles are available or were available in the local market area in the last 90 days, the average cost of two or more such comparable automobiles; or,

(B) when comparable automobiles are not available or were not available in the local market area in the last 90 days, the average of two or more quotations from two or more licensed dealers in the local market area; or,

(C) the cost of a comparable automobile as determined by a computerized automobile valuation service that produces statistically valid fair market values within the local market area; or

(D) if it is not possible to determine the cost of a comparable automobile by using one of the methods described in subsections (b)(3)(A), (b)(3)(B) and (b)(3)(C) of this section, the cost of a comparable automobile shall otherwise be supported by documentation and fully explained to the claimant. Any adjustments to the cost of a comparable automobile shall be discernible, measurable, itemized, and specified as well as appropriate in dollar amount and so documented in the claims file. Deductions taken from the cost of a comparable automobile that cannot be supported shall not be used

(5) In first party automobile total loss claims, the insurer may elect to offer a replacement automobile which is a specified comparable automobile available to the insured with all applicable taxes, license fees and other fees incident to transfer of evidence of ownership of the automobile paid by the insurer at no cost other than any deductible provided in the policy. The offer and any rejection thereof must be documented in the insurer's claim file. A replacement automobile must be in as good or better overall condition than the insured vehicle and available for inspection within a reasonable distance of the insured's residence.

(6) Subsection 2695.8(b) applies to the evaluation of third party automobile total loss claims, but does not change existing law with respect to the obligations of an insurer in settling such claims with a third party.

(c) In first party automobile total loss claims, every insurer shall provide notice to the insured at the time the settlement payment is sent or final settlement offer is made that if notified by the insured within thirty-five (35) calendar days after the insured receives the claim payment or final settlement offer that he or she cannot purchase a comparable automobile for the gross settlement amount, the insurer will reopen its claim file. If subsequently notified by the insured the insurer shall reopen its claim file and utilize the following procedures:

(1) The insurer shall locate a comparable automobile for the gross settlement amount determined by the company at the time of settlement and shall provide the insured with the information required in (c)(4), below, or offer a replacement vehicle in accordance with section 2695.8(b)(4). Any such vehicle must be available in the local market area; or,

(2) The insurer shall either pay the insured the difference between the amount of the gross settlement and the cost of the comparable automobile which the insured

has located, or negotiate and purchase this vehicle for the insured; or,

(3) The insurer shall invoke the appraisal provision of the insurance policy.

(4) No insurer is required to take action under this subsection if its documentation to the insured at the time of final settlement offer included written notification of the identity of a specified comparable automobile which was available for purchase at the time of final settlement offer for the gross settlement amount determined by the insurer. The documentation shall include the telephone number (including area code) or street address of the seller of the comparable automobile and:

(A) the vehicle identification number (VIN) or,

(B) the stock or order number of the vehicle from a licensed dealer, or

(C) the license plate number of such comparable vehicle.

(d) No insurer shall, where liability and damages are reasonably clear, recommend that the third party claimant make a claim under his or her own policy to avoid paying the claim under the policy issued by that insurer.

(e) No insurer shall:

(1) require that an automobile be repaired at a specific repair shop; or,

(2) suggest or recommend that an automobile be repaired at a specific repair shop, unless all of the requirements set forth in California Insurance Code Section 758.5 have been met.

(3) require a claimant to travel an unreasonable distance either to inspect a replacement automobile, to conduct an inspection of the vehicle, to obtain a repair estimate or to have the automobile repaired at a specific repair shop.

(f) If a partial loss is settled on the basis of a written estimate prepared by or for the insurer, the insurer shall supply the claimant with a copy of the estimate upon which the settlement is based. The estimate prepared by or for the insurer shall be of an amount that will allow for repairs to be made in accordance with accepted trade standards for good and workmanlike automotive repairs by an "auto body repair shop" as defined in section 9889.51 of the Business and Professions Code, and in accordance with the standards of automotive repair required of auto body repair shops as described in the Business and Professions Code and associated regulations, including, but not limited to, Section 3365 of Title 16 of the California Code of Regulations. An insurer shall not prepare an estimate that deviates from the standards, costs, and/or guidelines provided by the third-party automobile collision repair estimating software used by the insurer to prepare the estimate, if such deviation would result in an estimate that would not allow for repairs to be made in accordance with accepted trade standards for good and workmanlike automotive repairs by an auto body repair shop, as described in this subdivision. If the claimant subsequently contends, based upon a written estimate that he or she obtains, that necessary repairs will exceed the written estimate prepared by or for the insurer, the insurer shall:

(1) pay the difference between the written estimate and a higher estimate obtained by the claimant; or,

(2) if requested by the claimant, promptly provide the claimant with the name of at least one repair shop that will make the repairs for the amount of the insurer's written estimate. The insurer shall cause the damaged vehicle to be restored to its condition prior to the loss at no additional cost to the claimant other than as stated in the policy or as otherwise allowed by law. The insurer shall maintain documentation of all such communications; or,

(3) reasonably adjust any written estimates prepared by the repair shop of the claimant's choice and provide a copy of the adjusted estimate to the claimant and the claimant's repair shop. The adjusted estimate provided to the claimant and repair shop shall be either an edited copy of the claimant's repair shop estimate or a supplemental estimate based on the itemized copy of the claimant's repair shop estimate. The adjusted estimate shall identify the specific adjustment made to each item and the cost associated with each adjustment made to the claimant's shop's estimate.

(g) No insurer shall require the use of non-original equipment manufacturer replacement crash parts in the repair of an automobile unless all of the following conditions are met:

(1) the parts are at least equal to the original equipment manufacturer parts in terms of kind, quality, safety, fit, and performance;

(2) the insurer specifying the use of non-original equipment manufacturer replacement crash parts shall pay the cost of any modifications to the parts that may become necessary to effect the repair;

(3) the insurer specifying the use of non-original equipment manufacturer replacement crash parts warrants that such parts are at least equal to the original equipment manufacturer parts in terms of kind, quality, safety, fit, and performance. The insurer must disclose in writing, in any estimate prepared by or for the insurer, the fact that it warrants that such parts are at least equal to the original equipment manufacturer parts in terms of kind, quality, safety, fit, and performance;

(4) all original and non-original manufacturer replacement crash parts, manufactured after the effective date of this subdivision, when supplied by repair shops shall carry sufficient permanent, non-removable identification so as to identify the manufacturer. Such identification shall be accessible to the greatest extent possible after installation; and,

(5) the use of non-original equipment manufacturer replacement crash parts is disclosed in accordance with section 9875.1 of the California Business and Professions Code.

(6) If an insurer specifying the use of non-original equipment manufacturer replacement crash parts has knowledge that a part is not equal to the original equipment manufacturer part in terms of kind, quality, safety, fit, and performance, or does not otherwise comply with this section, it shall immediately cease requiring the use of the part and shall, within thirty (30) calendar days, notify the distributor of the non-compliant aspect of the part.

(7) In the repair of a particular vehicle, an insurer specifying the use of a non-original equipment manufacturer replacement crash part that is not equal to the

original equipment manufacturer part in terms of kind, quality, safety, fit, and performance, or does not otherwise comply with this section, shall pay for the costs associated with returning the part and the cost to remove and replace the non-original equipment manufacturer part with a compliant non-original equipment manufacturer part or an original equipment manufacturer part.

(8) Nothing in this subdivision prohibits an insurer from seeking reimbursement or indemnification from a third party for the costs associated with the insurer's compliance with this subdivision, including, but not limited to, costs associated with the insurer's obligation to warrant the part, modifications to the part, or returning, removing or replacing a non-compliant, non-original equipment manufacturer part. However, seeking reimbursement or indemnification from a third party shall not in any way modify the insurer's obligation to comply with this subdivision. An insurer shall retain primary responsibility to comply with this subdivision and shall not refuse or delay compliance with this subdivision on the basis that responsibility for payment or compliance should be assumed by a third party.

(h) No insurer shall require an insured or claimant to supply parts for replacement.

(i) When the amount claimed is adjusted because of betterment or depreciation, all justification shall be contained in the claim file. Any adjustments shall be discernable, measurable, itemized, and specified as to dollar amount, and shall accurately reflect the value of the betterment or depreciation. This subsection shall not preclude deduction for prior and/or unrelated damage to the loss vehicle. The basis for any adjustment shall be fully explained to the claimant in writing and shall:

(1) reflect a measurable difference in market value attributable to the condition and age of the vehicle, and

(2) apply only to parts normally subject to repair and replacement during the useful life of the vehicle such as, but not limited to, tires, batteries, et cetera.

(j) In a first party partial loss claim, the expense of labor necessary to repair or replace the damage is not subject to depreciation or betterment unless the insurance contract contains a clear and unambiguous provision permitting the depreciation of the expense of labor.

(k) After a covered loss under a policy of automobile collision coverage or automobile physical damage coverage as defined in California Insurance Code Section 660, where towing and storage are reasonably necessary to protect the vehicle from further loss, the insurer shall pay reasonable towing and storage charges incurred by the claimant. The insurer shall provide reasonable notice to the claimant before terminating payment for storage charges, so that the claimant has time to remove the vehicle from storage. This subsection shall also apply to a third party claim filed under automobile liability coverage as defined in California Insurance Code section 660, however, payment to a third party claimant may be prorated based upon the comparative fault of the parties.

**AUTHORITY:**

**Note:** Authority cited: Sections 790.10, 12921 and 12926, Insurance Code; Section 3333, Civil Code; and Sections 11152 and 11342.2, Government Code. Reference: Sections 758.5 and 790.03(c), Insurance Code; and Section 9875.1, Business and Professions Code.

**HISTORY**

1. New section filed 12-15-92; operative 1-14-93 (Register 92, No. 52).
2. Editorial correction of subsection (i) (Register 95, No. 42).
3. Amendment of section heading and section filed 1-10-97; operative 5-10-97 (Register 97, No. 2).
4. Amendment of section and Note filed 4-24-2003; operative 7-23-2003 (Register 2003, No. 17).
5. Change without regulatory effect filed 8-4-2004 depublishing the amendments to the insurance claims handling practices regulations that were approved by OAL 4-24-2003, but were enjoined in *Personal Insurance Federation and The Surety Association of America v. John Garamendi*, and reinstating replacement regulations that were either (1) in effect prior to OAL's 4-24-2003 approval of the amendments to the regulations or (2) were found by the court to be valid, as amended, all pursuant to a court-approved settlement agreement dated 6-7-2004 (Register 2004, No. 32).
6. Change without regulatory effect amending subsection (b) filed 9-15-2004 pursuant to section 100, title 1, California Code of Regulations (Register 2004, No. 38).
7. Amendment of section and Note filed 6-1-2006; operative 8-30-2006 (Register 2006, No. 22).
8. Change without regulatory effect amending subsection (b)(2) filed 3-23-2007 pursuant to section 100, title 1, California Code of Regulations (Register 2007, No. 12).
9. Amendment of subsections (f), (f)(3)-(g) and (g)(2)-(5), new subsections (g)(6)-(8) and amendment of Note, filed 12-31-2012; operative 1-30-2013 (Register 2013, No. 1).

**§ 2695.85. Auto Body Repair Consumer Bill of Rights.**

(a) Every insurer that issues automobile liability or collision insurance policies shall provide the named insured(s) with an Auto Body Repair Consumer Bill of Rights either at the time of application for an automobile insurance policy, at the time a policy is issued, or following an accident or loss that is reported to the insurer. If the insurer provides the insured with an electronic copy of a policy, the bill of rights may also be transmitted electronically. If the insurer provides the bill of rights following an accident or loss, the insurer shall also provide the bill of rights to the particular insured filing the insurance claim. If the insurer provides the bill of rights at the time of application or policy issuance, all named insureds that have not previously received the bill of rights shall be provided with a copy upon renewal of the policy.

(b) The requirements set forth in subsection 2695.85(a), above, shall apply to all automobile liability and collision insurance policies issued in California including commercial automobile, private passenger automobile, and motorcycle insurance policies.

(c) The Auto Body Repair Consumer Bill of Rights shall be a separate standardized document and plainly printed in no less than ten-point type. An insurer may distribute the form using its own letterhead, but the language of the Auto Body Repair Consumer Bill of Rights shall be developed by the California Department of Insurance and shall read as follows:

**AUTO BODY REPAIR CONSUMER BILL OF RIGHTS**

**A CONSUMER IS ENTITLED TO:**

1. SELECT THE AUTO BODY REPAIR SHOP TO REPAIR AUTO BODY DAMAGE COVERED BY THE INSURANCE COMPANY. AN INSURANCE COMPANY SHALL NOT REQUIRE THE REPAIRS TO BE DONE AT A SPECIFIC AUTO BODY REPAIR SHOP.

2. AN ITEMIZED WRITTEN ESTIMATE FOR AUTO BODY REPAIRS AND, UPON COMPLETION OF

REPAIRS, A DETAILED INVOICE. THE ESTIMATE AND THE INVOICE MUST INCLUDE AN ITEMIZED LIST OF PARTS AND LABOR ALONG WITH THE TOTAL PRICE FOR THE WORK PERFORMED. THE ESTIMATE AND INVOICE MUST ALSO IDENTIFY ALL PARTS AS NEW, USED, AFTERMARKET, RECONDITIONED, OR REBUILT.

3. BE INFORMED ABOUT COVERAGE FOR TOWING AND STORAGE SERVICES.

4. BE INFORMED ABOUT THE EXTENT OF COVERAGE, IF ANY, FOR A REPLACEMENT RENTAL VEHICLE WHILE A DAMAGED VEHICLE IS BEING REPAIRED.

5. BE INFORMED OF WHERE TO REPORT SUSPECTED FRAUD OR OTHER COMPLAINTS AND CONCERNS ABOUT AUTO BODY REPAIRS.

6. SEEK AND OBTAIN AN INDEPENDENT REPAIR ESTIMATE DIRECTLY FROM A REGISTERED AUTO BODY REPAIR SHOP FOR REPAIR OF A DAMAGED VEHICLE, EVEN WHEN PURSUING AN INSURANCE CLAIM FOR REPAIR OF THE VEHICLE.

**COMPLAINTS WITHIN THE JURISDICTION OF THE BUREAU OF AUTOMOTIVE REPAIR**

Complaints concerning the repair of a vehicle by an auto body repair shop should be directed to:

Toll Free (866) 799-3811  
California Department of Consumer Affairs  
Bureau of Automotive Repair  
10240 Systems Parkway  
Sacramento, CA 95827

The Bureau of Automotive Repair can also accept complaints over its web site at: [www.autorepair.ca.gov](http://www.autorepair.ca.gov)

**COMPLAINTS WITHIN THE JURISDICTION OF THE CALIFORNIA INSURANCE COMMISSIONER**

Any concerns regarding how an auto insurance claim is being handled should be submitted to the California Department of Insurance at:

(800) 927-HELP or (213) 897-8921  
California Department of Insurance  
Consumer Services Division  
300 South Spring Street  
Los Angeles, CA 90013

The California Department of Insurance can also accept complaints over its web site at: [www.insurance.ca.gov](http://www.insurance.ca.gov)

**AUTHORITY:**

**Note:** Authority cited: Sections 790.10, 1874.85 and 1874.87, Insurance Code. Reference: Sections 790.03(c), 790.03(h)(3) and 1874.87, Insurance Code; Sections 9884.8 and 9884.9, Business and Professions Code; and California Code of Regulations, Title 10, Chapter 5, Subchapter 7.5, Section 2695.8(j).

**HISTORY**

1. New section filed 4-24-2003; operative 7-23-2003 (Register 2003, No. 17).
2. Change without regulatory effect filed 8-4-2004 depublishing the amendments to the insurance claims handling practices regulations that were approved by OAL 4-24-2003, but were enjoined in *Personal Insurance Federation and The Surety Association of America v. John Garamendi*, and reinstating replacement regulations that were either (1) in effect prior

to OAL's 4-24-2003 approval of the amendments to the regulations or (2) were found by the court to be valid, as amended, all pursuant to a court-approved settlement agreement dated 6-7-2004 (Register 2004, No. 32).

3. Change without regulatory effect adding item 6. and amending toll free number on the Auto Body Repair Consumer Bill of Rights filed 10-

26-2009 pursuant to section 100, title 1, California Code of Regulations (Register 2009, No. 44).

4. Change without regulatory effect amending subsection (c) filed 2-3-2010 pursuant to section 100, title 1, California Code of Regulations (Register 2010, No. 6).



# TITLE 13 MOTOR VEHICLES

## DIVISION 2.

### Department of The California Highway Patrol

## CHAPTER 1.

### Licensed Stations and Muffler Installers

## ARTICLE 2.

### Exhaust System Sale and Installation

§ 611. Requirements for Certified Systems.

§ 612. Sale.

§ 613. Installation.

#### § 611. Requirements for Certified Systems.

Persons engaged in a business that involves the selling of motor vehicle exhaust systems or parts shall sell, offer for sale, or install only certified systems or parts on the following year model vehicles after the specified operative dates:

(a) Passenger Cars and Light Trucks. Systems and parts for motor vehicles (other than motorcycles and motor-driven cycles) of less than 6,000 lb (2,722 kg) gross vehicle weight rating shall comply on and after the following dates:

Year Model	Operative Date
1973 and newer	January 1, 1977
1970 and newer	July 1, 1977
1968 and newer	January 1, 1978
1967 and older	January 1, 1979

(b) Motorcycles. (This subsection is reserved until exhaust system regulations are adopted for motorcycles.)

(c) Heavy Trucks. (This subsection is reserved until exhaust system regulations are adopted for trucks with a gross vehicle weight rating of (6,000 lb [2,722 kg] or more.)

#### § 612. Sale.

No person engaged in a business that involves the selling of exhaust systems or parts shall sell or offer for sale an exhaust system or part that has not been certified by the exhaust system manufacturer or supplier in accordance with Article 11 of this title, beginning with Section 1050. This provision applies only to such systems or parts to be used on vehicles specified in Section 611.

(a) Identification Markings. All sound-modifying exhaust system parts, such as mufflers, resonators, chambered pipes, flare tips, and taper tips, sold or offered for sale after the operative dates in Section 611 shall be marked as required in Section 1054 of this title.

(b) Parts Not Required to Be Marked or Certified. Catalytic converters, manifolds, and nonchambered exhaust, tail pipes and tail pipe extensions that do not increase the noise may be sold or installed by any person without being marked or separately certified.

#### § 613. Installation.

Except as provided in the following subsections (a) and (b), no person engaged in a business that involves the selling of motor vehicle exhaust systems or parts shall sell or install on a vehicle specified in Section 611 an exhaust system or part that has not been certified for that make and model vehicle under Article 11 of this title, beginning with Section 1050. The installer shall ensure that the total exhaust noise is not significantly louder than that emitted by the exhaust system originally installed by the manufacturer on the vehicle. An exhaust system shall be considered significantly louder than the original when it is obvious to a person with normal hearing that the system produces noise that stands out above that of most vehicles of the same make and model operated on the highway.

(a) Installation on Vehicles for Which System Is Not Certified. A licensed muffler certification station having sound measuring equipment may install a certified system or part on a vehicle required to have a certified replacement system even though that system or part has not been certified for the particular make and model vehicle by the manufacturer, supplier, or seller. Such installation may be made only when the licensed station measures the sound level of the exhaust system and issues a certificate in accordance with the licensed station requirements in Article 1 of this title, beginning with Section 600.

(b) Installation on Vehicles Not Requiring Certified Replacement Systems. Any person may sell or install any certified systems or parts or uncertified systems or parts on vehicles not required by Section 611 of this title to have certified systems. Such installations shall include an adequate muffler, as required by Vehicle Code Section 27150, and shall not be a modification that increases the exhaust noise emitted by the vehicle as prohibited by Vehicle Code Section 27151.

## CHAPTER 2.

### Lighting Equipment

#### Article

1. Lighting Equipment Subject to Regulation
2. Identification Markings
3. Construction Requirements
5. Mechanical Test Requirements
7. Mounting Requirements
8. Advance Stoplamp Switches
9. Auxiliary Driving, Fog, and Passing Lamps
10. Cornering Lamps
11. Deceleration Signal Lamp Systems
12. Fog Taillamps
14. Reflex Reflectors on Front of Vehicles
15. Replacement Lenses
16. Reserve Lighting and Outage Indicating Systems
17. Running Lamps
18. School Bus Sidelamps
19. Side-Mounted and Supplemental Signal Lamps
20. Traffic Signal Priority Devices
21. Warning Lamp Flashers
22. Warning Lamps
23. School Bus Strobe Lamps

**ARTICLE 1.**

**Lighting Equipment Subject to Regulation**

- § 620. Scope of Subchapter.
- § 621. Federally Regulated Equipment.
- § 622. Equipment for Which There Is No Federal Regulation.
- § 623. Definitions.
- § 624. Referenced Publications.
- § 625. Test Data.

**§ 620. Scope of Subchapter.**

This subchapter applies to vehicle lighting equipment defined in Vehicle Code Section 375 and subject to requirements established by the department under Vehicle Code Section 26103.

**AUTHORITY:**

**Note:** Authority cited: Section 26103, Vehicle Code. Reference: Sections 21201, 21201.5, 24006, 24012, 24411, 24603, 24607, 25102.5, 25106, 25252.5, 26103, and 26104, Vehicle Code.

**HISTORY**

1. Repealer of former Subchapter 2 (Sections 620-828) and new Subchapter 2 (Sections 620-818) filed 5-29-80; designated effective 7-1-80 (Register 80, No. 22). For prior history, see Registers 67, No. 49; 68, Nos. 24 and 26; 69, Nos. 3, 16, 19, 27; 70, No. 27; 71, No. 12; 71, No. 49; 72, Nos. 15, 25, 33; 73, Nos. 22 and 47; 75, No. 42; 76, Nos. 42 and 48; 77, No. 8; and 78, No. 16.

**§ 621. Federally Regulated Equipment.**

Lighting equipment for which the department is authorized to establish requirements and for which there is a mandatory Federal Motor Vehicle Safety Standard (FMVSS) or Federal Consumer Product Safety Commission Regulation (CPSC) shall comply with the requirements in that standard or regulation. This provision applies not only to federally required original equipment devices and their replacements but also to additional devices of the same type that are not required by those standards but are regulated by the Vehicle Code. Such equipment shall be exempt from the requirements of this subchapter except for Section 625 of this Article and all of Articles 6 and 7. This provision applies to the following items:

Type of Equipment	CPSC No.	FMVSS No.
Bicycle reflectors, reflectorized pedals and reflectorized tires .....	Part 1512	----
Clearance lamps.....	108	
Emergency reflex reflectors .....	125	
Hazard warning flashers .....	108	
Hazard warning switches .....	108	
Headlamps.....	108	
License plate lamps .....	108	
Reflex reflectors.....	108	
School bus warning lamp systems .....	108	
Semiautomatic headlamp beam switching devices .....	108	
Sidemarkers lamps.....	108	

Type of Equipment	CPSC No.	FMVSS No.
Stop lamps.....	108	
Taillamps.....	108	
Turn signal flashers.....	108	
Turn signal lamps .....	108	

**AUTHORITY:**

**Note:** Authority cited: Section 26103, Vehicle Code. Reference: Sections 21201, 21201.5, 24006, 24012, 24411, 24603, 24607, 25102.5, 25106, 25252.5, 26103, and 26104, Vehicle Code.

**HISTORY**

1. Amendment of first paragraph filed 2-8-2008; operative 3-9-2008 (Register 2008, No. 6).

**§ 622. Equipment for Which There Is No Federal Regulation.**

Lighting equipment for which the department is authorized to establish requirements and for which there is no federal standard or regulation shall comply with the requirements in this subchapter. This provision applies to the following equipment:

Type of Equipment	Article
Cornering lamps.....	10
Deceleration signal systems .....	11
Driving lamps.....	9
Fog lamps .....	9
Fog taillamps.....	12
Passing lamps .....	9
Reflex reflectors on front of vehicle .....	14
Replacement lenses.....	15
Reserve lighting and outage indicating systems .....	16
Running lamps .....	17
School bus sidelamps .....	18
School bus strobe lamp .....	23
Side turn signal lamps.....	19
Supplemental stop and turn signal lamps..	19
Warning lamp flashers .....	21
Warning lamps .....	22

**AUTHORITY:**

**Note:** Authority cited: Section 26103, Vehicle Code. Reference: Sections 24006, 24012, 24411, 24603, 24607, 25102.5, 25106, 25257.7, 26103 and 26104, Vehicle Code.

**HISTORY**

1. Amendment filed 6-7-85; effective thirtieth day thereafter (Register 85, No. 23).  
 2. Amendment filed 3-8-91; operative 4-7-91 (Register 91, No. 15).

**§ 623. Definitions.**

The following definitions shall apply whenever the terms are used in this subchapter:

(a) An “aftermarket lighting device” is an item that is sold or offered for sale for use on any vehicle and includes devices of which some of the production is original equipment on specific models.



(b) "CHP" or "department" means the Department of the California Highway Patrol.

(c) An "original equipment lighting device" is an item that is factory installed on new vehicles and includes identical devices sold or offered for sale solely as replacements for the originals.

(d) A "sealed optical unit" is a lighting unit with the lens and reflector assembly permanently sealed to prevent the entrance of gas and moisture into the unit.

(e) A "semisealed optical unit" is a lighting unit with a replaceable bulb and with the lens permanently sealed to the reflector.

**AUTHORITY:**

**Note:** Authority and reference cited: Section 26103, Vehicle Code.

**§ 624. Referenced Publications.**

(a) Consumer Product Safety Commission regulations for bicycle reflex reflectors, reflectorized pedals, and reflectorized tires may be obtained at the following address: Consumer Product Safety Commission, Washington, D.C. 20207.

(b) A complete set of the Federal Motor Vehicle Safety Standards may be purchased at the following address: U.S. Government Printing Office, Washington, D.C. 20402.

Individual Federal Motor Vehicle Safety Standards may be obtained at the following address: National Highway Traffic Safety Administration, General Services Division, Room 5111C, Nassif Building, Washington, D.C. 20591.

(c) The Society of Automotive Engineers Handbook, Supplement 34, "Lighting Equipment and Photometric Tests," may be purchased at the following address: Society of Automotive Engineers, Inc., 400 Commonwealth Avenue, Warrendale, PA 15096.

**AUTHORITY:**

**Note:** Authority and reference cited: Section 26103, Vehicle Code.

**§ 625. Test Data.**

Test data referred to in Vehicle Code Section 26104 for equipment subject to regulations established by the department under Vehicle Code Section 26103 shall include the following information:

- (a) The date of the test report.
- (b) The date tests were conducted.
- (c) The standard or regulation with which the device complies.
- (d) A description of the device.
- (e) The type of material used for each major component.
- (f) Data for plastic material used in optical parts.
- (g) Where reflex sheeting is used, the sheeting manufacturer's designation for the particular material used in the device.
- (h) The bulb socket dimensions or a statement that the socket meets maximum and minimum bulb support gage requirements.
- (i) Trade number and quantity of bulbs used.
- (j) The voltage and current at which laboratory standard bulbs were operated to obtain rated mean spherical candlepower.
- (k) A list of the marks of identification, including size, location, and method of marking.

(l) Photographs or halftone prints of the assembled and disassembled device.

(m) The actual results obtained for each test or measurement required by this title or by applicable sections of Federal Motor Vehicle Safety Standards, Federal Consumer Product Safety Commission regulations, and their referenced specifications. Words such as "complies," "passed," "less than," or "more than" are not acceptable where minimum or maximum requirements are specified in measurable units, except for detailed dimensional checks of sealed lighting units and housings for such units checked by go-no-go gages.

**AUTHORITY:**

**Note:** Authority cited: Section 26103, Vehicle Code. Reference: Sections 26103 and 26104, Vehicle Code.

**ARTICLE 2.  
Identification Markings**

§ 630.	Permanent Markings.
§ 631.	Size of Markings.
§ 632.	Model Designation Markings.
§ 633.	Lens Markings.
§ 634.	Sealed Optical Unit Markings.
§ 635.	Aftermarket Housing Markings.
§ 636.	Original Equipment Housing Markings.
§ 637.	Orientation Markings.

**§ 630. Permanent Markings.**

Each lens and housing shall be permanently and legibly marked with the manufacturer's or vendor's name, initials or lettered trademark, the model designation, and other specified markings. Lens markings need not be the same as housing markings. Markings shall be imprinted on a permanently attached nameplate, die-stamped, or molded in the locations specified in this title. In lieu of other methods of marking, gaseous discharge bulbs, flashers, and the backs of sealed optical units may be marked with indelible ink.

**AUTHORITY:**

**Note:** Authority cited: Section 26103, Vehicle Code. Reference: Sections 24006 and 26103, Vehicle Code.

**§ 631. Size of Markings.**

Required markings and at least one letter of a lettered trademark shall be not less than 3.0 mm (0.12 in.) in height. Raised molded markings not less than 2.0 mm (0.08 in.) in height may be used on lenses with an area of less than 13 cm<sup>2</sup> (2 in.<sup>2</sup>) or on housings with a projected area less than 25 cm<sup>2</sup> (4 in.<sup>2</sup>). Indelible ink markings not less than 2.0 mm (0.08 in.) in height may be used on bulbs with a base diameter of less than 10.0 mm (0.40 in.).

**AUTHORITY:**

**Note:** Authority cited: Section 26103, Vehicle Code. Reference: Sections 24006 and 26103, Vehicle Code.

**§ 632. Model Designation Markings.**

All devices shall be marked with a model designation which differentiates one model from another unless they are identical except for right- and left-hand mounting, housing finish or material, number and type of bulbs or functions, or number of wiring connections to a switch. Warning lamps of the lightbar type, which are of the same design and construction except for number and

type of warning lamp or siren functions, may have the same model number provided they also have a permanently marked serial number either unique to each unit or coded to indicate the particular functions.

### § 633. Lens Markings.

Markings on the exterior lenses of lamps and reflex reflective devices and photoelectric detectors and on exterior filters or transparent covers shall be visible from the outside when the device is installed. When removal of the lens from the housing would destroy the device, either the housing or the lens may be marked if the markings differ from those previously used on any similar device.

#### AUTHORITY:

**Note:** Authority cited: Section 26103, Vehicle Code. Reference: Sections 24006 and 26103, Vehicle Code.

### § 634. Sealed Optical Unit Markings.

Sealed and semisealed optical units shall be marked on the lens with the manufacturer's name, initials, or lettered trademark and model number. Such units for driving lamps, fog lamps, and passing lamps may have the model number marked on the lens, or indelibly inked or permanently molded on the back of the unit. The model designation of a sealed warning lamp optical unit not covered by a lens or filter shall be indelibly imprinted or molded on the lens so as to be visible and legible when the device is installed.

#### AUTHORITY:

**Note:** Authority cited: Section 26103, Vehicle Code. Reference: Sections 24006 and 26103, Vehicle Code.

### § 635. Aftermarket Housing Markings.

Markings on the housing of an aftermarket lamp or reflective device shall be externally marked on the shell or other fixed part of the housing or shall be readily visible through the lens. Required markings may be placed on the door, grommet, bezel, or ornamental ring provided such part is so shaped or indexed to preclude its being installed on a housing of a different make or model. When removal of the lens from the housing would destroy the device, the housing is not required to be marked if the lens markings differ from those on any previously manufactured lens. External housing markings are not required on lamps which are packaged for sale in a disassembled condition and are marked so that the housing markings are visible when the lamp is installed on a vehicle and the lens is removed. Housings of separate control or power supply units (such as for reserve lighting and outage indicators or gaseous discharge warning lamps) shall be marked so as to be visible when the unit is installed on a vehicle.

#### AUTHORITY:

**Note:** Authority cited: Section 26103, Vehicle Code. Reference: Sections 24006 and 26103, Vehicle Code.

### § 636. Original Equipment Housing Markings.

Markings on the housing of an original equipment lamp or reflex reflective device which is factory installed on a specific motor vehicle model shall be visible when the lens is disassembled from the housing or the device is disassembled from the vehicle. Markings on original equipment housings or mounting rings for a sealed opti-

cal unit shall be visible when the unit and ornamental trim are removed. When removal of the lens from the housing would destroy the device, the housing is not required to be marked. Housings of separate control or power supply units (such as for reserve lighting and outage indicators or gaseous discharge warning lamps) shall be marked so as to be visible when the unit is installed on a vehicle.

#### AUTHORITY:

**Note:** Authority cited: Section 26103, Vehicle Code. Reference: Sections 24006 and 26103, Vehicle Code.

### § 637. Orientation Markings.

Aftermarket lamps and reflex reflectors shall be marked with the word "top" on both the exterior and interior of the housing to designate the proper mounting position, except as noted in the following subsections. The markings on the interior of the housing shall be die-stamped or molded and shall be located so as to be visible when the lens is removed.

(a) Rotated Devices. "Top" is not required on a device which meets the test requirements when it is rotated about its axis 90 and 180 deg.

(b) Housing. "Top" is not required on the housing if the lens is indexed in the housing in only one position and the word "top" is die-stamped or molded on the lens so as to be visible when the device is installed. "Top" is not required on the exterior of the housing when the interior is so marked and the lens must be removed to install the lamp on a vehicle.

(c) Sealed or Semisealed Optical Unit. "Top" is not required on the housing for any sealed or semisealed optical unit if the lens markings on the unit are right side up when the unit is in its design mounting position.

(d) Interior and Exterior. "Top" is not required on the interior of the housing if the exterior "top" marking is visible when the device is installed, nor on the exterior of the housing if the interior "top" marking is visible through the lens when the device is installed.

(e) Location. "Top" is not required at the top of the device if the word is inscribed elsewhere with an arrow pointing from "top" to the proper mounting position.

#### AUTHORITY:

**Note:** Authority cited: Section 26103, Vehicle Code. Reference: Sections 24006, 24012, and 26103, Vehicle Code.

## ARTICLE 3.

### Construction Requirements

§ 640.	Lamp Construction.
§ 641.	Optic Indexing.
§ 642.	Bulbs.
§ 643.	Bulb Sockets.
§ 644.	Translucent Housings.
§ 645.	White Light to Rear.
§ 646.	Lens Rotation and Displacement.
§ 647.	Plastic Materials.
§ 648.	Housing for Optical Units.

### § 640. Lamp Construction.

Gaskets shall be constructed of durable material which will retain its shape and resiliency. Electrical wiring shall be protected from abrasion and sharp edges.

**AUTHORITY:**

**Note:** Authority cited: Section 26103, Vehicle Code. Reference: Sections 24012 and 26103, Vehicle Code.

**§ 641. Optic Indexing.**

Lenses, interior reflectors, removable sockets, double-filament bulbs, and sealed and semisealed optical units shall be indexed into adjacent components to prevent rotation and misinstallation. Housings for sealed and semisealed optical units designed for mounting in either of two positions rotated 180 deg apart (such as fog lamps above or below a bumper) shall be indexed so the optical units are in their design position when the housing is mounted in either of the two positions. Indexing is not required for lenses that are symmetrical about the H-V axis.

**AUTHORITY:**

**Note:** Authority cited: Section 26103, Vehicle Code. Reference: Sections 24012 and 26103, Vehicle Code.

**§ 642. Bulbs.**

Sealed optical units and bulbs shall meet the requirements appropriate to the type of unit or bulb in SAE J573g, December 1976; SAE J571d, June 1976; SAE J572a, January 1972; or SAE J760a, December 1974. Sealed optical units, semisealed optical units, and bulbs of a type not listed in these SAE editions may be used provided replacements are readily available to the user.

**AUTHORITY:**

**Note:** Authority cited: Section 26103, Vehicle Code. Reference: Sections 24012 and 26103, Vehicle Code.

**§ 643. Bulb Sockets.**

Sockets for bulbs designed to comply with SAE J573g, December 1976, shall comply with SAE J567c, December 1970. Any auxiliary means employed for bulb retention and positioning in a tension socket must be of resilient construction.

**AUTHORITY:**

**Note:** Authority cited: Section 26103, Vehicle Code. Reference: Sections 24012 and 26103, Vehicle Code.

**§ 644. Translucent Housings.**

Lamps with translucent housings shall not emit to the exterior of the vehicle more than 7.75 mcd/cm<sup>2</sup> (50 mcd/in.<sup>2</sup>) of any color other than that emitted through the lens. Where the lighted section is large enough to fill a circle of at least 6.45 cm<sup>2</sup> (1.00 in.<sup>2</sup>) the limit applies to the brightest location that completely fills this size circle.

**AUTHORITY:**

**Note:** Authority cited: Section 26103, Vehicle Code. Reference: Sections 24012 and 26103, Vehicle Code.

**§ 645. White Light to Rear.**

White light which is emitted to the rear of a vehicle from the lens of any lamp other than a backup lamp shall not exceed 7.75 mcd/cm<sup>2</sup> (50 mcd/in.<sup>2</sup>) measured as described in Section 644.

**AUTHORITY:**

**Note:** Authority cited: Section 26103, Vehicle Code. Reference: Sections 24012 and 26103, Vehicle Code.

**§ 646. Lens Rotation and Displacement.**

Movement of a sealed optical unit in its housing shall not exceed  $\pm 5$  deg rotation, measured about the axis of the unit from a vertical line passing through the top of the unit. Lamps with lenses that are not located in a firmly fixed position in the housing shall comply with the photometric requirements with the lens in any position to which it can be shifted.

**AUTHORITY:**

**Note:** Authority cited: Section 26103, Vehicle Code. Reference: Sections 24012 and 26103, Vehicle Code.

**§ 647. Plastic Materials.**

Plastic materials shall meet the following requirements:

(a) **Optical Parts.** Plastic materials for optical parts of devices shall comply with SAE J576d, June 1976. Samples shall be tested either in the thickness specified in SAE J576d or in the minimum, maximum, and one intermediate thickness of the material as specified by the materials manufacturer.

(b) **Dark Filters.** Transparent material used for darkening the unlighted appearance of lamps shall meet the luminous transmittance and trichromatic coefficient requirements before and after the outdoor exposure test when used in conjunction with a colored filter that in combination meets the color requirements of SAE J578d, September 1978, before the exposure test.

(c) **Substitution of Materials.** When one of several distinctive types of plastic materials, such as polymethyl methacrylate, is acceptable under one manufacturer's designation, another material of the same type may be substituted under a different manufacturer's designation without a re-test of the device in which it is used. Plastic materials of different types, such as butyrate and polymethyl methacrylate, shall not be substituted for one another unless the device containing such substitution is retested to meet the warpage and photometric test requirements.

**AUTHORITY:**

**Note:** Authority cited: Section 26103, Vehicle Code. Reference: Sections 24012 and 26103, Vehicle Code.

**§ 648. Housing for Optical Units.**

Housing for sealed and semisealed optical units shall have mounting surfaces and retaining rings meeting the following requirements:

(a) **Seating Areas.** Seating areas on mounting rings or their equivalent shall be free of any burrs or projections that might cause unit breakage or improper seating for a distance of at least 32 mm (1.25 in.) on each side of the center of the locating notch.

(b) **Retaining rings or similar devices for holding a unit in a housing shall provide rigid retention of a unit of minimum design flange thickness.**

**AUTHORITY:**

**Note:** Authority cited: Section 26103, Vehicle Code. Reference: Sections 24012 and 26103, Vehicle Code.

## ARTICLE 5. Mechanical Test Requirements

- § 660. Applicability.  
§ 661. Aiming Adjustment Test.

§ 662.	Corrosion Test.
§ 663.	Dust Test.
§ 664.	Lens Recession Test.
§ 665.	Moisture Test.
§ 666.	Vibration Test.
§ 667.	Warpage Test.
§ 670.	Scope.
§ 671.	General Lighting Equipment.
§ 672.	Aimable Roadlighting Devices.
§ 673.	Cornering Lamps.
§ 674.	Driving Lamps.
§ 675.	Fog Lamps.
§ 676.	Headlamps, Single Filament.
§ 677.	Headlamps, Double Filament.
§ 678.	Motorcycle Headlamps.
§ 679.	Motor-Driven Cycle Headlamps.
§ 680.	Passing Lamps.
§ 681.	School Bus Sidelamps.
§ 682.	School Bus Warning Lamps.

### § 660. Applicability.

Devices shall comply with the following mechanical tests where so specified for a particular type of device.

#### AUTHORITY:

**Note:** Authority cited: Section 26103, Vehicle Code. Reference: Sections 24012 and 26103, Vehicle Code.

### § 661. Aiming Adjustment Test.

Housings for sealed and semisealed optical units, and complete assemblies for roadlighting equipment, such as driving, fog, and passing lamps, shall comply with the following aiming adjustment requirements:

(a) **Adjustment Range.** The range of adjustment from the specified aim for the lamp shall be at least  $\pm 4$  deg in both the vertical and horizontal directions. Fog lamps designed as original equipment for a specific vehicle model need have the specified range of adjustment in the vertical direction only.

(b) **Aiming Deviation.** The vertical aim of lamps with independent vertical and horizontal aiming adjustment shall not deviate more than a total of 10 cm (4.0 in.) at a distance of 7.6 m (25 ft) from the lens, when the horizontal aim is adjusted through an angle of  $\pm 4$  deg from the correct aim specified in this title. The same requirement shall apply to deviation of horizontal aim when the vertical aim is adjusted. Original equipment fog lamps with only a vertical aim adjustment shall not exceed the specified horizontal deviation when the vertical aim is adjusted through the required angle. This requirement does not apply to ball-and-socket or equivalent adjusting means.

(c) **Self-Locking Device.** Self-locking devices which hold aiming screws in position shall operate satisfactorily for 10 adjustments on each screw over a thread length of 3.0 mm (0.12 in.) inward to outward from the correct aim. This requirement does not apply to ball-and-socket or equivalent adjusting means.

#### AUTHORITY:

**Note:** Authority cited: Section 26103, Vehicle Code. Reference: Sections 24012 and 26103, Vehicle Code.

#### HISTORY

1. Amendment of subsections (a) and (b) filed 12-17-81; effective thirtieth day thereafter (Register 81, No. 51).

### § 662. Corrosion Test.

The device shall show no evidence of corrosion that would affect the proper functioning of the device when

tested in accordance with Section 4.4 of SAE J575g, September 1977.

#### AUTHORITY:

**Note:** Authority cited: Section 26103, Vehicle Code. Reference: Sections 24012 and 26103, Vehicle Code.

### § 663. Dust Test.

The device shall have no visible inside dust that results in more than a 10% reduction in maximum intensity with the outer surface cleaned as compared to the intensity after both the outer and inner surfaces are cleaned after the device is tested in accordance with Section 4.3 of SAE J575g, September 1977.

#### AUTHORITY:

**Note:** Authority cited: Section 26103, Vehicle Code. Reference: Sections 24012 and 26103, Vehicle Code.

### § 664. Lens Recession Test.

The lamp body or housing, including the aiming mechanism, when subjected to an inward force of 222 N (50 lb) directed parallel to the lamp axis and symmetrically about the center of the lens, shall meet the following requirements:

(a) **Permanent Recession.** The lens or sealed unit shall not permanently recede by more than 2.5 mm (0.10 in.).

(b) **Permanent Aim Deviation.** The aim of the lamp shall not permanently deviate by more than 32 mm (1.25 in.) at a distance of 7.6 m (25 ft).

#### AUTHORITY:

**Note:** Authority cited: Section 26103, Vehicle Code. Reference: Sections 24012 and 26103, Vehicle Code.

### § 665. Moisture Test.

The device shall not accumulate more than 2 cm<sup>3</sup> of moisture when tested in accordance with Section 4.2 of SAE J575g, September 1977.

#### AUTHORITY:

**Note:** Authority cited: Section 26103, Vehicle Code. Reference: Sections 24012 and 26103, Vehicle Code.

### § 666. Vibration Test.

The device, when tested in accordance with Section 4.1 of SAE J575g, September 1977, shall show no rotation, displacement, cracking, or rupture of parts which would result in failure of the photometric test or any other test in this article pertaining to the device, nor shall there be any cracking or rupture of parts affecting the mounting of the device. Failure of internal components of any bulb or sealed unit used in the device shall not constitute a failure unless caused by striking parts of the housing. The device shall be mounted on a stand that represents the method and position used for mounting on a vehicle. Instead of the Section 4.1 of SAE J575g, September 1977 test, devices may be tested in accordance with Section 4.1 of SAE J575f, April 1975.

#### AUTHORITY:

**Note:** Authority cited: Section 26103, Vehicle Code. Reference: Sections 24012 and 26103, Vehicle Code.

#### HISTORY

1. Amendment filed 12-17-81; effective thirtieth day thereafter (Register 81, No. 51).

**§ 667. Warpage Test.**

Lighting equipment with plastic lenses, reflectors or housings shall be subjected to warpage tests on separate samples as follows:

(a) Devices with a light source shall be mounted in normal operating position and operated at rated voltage in a circulating air cabinet for 1 h at  $49 \pm 2.8$  C ( $120 \pm 5$  F). Each device shall be operated during the test in the same manner as it will be operated in service. A cornering lap function shall be cycled 3 min on and 12 min off throughout the test.

(b) Reflex reflectors without a light source shall be mounted in normal position in a circulating air cabinet for 2 h at  $74 + 0, - 2.8$  C ( $165 + 0, - 5$  F).

(c) At the conclusion of each test, there shall be no evidence of lens, reflector, or housing warpage that would affect the proper functioning of the device.

**AUTHORITY:**

**Note:** Authority cited: Section 26103, Vehicle Code. Reference: Sections 24012, and 26103, Vehicle Code.

**§ 670. Scope.**

This article applies to the aim of lighting equipment for which the aim is not specified in the Vehicle Code.

**AUTHORITY:**

**Note:** Authority cited: Section 26103, Vehicle Code. Reference: Sections 24012 and 26103, Vehicle Code.

**§ 671. General Lighting Equipment.**

Lighting equipment other than that specified in the following sections of this article shall be aimed so the center of the beam produced by the major filament is parallel to the road and projects directly to the front, side, or rear, depending on mounting location. Adjustable warning lamps in movable spotlight type housings shall be aimed in the direction selected by the vehicle driver to provide adequate warning to other traffic.

**AUTHORITY:**

**Note:** Authority cited: Section 26103, Vehicle Code. Reference: Sections 24012 and 26103, Vehicle Code.

**§ 672. Aimable Roadlighting Devices.**

Roadlighting devices with aiming adjustment features shall, when equipped with aiming pads and aimed mechanically, be set at 0-0 with a mechanical aimer meeting SAE J602c, December 1974. Roadlighting devices visually aimed, shall be aimed as specified in the following sections of this article on a vertical aiming screen at a distance of 7.6 m (25 ft) from the front of the lens surface or with an optical aimer meeting SAE J600a, March 1965, with the aiming line on the screen adjusted to the level of the surface upon which the vehicle stands. The lamps shall be aimed with only the driver in the vehicle, except that lamps on vehicles which normally carry a load should be aimed with the vehicle so loaded. Enforcement agencies that inspect vehicles may establish aiming tolerances to allow for variations in inspection procedures and in vehicle loading.

**AUTHORITY:**

**Note:** Authority cited: Section 26103, Vehicle Code. Reference: Sections 24012 and 2103, Vehicle Code.

**§ 673. Cornering Lamps.**

Cornering lamps with means for adjusting the aim shall be aimed horizontally so the center of the high intensity portion of the beam is within 40 to 50 deg from the longitudinal axis of the vehicle toward the front. The vertical aim shall be with the center of the high intensity zone 25 to 35 cm (10 to 14 in.) below the level of the lamp center. Cornering lamps without aiming mechanisms shall be mounted in a fixed position on the vehicle in accordance with the manufacturer's instructions.

**AUTHORITY:**

**Note:** Authority cited: Section 26103, Vehicle Code. Reference: Sections 24012 and 26103, Vehicle Code.

**§ 674. Driving Lamps.**

Driving lamps shall be aimed with the center of the high intensity zone on a vertical line straight ahead of the lamp center and 5 cm (2 in.) below the level of the lamp center.

**AUTHORITY:**

**Note:** Authority cited: Section 26103, Vehicle Code. Reference: Sections 24012 and 26103, Vehicle Code.

**§ 675. Fog Lamps.**

Fog lamps shall be aimed with the center of the high intensity zone on a vertical line straight ahead of the lamp center and with the top edge of the beam 10 cm (4 in.) below the level of the lamp center.

**AUTHORITY:**

**Note:** Authority cited: Section 26103, Vehicle Code. Reference: Sections 24012 and 26103, Vehicle Code.

**§ 676. Headlamps, Single Filament.**

Single-filament upper beam sealed beam headlamp units shall be aimed with the center of the high intensity zone on a vertical line straight ahead of the lamp center and 5 cm (2 in.) below the level of the lamp center.

**AUTHORITY:**

**Note:** Authority cited: Section 26103, Vehicle Code. Reference: Sections 24012 and 26103, Vehicle Code.

**§ 677. Headlamps, Double Filament.**

Double-filament sealed beam headlamp units shall be aimed on low beam with the left edge of the high intensity zone on a vertical line straight ahead of the lamp center and with the top edge of the high intensity zone at the level of the lamp center.

**AUTHORITY:**

**Note:** Authority cited: Section 26103, Vehicle Code. Reference: Sections 24012 and 26103, Vehicle Code.

**§ 678. Motorcycle Headlamps.**

Motorcycle headlamps shall be aimed on the upper beam as specified for single-filament units in Section 676, with the vehicle upright and the wheels facing straight ahead. As an alternative, motorcycle headlamps with a well-defined lower beam may be aimed on the lower beam as specified for double-filament units in Section 677, with the vehicle upright and the front wheel facing straight ahead.

**AUTHORITY:**

**Note:** Authority cited: Section 26103, Vehicle Code. Reference: Sections 24012 and 26103, Vehicle Code.

**§ 679. Motor-Driven Cycle Headlamps.**

Motor-driven cycle headlamps shall be aimed with the vehicle upright and the front wheels facing straight ahead in accordance with the following requirements:

(a) Multiple Beam Headlamps. Multiple beam headlamps shall be aimed as specified for motorcycle headlamps.

(b) Single Beam Headlamps. Single beam headlamps shall be aimed with the center of the high intensity zone on a vertical line straight ahead of the lamp center and with the top edge of the high intensity zone at the level of the lamp center.

**AUTHORITY:**

**Note:** Authority cited: Section 26103, Vehicle Code. Reference: Sections 24012 and 26103, Vehicle Code.

**§ 680. Passing Lamps.**

Passing lamps shall be aimed with the top edge of the high intensity zone at the level of the lamp center and with the left edge of the high intensity zone 13 cm (5 in.) to the left of a vertical line straight ahead of the lamp center.

**AUTHORITY:**

**Note:** Authority cited: Section 26103, Vehicle Code. Reference: Sections 24012 and 26103, Vehicle Code.

**§ 681. School Bus Sidelamps.**

School bus sidelamps shall be aimed so the center of the high intensity portion of the beam is straight to the side of the bus and at the same height as the lamp center.

**AUTHORITY:**

**Note:** Authority cited: Sections 25102.5 and 26103, Vehicle Code. Reference: Sections 24012, 25102.5, and 26103, Vehicle Code.

**HISTORY**

1. Editorial correction of NOTE (Register 81, No. 44).

**§ 682. School Bus Warning Lamps.**

School bus warning lamps shall be aimed to comply with the following requirements:

(a) Visual Aim. When aimed visually by means of an aiming screen or optical aiming machine, the lamps shall have the center of the high intensity zone on a vertical line straight ahead of the lamp center and on a horizontal line not higher than the level of the lamp center nor lower than 10 cm (4 in.) below this level.

(b) Mechanical Aim. When aimed with a mechanical aiming machine, warning lamps with three mechanical aiming pads on the lenses shall be between 0 and 4 down on the up and down scale and at 0 on the left and right scale of the aimer.

**AUTHORITY:**

**Note:** Authority cited: Section 26103, Vehicle Code. Reference: Sections 24012 and 26103, Vehicle Code.

**ARTICLE 7.**

**Mounting Requirements**

- § 685. Installation and Maintenance.
- § 686. Mounting of Aftermarket Devices.
- § 687. Mounting of Original Equipment Devices.
- § 688. Clearance and Sidemarkers Lamps.
- § 689. Cornering Lamps.
- § 690. Deceleration Lamps.

- § 690.5. Driving Lamps.
- § 691. Fog Lamps.
- § 692. Headlamps.
- § 693. Passing Lamps.
- § 694. Running Lamps.
- § 695. School Bus Sidelamps.
- § 695.5. School Bus Strobe Lamp.
- § 696. School Bus Warning Lamps.
- § 697. Side-Mounted Turn Signal Lamps.
- § 698. Supplemental Signal Lamps.
- § 699. Turn Signal Lamps.
- § 700. Warning Lamps.

**§ 685. Installation and Maintenance.**

Lighting equipment shall be securely mounted on a rigid part of the vehicle to prevent noticeable vibration of the beam and shall be maintained with the proper aim when the vehicle is stationary and in motion. No lighting device, unless otherwise permitted, shall be mounted so any portion of the vehicle, load, or vehicle equipment interferes with the distribution of light or decreases its intensity within the photometric test angles unless an additional device is installed so the combination of the two meets these requirements. Mounting heights shall be measured from the center of the lamp or reflector to the level surface upon which the vehicle stands when it is without load.

**AUTHORITY:**

**Note:** Authority cited: Section 26103, Vehicle Code. Reference: Sections 24012 and 26103, Vehicle Code.

**§ 686. Mounting of Aftermarket Devices.**

Aftermarket lamps, with orientation markings such as “top” shall be mounted in accordance with the markings. Sealed and semisealed optical units shall be installed with the lettering on the lens face right side up. Front and rear reflex reflectors shall be securely mounted on a rigid part of the vehicle with the plane of the lens perpendicular to the roadway and parallel to the rear axle. Side reflex reflectors shall be mounted with the lens face perpendicular to the roadway and parallel to the rear wheels. Aftermarket devices with nonadjustable housings shall be mounted with the base on a horizontal or vertical surface, whichever is appropriate, unless different mounting instructions are included with such devices when offered for sale.

**AUTHORITY:**

**Note:** Authority cited: Section 26103, Vehicle Code. Reference: Sections 24012 and 26103, Vehicle Code.

**§ 687. Mounting of Original Equipment Devices.**

Original equipment lamps and reflex reflectors designed for a particular make of vehicle and installed on another vehicle shall be mounted at the same angle as on the vehicle for which they were designed. They need not be mounted at the same height or lateral spacing as on the original vehicle but must comply with the appropriate height and location limitations in this title and the Vehicle Code.

**AUTHORITY:**

**Note:** Authority cited: Section 26103, Vehicle Code. Reference: Sections 24012 and 26103, Vehicle Code.

**§ 688. Clearance and Sidemarkers Lamps.**

(a) Mounting. Clearance lamps, sidemarkers lamps, and combination clearance and sidemarkers lamps shall

be mounted as specified in FMVSS 108, except for combination clearance and sidemarker lamps on pole or pipe dollies or logging dollies which shall be mounted as required by Vehicle Code Section 25100.

(b) Exceptions. On vehicles manufactured prior to July 1, 1980, clearance lamps need not be visible at the inboard angles, and clearance and sidemarker lamps need not comply with the mounting height requirements in FMVSS 108.

(c) Specialized Lamps. Specialized combination lamps designed to be mounted with the base at angles other than 0 deg, 45 deg, or 90 deg from the longitudinal axis of the vehicle shall be installed in accordance with the manufacturer's instructions.

**AUTHORITY:**

**Note:** Authority cited: Section 26103, Vehicle Code. Reference: Sections 24012 and 26103, Vehicle Code.

**§ 689. Cornering Lamps.**

Cornering lamps shall be mounted on the front of the vehicle near the side or on the side near the front and not lower than 30 cm (12 in.) nor higher than 76 cm (30 in.).

**AUTHORITY:**

**Note:** Authority cited: Section 26103, Vehicle Code. Reference: Sections 24012 and 26103, Vehicle Code.

**§ 690. Deceleration Lamps.**

Deceleration lamps shall be mounted on the rear of the vehicle on or adjacent to the centerline of the vehicle at a height not lower than 38 cm (15 in.).

**AUTHORITY:**

**Note:** Authority cited: Section 26103, Vehicle Code. Reference: Sections 24012 and 26103, Vehicle Code.

**§ 690.5. Driving Lamps.**

Driving lamps shall be connected to the upper beam headlamp circuit so the beam changing switch will turn the lamps off when the headlamps are switched to low beam. A separate switch shall be provided to disconnect driving lamps when not in use.

**AUTHORITY:**

**Note:** Authority cited: Section 26103, Vehicle Code. Reference: Sections 24012 and 26103, Vehicle Code.

**§ 691. Fog Lamps.**

Fog lamps shall be mounted so the inner edge of the lens retaining ring is no closer than 10 cm (4 in.), or as specified by FMVSS 108 in effect at the time of vehicle manufacture, to the optical center of the front turn signal lamp.

**AUTHORITY:**

**Note:** Authority cited: Section 26103, Vehicle Code. Reference: Sections 24012, 24403 and 26103, Vehicle Code.

**HISTORY**

1. Amendment filed 6-18-92; operative 7-20-92 (Register 92, No. 25).
2. Amendment filed 2-8-2008; operative 3-9-2008 (Register 2008, No. 6).

**§ 692. Headlamps.**

Headlamps shall be mounted as specified in FMVSS 108 and as follows:

(a) Spacing. Headlamp units installed after November 15, 1975, shall not be closer to the centerline of the vehicle than 30 cm (12 in.) measured from the cen-

ter of the lens, except on motorcycles and motorized bicycles.

(b) Covers. No grille, transparent lens cover, or any other obstruction shall be in front of the headlamp lens on vehicles manufactured and first registered in California after January 1, 1968, except for headlamp concealment devices meeting FMVSS 112 that automatically move out of the way when the headlamps are turned on. Transparent lens covers are permitted in front of the headlamps of motorcycles originally equipped with such transparent covers, if the covers do not affect compliance of the headlamps with FMVSS 108.

(c) Aiming Obstructions. Headlamps on vehicles other than motorcycles shall be mounted so the plane of the aiming pads is not more than 24 cm (9.5 in.) behind the front of the vehicle for 146-mm (5 3/4-in.) headlamps and not more than 26 cm (10.2 in.) for all other headlamps in the area necessary for horizontal aiming with mechanical aiming machines. This requirement may be complied with by use of movable hood or grille components that can be opened without tools or removal of any part of the vehicle. This subsection does not apply to headlamps on authorized emergency vehicles operated by law enforcement agencies.

**AUTHORITY:**

**Note:** Authority cited: Section 26103, Vehicle Code. Reference: Sections 24012 and 26103, Vehicle Code.

**HISTORY**

1. Amendment of subsection (b) filed 10-15-91; operative 11-14-91 (Register 92, No. 6).

**§ 693. Passing Lamps.**

Passing lamps shall be mounted so the inner edge of the lens retaining ring is no closer than 10 cm (4 in.), or as specified by FMVSS 108 in effect at the time of vehicle manufacture, to the optical center of the front turn signal lamp. The lamps shall be connected to either or both the upper and lower headlamp beam circuits. A separate switch shall be provided to disconnect passing lamps not in use.

**AUTHORITY:**

**Note:** Authority cited: Section 26103, Vehicle Code. Reference: Sections 24012 and 26103, Vehicle Code.

**HISTORY**

1. Amendment filed 2-8-2008; operative 3-9-2008 (Register 2008, No. 6).

**§ 694. Running Lamps.**

Running lamps shall be mounted with one lamp at each side on the front not lower than 38 cm (15 in.) nor higher than 107 cm (42 in.). Running lamps shall be connected to turn off automatically when the headlamps are turned on. A separate switch shall be provided to turn off the running lamps any time their use is not desired during daytime.

**AUTHORITY:**

**Note:** Authority cited: Section 26103, Vehicle Code. Reference: Sections 24012 and 26103, Vehicle Code.

**§ 695. School Bus Sidelamps.**

School bus sidelamps shall be installed as follows:

(a) Location. Two lamps shall be installed on each side, one toward the front and one toward the rear, with the front sidelamp as near as practicable to the front

wheel. A third lamp may be installed near the center on buses 9.1 m (30 ft) or more in length.

(b) Spacing. Lamps on each side shall be as far apart as practicable and no closer together than 183 cm (72 in.).

(c) Height. All lamps on one side shall be at the same level, not lower than 61 cm (24 in.) nor higher than 107 cm (42 in.).

(d) Width. The lamps shall be installed so as not to exceed a total vehicle width of 2.44 m (96 in.). Installations that cause buses less than 2.03 m (80 in.) wide to equal or exceed 2.03 m (80 in.) will make necessary the installation of clearance and sidemarker lamps.

(e) Pilot Indicator. The system shall have an amber pilot indicator that is visible to the bus driver in his normal driving position and that is lighted when the sidelamps are lighted.

**AUTHORITY:**

**Note:** Authority cited: Sections 25102.5 and 26103, Vehicle Code. Reference: Sections 24012, 25102.5, and 26103, Vehicle Code.

**§ 695.5. School Bus Strobe Lamp.**

School bus strobe lamps shall be installed as follows:

(a) Location. The lamp shall be installed on the rooftop at or behind the center of the roof and equidistant from each side.

(b) Height. The top of the light-generating element inside the lamp shall not extend above the rooftop more than 1/20th of its horizontal distance from the rear of the bus. For the purpose of this section, the rear of the bus is defined as the vertical plane in contact with the rear most portion of the body. If a bus is equipped with roof mounted school bus signs or other vertical obstructions, the light-generating element may extend above the level of the signs or obstructions not to exceed 1/20th of its distance from the rear of the bus. In no case shall strobe lamps be mounted so as to exceed the maximum height limits specified in Vehicle Code Section 35250.

(c) Mounting. The vertical axis of the lamp shall be installed perpendicular to the surface of the road.

(d) Switch and Pilot Indicator. The lamp shall be activated by a manual switch labeled with the word "strobelamp," "strobe lamp," "strobe light," "strobe," or some other readily understood term which clearly and unambiguously identified the strobe light function and distinguishes it from other warning lamps and devices with which the vehicle is equipped, and independent of all other switches. In addition, the system shall have a nonglaring amber or white pilot indicator that is clearly visible to the driver and that is lighted whenever the strobe lamp is lighted.

**AUTHORITY:**

**Note:** Authority cited: Sections 25257.7 and 26103, Vehicle Code. Reference: Sections 24012, 25257.7 and 26103, Vehicle Code.

**HISTORY**

1. New section filed 3-8-91; operative 4-7-91 (Register 91, No. 15).
2. Editorial correction of NOTE (Register 91, No. 31).
3. Amendment of subsection (b) filed 9-16-94; operative 10-17-94 (Register 94, No. 37).
4. Amendment of subsection (d) filed 12-5-2000; operative 1-4-2001 (Register 2000, No. 49).

**§ 696. School Bus Warning Lamps.**

(a) Number of Lamps and Required Locations. Four warning lamps are required on each school bus. Two alternately flashing lamps shall be rigidly mounted on the front, one at each side, at the same height above the top of the windshield; and two alternately flashing lamps shall be rigidly mounted on the rear, one at each side, at the same height, with the bottom edge of each lens not lower than the top line of the side window openings. A panel shall be installed to serve as a background for warning lamps that extend above the top of a school bus.

(b) Operating Switches. School bus warning lamp switches operated manually by the driver shall be located within easy reach of the driver's position.

(c) Pilot Indicator. A bright visible flashing signal not less than 12.7 mm (0.5 in.) in diameter shall be included in the circuit to give a clear and unmistakable indication to the driver when the warning signals are turned on. The indicator shall not be obscured from the driver's view by any part of the vehicle.

(d) Spacing and Visibility. Front and rear warning lamps shall be spaced as far apart laterally as is practicable, and in no case shall the distance between lamps be less than 100 cm (39 in.). Visibility of front and rear warning lamps shall be unobstructed by any part of the vehicle from 5 deg above to 10 deg below horizontal and from 30 deg to the right to 30 deg to the left of the center line of the lamps.

(e) Warning Lamp Installation Dates. Warning lamps installed on school buses after 1965 shall be red Class C warning lamps. Those installed before 1966 and meeting requirements in effect at time of installation may continue to be used on the school buses on which they were installed.

**AUTHORITY:**

**Note:** Authority cited: Section 26103, Vehicle Code. Reference: Sections 24012, 25257 and 26103, Vehicle Code.

**HISTORY**

1. Repealer of subsection (f) filed 4-2-81; effective thirtieth day thereafter (Register 81, No. 14).
2. Amendment of subsection (b) and NOTE filed 9-6-95; operative 10-6-95 (Register 95, No. 36).

**§ 697. Side-Mounted Turn Signal Lamps.**

Side-mounted turn signal lamps permitted by Section 24953(b) of the Vehicle Code and defined by Section 791 of this title shall be mounted on either or both sides of the vehicle not lower than 50 cm (20 in.) nor higher than 183 cm (72 in.) with the lens facing the side and projecting beyond the body of the vehicle.

**AUTHORITY:**

**Note:** Authority cited: Section 26103, Vehicle Code. Reference: Sections 24012, 24953 and 26103, Vehicle Code.

**HISTORY**

1. Amendment filed 4-5-83; effective thirtieth day thereafter (Register 83, No. 15).

**§ 698. Supplemental Signal Lamps.**

(a) Supplemental combination stop and turn signal lamps permitted by Section 24603(g) of the Vehicle Code and supplemental rear turn signal lamps permitted by Section 24953(c) of the Vehicle Code and defined by Section 791 of this title shall be mounted near either or both sides of the vehicle facing the rear.



(b) Supplemental stop lamps shall be mounted near the side of the vehicle or on or near the vertical centerline of the vehicle.

(c) When more than one lamp is mounted on the rear of the vehicle, the lamps shall be at the same height and equally spaced from the vertical centerline of the vehicle.

**AUTHORITY:**

**Note:** Authority cited: Section 26103, Vehicle Code. Reference: Sections 24012, 24603, 24953 and 26103, Vehicle Code.

**HISTORY**

1. Amendment filed 4-5-83; effective thirtieth day thereafter (Register 83, No. 15).

**§ 699. Turn Signal Lamps.**

Turn signal lamps shall be mounted and operated as follows:

(a) Motor Vehicles. Turn signal systems on motor vehicles shall consist of at least two single-faced or double-faced turn signal lamps on or near the front and at least two single-faced turn signal lamps on the rear. Double-faced turn signal lamps shall be mounted ahead of the center of the steering wheel or the center of the outside rearview mirror, whichever is rearmost. A truck-tractor or a truck chassis without body or load may be equipped with one double-faced turn signal lamp on each side in lieu of the four separate lamps otherwise required on a motor vehicle. Front and rear turn signal lamps on motorcycles shall be at least 23 cm (9 in.) apart, except that front turn signals on motorcycles manufactured after January 1, 1973, shall be at least 40 cm (16 in.) apart. Turn signal lamps on other vehicles shall be spaced as far apart as practical. The optical axis of the front turn signal lamp shall be at least 10 cm (4 in.), or as specified by FMVSS 108 in effect at the time of vehicle manufacture, from the inside diameter of the retaining ring of the lower beam headlamp unit, fog lamp unit or passing lamp unit. Additional turn signal lamps may be mounted closer than the 10 cm (4 in.) dimension provided the primary lamps equal or exceed that distance. Original equipment turn signals that emit two and one-half times the minimum candela requirements may be closer.

(b) Towed Vehicles. The rearmost vehicle in a combination of vehicles shall be equipped with at least two single-faced turn signal lamps on the rear. The signal system on a combination of vehicles towed by a motor vehicle equipped with double-faced front turn signal lamps may be connected so only the double-faced turn signal lamps on the towing vehicle and the signal lamps on the rear of the rearmost vehicle are operative. Towed vehicles not required to be equipped with turn signals by Vehicle Code Section 24951(b) shall be equipped with rear turn signal lamps when turn signal lamps are required or used in lieu of hand and arm signals under Vehicle Code Section 22110. Such lamps are not required on the following vehicles when the rear signal lamps on the preceding vehicle in the combination can be seen by a following driver from straight to the rear of the lamp to 45 deg outboard:

Vehicles with a gross weight of less than 2722 kg (6,000 lb)

- Special mobile equipment
- Pole and pipe dollies
- Logging dollies

**Auxiliary dollies**

(c) Operation. Turn signal lamps visible to approaching or following drivers shall flash in unison, except that a turn signal consisting of two or more units mounted horizontally may flash in sequence from inboard to outboard. The lamps may be either extinguished simultaneously or lighted simultaneously. Turn signal lamps shall flash at a rate of 60 to 120 flashes per minute.

(d) Pilot Indicator. An effective visual signal operating at the same rate as the turn signal flasher shall be incorporated in the circuit to give clear and unmistakable indication to the driver that the turn signal lamps are turned on. Failure of one or more turn signals to operate shall be indicated by a steady-on, steady-off, or significant change in the flashing rate of the illuminated indicator, except on combinations of vehicles using a variable load flasher.

(e) Visibility. Lamps shall be mounted so the signal light from at least one lamp on each side is visible from directly to the front or rear within a 45-deg outboard angle on its side of the vehicle. Within these angles, no part of the vehicle or load shall obstruct the lamp from the view of another driver. On combinations of vehicles, rear turn signal lamps on other than the rearmost vehicle shall be mounted so that at least one lamp at each side is not obstructed by any towed vehicle within angles of 10 to 45 deg on its side of the vehicle.

(f) Mounting Height. Required turn signal lamps shall be mounted at a height not less than 38 cm (15 in.) nor higher than 2.1 m (83 in.). A turn signal function may be combined in the high mounted stoplamps permitted on tow trucks by Vehicle Code Section 24603.

**AUTHORITY:**

**Note:** Authority cited: Section 26103, Vehicle Code. Reference: Sections 24012 and 26103, Vehicle Code.

**HISTORY**

1. Amendment of subsection (a) filed 2-8-2008; operative 3-9-2008 (Register 2008, No. 6).

**§ 700. Warning Lamps.**

Required front warning lamps other than school bus warning lamps, shall be mounted so the entire projected area of the lens is visible from all eye heights of drivers of other vehicles at angles within 45 deg left to 45 deg right of the front of the vehicle. If the light within these required angles is blocked by the vehicle or any substantial object on it, an additional warning lamp shall be displayed within the obstructed angle. Warning lamps may be mounted at any height.

**AUTHORITY:**

**Note:** Authority cited: Section 26103, Vehicle Code. Reference: Sections 24012 and 26103, Vehicle Code.

**ARTICLE 8.**

**Advance Stoplamp Switches**

**AUTHORITY:**

**Note:** Authority cited: Section 26103, Vehicle Code. Reference: Sections 24012, 24603 and 26103, Vehicle Code.

**HISTORY**

1. Repealer of Article 8 (Sections 705-707) filed 6-7-85; effective thirtieth day thereafter (Register 85, No. 23). For prior history, see Register 84, No. 2.

**ARTICLE 9.**

**Auxiliary Driving, Fog, and Passing Lamps**

- § 710. Scope.
- § 711. Mechanical Test Requirements.
- § 712. Photometric Test Requirements.
- § 713. Beam Aimability Requirements.

**§ 710. Scope.**

This article applies to driving lamps, fog lamps, and passing lamps permitted by Vehicle Code Sections 24402 and 24403.

**AUTHORITY:**

**Note:** Authority cited: Section 26103, Vehicle Code. Reference: Sections 24012, 26103 and 26104, Vehicle Code.

**§ 711. Mechanical Test Requirements.**

Auxiliary lamps shall meet the following mechanical test requirements:

(a) Housings for Sealed or Semisealed Optical Units. Housings for sealed or semisealed optical units shall comply with the following tests described in Article 5 of this subchapter when an optical unit of the type for which the housing is designed is installed in the device:

- Aiming adjustment
- Corrosion
- Lens recession
- Vibration
- Warpage (when plastic housings are used)

(b) Complete Assemblies. Assemblies consisting of a housing with a nonsealed unit or separable bulb, lens, or reflector shall comply with the following tests described in Article 5 of this subchapter:

- Aiming adjustment
- Corrosion
- Dust
- Lens recession
- Moisture
- Vibration
- Warpage (when plastic lenses or housings are used)

(c) Sealed or Semisealed Optical Units. Sealed or semisealed optical units shall comply with the following tests described in Article 5 of this subchapter:

- Corrosion (when metal reflector backs or replaceable bulbs are used)
- Vibration (when filament shields or replaceable bulbs are used)
- Warpage (when plastic lenses or reflectors are used)

**AUTHORITY:**

**Note:** Authority cited: Section 26103, Vehicle Code. Reference: Sections 24012 and 26103, Vehicle Code.

**§ 712. Photometric Test Requirements.**

Photometric tests shall be made with the filament in the design position. For unsealed and semisealed driving and passing lamps, tests shall also be made in the out-of-focus positions listed in Section 654 of this title. The luminous intensity of a single lamp tested as specified in Article 4 of this subchapter shall be as follows with a reaim tolerance of 0.25 deg allowed at any test point:

(a) Driving Lamps. Driving lamps shall meet the photometric requirements in Table I when the lamps are aimed as specified in Article 6 of this subchapter.

**TABLE I. PHOTOMETRIC REQUIREMENTS FOR DRIVING LAMPS**

Test point coordinates		Cd	
Vertical	Horizontal	Max	Min
3U	3L-3R	5,000	--
2U	3L-3R	8,000	--
IU	3L-3R	25,000	--
H	V	50,000	20,000
H	3L-3R	--	10,000
1D	6L-6R	--	3,700
2D	6L-6R	--	2,000

(b) Fog Lamps. Fog lamps shall meet the photometric requirements in SAE J583d, July 1977, SAE J583, JUN93, or SAE J583, APR2001.

(c) Passing Lamps. Passing lamps shall meet the photometric requirements in SAE J582a, January 1973.

**AUTHORITY:**

**Note:** Authority cited: Section 26103, Vehicle Code. Reference: Sections 24012 and 26103, Vehicle Code.

**HISTORY**

1. Amendment of first paragraph and subsection (b) filed 6-12-95; operative 7-12-95 (Register 95, No. 24).
2. Amendment of subsection (b) filed 7-16-2004; operative 8-15-2004 (Register 2004, No. 29).

**§ 713. Beam Aimability Requirements.**

Driving, fog, and passing lamps shall be centered on a goniometer, operated at design voltage, and aimed in a dark room on a perpendicular screen 7.5 m (25 ft) from the lamp. The goniometer shall be adjusted until the observer considers the visual aim on the screen to be correct in accordance with Sections 674, 675, or 680 of this title. Each of three experienced observers shall aim the lamp at least three times and each observer's goniometer settings shall be individually averaged. The deviation of each observer's averaged reading from that of any other observer shall not be more than 0.2 deg in the vertical direction and 0.4 deg in the horizontal direction.

**AUTHORITY:**

**Note:** Authority cited: Section 26103, Vehicle Code. Reference: Sections 24012 and 26103, Vehicle Code.

**ARTICLE 10.  
Cornering Lamps**

- § 720. Scope.
- § 721. Mechanical Test Requirements.
- § 722. Photometric Test Requirements.

**§ 720. Scope.**

This article applies to cornering lamps permitted by Vehicle Code Section 25107.

**AUTHORITY:**

**Note:** Authority cited: Section 26103, Vehicle Code. Reference: Sections 24012, 26103, and 26104, Vehicle Code.

**§ 721. Mechanical Test Requirements.**

Cornering lamps shall meet the following mechanical test requirements in Article 5 of this subchapter:

- Corrosion
- Dust

Moisture  
Vibration

Warpage (for plastic lenses and housings)

None of the above tests are required on all-glass sealed optical units, and the dust and moisture tests are not required on housings for all-glass units.

**AUTHORITY:**

**Note:** Authority cited: Section 26103, Vehicle Code. Reference: Sections 24012 and 26103, Vehicle Code.

**§ 722. Photometric Test Requirements.**

Cornering lamps shall meet the photometric requirements in SAE J852b, February 1965, when tested as specified in Article 4 of this subchapter.

**AUTHORITY:**

**Note:** Authority cited: Section 26103 Vehicle Code. Reference: Sections 24012 and 26103, Vehicle Code.

**ARTICLE 11.**

**Deceleration Signal Lamp Systems**

§ 730. Scope.  
§ 731. Operating Requirements.

**§ 730. Scope.**

This article applies to deceleration signal lamp systems permitted by Vehicle Code Section 25251.5.

**AUTHORITY:**

**Note:** Authority cited: Section 26103, Vehicle Code. Reference: Sections 24012, 26103 and 26104, Vehicle Code.

**§ 731. Operating Requirements.**

Deceleration signal systems shall meet the following operating requirements:

(a) Function. The system shall operate so as to indicate a component of deceleration of the vehicle on which it is installed by varying the flashing rate of a yellow lamp when the service brakes are applied.

(b) Reduced Nighttime Brightness. The system shall incorporate an automatic means for reducing the intensity of the lamp during darkness. The system shall cause the voltage to the deceleration lamps to decrease to 5.0 V  $\pm$ 10% at 0 g deceleration during darkness. The specified voltage shall be reached when the illumination on the sensor is not more than 53.8 lm/m<sup>2</sup> (5 lm/ft<sup>2</sup>) nor less than 5.4 lm/m<sup>2</sup> (0.5 lm/ft<sup>2</sup>).

**AUTHORITY:**

**Note:** Authority cited: Section 26103, Vehicle Code. Reference: Sections 24012 and 26103, Vehicle Code.

**ARTICLE 12.**

**Fog Taillamps**

§ 740. Scope.  
§ 741. General Requirements.  
§ 742. Mechanical Test Requirements.

**§ 740. Scope.**

This article applies to fog taillamps permitted by Vehicle Code Section 24602.

**AUTHORITY:**

**Note:** Authority cited: Section 26103, Vehicle Code. Reference: Sections 24012, 26103 and 26104, Vehicle Code.

**§ 741. General Requirements.**

Fog taillamps shall not be optically combined with any lighting function other than a tail lamp or reflex reflector. The projected luminous lens area in the H-V direction shall not exceed 140 cm<sup>2</sup> (21.7 in.<sup>2</sup>).

**AUTHORITY:**

**Note:** Authority cited: Section 26103, Vehicle Code. Reference: Sections 24012 and 26103, Vehicle Code.

**§ 742. Mechanical Test Requirements.**

Fog taillamps shall meet the following mechanical test requirements in Article 5 of this subchapter:

Corrosion  
Dust  
Moisture  
Vibration  
Warpage (for plastic lenses or housings).

**AUTHORITY:**

**Note:** Authority cited: Section 26103, Vehicle Code. Reference: Sections 24012 and 26103, Vehicle Code.

**ARTICLE 14.**

**Reflex Reflectors on Front of Vehicles**

§ 760. Scope.  
§ 761. Definitions.  
§ 762. Test Requirements.

**§ 760. Scope.**

This article applies to reflex reflectors permitted on the front of vehicles by Vehicle Code Section 24609 and not governed by FMVSS 108.

**AUTHORITY:**

**Note:** Authority cited: Section 26103, Vehicle Code. Reference: Sections 24012, 26103 and 26104, Vehicle Code.

**§ 761. Definitions.**

(a) "Area reflectorizing material," referred to in Vehicle Code Section 25500, is nonrigid retroreflecting sheeting or tape that may be affixed to a vehicle by means of an adhesive backing.

(b) A "reflector" or "reflex reflector" is a rigid device that returns light from various angles of incidence in a direction close to that at which it is incident and which may be affixed to a vehicle by adhesive or mechanical means.

**AUTHORITY:**

**Note:** Authority and reference cited: Section 26103, Vehicle Code.

**§ 762. Test Requirements.**

Front reflex reflectors shall meet the reflex reflector requirements of FMVSS 108, except that white reflectors shall meet the photometric requirements in SAE J594e, March 1970.

**AUTHORITY:**

**Note:** Authority cited: Section 26103, Vehicle Code. Reference: Sections 24012 and 26103, Vehicle Code.

**HISTORY**

1. Amendment filed 12-17-81; effective thirtieth day thereafter (Register 81, No. 51).

**ARTICLE 15.  
Replacement Lenses**

- § 765. Scope.
- § 766. Definition.
- § 767. Mechanical Test Requirements.
- § 768. Photometric Test Requirements.
- § 769. Installation Instructions.

**§ 765. Scope.**

This article applies to replacement lenses for lighting equipment subject to requirements established by the department, including replacement lenses manufactured solely for installation by private individuals on lighting equipment regulated by FMVSS 108.

**AUTHORITY:**

**Note:** Authority cited: Section 26103, Vehicle Code. Reference: Sections 24012, 26103 and 26104, Vehicle Code.

**§ 766. Definition.**

A “replacement lens” is a lens manufactured by a firm other than the manufacturer of the original lens for a lighting device.

**AUTHORITY:**

**Note:** Authority and reference cited: Section 26103, Vehicle Code.

**§ 767. Mechanical Test Requirements.**

Replacement lenses, when installed in the appropriate housings, shall meet the following mechanical test requirements in Article 5 of this subchapter:

- Dust
- Moisture
- Vibration

Warpage (for plastic lenses of devices not governed by FMVSS 108)

If lenses are supplied with gaskets, seals, or miscellaneous parts, lamps shall be assembled and tested with those parts. If lenses are not supplied with additional parts, the tests shall be conducted with the type used with the original housing model.

**AUTHORITY:**

**Note:** Authority cited: Section 26103, Vehicle Code. Reference: Sections 24012 and 26103, Vehicle Code.

**§ 768. Photometric Test Requirements.**

Replacement lenses shall be tested in a sample lamp housing of the latest model for which they were designed and shall meet the photometric requirements for each function performed that were in effect at the time the latest lamp was last manufactured.

**AUTHORITY:**

**Note:** Authority cited: Section 26103, Vehicle Code. Reference: Sections 24012 and 26103, Vehicle Code.

**§ 769. Installation Instructions.**

Instructions listing the original lamps or year and model of the vehicles on which replacement lenses are designed to be installed shall be included with the lens, printed on the box containing the lens, or listed in a readily available catalog at the place the lens is sold or offered for sale.

**AUTHORITY:**

**Note:** Authority cited: Section 26103, Vehicle Code. Reference: Sections 24006, 24012 and 26103, Vehicle Code.

**ARTICLE 16.  
Reserve Lighting and Outage Indicating Systems**

- § 770. Scope.
- § 771. Definition.
- § 772. General Requirements.
- § 773. Operating Requirements.
- § 774. Voltage Requirements for Alternate Circuits.
- § 775. Vibration Test Requirements.
- § 776. Temperature Test Requirements.
- § 777. Installation Requirements.

**§ 770. Scope.**

This article applies to reserve lighting and outage indicating systems on vehicles for regulating the light sources of lamps. Lamp monitoring systems which do not compensate for failure of the required lighting equipment are not within the scope of this regulation.

**AUTHORITY:**

**Note:** Authority cited: Section 26103, Vehicle Code. Reference: Sections 24012, 26103 and 26104, Vehicle Code.

**§ 771. Definition.**

A “reserve lighting and outage indicating system” is a system that indicates partial or total failure of the lighting equipment on a vehicle and automatically compensates for such failure by energizing inactive lamp filaments to substitute for the required function until repairs can be made.

**AUTHORITY:**

**Note:** Authority and reference cited: Section 26103, Vehicle Code.

**§ 772. General Requirements.**

(a) Operating Unit. The operating unit may consist of individual circuits to operate only the headlamps or only the taillamps. If the operating unit combines both circuits, it shall have independent headlamp and rear lamp circuits so that failure in one circuit will not affect the other circuit.

(b) Outage Indicators. Outage shall be indicated by two separate lamps, one each for the headlamp and the rear lighting circuits. Required visual indicators may be supplemented by audible indicators. Each required indicator shall consist of a lamp with an illuminated area not less than that of a circle with a 4.8-mm (0.19-in.) diameter, and each indicator shall give a clear and unmistakable signal to the driver as follows:

(1) Headlamp Circuits. One white lamp shall indicate outage in the upper or the lower beam headlamp circuit, whichever is in use.

(2) Rear Lamp Circuits. One red lamp shall indicate outage in the taillamp circuit or failure of the stoplamp fuse or switch. For multicompartmen t or multiple rear lamps, only the outboard sections or lamps need an outage indicator.

(c) Wiring Connectors. The device shall have wiring connectors to make all necessary electrical connections between the device and the vehicle lighting system by plug-in means at existing plug-in terminal junctions. For vehicles not equipped with plug-in terminal junctions, a plug-in terminal shall be installed to make all necessary connections to the vehicle lighting system.

(d) Fail-Safe Operation. Failure of the device shall not result in failure of the normal lighting system.

**AUTHORITY:**

**Note:** Authority cited: Section 26103, Vehicle Code. Reference: Sections 24012 and 26103, Vehicle Code.

**§ 773. Operating Requirements.**

(a) Normal Operation. When headlamps are operating normally, the headlamp outage indicator shall operate at not less than 10% nor more than 20% of the normal voltage used to indicate an outage. When taillamps are operating normally, the rear lamp outage indicator shall operate only when the foot brake is applied.

(b) Circuit Failure. When lamps are turned on, the outage system shall respond to circuit failure by continuing the normal display of any unfailed lamp, energizing the appropriate inactive lamp filaments, and indicating the failure to the driver. A "headlamp circuit failure" exists when one-half or more of the upper or lower beam filaments have failed. A "taillamp circuit failure" exists when one-half or more of the taillamp filaments have failed. A "stoplamp circuit failure" exists when the stoplamp switch or fuse fails.

(c) Headlamp Outage. Failure in the lower beam headlamp as defined in preceding subsection (b) shall cause the outage system to activate the upper beam circuit at a decreased voltage. Failure in the upper beam headlamp shall cause the outage system to activate the lower beam circuit at a decreased voltage. Such failure in lower or upper headlamp beam shall be indicated by the continuous steady-on or flashing of the headlamp circuit outage indicator.

(d) Taillamp Outage. Failure of the taillamp circuit shall cause the outage system to activate the stoplamp circuit at a decreased voltage. Such failure shall be indicated by the continuous steady-on or flashing of the rear lighting outage indicator at not more than one-third of its normal brilliancy.

(e) Stoplamp Outage. Normal activation of the stoplamp circuit shall operate the rear lighting indicator at normal brilliancy during application of the service brake. Failure of the stoplamp filament, switch, or fuse shall cause loss of this indication.

(f) Alternate Circuit. Reserve lamps in the alternate circuit shall be capable of automatically performing the design function as well as compensating for the outage.

(g) Operating Unit Voltage Drop. Voltage drops across headlamp and rear lamp sections of the operating unit shall not exceed the following values for each normally operating function when the lamps are operated at design voltage:

- 0.40 V for two lamps
- 0.45 V for three lamps
- 0.50 V for four lamps
- 0.60 V for six lamps or more

**AUTHORITY:**

**Note:** Authority cited: Section 26103, Vehicle Code. Reference: Sections 24012 and 26103, Vehicle Code.

**§ 774. Voltage Requirements for Alternate Circuits.**

When the alternate circuit lamps are connected and the design voltage is applied to the input terminals of the device, voltages at output terminals shall be as follows:

(a) Headlamps--Lower Beam Outage Compensated by Upper Beam. Voltage to the upper beam filaments as reserve lower beam headlamps when one-half or more

of the lower beam filaments fail shall be not more than 50% nor less than 40% of the design voltage of the upper beam filament.

(b) Headlamps--Upper Beam Outage Compensated by Lower Beam. Voltage to the lower beam filaments as reserve upper beam headlamps when one-half or more of the upper beam filaments fail shall be not less than 75% of the design voltage of the lower beam filament.

(c) Taillamps--Outage Compensated by Stoplamps. Voltage to the stoplamp filaments as reserve taillamps shall be not more than 50% nor less than 40% of the design voltage of the stoplamp filament.

**AUTHORITY:**

**Note:** Authority cited: Section 26103, Vehicle Code. Reference: Sections 24012 and 26103, Vehicle Code.

**§ 775. Vibration Test Requirements.**

Sensing and control units shall meet the following vibration test requirements under 5 g constant acceleration:

(a) The device shall be mounted in design position and vibrated for 30 min in each of three directions: vertical, horizontal and normal to the vehicle, and horizontal and parallel to the vehicle axis.

(b) The vibration frequency shall be varied from 30 to 200 to 30 Hz over a period of approximately 1 min.

(c) The device shall be operated with all lamps at design voltage during the vibration test.

(d) At the conclusion of the test, the system shall meet all the requirements of Sections 773 and 774.

**AUTHORITY:**

**Note:** Authority cited: Section 26103, Vehicle Code. Reference: Sections 24012 and 26103, Vehicle Code.

**§ 776. Temperature Test Requirements.**

Sensing and control units shall be mounted in their normal operating positions in a circulating air cabinet for 1 h at an ambient temperature of 74 + 0, -2.8°C (165 + 0, -5°F). After the temperature conditioning, the system shall meet all the requirements of Sections 773 and 774 over a temperature range of -34 to +38°C (-30 to +100°F).

**AUTHORITY:**

**Note:** Authority cited: Section 26103 Vehicle Code. Reference: Sections 24012 and 26103, Vehicle Code.

**§ 777. Installation Requirements.**

Reserve lighting and outage indicating systems shall meet the following installation requirements:

(a) Outage Indicator Location. Outage indicator lamps shall be mounted where they are clearly visible to the driver.

(b) Connection to Vehicle Lighting System. After market installation and connection of the device to the vehicle lighting system shall be as follows:

(1) Headlamp Section. The headlamp section shall be connected into the headlamp upper and lower beam circuits at the beam changing switch.

(2) Rear Lighting Section. The taillamp element of the rear lighting section shall be series-connected in the taillamp circuit between the switch and the lamps, and the stoplamp element shall be series-connected in the stoplamp circuit immediately following the stoplamp switch.

**AUTHORITY:**

**Note:** Authority cited: Section 26103, Vehicle Code. Reference: Sections 24012 and 26103, Vehicle Code.

**ARTICLE 17.  
Running Lamps**

- § 780. Scope.
- § 781. Minimum Size.
- § 782. Mechanical Test Requirements.

**§ 780. Scope.**

This article applies to running lamps permitted by Vehicle Code Section 25100.

Running lamps may meet either the requirements of this article or Federal Motor Vehicle Safety Standard 108 effective February 10, 1993.

**AUTHORITY:**

**Note:** Authority cited: Section 26103, Vehicle Code. Reference: Sections 24102, 26103 and 26104, Vehicle Code.

**HISTORY**

1. Change without regulatory effect amending section filed 9-9-93 pursuant to title 1, section 100, California Code of Regulations (Register 93, No. 37).

**§ 781. Minimum Size.**

Running lamps shall have an effective projected luminous area of at least 78 cm<sup>2</sup> (12 in.<sup>2</sup>).

**AUTHORITY:**

**Note:** Authority cited: Section 26103, Vehicle Code. Reference: Sections 24012 and 26103, Vehicle Code.

**§ 782. Mechanical Test Requirements.**

Running lamps shall meet the following mechanical test requirements:

(a) Housings for Sealed and Semisealed Optical Units. Housings for sealed or semisealed optical units shall comply with the following tests described in Article 5 of this subchapter:

- Corrosion
- Vibration
- Warpage (when plastic housings are used)

(b) Complete Assemblies. Assemblies consisting of a housing with a nonsealed unit or separable bulb, lens, or reflector shall comply with the following tests described in Article 5 of this subchapter:

- Corrosion
- Dust
- Moisture
- Vibration
- Warpage (when plastic lenses or housings are used)

(c) Sealed or Semisealed Optical Units. Sealed or semisealed optical units shall comply with the following tests described in Article 5 of this subchapter:

- Corrosion (when metal reflector backs or replaceable bulbs are used)
- Vibration (when filament shields or replaceable bulbs are used)
- Warpage (when plastic lenses or reflectors are used)

**AUTHORITY:**

**Note:** Authority cited: Section 26103, Vehicle Code. Reference: Sections 24012 and 26103, Vehicle Code.

**ARTICLE 18.  
School Bus Sidelamps**

- § 785. Scope.
- § 786. General Requirements.

**§ 785. Scope.**

This article applies to lamps permitted on the sides of school buses by Vehicle Code Section 25102.5.

**AUTHORITY:**

**Note:** Authority cited: Sections 25102.5 and 26103, Vehicle Code. Reference: Sections 24012, 25102.5, 26103 and 26104, Vehicle Code.

**§ 786. General Requirements.**

School bus sidelamps shall be any of the following types of devices meeting their respective requirements in FMVSS 108 or this title. Housings shall meet the requirements for headlamp, driving lamp, or passing lamp housings, and optical units shall be of the following types:

- (a) Single- or double-filament sealed beam headlamp unit with the words "Sealed Beam" molded on the face of the lens. Double-filament units shall have both beams burning.
- (b) Sealed driving lamp unit
- (c) Sealed passing lamp unit

**AUTHORITY:**

**Note:** Authority cited: Sections 25102.5, and 26103, Vehicle Code. Reference: Sections 24012, 25102.5 and 26103, Vehicle Code.

**ARTICLE 19.  
Side-Mounted and Supplemental Signal Lamps**

- § 790. Scope.
- § 791. Definitions.
- § 792. General Requirements.
- § 793. Mechanical Test Requirements.
- § 794. Photometric Test Requirements.

**§ 790. Scope.**

This article applies to supplemental turn signal lamps, supplemental stop lamps, and side-mounted turn signal lamps governed by Vehicle Code Sections 24603 and 24953.

**AUTHORITY:**

**Note:** Authority cited: Section 26103, Vehicle Code. Reference: Sections 24012, 26103 and 26104, Vehicle Code.

**HISTORY**

1. Amendment filed 4-5-83; effective thirtieth day thereafter (Register 83, No. 15).

**§ 791. Definitions.**

(a) Side-Mounted Turn Signal Lamp. A "side-mounted turn signal lamp" is a lighting device designed to be used in addition to the required turn signals to give a flashing signal on the side toward which the driver intends to turn or move.

(b) Supplemental Stoplamp. A "supplemental stoplamp" is a lamp that operates simultaneously with and in addition to the required stoplamp.

(c) Supplemental Rear Turn Signal Lamp. A "supplemental rear turn signal lamp" is a lamp that operates simultaneously with, on the same side as, and in addition to a required rear turn signal lamp.

**AUTHORITY:**

**Note:** Authority and reference cited: Section 26103, Vehicle Code.

**HISTORY**

1. Amendment filed 4-5-83; effective thirtieth day thereafter (Register 83, No. 15).
2. Amendment filed 1-8-2001; operative 2-7-2001 (Register 2001, No. 2).

**§ 792. General Requirements.**

(a) Combination Lamp Requirements. Side mounted and supplemental turn signal lamps may be combined with sidemarker lamps if the requirements for each lamp are met.

(b) Use of Alternative Lamp Requirements. Notwithstanding Section 794 of this title, lamps meeting the requirements for stop or turn signal lamps may be used as supplemental stop lamps or supplemental turn signal lamps.

(c) Simultaneous Flash Requirements. If side-mounted turn signal lamps flash when the hazard warning switch is activated, all such lamps shall flash simultaneously with the rear turn signal lamps. On vehicles equipped with sequential turn signal lamps, side-mounted turn signal lamps shall flash simultaneously with the front; turn signal lamps.

(d) Grandfathered Lighting Requirements. Side-mounted turn signal lamps installed before January 1, 1967, may be yellow turn signal lamps or yellow combination clearance and sidemarker lamps.

**AUTHORITY:**

**Note:** Authority cited: Section 26103, Vehicle Code. Reference: Sections 24012, 24603, 24953 and 26103, Vehicle Code.

**HISTORY**

1. Amendment filed 4-5-83; effective thirtieth day thereafter (Register 83, No. 15.)
2. Repealer and new subsection (a), repealer of subsection (c) and subsection relettering filed 6-23-92; operative 7-23-92 (Register 92, No. 26).
3. Amendment filed 1-8-2001; operative 2-7-2001 (Register 2001, No. 2).

**§ 793. Mechanical Test Requirements.**

Side-mounted turn signal lamps and supplemental stop or turn signal lamps shall meet the following mechanical test requirements in Article 5 of this chapter:

- (a) Corrosion
- (b) Dust
- (c) Moisture
- (d) Vibration
- (e) Warpage (for plastic lenses and housings).

**AUTHORITY:**

**Note:** Authority cited: Section 26103, Vehicle Code. Reference: Sections 24012, 26103 and 26104, Vehicle Code.

**HISTORY**

1. Amendment filed 1-8-2001; operative 2-7-2001 (Register 2001, No. 2).

**§ 794. Photometric Test Requirements.**

Side-mounted turn signal lamps and supplemental stop or turn signal lamps shall meet the following photometric requirements when tested as specified in Article 4 of this chapter:

(a) Standards for Side-Mounted Turn Signal Lamps. Side-mounted turn signal lamps shall meet one or more of the following standards, as appropriate for the vehicle on which they are to be installed:

(1) SAE J914b, July 1978, Table 1 for vehicles 80 inches (2.03m) or more in width, regardless of length; or

(2) SAE J914b, July 1978, Table 2 for vehicles narrower than 80 inches (2.03 m) in width, regardless of length; or

- (3) SAE J914 NOV87, Table 1; or
- (4) SAE J914 JAN95, Table 1; or
- (5) SAE J914 JUL2003, Table 1; or
- (6) SAE J2039 JUN94, Table 1; or
- (7) SAE J2039 MAY2001, Table 1.

(b) Standards for Supplemental Stop or Turn Signal Lamps: Supplemental stop or turn signal lamps shall meet the following standard: SAE J186a, September 1977, Table 1.

**AUTHORITY:**

**Note:** Authority cited: Section 26103, Vehicle Code. Reference: Sections 26103 and 26104, Vehicle Code.

**HISTORY**

1. Amendment filed 4-5-83; effective thirtieth day thereafter (Register 83, No. 15).
2. Repealer and new subsection (a) and amendment of Note filed 10-23-95; operative 11-22-95 (Register 95, No. 43).
3. Amendment filed 1-8-2001; operative 2-7-2001 (Register 2001, No. 2).
4. New subsection (a)(5), subsection renumbering, amendment of newly designated subsection (a)(6) and new subsection (a)(7) filed 8-7-2007; operative 9-6-2007 (Register 2007, No. 32).

**ARTICLE 20.****Traffic Signal Priority Devices****AUTHORITY:**

**Note:** Authority and reference cited: Section 25352, Vehicle Code.

**HISTORY**

1. Repealer of Article 20 (Sections 795-797) filed 12-17-81; effective thirtieth day thereafter (Register 81, No. 51).

**ARTICLE 21.****Warning Lamp Flashers**

- |        |  |
|--------|--|
| § 800. | Scope.                                   |
| § 801. | Performance and Durability Requirements. |
| § 802. | Thermally Operated Flashers.             |
| § 803. | Nonthermally Operated Flashers.          |
| § 804. | Variable Load Flashers.                  |

**§ 800. Scope.**

This article applies to flashers for warning lamps on emergency vehicles and special hazard vehicles.

**AUTHORITY:**

**Note:** Authority cited: Section 26103, Vehicle Code. Reference: Sections 24012, 26103 and 26104, Vehicle Code.

**§ 801. Performance and Durability Requirements.**

Warning lamp flashers shall be designed to conform to SAE J1054, January 1977, except that the sum of the percent current on times of Section 5.3 shall not apply to nonalternating flashers. The tests shall be made at the ampere load specified by the flasher manufacturer for the advertised quantity and type of bulbs and other loads for the device.

**AUTHORITY:**

**Note:** Authority cited: Section 26103, Vehicle Code. Reference: Sections 24012 and 26103, Vehicle Code.

**§ 802. Thermally Operated Flashers.**

Thermally operated flashers shall be tested for compliance with the performance and durability requirements using the procedures in SAE J1104, January 1977, on a sample of the size specified in J1104 obtained at random.

**AUTHORITY:**

**Note:** Authority cited: Section 26103, Vehicle Code. Reference: Sections 24012 and 26103, Vehicle Code.

**§ 803. Nonthermally Operated Flashers.**

Nonthermally operated flashers shall be tested for compliance with the performance and durability requirements using two random flashers for the performance test requirements and two other random flashers for the durability test. Should two failures for performance or two failures for durability tests occur, the flashers shall be considered as not meeting the requirements. Should one failure occur for performance test or one failure occur for durability test, an additional 2 flashers for the performance or for the durability test shall be selected at random and subjected to the corresponding tests. If no further failures of the additional flashers occur, the flasher shall be considered to be in compliance with the requirements.

**AUTHORITY:**

**Note:** Authority cited: Section 26103, Vehicle Code. Reference: Sections 24012 and 26103, Vehicle Code.

**§ 804. Variable Load Flashers.**

Variable load flashers shall comply with starting time, flash rate, and percent of current on time requirements both with the minimum and maximum design loads connected and shall comply with voltage drop and durability requirements with only the maximum design load connected.

**AUTHORITY:**

**Note:** Authority cited: Section 26103, Vehicle Code. Reference: Sections 24012, 26103 and 26104, Vehicle Code.

## ARTICLE 22. Warning Lamps

§ 810.	Scope.
§ 811.	Definitions.
§ 812.	Classification of Warning Lamps.
§ 813.	General Requirements.
§ 814.	Mechanical Test Requirements.
§ 815.	Temperature and Durability Test Requirements.
§ 816.	Color Requirements.
§ 817.	Photometric Test Requirements.
§ 818.	Type of Warning Lamps Used on Emergency Vehicles and Special Hazard Vehicles.

**§ 810. Scope.**

This article applies to warning lamps for emergency vehicles and special hazard vehicles governed by Vehicle Code Sections 25252 through 25282.

**AUTHORITY:**

**Note:** Authority cited: Section 26103, Vehicle Code. Reference: Sections 24012, 26103 and 26104, Vehicle Code.

**HISTORY**

1. Amendment filed 11-25-2002; operative 12-25-2002 (Register 2002, No. 48).

**§ 811. Definitions.**

(a) Warning Lamp -- A "warning lamp" is a lamp designed for use on authorized emergency vehicles and prescribed types of special hazard vehicles to indicate the existence of a traffic hazard or to signal other drivers to stop or yield the right of way.

(b) Warning Lamp Assembly -- A "warning lamp assembly" is a device that consists of a housing with one or more light sources and any lenses, reflectors and any other components or devices necessary to provide the required level of performance.

(c) Warning Lamp Housing -- A "warning lamp housing" is a device that holds a warning lamp unit or the light source(s), lens(es), reflector(s) and other components of a warning lamp assembly.

(d) Warning Lamp Unit -- A "warning lamp unit" is a sealed or semisealed optical unit designed to meet the dimensional specifications of SAE J571d, June 1976, SAE J572a, January 1972, or SAE J760a, December 1974, and which meets the color and photometric requirements.

(e) Flashing Lamp -- A "flashing lamp" is a lamp in which the emitted light in a particular direction alternates between on and off either electrically by controlling the current or mechanically by a revolving, oscillating, or other mechanism, or by other means such that the light output in a given direction is discernibly and regularly interrupted or intermittent at the required periodic rate.

(f) Steady-burning Lamp -- A "steady burning lamp" is a lamp in which the emitted light in any direction is uninterrupted.

(g) Light Source -- A "light source" is an individual incandescent bulb, light emitting diode, or discharge bulb or other device that produces visible light whenever appropriate electrical energy is supplied to it.

(h) Light Pulse -- A single, visually continuous emission of optical energy. High frequency modulation is permitted (reprinted with permission from SAE J595 [January 2005] &copy; 2005 SAE International).

(i) Flash -- A flash is a light pulse, or a train of light pulses, where a dark interval of at least 160ms separates the light pulse or the last pulse of the train of light pulses from the next pulse or the first pulse of the next train of light pulses. To be considered a train of light pulses, each pulse in the train must begin within 100ms after the end of the preceding light pulse. Dark interval luminous intensity shall not exceed two percent of the maximum luminous intensity of a flash (reprinted with permission from SAE J595 [January 2005] • 2005 SAE International).

(j) On-time -- Summation of the light pulse(s) within a flash.

**AUTHORITY:**

**Note:** Authority cited: Section 26103, Vehicle Code. Reference: Section 26103, Vehicle Code.

**HISTORY**

1. Amendment filed 11-25-2002; operative 12-25-2002 (Register 2002, No. 48).  
2. New subsections (h)-(j) filed 10-17-2007; operative 11-16-2007 (Register 2007, No. 42).

**§ 812. Classification of Warning Lamps.**

Five classes of warning lamps are established as follows:



- Class A: High intensity, concentrated-beam lamp
- Class B: Moderate intensity, wide-beam lamp
- Class C: High intensity, wide-beam lamp
- Class D: Motorcycle front warning lamp
- Class E: Revolving, oscillating, or gaseous discharge lamp

lamp

**AUTHORITY:**

**Note:** Authority and reference cited: Section 26103, Vehicle Code.

**§ 813. General Requirements.**

(a) Flash Rate. Flashing warning lamps, other than gaseous discharge lamps, shall operate at a rate of 60 to 120 flashes per minute, with a 40 to 60 percent on-time under all operating conditions. The time between the end of one flash and the beginning of the following flash for a gaseous discharge lamp shall not exceed 0.85 seconds, which corresponds to a minimum of 70 flashes per minute. Flashes having a light output less than the required minimum shall not be counted in reporting flash rate. Light pulses having a light output less than the required minimum shall not be included in the on-time.

(b) Voltage. Warning lamps manufactured for more than one voltage shall comply with all requirements of this title when tested at each voltage. Warning lamps designed to operate on a rated voltage of 12 volts shall be tested at 12.8 volts. Warning lamps designed to operate on a rated voltage of 24 volts shall be tested at 25.6 volts. Warning lamps designed to operate on a rated voltage of other than 12 or 24 volts shall be tested at a voltage equivalent to the voltage provided by the vehicle storage battery charged to 100% capacity with no current drain.

(c) Exterior Lens Surface. The outside surface of the illuminated section of the lens shall be smooth with no ribs, ridges, or indentations other than marks of identification, screw holes, and aiming pads.

(d) Double-Faced Lamps. Steady burning double-faced lamps shall have opaque dividers to minimize exterior light shining through the lamp.

(e) Multiple Light Source Lamps. Lamps with two or more individual light sources shall have all light sources operating together when the lamp is steady burning or flashing.

**AUTHORITY:**

**Note:** Authority cited: Section 26103, Vehicle Code. Reference: Sections 24012 and 26103, Vehicle Code.

**HISTORY**

1. Amendment filed 11-25-2002; operative 12-25-2002 (Register 2002, No. 48).
2. Amendment of subsection (a) filed 10-17-2007; operative 11-16-2007 (Register 2007, No. 42).

**§ 814. Mechanical Test Requirements.**

Warning lamps shall comply with the following mechanical tests described in Article 5 of this subchapter:

- Corrosion
- Dust
- Lens recession
- Vibration
- Warpage (when plastic lenses or housings are used)

None of the above tests are required on all-glass sealed warning lamp units, and the dust and moisture tests are not required on housings for all-glass units.

**AUTHORITY:**

**Note:** Authority cited: Section 26103, Vehicle Code. Reference: Sections 24012 and 26103, Vehicle Code.

**§ 815. Temperature and Durability Test Requirements.**

Flashing warning lamps shall meet the following additional requirements, with all tests conducted on the same sample in the order shown:

(a) High Temperature Test. The sample shall be mounted in normal operating position in a circulating air cabinet for 6 hours at  $49 \pm 3$  degrees C ( $120 \pm 5$  degrees F). The device shall be off during the first hour and shall operate continuously for the next 5 hours with the required voltage applied at the device terminals.

(b) Low Temperature Test. The sample shall be mounted in normal operating position in a circulating air cabinet for 6 hours at  $-32 \pm 3$  degrees C ( $-25 \pm 5$  degrees F). The device shall be turned on at the end of the sixth hour and operated for 3 minutes with the required test voltage applied at the device terminals before measuring the flash rate.

(c) Durability Test. The sample shall be operated continuously for 200 hours at room temperature in cycles consisting of 50 minutes on and 10 minutes off at the required test voltage.

(d) Required Performance. The device shall operate satisfactorily during the tests specified in preceding subdivisions (a), (b), and (c) with no evidence of malfunction. The flash rate shall remain within the required rate for the type of lamp except that the flash rate for lamps used in the low temperature test shall not be less than 50 flashes per minute. The voltage at the terminals of the warning lamp assembly shall be not more than 0.50 volt below the input terminal voltage of 12.8 volts for 12 volt units and not more than 1.0 volt below the required input terminal voltage for lamps intended to operate at 24 volts or more with the device operating. Measurements for the low temperature test shall be made 3 minutes after the beginning of the last hour of operation and at the end of the test. Measurements for the high temperature test shall be made at the end of the test. Measurements for the durability test shall be made at 100 hours and at the end of the test.

**AUTHORITY:**

**Note:** Authority cited: Section 26103, Vehicle Code. Reference: Sections 24012 and 26103, Vehicle Code.

**HISTORY**

1. Amendment of subsections (b) and (d) filed 12-17-81; effective thirtieth day thereafter (Register 81, No. 51).
2. Amendment filed 11-25-2002; operative 12-25-2002 (Register 2002, No. 48).

**§ 816. Color Requirements.**

Warning lamps shall meet the following limits in SAE J578d, September 1978. The color shall be that of the emitted light, not that of the material used for the lens or filter.

- (a) Class A and D Warning Lamps: Red
- (b) Class B, C, and E Warning Lamps: Red, yellow, or blue.

**AUTHORITY:**

**Note:** Authority cited: Section 26103, Vehicle Code. Reference: Sections 24012 and 26103, Vehicle Code.

**§ 817. Photometric Test Requirements.**

The luminous intensity of warning lamps tested as specified in Article 4 of this subchapter, with a reaim tolerance of  $\pm 0.5$  degree vertical and  $\pm 1.0$  degree horizontal allowed at each test point, shall be as follows:

(a) **Steady-burning Warning Lamps.** Steady-burning warning lamps, and flashing warning lamps which alternate between on and off by electrically con-

trolling the current supplied to the lamp, shall meet the requirements in Table I. The photometric output of flashing lamps shall be reported only while the lamp is on. Warning lamp units shall be aimed for this test so the maximum intensity is on the H-V axis. Warning lamp assemblies shall be mounted for this test in accordance with Section 657.

**TABLE I. MINIMUM CANDELA FOR STEADY-BURNING WARNING LAMPS  
AND FLASHING WARNING LAMPS WHICH ALTERNATE BETWEEN ON AND OFF  
BY ELECTRICALLY CONTROLLING THE CURRENT**

Test point Coordinates		Class A Lamps		Class B Lamps		Class C Lamps			Class D Lamps
Vertical	Horizontal	Red	Red	Yellow	Blue	Red	Yellow	Blue	Red
10U	5L	15	20	50	10	10	25	5	5
	V	15	50	125	25	25	65	13	12
	5R	15	20	50	10	10	25	5	5
5U	20L	10	20	50	10	150	375	75	5
	10L	25	50	125	25	300	750	150	12
	5L	50	100	250	50	300	750	150	25
	V	80	150	375	75	300	750	150	40
	5R	50	100	250	50	300	750	150	25
	10R	25	50	125	25	300	750	150	12
	20R	10	20	50	10	150	375	75	5
	30L	-	-	-	-	30	75	15	-
H	20L	30	30	75	15	180	450	90	10
	10L	300	75	190	38	400	1,000	200	15
	5L	500	200	500	100	500	1,250	250	500
	2 1/2L	2,000	-	-	-	-	-	-	1,500
	V	3,000	300	750	150	600	1,500	300	3,000
	2 1/2R	2,000	-	-	-	-	-	-	1,500
	5R	500	200	500	100	500	1,250	250	500
	10R	300	75	190	38	400	1,000	200	15
	20R	30	30	75	15	180	450	90	10
	30R	-	-	-	-	30	75	15	-
5D	30L	-	-	-	-	30	75	15	-
	20L	10	20	50	10	200	500	100	5
	10L	25	50	125	25	300	750	150	12
	5L	50	100	250	50	450	1,100	275	25
	V	80	150	375	75	450	1,100	275	40
	5R	50	100	250	50	450	1,100	275	25
	10R	25	50	125	25	300	750	150	12
	20R	10	20	50	10	200	500	100	5
10D	30R	-	-	-	-	30	75	15	-
	5L	15	20	50	10	40	100	20	5
	V	15	50	125	25	40	100	20	12
	5R	15	20	50	10	40	100	20	5

**NOTE:** Maximum anywhere in yellow shall not exceed 4,000 cd over any area larger than that generated by a radius rotated 0.25 deg.

(b) **Revolving Warning Lamps.** Revolving warning lamps shall meet the requirements in either Table II or Table IV with the required test voltage applied to the input terminals of the complete assembly. A revolving lamp that is designed to project a signal throughout a 360 degree horizontal angle shall be tested with the lamp assembly turned about its vertical axis to the location where the maximum candela reading from the optical unit is reduced the most by any variations in density or shape of the transparent cover or by obstructions in the lamp assembly. A revolving warning lamp that does not project light through a 360 degree horizontal angle shall comply photometrically about those axes straight to the front, sides, and rear of a vehicle to which the lamp is designed to provide a warning signal. As the lamp rotates, the full projected area of the reflector of each light unit shall be visible along the beam axis as the center of the beam moves from 20 degrees left to 20 degrees right of the device axis.

**TABLE II. MINIMUM CANDELA FOR REVOLVING WARNING LAMPS**

Test point coordinates				
Vertical	Horizontal	Red	Yellow	Blue
7.5U	V	50	130	25
5U	V	500	1,250	250
2.5U	V	3,000	7,500	1,500
H	V	5,000	12,500	2,500
2.5D	V	3,000	7,500	1,500
5D	V	500	1,250	250
7.5D	V	50	130	25

(c) **Oscillating Warning Lamps.** Oscillating warning lamps shall meet the requirements in Table III with the required test voltage applied to the input terminals of the complete assembly.

**TABLE III. MINIMUM CANDELA FOR OSCILLATING WARNING LAMPS**

Test point coordinates				
Vertical	Horizontal	Red	Yellow	Blue
7.5U	V	50	130	25
5U	V	500	1,250	250
2.5U	V	3,000	7,500	1,500
	20L	500	1,250	250
	10L1,200	3,000	600	
	5L	3,300	8,250	1,650
H	V	5,000	12,500	2,500
	5R	3,300	8,250	1,650
	10R	1,200	3,000	600
	20R	500	1,250	250
2.5D	V	3,000	7,500	1,500
5D	V	500	1,250	250
7.5D	V	50	130	25

(d) **Gaseous Discharge Warning Lamps.** Gaseous discharge warning lamps shall meet the requirements in Table IV with the required test voltage applied to the input terminals of the complete assembly. Lamps producing 360 degree light output shall be rotated in the photometric test to the point where the lowest H-V reading is recorded, at which location the lamp shall meet the flash energy requirements. The candela-seconds shall be reported as the average for ten consecutive flashes.

(e) **Alternative Technologies.** Nothing in this standard shall be construed to prohibit the use of any appropriate technology for light sources provided the appropriate photometric and other requirements for the type of lamp are met. Steady-burning warning lamps, and flashing lamps which alternate between on and off by interrupting the electrical current to the lamp, shall meet the photometric requirements of Class A, B, C or D as shown in Table I. Warning lamps which approximate or simulate the appearance of revolving warning lamps shall meet the photometric requirements of Table II. Warning lamps which approximate or simulate the appearance of oscillating warning lamps shall meet the photometric requirements of Table III.

(f) **Removal from Service.** Any warning lamp assembly which noticeably fails to function properly shall be removed from service. Warning lamp assemblies which utilize multiple light sources shall be removed from service if any individual light source fails to function properly.

**TABLE IV. MINIMUM CANDELA-SECONDS FOR GASEOUS DISCHARGE WARNING LAMPS**

Test point coordinates				
Vertical	Horizontal	Red	Yellow	Blue
7.5U	V	5	12	3
5U	V	10	25	5
2.5U	V	30	75	15
	20L	5	12	3
	10L	12	30	6
	5L	33	82	17
H	V	50	125	25
	5R	33	82	17
	10R	12	30	6
	20R	5	12	3
2.5D	V	30	75	15
5D	V	10	25	5
7.5D	V	5	12	3

**NOTE:** The L and R test points do not apply to 360-deg lamps.

**AUTHORITY:**

**Note:** Authority cited: Section 26103, Vehicle Code. Reference: Sections 24012 and 26103, Vehicle Code.

**HISTORY**

1. Amendment filed 11-25-2002; operative 12-25-2002 (Register 2002, No. 48).

**§ 818. Type of Warning Lamps Used on Emergency Vehicles and Special Hazard Vehicles.**

Warning lamps on emergency vehicles and special hazard vehicles shall be of the following types:

(a) Required Red Warning Lamps on Authorized Emergency Vehicles. The steady burning red warning lamp required to be visible to the front of an authorized emergency vehicle by Vehicle Code Section 25252 shall be a Class A, B or C warning lamp. Motorcycles may instead be equipped with two Class D warning lamps in the front, one of which may flash.

(b) Permitted Additional Red Warning Lamps on Authorized Emergency Vehicles. The additional steady burning or flashing red warning lamp permitted by Vehicle Code Section 25252 shall be a Class A, B, C, or E warning lamp.

(c) Permitted Yellow Warning Lamps on Authorized Emergency Vehicles. The additional flashing yellow warning lamp permitted on authorized emergency vehicles by Vehicle Code Section 25259 shall be a Class B, C, or E warning lamp. Two yellow motorcycle turn signal lamps may be used as warning lamps on the rear of motorcycles.

(d) Permitted Blue Warning Lamps on Police Vehicles. The additional flashing or steady burning blue warning lamp permitted by Vehicle Code Section 25258(b) shall be Class B, C, or E.

(e) Required Yellow Warning Lamps on Tow Cars. The flashing yellow warning lamp required on tow cars by Vehicle Code Section 25253 shall be a Class B, C, or E warning lamp. The flashing yellow warning lamp permitted to be displayed to the rear of a tow car while towing a vehicle and moving at a speed slower than the normal flow of traffic may be a 360-degree revolving or gaseous discharge lamp. In such case, the front and side areas of the lens or transparent cover that extends back to 45 degrees to each side of the straight-to-the-rear axis of the lamp shall be covered with opaque material reaching to the top of the lighted area. A revolving lamp may instead be equipped with a device that turns each light source off during the forward three-fourths of its rotation.

(f) Permitted Yellow Warning Lamps on Special Hazard Vehicles. The flashing yellow warning lamps permitted on special hazard vehicles by Article 7 of Division 12 of the Vehicle Code beginning with Section 25252, shall be a Class B, C, or E warning lamp, depending on whether the lamp is permitted to be displayed only to the front and rear or to the front, sides, and rear.

(g) Warning Lamps for Undercover Cars. The required steady-burning forward-facing warning lamps on authorized emergency vehicles with special plates permitted by Vehicle Code Section 5001 shall be a class A, B, or C. This warning lamp may also be a fixed or hand-held red spotlight with a filament of at least 30 watts, and producing at least 3,000 candela in red at the brightest point in the beam. Such a lamp need not meet any of the other requirements of this article except for color. Additional steady-burning or flashing warning lamps shall be class A, B, C, or E. These warning lamps may be displayed through transparent or translucent material provided the light, of proper color, is plainly visible and understandable in bright sunlight and during darkness,

under normal atmospheric conditions, to a distance of 800 feet from the vehicle. These lights shall not transfigure, disrupt or mask any other required lighting device.

**AUTHORITY:**

**Note:** Authority cited: Section 26103, Vehicle Code. Reference: Sections 24012 and 26103, Vehicle Code.

**HISTORY:**

1. Amendment of subsections (e) and (g) filed 11-25-2002; operative 12-25-2002 (Register 2002, No. 48).

**ARTICLE 23.  
School Bus Strobe Lamps**

§ 819. Scope.  
§ 820. School Bus Strobe Lamp.

**§ 819. Scope.**

This article applies to white strobe lamps permitted on school buses by Vehicle Code section 25257.7.

**AUTHORITY:**

**Note:** Authority cited: Sections 25257.7 and 26103, Vehicle Code. Reference: Sections 24012, 25257.7 and 26103, Vehicle Code.

**HISTORY:**

1. New section filed 3-8-91; operative 4-7-91 (Register 91, No. 15).  
2. Editorial correction of NOTE (Register 91, No. 31).

**§ 820. School Bus Strobe Lamp.**

School bus strobe lamps shall meet the requirements in SAE J1318, April 1986 for a 360 degree white gaseous discharge warning lamp with minimum photometric values equal to the requirements of a SAE class 2 lamp.

**AUTHORITY:**

**Note:** Authority cited: Sections 25257.7, and 26103, Vehicle Code. Reference: Sections 24012, 25257.7 and 26103, Vehicle Code.

**HISTORY:**

1. New section filed 3-8-91; operative 4-7-91 (Register 91, No. 15).

**CHAPTER 4.  
Special Equipment**

**ARTICLE 12.  
Brake Equipment**

§ 1060. Scope of Regulations.  
§ 1061. Air Governor Adjustment.  
§ 1062. Safety Valve Adjustment.  
§ 1063. Load-Controlled Air Pressure Reducing System.  
§ 1064. Wheel-Controlled Air Pressure Reducing System.  
§ 1065. Pressure Controlled Reducing System.  
§ 1066. General Requirements for Load, Wheel, and Pressure Controlled Air Pressure Reducing Systems.

**§ 1060. Scope of Regulations.**

**AUTHORITY:**

**Note:** Authority cited: Section 2402, Vehicle Code. Reference: Sections 26502, 26503 and 26504, Vehicle Code.

**HISTORY:**

1. New Article 12 ( §§1060 through 1065) filed 7-15-69; designated effective 8-15-69 (Register 69, No. 29).  
2. Repealer of Section 1060 filed 5-19-83 by OAL pursuant to Government Code Section 11349.7(j); effective thirtieth day thereafter (Register 83, No. 21).

**§ 1061. Air Governor Adjustment.**

Air compressor governors shall be adjusted to operate as follows:

(a) **Cut-in Pressure.** Cut-in pressure shall not be less than 85 psi for full air brake systems on any motor vehicle and not less than 65 psi for air-assisted hydraulic brakes on motor vehicles with a gross vehicle weight rating of not more than 25,000 pounds.

(b) **Cutout Pressure.** Cutout pressure shall not be more than 130 pounds per square inch unless the maximum air delivered to the brake system reservoir is regulated to provide between 100 and 130 pounds per square inch, in which case the cutout pressure shall be adjusted to not more than 150 pounds per square inch.

**AUTHORITY:**

**Note:** Authority and reference cited: Section 26504, Vehicle Code.

**HISTORY**

1. Amendment filed 1-30-80; designated effective 3-1-80 (Register 80, No. 5).

**§ 1062. Safety Valve Adjustment.**

Airbrake safety valves shall be adjusted to operate as follows:

(a) **Normal Discharge Pressure.** Safety valves in airbrake systems with an air governor cutout pressure of not more than 130 pounds per square inch shall open and shall relieve the pressure so that it will not exceed 150 pounds per square inch under any condition.

(b) **Above Normal Discharge Pressure.** Safety valves in airbrake systems with an air governor cutout pressure of 130 to 150 pounds per square inch, as provided in Section 1061(b) of this article, shall open and shall relieve the pressure so that it will not exceed 170 pounds per square inch under any condition. In no case shall the safety valve be set to open at more than the maximum allowable working pressure of the airbrake reservoirs.

**AUTHORITY:**

**Note:** Authority and reference cited: Section 26503, Vehicle Code.

**HISTORY**

1. Editorial correction adding NOTE filed 4-28-83 (Register 83, No. 18).

**§ 1063. Load-Controlled Air Pressure Reducing System.**

(a) Systems that automatically reduce air pressure at brake actuators during brake application in proportion to the axle load shall operate as follows:

(1) When the single or tandem-axle load on the roadway is 85 percent or more of the maximum legal load or rated gross weight of the axle, whichever is lower, the device or system shall not reduce the full service brake air pressure at the brake chambers to less than that required by Vehicle Code Section 26502 unless the vehicle meets the requirements of Federal Motor Vehicle Safety Standard 121 (49 CFR 571.121) in effect at time of manufacture.

(2) The system shall incorporate a feature to override the automatic control, at the driver's discretion, to allow at least 90 percent of the air supply pressure at the foot valve to be applied to the brake actuators upon full brake application, except on axles designed to carry not more than 50 percent of the maximum legal load or

gross weight rating of the axle and used in tandem with a maximum legal load carrying axle on the same vehicle.

(b) Systems that automatically reduce the application air pressure at brake actuators on truck tractors depending upon whether the semitrailer

is connected or disconnected shall operate so the truck tractor meets the brake requirements of Federal Motor Vehicle Safety Standard 121.

**AUTHORITY:**

**Note:** Authority and reference cited: Section 26502, Vehicle Code.

**HISTORY**

1. Editorial correction adding NOTE filed 4-28-83 (Register 83, No. 18).  
2. Amendment filed 8-31-83; effective thirtieth day thereafter (Register 83, No. 36).  
3. Amendment of subsection (a)(1) filed 3-10-86; effective thirtieth day thereafter (Register 86, No. 11).

**§ 1064. Wheel-Controlled Air Pressure Reducing System.**

Brake systems that automatically reduce air pressure at the brake actuator to maintain wheel rotation during brake application shall allow at least 90 percent of the air supply pressure at the foot valve to be applied to the brake actuator upon full brake application when the wheel rotates at a rate corresponding to the speed of the vehicle.

**AUTHORITY:**

**Note:** Authority and reference cited: Section 26502, Vehicle Code.

**HISTORY**

1. Editorial correction adding NOTE filed 4-28-83 (Register 83, No. 18).  
2. Amendment filed 8-31-83; effective thirtieth day thereafter (Register 83, No. 36).

**§ 1065. Pressure Controlled Reducing System.**

Brake systems that automatically apply a lower air pressure to certain axles in comparison to other axles on the vehicle or combination of vehicles to obtain balanced braking between axles shall apply equal pressure to all brake actuators when the manual brake control application pressure is 60 psi or more.

**AUTHORITY:**

**Note:** Authority and reference cited: Section 26502, Vehicle Code.

**HISTORY**

1. Renumbering and amendment of former Section 1065 to Section 1066 and new Section 1065 filed 8-31-83; effective thirtieth day thereafter (Register 83, No. 36).

**§ 1066. General Requirements for Load, Wheel, and Pressure Controlled Air Pressure Reducing Systems.**

All devices or systems for automatically reducing the air pressure delivered to brake actuators on any vehicle or combination of vehicles shall meet the following general requirements:

(a) **Stopping Distance.** The device or system shall not increase the stopping distance under any condition of load beyond that attained by the same type of vehicle or combination of vehicles when not equipped with the device or system.

(b) **Brake-Release Time.** The device or system shall not increase the brake-release time over that which would have been attained if the device had not been installed in the system.

(c) Fail-Safe Operation. Any single failure in any part of the device or its control system shall not increase the stopping distance beyond the statutory limits.

(d) Deceleration. The device or system shall permit deceleration at maximum braking capability without causing the vehicle to swerve from a 3.66 m (12 ft) wide lane that is dry, smooth, hard-surfaced, free from loose material, and has a grade not exceeding plus or minus 1 percent.

**AUTHORITY:**

**Note:** Authority and reference cited: Section 26502, Vehicle Code.

**HISTORY**

1. Editorial correction adding NOTE filed 4-28-83 (Register 83, No. 18).
2. Renumbering and amendment of former Section 1065 to Section 1066 filed 8-31-83; effective thirtieth day thereafter (Register 83, No. 36).

## ARTICLE 14. Tires and Rims

§ 1080.	Scope.
§ 1081.	Definitions.
§ 1082.	New Tire Requirements.
§ 1083.	New Tire Marking.
§ 1084.	Identification Markings on Radial Tire Inner Tubes.
§ 1085.	Tire and Rim Size and Capacity.
§ 1086.	Regrooved Tire Design and Construction.
§ 1087.	Tire Condition and Use.

**§ 1080. Scope.**

This article shall apply to all tires and rims sold for use, or used on vehicles.

**AUTHORITY:**

**Note:** Authority and reference cited: Sections 27455, 27465, 27500, 34501, 34501.5, and 34508, Vehicle Code.

**HISTORY**

1. New section filed 6-30-99; operative 7-30-99 (Register 99, No. 27). For prior history, see Register 84, No. 35.

**§ 1081. Definitions.**

(a) "CRSC" is the California Retreading Standards Committee.

(b) "FMVSS" is a Federal Motor Vehicle Safety Standard. These standards are located in Title 49, Code of Federal Regulations, Part 571. (e.g., FMVSS No. 109 is in Section 571.109, and FMVSS No. 119 is in Section 571.119.)

(c) "Groove" is the space between adjacent tread ribs, lugs, or other tread configurations that are separated by at least 5/64 inch (2 mm).

(d) "Major groove" is any tread circumferential depression or circumferential series of depressions that has tread wear indicators or had the greatest equal depth when the tire was new.

(e) "Multipurpose passenger vehicle" is a motor vehicle designed for carrying not more than 10 persons, including the driver, and constructed either on a truck chassis or with special features for occasional off-highway operation.

(f) "Passenger car" is a motor vehicle designed for carrying not more than 10 persons, including the driver. The term excludes multipurpose passenger vehicles and all housecars, motortrucks, truck tractors, motorcycles, and motor-driven cycles, as defined in the Vehicle Code.

(g) "Regroovable tire" is a tire manufactured with sufficient material for renewal of the original tread pat-

tern or generation of a new tread pattern without exposing the cord.

(h) "Regrooved tire" is a tire on which the tread or retread pattern has been renewed or a new tread has been produced by cutting new grooves.

(i) "Tread pattern" is the nonskid design on the tread of the tire.

(j) "Tread wear indicator" is the raised section in a groove that enables a person inspecting a tire to determine visually whether the tire has worn to a tread depth of 2/32 inch (1.6 mm), except 1/32 inch (0.8 mm) in the case of motorcycle tires.

**AUTHORITY:**

**Note:** Authority and reference cited: Section 27500, Vehicle Code.

**HISTORY**

1. Amendment filed 12-20-76; designated effective 2-1-77 (Register 76, No. 52).
2. Amendment filed 1-18-82; effective thirtieth day thereafter (Register 82, No. 4).
3. Amendment of subsections (b), (c) and (j) filed 6-30-99; operative 7-30-99 (Register 99, No. 27).

**§ 1082. New Tire Requirements.**

Tires sold for use or used on vehicles shall meet the following requirements:

(a) Tires for passenger cars. Tires for passenger cars shall meet the requirements of FMVSS 109.

(b) Tires for vehicles other than passenger cars shall meet the requirements of FMVSS 119.

(c) regroovable Tires for Commercial Vehicles. regroovable commercial vehicle tires shall meet the requirements of Title 49, Code of Federal Regulations, Part 569, and be marked at the time of manufacture with the word "regroovable" on both sidewalls.

**AUTHORITY:**

**Note:** Authority and reference cited: Section 27500, Vehicle Code.

**HISTORY**

1. Amendment of subsections (a) and (b) filed 12-20-76; designated effective 2-1-77 (Register 76, No. 52).
2. Repealer of Section 1082 and renumbering and amendment of Section 1083 to Section 1082 filed 1-18-82; effective thirtieth day thereafter (Register 82, No. 4).

**§ 1083. New Tire Marking.**

New tires shall have all of the markings required by FMVSS Nos. 109 and 119, and Part 574, Title 49, Code of Federal Regulations. Markings such as "blem" or "no adjust" added after manufacture shall be placed near the serial number without damaging or exposing the cord or defacing the serial number.

**AUTHORITY:**

**Note:** Authority and reference cited: Section 27500, Vehicle Code.

**HISTORY**

1. Renumbering of Section 1084 to Section 1083 filed 1-18-82; effective thirtieth day thereafter (Register 82, No. 4).

**§ 1084. Identification Markings on Radial Tire Inner Tubes.**

In lieu of the red valve stem as provided in Vehicle Code Section 27455, the valve stem of a radial tire inner tube may have the word "RADIAL" molded or stamped in letters at least 3.0 mm (0.12 in.) in height on the valve stem or on a sleeve or ferrule permanently affixed to the

valve stem. The marking shall be visible when the tube and tire are mounted on a rim.

**AUTHORITY:**

**Note:** Authority and reference cited: Section 27455, Vehicle Code.

**HISTORY**

1. Renumbering and amendment of Section 1085 to Section 1084 filed 1-18-82; effective thirtieth day thereafter (Register 82, No. 4).

**§ 1085. Tire and Rim Size and Capacity.**

(a) **Passenger Cars.** Tires manufactured after January 1, 1968, and used on passenger cars manufactured after 1948 shall be of the sizes listed in one of the publications referenced in FMVSS No. 109 or in a publication of the tire manufacturer which is provided to the public.

(b) **Matching of Passenger Car Tires and Rims.** Tires for all passenger cars manufactured after 1948, of sizes listed in one of the publications referenced in FMVSS No. 109 or in a publication of the tire manufacturer which is provided to the public, shall be installed and used only on the appropriate rims specified for the particular tire size by the tire manufacturer or by organizations listed in FMVSS No. 109.

(c) **Matching of Tires and Rims on Other Vehicles.** Tires installed on vehicles other than passenger cars shall be mounted only on rims specified for the particular tire size by the tire manufacturer or by organizations listed in FMVSS No. 119.

(d) **Tire Load Limits.** Loads on tires shall comply with the following requirements:

(1) Passenger car tires used on passenger cars or station wagons shall not be loaded above the maximum load rating marked on the tire, or, if unmarked, the maximum load rating specified in one of the publications referenced in FMVSS No. 109 or in a publication furnished to the public by the tire manufacturer. Passenger car tires used on other vehicles shall not be loaded beyond the foregoing maximum divided by 1.1.

(2) Tires for trucks, buses, trailers, motorcycles, or any vehicles other than passenger cars shall not be loaded above the maximum load rating marked on the tire, or if unmarked, the maximum load rating specified by the organizations listed in FMVSS No. 119 or the tire manufacturer's recommendations for the tire size, ply rating, and service speed.

(3) Tires covered by FMVSS No. 119 may carry increased loads at speeds of 54 mph (87 km/h) or less in accordance with tables published by the organizations listed in that standard, provided that either:

(A) The speed of the vehicle is mechanically restricted to no more than the rated speed for the load carried by the tire, or

(B) The vehicle, or combination of vehicles carries, on the rear of the last vehicle, a sign showing the maximum speed for the tire load (Figure 1 Speed Restriction Sign). The sign shall be located so that a following driver can read it with ease.

(C) The background of the Speed Restriction Sign shall be yellow, extending at least 1 inch (26 mm) beyond the words. The letter on the sign shall be at least 4 inches (100 mm) high, with a stroke 1/2 inch (13 mm) wide. All words may be on one line.



Figure 1. Speed Restriction Sign

(4) **Tire loading restrictions for manufactured homes.** Tires used for the transportation of manufactured homes (i.e., tires marked or labeled 7-14.5MH or 8-14.5MH) may be loaded up to 18 percent over the load rating marked on the sidewall of the tire or, in the absence of such a marking, 18 percent over the load rating specified in any of the publications of any of the organizations listed in FMVSS No. 119, pursuant to 49 CFR 393.75(g). Manufactured homes which are labeled on or after November 16, 1998, shall comply with 24 CFR 3282.7(r), April 1, 1998. Manufactured homes transported on tires overloaded by 9 percent or more must not be operated at speeds exceeding 50 mph (80 km/h).

(5) Vehicles that do not have a mechanically restricted speed or the reduced speed sign, or do have the sign but do not comply with the reduced speed shown on the sign, shall not carry increased tire loads.

(e) **LT Tires.** Tires identified with the letters "LT" in the size markings (such as 7.00-15LT or LT 235/75R15) shall be used only on vehicles other than passenger cars and motorcycles.

(f) **MH Tires.** Tires identified with the letters "MH" after the size (such as 8-14.5MH) are designed for mobilehomes and shall not be used on other vehicles unless marked with the letters "DOT" in accordance with FMVSS 119.

(g) **ML Tires.** Tires identified with the letters "ML" after the size (such as 10.00-22ML) are designed for intermittent on/off road service such as mining and logging operations and shall not be used on vehicles traveling more than 55 miles (89 km) in any 1 1/2-hr period or at a speed of more than 55 mph (89 km/h). Certain sizes of ML tires marked with a 50-mph speed limit shall not exceed 50 mph (80 km/h) or 50 miles (80 km) in any 1 1/2-hour period.

(h) **MS Tires.** Tires permanently marked on one sidewall with the words "MUD AND SNOW" or any contraction using the letters "M" and "S" and designated by the tire manufacturer as being designed to provide additional traction in mud and snow in accordance with the definition of the Rubber Manufacturers Association may be used in lieu of tire chains where chain control signs permit snow tires.

(i) **NHS Tires.** Tires identified with the letters "NHS" after the size (such as 7.00-15NHS) are not designed for highway service and shall be used only on vehicles such as short haul mining, earthmoving and logging service at speeds not exceeding 40 mph (64 km/h) and shovels, front end loaders, dozers, and fork lifts at speeds not exceeding 10 mph (16 km/h). Tires identified as "NHS" may be used on cotton trailers (defined as implements of husbandry in Vehicle Code Section 36005) when such trailers are operated at not more than the



speed limit labeled on the tire sidewall or, if not labeled, not more than 40 mph (64 km/h).

(j) **SL Tires.** Tires identified with the letters "SL" after the size (such as 9.00-16SL) are designed for limited service and shall be used only on agricultural and industrial equipment operated at not more than 20 mph (32 km/h).

(k) **ST and Other Trailer Tires.** Tires identified with the letters "ST" (such as 7.00-13ST) or with the words "TRAILER" or "TRAILER SERVICE" after the size shall not be used on motor vehicles.

(l) **T Tires.** Tires identified with the letter "T" after the size (such as 3.75-19T) shall be used only on motorcycles or sidecars.

(m) **Tires for Buses.** Tires marked as follows are designed for buses and shall be used only as stated: "INTER-CITY" and "THRUWAY" may be used in any service at normal highway speeds. "INTRA-CITY" may be used only in slow speed start-stop service with maximum speed not exceeding 35 mph (56 km/h). "CITY-SUBURBAN" may be used only at speeds not exceeding 55 mph (89 km/h) for not more than one hour of continuous operation.

**AUTHORITY:**

**Note:** Authority and reference cited: Sections 27500, 31401, 34501, 34501.5, and 34508, Vehicle Code.

**HISTORY**

1. Amendment of subsection (e) filed 8-9-78; designated effective 9-15-78 (Register 78, No. 32). For former history, see Registers 76, No. 10; 76, No. 21; 76, No. 52; 77, No. 37; and 77, No. 52.
2. Renumbering and amendment of section 1086 to section 1085 filed 1-18-82; effective thirtieth day thereafter (Register 82, No. 4).
3. Amendment of subsections (e)(1) and (2) filed 10-19-83; effective thirtieth day thereafter (Register 83, No. 43).
4. Amendment filed 8-31-84; effective thirtieth day thereafter (Register 84, No. 35).
5. Change without regulatory effect amending subsection (d)(4) filed 4-12-91 pursuant to section 100, title 1, California Code of Regulations (Register 91, No. 18).
6. Amendment filed 6-30-99; operative 7-30-99 (Register 99, No. 27).

**§ 1086. Regrooved Tire Design and Construction.**

Regrooved tires shall be designed and constructed as follows:

(a) **Design.** No tire shall be regrooved unless it is designed to permit a renewed or newly generated tread pattern and is marked "regroovable" at the time of manufacture or it has a retread designed to be regrooved and is marked "regroovable" when retreaded.

(b) **Construction.** Regrooved tires shall be constructed with at least a 3/32-in. (2.4-mm) layer of tread material between the cord structure and the new grooves, which shall be not less than 3/16 in. (4.8 mm) nor more than 5/16 in. (7.9 mm) wide. Regrooved tires shall not show evidence of ply, tread, or sidewall separation; sidewall wear that exposes the fabric; or tread or groove cracks extending to the fabric.

**AUTHORITY:**

**Note:** Authority cited: Section 27500, Vehicle Code. Reference: Section 27461, Vehicle Code.

**HISTORY**

1. Renumbering of Section 1087 to Section 1086 filed 1-18-82; effective thirtieth day thereafter (Register 82, No. 4).

**§ 1087. Tire Condition and Use.**

(a) **Defects.** Tires shall not be used with boot or blow-out patches or with any of the following defects:

- (1) Unrepaired fabric breaks
- (2) Exposed or damaged cord
- (3) Bumps, bulges, or knots due to internal separation or damage
- (4) Cuts that measure more than 1 in. (25 mm) and expose body cord
- (5) Cracks in valve stem rubber

(b) **Regrooved Tires.** Regrooved tires shall not be used on school buses or any vehicle other than a commercial vehicle. Such tires used on commercial vehicles shall be of a type manufactured and designed for regrooving. Regrooved tires, regardless of size, shall not be used on the front wheels of buses, and regrooved tires which have a load carrying capacity equal to or greater than that of 8.25-20 8 ply-rating tires shall not be used on the front wheels of any other motor vehicle listed in Vehicle Code Section 34500.

(c) **Recapped Tires.** Tires recapped or retreaded for highway use shall have a tread pattern that complies with Section 27465 of the Vehicle Code and with this section. Recapped or retreaded tires shall not be used on front wheels of a bus or farm labor vehicle. Such tires shall not be used on the front wheels of truck tractors or motortrucks listed in Vehicle Code Section 34500 unless the tires are in compliance with the following requirements:

(1) Tires shall have been retreaded or recapped not more than 2 times and shall contain no casing repair other than that required by a nail puncture.

(2) Tires shall conform to either the labeling and other requirements of the 1972 CRSC Retreading Specifications and Standards or to the Industry Standards For Tire Retreading & Repairing revised September 1, 1995. Tires retreaded on or after November 1, 1997, shall conform to the Industry Standards For Tire Retreading & Repairing revised September 1, 1995.

(3) A new-tire manufacturer who is assigned an identification number by the U.S. Department of Transportation (DOT) may certify adherence to standards equal to or better than CRSC standards (only until November 1, 1997), or the Industry Standards For Retreading & Repairing revised September 1, 1995 for retreaded tires produced in his/her company-owned and -operated retreading facilities. Such certification shall comply with marking or labeling requirements of CRSC (only until November 1, 1997), or the Industry Standards For Tire Retreading & Repairing revised September 1, 1995, except that the certification mark branded into the tire may be of original design. A certification mark of original design shall show the name or trademark and assigned DOT registration number of the manufacturer and designate which of his/her retreading facilities produced the tire.

(4) **Successive Retreads.** When a retreaded tire bearing the markings specified in preceding subsections is retreaded a second time, the prescribed label shall be cancelled by a diagonal line or other distinctive mark through the label.

(d) **Tires on Dual Wheels.** The outside diameters of tires used on dual wheels shall be so matched that on

a level roadway each tire will contact the surface at all times.

**AUTHORITY:**

**Note:** Authority cited: Sections 27500, 31401, 34501, 34501.5 and 34508, Vehicle Code. Reference: Sections 27500, 27501, 31401, 34501, 34501.5 and 34508, Vehicle Code.

**HISTORY**

1. Amendment of subsection (a)(1) filed 12-20-76; designated effective 2-1-77 (Register 76, No. 52).
2. Amendment of subsection (c) filed 9-7-77 as an emergency; effective upon filing (Register 77, No. 37).
3. Certificate of Compliance filed 12-23-77 (Register 77, No. 52).
4. Renumbering of section 1088 to section 1087 filed 1-18-82; effective thirtieth day thereafter (Register 82, No. 4)
5. Amendment filed 6-28-82; effective thirtieth day thereafter (Register 82, No. 27).
6. Amendment filed 10-19-83; effective thirtieth day thereafter (Register 83, No. 43).
7. Amendment filed 10-30-86; effective thirtieth day thereafter (Register 86, No. 44).
8. Amendment of subsection (b) filed 9-21-94; operative 9-21-94 pursuant to Government Code section 11346.2(d) (Register 94, No. 38).
9. Amendment of subsections (c)(2) and (c)(3) filed 7-10-97; operative 8-9-97 (Register 97, No. 28).

# TITLE 16

## PROFESSIONAL AND VOCATIONAL REGULATIONS

### DIVISION 33.

#### Bureau of Automotive Repair

### CHAPTER 1.

#### Automotive Repair Dealers and Official Stations and Adjusters

### ARTICLE 1.

#### General Provisions

- § 3300. Location of Office.
- § 3301. Continuation of Existing Regulations. [Repealed]
- § 3302. Tenses, Gender and Number. [Repealed]
- § 3303. Definitions.
- § 3303.1. Public Access to License, Administrative Action, and Complaint Information.
- § 3303.2. Review of Applications for Licensure, Registration and Certification; Processing Time.
- § 3303.3. Current Address Required.
- § 3303.4. Nondiscrimination Clause.
- § 3303.4.1. Applicant Compliance with PRWORA.
- § 3303.4.2. Requirements for Licensure for Certain Aliens.
- § 3303.4.3. PRWORA Verification.
- § 3303.4.4. No Refund of Application Fee.

#### § 3300. Location of Office.

#### AUTHORITY:

**Note:** Authority cited: Sections 9882, 9887.1 and 9888.2, Business and Professions Code. Reference: Sections 9882 and 9887.1, Business and Professions Code.

#### HISTORY

1. New chapter 33 (sections 3300-3303, 3304-3315, 3316, 3320, 3321, 3325-3327) filed 3-6-72 as an emergency; effective upon filing (Register 72, No. 11).
2. Certificate of Compliance filed 5-11-72 (Register 72, No. 20).
3. Amendment filed 7-25-75; effective thirtieth day thereafter (Register 75, No. 30).
4. Redesignation of sections 3300-3395 as subchapter 1 filed 3-15-79 as an emergency; effective upon filing (Register 79, No. 11).
5. Amendment of NOTE filed 2-22-83; effective thirtieth day thereafter (Register 83, No. 9).
6. Amendment filed 3-28-86; effective thirtieth day thereafter (Register 86, No. 13).
7. Amendment of subchapter 1 heading filed 9-26-90; operative 10-26-90 (Register 90, No. 44).
8. Editorial correction of printing error removing duplicate text (Register 91, No. 32).
9. Change without regulatory effect repealing section filed 5-8-2008 pursuant to section 100, title 1, California Code of Regulations (Register 2008, No. 19).

#### § 3301. Continuation of Existing Regulations. [Repealed]

#### AUTHORITY:

**Note:** Authority Cited: Section 9882, Business and Professions Code.

#### HISTORY

1. Repealer filed 2-22-83; effective thirtieth day thereafter (Register 83, No. 9).

#### § 3302. Tenses, Gender and Number. [Repealed]

#### AUTHORITY:

**Note:** Authority cited: Section 9882, Business and Professions Code.

#### HISTORY

1. Repealer filed 2-22-83; effective thirtieth day thereafter (Register 83, No. 9).

#### § 3303. Definitions.

In this chapter, unless the context otherwise requires:

(a) "Code" means the Business and Professions Code.

(b) "Department" means the Department of Consumer Affairs.

(c) "Act" means the Automotive Repair Act as contained in Chapter 20.3, Division 3 of the Business and Professions Code.

(d) "Passenger vehicle" means a motor vehicle used for private transportation or recreational purposes, including recreational vehicles and excluding commercial vehicles.

(e) "Commercial vehicle" means a vehicle designed, used or maintained primarily for the transportation of persons or property for hire, compensation or profit.

(f) "Recreational vehicle" means a motor vehicle designed or altered for recreational purposes or for human habitation and includes a motor vehicle used for transporting camper units.

(g) "Compensation" means any form of remuneration received for repairing or diagnosing malfunctions of motor vehicles. Where repair or diagnostic work is performed pursuant to a warranty, compensation is presumed to have been paid, whether the warranty has been obtained in connection with the purchase of a motor vehicle or otherwise.

(h) "Repair of motor vehicles" as used in subdivision (e) of Section 9880.1 of the Act shall not include the repair of that portion of a recreational vehicle which is intended for human habitation and which is unrelated to the operation of the vehicle, or a transmission fluid change.

(i) "Transmission fluid change" means changing the transmission fluid without removing the transmission pan or changing the transmission filter.

(j) "Authorization" means consent. Authorization shall consist of the customer's signature on the work order, taken before repair work begins. Authorization shall be valid without the customer's signature only when oral or electronic authorization is documented in accordance with applicable sections of these regulations.

(k) "Building" means a permanent structure with walls, a floor, and a roof.

(l) "Auto body repair shop" means an automotive repair dealer who performs repairs or reconstruction of automobile or truck bodies, structures, or frames. Auto body repair shop does not include an automotive repair dealer also licensed by the department of Motor Vehicles as a motor vehicle dealer who engages in either the activity of up-fitting or down-fitting its vehicle inventory, or performs those repairs that may be performed without utilizing the tools or equipment required by Section 3351.5.

(m) "Section" or "Sectioning" means the replacement of less than a whole part or component by splicing the part or component at non-factory seams.

(n) "Corrosion protection" means a coating applied to the vehicle to create a corrosion resistant barrier that protects the structure or component from the elements to which it is exposed.

(o) "Structure" means those components or parts that are designed to support weight, absorb collision energy, and absorb road shock.

(p) "Crash part" means a replacement for any of the non-mechanical sheet metal or plastic parts which generally constitute the exterior of a motor vehicle, including inner and outer panels.

(q) "Original Equipment Manufacturer crash part" or "OEM crash part" means a crash part made for or by the original vehicle manufacturer that manufactured, fabricated or supplied a vehicle or a component part.

(r) "Non-Original Equipment Manufacturer aftermarket crash part" or "non-OEM aftermarket crash part" means aftermarket crash parts not made for or by the manufacturer of the motor vehicle.

**AUTHORITY:**

**Note:** Authority cited: Sections 9882, 9884.9, 9884.19 and 9887.1, Business and Professions Code. Reference: Sections 9880.1(a), (e) and (f), 9882, 9884.7(a)(2), 9884.9, 9889.50, 9889.51 and 9889.52, Business and Professions Code.

**HISTORY:**

1. New subsections (f) through (o) filed 12-29-72; effective thirtieth day thereafter (Register 72, No. 53).
2. Amendment of subsection (o) and new subsection (p) filed 6-9-78; effective thirtieth day thereafter (Register 78, No. 23).
3. Amendment filed 2-22-83; effective thirtieth day thereafter (Register 83, No. 9).
4. Amendment of subsection (e) filed 8-18-92; operative 9-17-92 (Register 92, No. 37).
5. Amendment of subsection (h), new subsection (i) and subsection relettering filed 3-7-97; operative 4-6-97 (Register 97, No. 10).
6. New subsections (m)-(s) and amendment of Note filed 10-20-97; operative 11-19-97 (Register 97, No. 43).
7. Amendment of subsection (k) and amendment of Note filed 5-2-2002; operative 6-1-2002 (Register 2002, No. 18).
8. Change without regulatory effect repealing subsection (j), relettering subsections and amending newly designated subsections (m) and (o)-(r) filed 6-5-2006 pursuant to section 100, title 1, California Code of Regulations (Register 2006, No. 23).

**§ 3303.1. Public Access to License, Administrative Action, and Complaint Information.**

It is the policy of the bureau that information regarding licenses, administrative actions and complaints shall be made available, pursuant to the California Public Records Act (Chapter 3.5 of Division 7 of Title 1 of the Government Code, commencing with Section 6250) to any person who requests that information. The following provisions implement departmental policy within the bureau by establishing an information system designed to provide individual members of the public with information about bureau registrants and licensees. Information subject to public disclosure shall be provided to members of the public, upon request, by telephone, in person, or in writing (including fax or e-mail). The information, when feasible and to the extent required or permitted by law, shall be made available by the bureau in writing. Requests for information shall be responded to within ten (10) days.

(a) The bureau will disclose the following information, as applicable, regarding past and current registrants or licensees:

(1) The name of the registrant or licensee, as it appears in the bureau's records, including all fictitious or business names shown therein.

(2) The registration or license number.

(3) The address of record.

(4) The date of original registration or licensure.

(5) The current status of the registration or license.

(6) The date the registration or license will expire, or has expired, and, if applicable, the date the registration or license was suspended, revoked, cancelled or otherwise terminated.

(b) The bureau will disclose the following information regarding administrative action taken by the bureau against registrants or licensees:

(1) The total number of administrative actions taken.

(2) A brief summary of the violations alleged in the administrative actions.

(3) The current status of pending administrative actions, if any. Disclosure of pending actions shall contain a disclaimer stating that the pending administrative action(s) against the registrant(s) or licensee(s) is/are alleged and no final legal determination has yet been made. Further disclaimers or cautionary statements regarding pending actions may also be made.

(4) The final disposition, if any, of the administrative actions, including any discipline or penalty imposed. Citations that have been satisfactorily resolved shall be disclosed as such.

(5) Any additional information that is statutorily mandated to be disclosed.

(c)(1) The bureau will disclose complaint information when the Chief, or the Chief's designee, has determined that any of the following conditions have been met:

(A) The complaint information has a direct and immediate relationship to the health and safety of another person.

(B) The complaint involves a dangerous act or condition caused by the subject of the complaint that has or could result in death, bodily injury or severe consequences and disclosure may protect the consumer and/or prevent additional harm to the public.

(C) A series of complaints against a registrant or licensee has been received by the bureau, alleging a pattern of unlawful activity, and it has been determined that disclosure may help to protect the consumer and/or prevent additional harm to the public.

(D) The complaint has resulted in the issuance of a citation by the bureau.

(E) The allegations in the complaint are part of an administrative action that has been referred to the Attorney General for filing of an Accusation or Statement of Issues.

(F) The complaint has been referred to a law enforcement agency for prosecution.

(2) The bureau will not provide copies of actual complaints and no personal information will be disclosed. Information about a complaint will not be disclosed if it is determined by the Chief or the Chief's designee, that any of the following apply:

(A) Disclosure is prohibited by statute or regulation.  
 (B) Disclosure might compromise any investigation or prosecution.

(C) Disclosure might endanger or injure the complainant or a third party.

(3) When the conditions for disclosure listed in paragraph (1) of this subsection have been met, and none of the conditions listed in paragraph (2) are found to be applicable, the bureau will disclose the following information regarding complaints received against registrants or licensees:

(A) The total number of complaints that meet the conditions for disclosure.

(B) The date of receipt and the nature of each disclosable complaint.

(C) The disposition of each disclosable complaint, indicating whether the matter has been:

1. referred for administrative action;
2. disposed of through any other action, formal or informal; or
3. resolved by other disposition.

(D) Information that is statutorily mandated to be disclosed.

(E) A description of the type of public information not included (i.e., civil judgements, criminal convictions, unsubstantiated complaints).

(4) All disclosures of complaint information shall include disclaimers indicating that the disclosure does not constitute endorsement or non-endorsement of the registrant or licensee, and that not all available information may be included.

(d) For the purposes of this section, “administrative action” shall mean an Accusation or Statement of Issues filed by the bureau, or a Citation issued by the bureau.

**AUTHORITY:**

**Note:** Authority cited: Section 9882, Business and Professions Code; and Sections 6253 and 6253.4, Government Code. Reference: Sections 27, 129 and 9882, Business and Professions Code; and Sections 6253, 6253.1 and 6254, Government Code.

**HISTORY**

1. New section filed 6-5-81; effective thirtieth day thereafter (Register 81, No. 23).
2. Amendment of section heading, repealer and new section and amendment of Note filed 6-20-2007; operative 7-20-2007 (Register 2007, No. 25).

**§ 3303.2. Review of Applications for Licensure, Registration and Certification; Processing Time.**

(a) An applicant for an initial license, registration or certification shall be informed in writing within 14 days whether the application is complete and accepted for filing or is incomplete and what specific information is required.

(b) An applicant for initial licensure as an official lamp, brake or smog check station shall be informed in writing, within 45 days after completion of the application, of the bureau’s decision whether the applicant meets the requirements for licensure. Inspection of the applicant’s station shall be performed during that time period. In the event that the inspection indicates a deficiency, the time period may be extended by that time necessary for correcting the deficiency.

(c) An applicant for initial licensure as a smog check technician shall be informed in writing, within 70 days after completion of the application, of the bureau’s decision whether the applicant meets the requirements to take the technician examination.

(d) An applicant for initial licensure as an adjuster shall be informed in writing, within 70 days after completion of the application, of the bureau’s decision whether the applicant meets the requirements for licensure. This period may be extended by the time necessary for rescheduling an examination if the applicant fails the examination or fails to take the examination at the time first scheduled by the bureau.

(e) An applicant for initial registration as an automotive repair dealer shall be informed in writing, within 45 days after completion of the application, of the bureau’s decision whether the applicant meets the requirements for registration.

(f) An applicant for initial licensure as a fleet facility shall be informed in writing, within 15 days after completion of the application, of the bureau’s decision whether the applicant meets the requirements for licensure.

(g) An applicant for certification as an instructor of Smog check technicians shall be informed in writing, within 45 days after completion of the application, as to whether the applicant meets the requirements for certification.

(h) An applicant for initial certification as an institution providing training to Smog check technicians shall be informed in writing, within 70 days after completion of the application, of the bureau’s decision as to whether the applicant meets the requirements for certification. Inspection of the applicant’s training facility shall be performed during that time period. In the event that the inspection indicates a deficiency, the time period may be extended by that time necessary for correcting the deficiency.

(i) An applicant applying for certification as a Gold Shield station shall be informed in writing, within 45 days after the bureau has received a completed Gold Shield Application form (GSR-1 (08/05/97)) which is incorporated by reference, of the bureau’s decision that the station meets, or does not meet, the eligibility requirements, or the basis for disapproving the certification. Inspection of the applicant’s station shall be performed during that time period. In the event that the inspection indicates a deficiency, the time period may be extended by that time necessary for correcting the deficiency. A representative of the bureau may make an inspection of the applicant’s station. A certification may be issued only for an applicant that meets the specifications contained in Article 10, of this Chapter.

(j) “Completion of the application” as used in this section means that a completed application and required fees have been filed by the applicant and received by the bureau.

(k) The minimum, maximum and median processing times for initial licensure, or a Gold Shield (GS) station certification from the time of receipt of the initial application until the bureau made a final decision on the application, or the GS station certification were:

	Lamp Station	Brake Station	Smog Check Technician
(1) Minimum	14 days	15 days	21 days
(2) Median	20 days	21 days	50 days
(3) Maximum	44 days	29 days	120 days
	Lamp Adjuster	Brake Adjuster	
(1) Minimum	15 days	21 days	
(2) Median	52 days	50 days	
(3) Maximum	101 days	103 days	
	Auto-motive Repair Dealer	Smog Check Station	Technician Training Institution
(1) Minimum	17 days	3 days	10 days
(2) Median	39 days	22 days	61 days
(3) Maximum	97 days	120 days	347 days
	Fleet Facility	Smog Check Inspector	Technician Training Instructor
(1) Minimum	1 day	2 days	2 days
(2) Median	10 days	9 days	22 days
(3) Maximum	28 days	112 days	264 days
	Gold Shield Station		
(1) Minimum	30 days		
(2) Median	42 days		
(3) Maximum	72 days		

(l) An applicant for certification to blend, fill or sell emissions inspection system (EIS) calibration gases pursuant to section 44036.5 of the Health and Safety Code shall be informed in writing, within 70 days after completion of the application of the bureau's decision as to whether the applicant meets the requirements for certification. The minimum, maximum and median processing times for initial certification for such applicants from the time of receipt of the initial application until the bureau made a final decision on the application has been as follows:

(1) Minimum	40 days
(2) Median	53 days
(3) Maximum	73 days

**AUTHORITY:**

**Note:** Authority cited: Sections 9882 and 9887.1, Business and Professions Code; Sections 44001.5, 44002, 44014, 44031, 44036.5 and 44045.5, Health and Safety Code; and Section 15376, Government Code. Reference: Section 15376, Government Code; Section 44014.2, Health and Safety Code; and Section 20, Title 1, Government Code.

**HISTORY**

1. New section filed 11-25-83; effective thirtieth day thereafter (Register 83, No. 48).
2. Amendment filed 9-26-90; operative 10-26-90 (Register 90, No. 44).

3. Editorial correction of printing error of subsection (j) Brake Adjuster median from printed 21 to correct 50 days (Register 91, No. 46).
4. Amendment filed 8-20-91; operative 9-19-91 (Register 92, No. 1).
5. Amendment of subsection (c), new subsection (d), subsection relettering, and amendment of subsections (g)-(h) and Note filed 6-23-95 as an emergency; operative 6-23-95 (Register 95, No. 25). A Certificate of Compliance must be transmitted to OAL by 10-21-95 or emergency language will be repealed by operation of law on the following day.
6. Certificate of Compliance as to 6-23-95 order transmitted to OAL 10-20-95 and filed 12-6-95 (Register 95, No. 49).
7. New subsection (i), subsection relettering, amendment of newly designated subsection (k), and amendment of Note filed 4-23-97 as an emergency; operative 4-23-97 (Register 97, No. 17). A Certificate of Compliance must be transmitted to OAL by 8-21-97 or emergency language will be repealed by operation of law on the following day.
8. Certificate of Compliance as to 4-23-97 order, including further amendment of subsection (i), transmitted to OAL 8-19-97 and filed 9-30-97 (Register 97, No. 40).
9. Amendment of subsection (l) filed 6-9-2003; operative 7-9-2003 (Register 2003, No. 24).
10. Change without regulatory effect amending subsections (g)-(i) and (k)-(l) filed 10-11-2006 pursuant to section 100, title 1, California Code of Regulations (Register 2006, No. 41).

**§ 3303.3. Current Address Required.**

Each registrant or licensee of the bureau shall have on file at the principal office of the bureau his or her correct mailing and street address. A registrant or licensee shall within 14 days notify the bureau of any changes in mailing or street address giving both the old and new addresses.

**AUTHORITY:**

**Note:** Authority cited: Section 9882, Business and Professions Code; and Section 44002, Health and Safety Code. Reference: Sections 9882 and 9882.4, Business and Professions Code; and Section 44002, Health and Safety Code.

**HISTORY**

1. New section filed 4-16-90; operative 4-16-90 (Register 90, No. 19).

**§ 3303.4. Nondiscrimination Clause.**

**AUTHORITY:**

**Note:** Authority cited: Sections 9882, 9887.1, 9887.2 and 9888.2, Business and Professions Code; and Section 44030, Health and Safety Code. Reference: Sections 9880, 9880.2, 9888.1, 9888.2, 9888.3 and 9889.31, Business and Professions Code; Sections 44002, 44014, 44030, 44033 and 44034, Health and Safety Code; and Section 15376, Government Code.

**HISTORY**

1. New section filed 12-8-98 as an emergency; operative 12-8-98 (Register 98, No. 50). A Certificate of Compliance must be transmitted to OAL by 3-8-99 or emergency language will be repealed by operation of law on the following day.
2. Repealed by operation of Government Code section 11346.1(g) (Register 2000, No. 5).

**§ 3303.4.1. Applicant Compliance with PRWORA.**

**AUTHORITY:**

**Note:** Authority cited: Sections 9882, 9887.1, 9887.2 and 9888.2, Business and Professions Code; and Section 44030, Health and Safety Code. Reference: Sections 9880, 9880.2, 9888.1, 9888.2, 9888.3 and 9889.31, Business and Professions Code; Sections 44002, 44014, 44030, 44033 and 44034, Health and Safety Code; and Section 15376, Government Code.

**HISTORY**

1. New section filed 12-8-98 as an emergency; operative 12-8-98 (Register 98, No. 50). A Certificate of Compliance must be transmitted to OAL by 3-8-99 or emergency language will be repealed by operation of law on the following day.
2. Repealed by operation of Government Code section 11346.1(g) (Register 2002, No. 42).

#### § 3303.4.2. Requirements for Licensure for Certain Aliens.

##### AUTHORITY:

**Note:** Authority cited: Sections 9882, 9887.1, 9887.2 and 9888.2, Business and Professions Code; and Section 44030, Health and Safety Code. Reference: Sections 9880, 9880.2, 9888.1, 9888.2, 9888.3 and 9889.31, Business and Professions Code; Sections 44002, 44014, 44030, 44033 and 44034, Health and Safety Code; and Section 15376, Government Code.

##### HISTORY

1. New section filed 12-8-98 as an emergency; operative 12-8-98 (Register 98, No. 50). A Certificate of Compliance must be transmitted to OAL by 3-8-99 or emergency language will be repealed by operation of law on the following day.
2. Repealed by operation of Government Code section 11346.1(g) (Register 2002, No. 42).

#### § 3303.4.3. PRWORA Verification.

##### AUTHORITY:

**Note:** Authority cited: Sections 9882, 9887.1, 9887.2 and 9888.2, Business and Professions Code; and Section 44030, Health and Safety Code. Reference: Sections 9880, 9880.2, 9888.1, 9888.2, 9888.3 and 9889.31, Business and Professions Code; Sections 44002, 44014, 44030, 44033 and 44034, Health and Safety Code; and Section 15376, Government Code.

##### HISTORY

1. New section filed 12-8-98 as an emergency; operative 12-8-98 (Register 98, No. 50). A Certificate of Compliance must be transmitted to OAL by 3-8-99 or emergency language will be repealed by operation of law on the following day.
2. Repealed by operation of Government Code section 11346.1(g) (Register 2002, No. 42).

#### § 3303.4.4. No Refund of Application Fee.

##### AUTHORITY:

**Note:** Authority cited: Sections 9882, 9887.1 and 9887.2, Business and Professions Code. Reference: Sections 44034 and 44034.1, Health and Safety Code; Sections 158 and 163.5, Business and Professions Code; and Section 13142, Government Code.

##### HISTORY

1. New section filed 12-8-98 as an emergency; operative 12-8-98 (Register 98, No. 50). A Certificate of Compliance must be transmitted to OAL by 3-8-99 or emergency language will be repealed by operation of law on the following day.
2. Repealed by operation of Government Code section 11346.1(g) (Register 2002, No. 42).

## ARTICLE 2.

### Licensing of Official Stations and Adjusters

- § 3304. Scope of Regulations.
- § 3305. Station Performance, Work Area and Adjuster Required.
- § 3306. Licensing Official Stations; Inspection; Term, Renewal and Replacement of Licenses.
- § 3307. Display of Licenses and Posting of Prices; Equipment Maintenance; Records.
- § 3308. Official Station That Stops Operating As an Official Station.
- § 3309. Official Station Signs.
- § 3310. Licensing Official Lamp and Brake Adjusters.

#### § 3304. Scope of Regulations.

##### AUTHORITY:

**Note:** Authority cited: Section 9882, Business and Professions Code.

##### HISTORY

1. Repealer filed 2-22-83; effective thirtieth day thereafter (Register 83, No. 9).

#### § 3305. Station Performance, Work Area and Adjuster Required.

(a) All adjusting, inspecting, servicing, and repairing of brake systems and lamp systems for the purpose of issuing any certificate of compliance or adjustment shall be performed in official stations, by official adjusters, in accordance with the following, in descending order of precedence, as applicable:

(1) Vehicle Manufacturers' current standards, specifications and recommended procedures, as published in the manufacturers' vehicle service and repair manuals.

(2) Current standards, specifications, procedures, directives, manuals, bulletins and instructions issued by vehicle and equipment or device manufacturers.

(3) Standards, specifications and recommended procedures found in current industry-standard reference manuals and periodicals published by nationally recognized repair information providers.

(4) The bureau's Handbook for Brake Adjusters and Stations, February 2003, which is hereby incorporated by reference.

(5) The bureau's Handbook for Lamp Adjusters and Stations, February 2003, which is hereby incorporated by reference.

(b) The specific activities for which an official station is licensed shall be performed only in an area of the station that has been approved by the bureau. Other work may be performed in the approved area, as desired. The work area shall be within a building and shall be large enough to accommodate the motor vehicle being serviced. The bureau may make an exception to the preceding requirement by approving a work area adjacent to a building for purposes of inspecting and adjusting equipment and devices on buses, trucks, truck tractors, trailers, and semitrailers. The work area shall be kept clean and orderly.

(c) The services of an officially licensed adjuster appropriate to each type and class of station license held shall be available at each official station, except a fleet owner station, not less than 40 hours weekly or not less than half of the hours the station is open for business weekly, whichever is less. Fleet owner stations are required to provide the services of a licensed adjuster only for certification procedures.

##### AUTHORITY:

**Note:** Authority cited: Sections 9882, 9887.1 and 9888.2, Business and Professional Code. Reference: Sections 9888.2 and 9888.4, Business and Professions Code.

##### HISTORY

1. Amendment filed 2-22-83; effective thirtieth day thereafter (Register 83, No. 9).
2. Amendment of subsections (a) and (c) filed 5-11-90; operative 6-10-90 (Register 90, No. 26).
3. Editorial correction of History 2. (Register 91, No. 30).
4. Amendment of subsection (a) filed 8-20-91; operative 9-19-91 (Register 92, No. 1).
5. Editorial correction of subsection (b), restoring inadvertently omitted text (Register 2002, No. 23).
6. Amendment of section heading and section filed 1-23-2007; operative 2-22-2007 (Register 2007, No. 4).

#### § 3306. Licensing Official Stations; Inspection; Term, Renewal and Replacement of Licenses.

Official station licenses shall be issued and renewed in accordance with the following procedures:

(a) Licenses will be issued only after an on-site inspection of the station by a bureau representative confirms that the applicant meets the qualifications prescribed in these regulations. A station license shall expire one year from date of issue.

(b) The late renewal fee shall be \$7.50 if the bureau receives the renewal application within 30 days after the date of expiration.

(c) In the event of a change of ownership of a licensed business, a new *Application for Station License*, Form R-4 (Rev 11/05), which is hereby incorporated by reference, and a fee of \$10 shall be submitted to the bureau. In determining whether a fee is required, the following shall apply:

(1) "Change of ownership" means any change in legal ownership of the license or the licensed business, including the addition or the deletion of a partner, the transfer of any ownership interest between members of a family (such as by sale, gift, or the death of the legal owner or one of the owners), change of the business entity by incorporation of the business or a change in the corporate status that requires a new corporate number as issued by the Secretary of State.

(2) "Change of address" means any relocation of a licensed business not involving a change of ownership and any change in the mailing address, including a change resulting from street renumbering.

**AUTHORITY:**

**Note:** Authority cited: Sections 9882 and 9887.1, Business and Professions Code. Reference: Sections 152.6, 163.5, 9887.1, 9887.2 and 9887.3, Business and Professions Code.

**HISTORY:**

1. Amendment filed 6-26-74; designated effective 8-1-74 (Register 74, No. 26).
2. Amendment of subsection (e)(2) filed 5-8-75; effective thirtieth day thereafter (Register 75, No. 19).
3. Amendment filed 12-23-76; effective thirtieth day thereafter (Register 76, No. 52).
4. Amendment of subsection (a) filed 6-9-78; effective thirtieth day thereafter (Register 78, No. 23).
5. Amendment filed 2-22-83; effective thirtieth day thereafter (Register 83, No. 9).
6. Editorial correction of printing error inadvertently misstating authority section (Register 91, No. 6).
7. Amendment of section heading and section filed 1-23-2007; operative 2-22-2007 (Register 2007, No. 4).
8. Amendment of subsection (c) filed 2-1-2012; operative 2-1-2012 pursuant to Government Code section 11343.4 (Register 2012, No. 5).

**§ 3307. Display of Licenses and Posting of Prices; Equipment Maintenance; Records.**

Official stations shall comply with the following provisions governing display of licenses, maintenance of equipment, and record keeping.

(a) An official station license shall be placed under glass or other transparent cover and prominently displayed in an area of the station frequented by customers.

(b) Licenses of all official adjusters employed at a licensed station shall be mounted under glass or other transparent cover and prominently displayed in an area of the station frequented by customers.

(c) Each official station, except a fleet owner station, shall display an official station sign that meets the specifications in section 3309, and the sign shall be displayed in a location where it is clearly visible to the general public from outside the station.

(d) Each official station, except a fleet owner station, may make a reasonable charge for the work performed and shall post conspicuously, in an area frequented by customers, a list of prices for the specific activities for which it is licensed. Prices may be stated either as a fixed fee or an hourly rate on a time-and-material basis. No added charge shall be imposed for the issuance of official lamp adjustment or official brake adjustment certificates, or certifications on enforcement documents of the correction of lamp or brake violations. No charge relating to repair, replacement of parts, or adjustment of lamps or brakes shall be imposed in addition to the posted price for such adjustment or inspection unless such additional work and added charges are authorized in advance by the vehicle owner or operator.

(e) All adjusting, servicing, and testing instruments, machines, devices and equipment shall be maintained in good condition. Instruments, machines, devices and equipment requiring calibration or adjustment shall be calibrated or adjusted in accordance with the instructions of the manufacturers and the requirements of the bureau.

(f) Each licensee shall make, keep, and have available for inspection upon request of the bureau, records showing the transactions as a licensee for a period of not less than three (3) years after completion of any transaction to which the records refer, including, but not limited to, records of all lamp adjustment certificates and brake adjustment certificates issued by the licensee.

**AUTHORITY:**

**Note:** Authority cited: Sections 9882.2, Business and Professional Code. Reference: Sections 9884.11, 9888.2 and 9888.3, Business and Professional Code.

**HISTORY:**

1. Amendment of subsection (f) filed 6-26-74; designated effective 8-1-74 (Register 74, No. 26).
2. Amendment of subsection (e) filed 7-25-75; effective thirtieth day thereafter (Register 75, No. 30).
3. Amendment filed 12-23-76; effective thirtieth day thereafter (Register 76, No. 52).
4. Amendment of subsection (e) filed 2-22-83; effective thirtieth day thereafter (Register 83, No. 9).
5. Amendment of subsections (b), (d) and (f) filed 5-11-90; operative 6-10-90 (Register 90, No. 26).
6. Editorial correction of printing error restoring subsection (f) (Register 91, No. 45).
7. Editorial correction amending subsection (d) (Register 2003, No. 8).
8. Amendment of section heading and section filed 1-23-2007; operative 2-22-2007 (Register 2007, No. 4).

**§ 3308. Official Station That Stops Operating As an Official Station.**

An official station shall stop performing the functions for which it has been licensed when it no longer has the services of a licensed adjuster, or when its station license has expired or has been surrendered, suspended, or revoked. The station must dispose of materials related to its formerly licensed activity according to these provisions.

(a) An official station that no longer has the services of a licensed adjuster shall immediately remove or cover the official station sign in accordance with subsection (b) of this section. If the station does not employ a licensed adjuster within 60 days, the station shall surrender its official station license to the bureau and shall return to the bureau all unused certificates of adjustments bought



by the station to carry out the function for which it is no longer licensed.

(b) An official station that is no longer authorized to perform the function for which it has been licensed shall remove or cover the sign pertaining to the licensed function. A station that has a multipurpose sign shall cover those portions of the sign that pertain to the functions for which it is no longer licensed.

(c) When an official station license has expired or has been surrendered, suspended, or revoked, the station shall return to the bureau all unused certificates purchased by the station to carry out the function for which it is no longer licensed.

**AUTHORITY:**

**Note:** Authority cited: Sections 9882, 9887.1 and 9888.2, Business and Professional Code. Reference: Sections 9887.1, 9888.2 and 9889.7, Business and Professional Code.

**HISTORY**

1. Repealer and new section filed 2-22-83; effective thirtieth day thereafter (Register 83, No. 9).
2. Amendment filed 5-11-90; operative 6-10-90 (Register 90, No. 26).
3. Amendment filed 1-23-2007; operative 2-22-2007 (Register 2007, No. 4).

**§ 3309. Official Station Signs.**

Official station signs shall meet the specifications illustrated in this section and shall be displayed in accordance with subsection (c) of section 3307 of this article. A station that performs more than one official function may display a separate sign to designate each function or it may display one multipurpose sign appropriate to the official functions for which the station is licensed.

(a) Official station signs displayed separately to designate each function for which the station is licensed shall meet the following specifications:

- (1) Single function signs shall have the dimensions shown in Figure 1.
- (2) Single function signs shall be bordered and lettered in light chrome yellow; and the background shall be royal blue.
- (3) Single function signs shall have lettering dimensions shown in Figure 2.

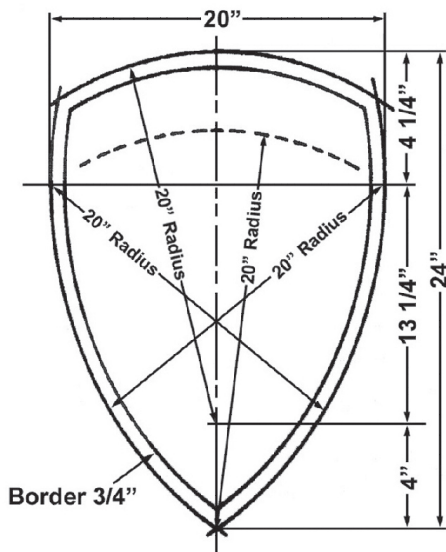

FIGURE 1. SIGN DIMENSIONS

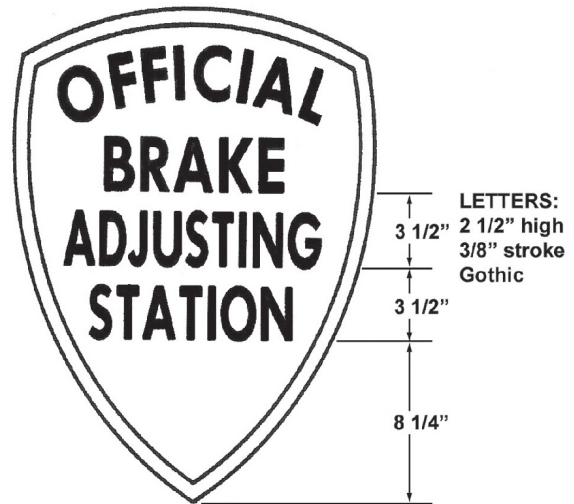

FIGURE 2. LETTERING DIMENSIONS

(b) Multipurpose station signs displayed to designate the functions for which the station is licensed shall meet the following specifications:

- (1) Multipurpose signs shall have the overall dimensions, shield size, placement, and lettering size shown in Figures 3 and 4.
- (2) Multipurpose signs shall have lettering, shield border and station designation(s) in light chrome yellow; and the background shall be royal blue.
- (3) The space to the right of the official station shield in a multipurpose sign shall be used to designate the official functions of the station, and such designation shall meet the requirements of paragraph (1) of subsection (b) of this section.

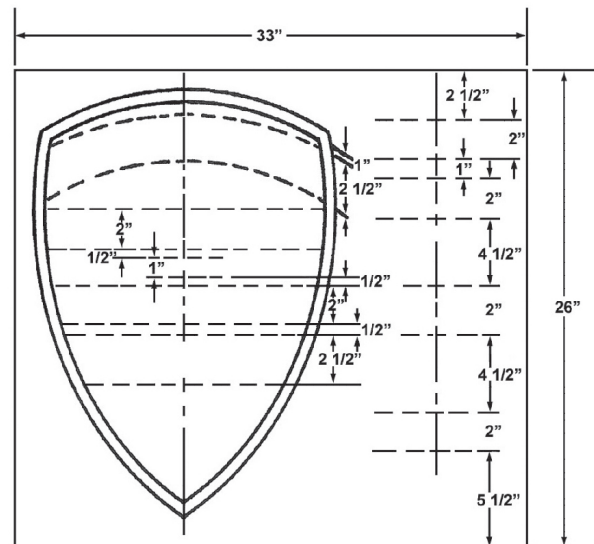

FIGURE 3. DIMENSIONS, MULTIPURPOSE SIGN

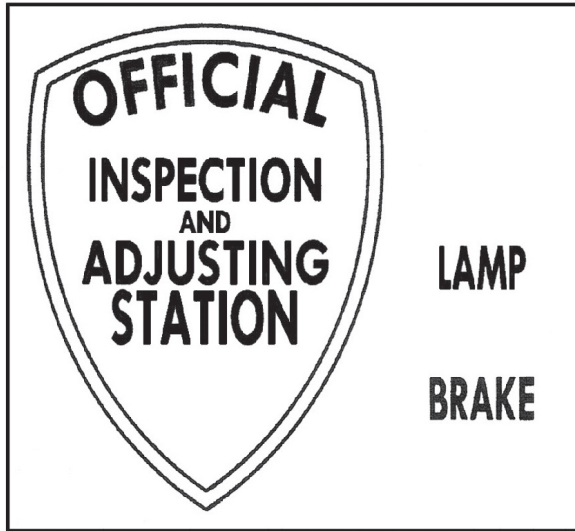

FIGURE 4. MULTIPURPOSE SIGN

**AUTHORITY:**

**Note:** Authority cited: Sections 9882 and 9888.2, Business and Professions Code. Reference: Section 9888.2, Business and Professions Code.

**HISTORY**

1. Repealer of subsection (c) filed 2-22-83; effective thirtieth day thereafter (Register 83, No. 9).
2. Amendment filed 5-11-90; operative 6-10-90 (Register 90, No. 26).
3. Amendment of FIGURES 2 and 4 filed 10-23-91; operative 11-22-91 (Register 92, No. 35).
4. Amendment filed 1-23-2007; operative 2-22-2007 (Register 2007, No. 4).

**§ 3310. Licensing Official Lamp and Brake Adjusters.**

(a) There shall be one class of official lamp adjusters' license. Official lamp adjusters' licenses may be issued to persons who have shown by examination that they are qualified to test, inspect, adjust, and repair the lamps and related electrical systems on all vehicles.

(b) There shall be three classes of official brake adjusters' licenses:

(1) Class A official brake adjusters' licenses may be issued to persons who have shown by examination that they are qualified to test, inspect, adjust, and repair the brakes and brake system on all vehicles.

(2) Class B official brake adjusters' licenses may be issued to persons who have shown by examination that they are qualified to test, inspect, adjust, and repair all brakes and brake systems on all buses, trucks, and truck tractors, trailers, and semitrailers.

(3) Class C official brake adjusters' licenses may be issued to persons who have shown by examination that they are qualified to test, inspect adjust, and repair all brakes and brake systems on all trucks and truck tractors having a manufacturer's gross vehicle weight rating of less than 10,000 pounds and all trailers and semitrailers which do not use compressed air or vacuum to actuate the brakes, and all passenger vehicles including motorcycles and motor-driven cycles.

(c) A person desiring to be licensed as an official adjuster shall submit a separate Brake Adjuster or Lamp Adjuster Application form, Lic (Rev.8/00), which is in-

corporated by reference, for each license or license class desired. A separate license shall be required for each license type or license class.

(d) Each application shall be accompanied by the fee prescribed in section 9887.2 of the Business and Professions Code, except that the late renewal fee shall be \$7.50 if the bureau receives the renewal application within 30 days after the date of expiration. An applicant who fails the examination may submit an application for another examination and in each such instance shall pay the prescribed application fee.

(e) Official adjusters' licenses shall expire four years from date of issue. When any person licensed as an adjuster ceases to be employed at an official station, the person's right to act as an official adjuster shall immediately cease. The person shall not engage in the activity of official adjuster until the person is again employed at an appropriate official station.

**AUTHORITY:**

**Note:** Authority cited: Sections 9882, 9887.1, 9887.2 and 9888.2, Business and Professions Code. Reference: Sections 163.5, 9887.1, 9887.2 and 9888.2, Business and Professions Code.

**HISTORY**

1. Amendment of subsections (d), (e), (f) and (g) filed 10-4-72 as an emergency; effective upon filing (Register 72, No. 41).
2. Certificate of Compliance filed 12-22-72 (Register 72, No. 52).
3. Amendment filed 2-22-83; effective thirtieth day thereafter (Register 83, No. 9).
4. Amendment filed 5-11-90; operative 6-10-90 (Register 90, No. 26).
5. Editorial correction of subsection (b)(3) (Register 2002, No. 23).
6. Amendment filed 1-23-2007; operative 2-22-2007 (Register 2007, No. 4).

**ARTICLE 3.**

**Official Lamp Adjusting Stations**

- § 3315. Classes of Official Lamp Adjusting Stations.
- § 3316. Lamp Adjusting Station Operation and Equipment Requirements.

**§ 3315. Classes of Official Lamp Adjusting Stations.**

Classes of official lamp adjusting stations are established as follows:

(a) Class A official lamp adjusting stations shall be equipped to test, inspect, adjust, and repair all lamps and related electrical systems on all vehicles.

(b) Class B-limited (BL) official lamp adjusting stations shall be equipped to adjust all lamps with aiming pads on all passenger vehicles and commercial vehicles 80 inches or less in width. These stations shall be equipped to test, inspect, and repair all lamps and related electrical systems on all vehicles except motorcycles and motor-driven cycles.

**AUTHORITY:**

**Note:** Authority cited: Sections 9882, 9887.1 and 9888.2, Business and Professions Code. Reference: Sections 9887.1, 9887.2, 9887.3 and 9888.2, Business and Professions Code.

**HISTORY**

1. Amendment filed 2-22-83; effective thirtieth day thereafter (Register 83, No. 9).
2. Amendment filed 1-23-2007; operative 2-22-2007 (Register 2007, No. 4).

**§ 3316. Lamp Adjusting Station Operation and Equipment Requirements.**

The operation of official lamp adjusting stations shall be subject to the following provisions:

(a) Class A official lamp adjusting stations shall provide an aiming screen or an optical type headlamp-aiming machine. Class A stations may provide, in addition, a mechanical type headlamp aiming machine and related calibration equipment. A Class BL station that limits its lamp aiming to lamps with aiming pads shall provide a mechanical type headlamp aiming machine and related calibration equipment.

Each official lamp adjusting station shall be equipped with a voltmeter and other tools necessary for proper lamp servicing.

(b) Equipment for aiming headlamps and auxiliary-lamps shall be approved by the bureau. Aiming equipment shall be used only in the work area prescribed in subsection (b) of Section 3305 of this chapter, and as follows:

(1) Aiming screens may be used for all headlamps and auxiliary lamps. Provision shall be made so that the screen can be shaded sufficiently from both direct and ambient light during daylight hours to perform aiming functions adequately.

(2) Optical type headlamp aiming machines may be used for all headlamps and auxiliary lamps.

(3) Mechanical type headlamp aiming machines shall be used only for lamps manufactured with three aiming pads on the lens.

(c) Each official lamp adjusting station shall maintain in a location readily accessible to licensed adjusters a current copy of the following:

(1) The bureau's Handbook for Lamp Adjusters and Stations, referenced in subsection (a) of Section 3305 of this Chapter.

(2) All appropriate and current lamp adjustment standards, specifications, directives, manuals, bulletins and instructions issued by motor vehicle and lamp manufacturers that are applicable to vehicles for which the station adjusts lamps.

(3) Service manuals and operating instructions issued by the manufacturers for all headlamp aiming instruments, machines, devices and equipment used by the station.

(d) Effective April 1, 1999, licensed stations shall purchase certificates of adjustment from the bureau for a fee of three dollars and fifty cents (\$3.50) each and shall not purchase or otherwise obtain such certificates from any other source. Full payment is required at the time certificates are ordered. Certificates are not exchangeable following delivery. A licensed station shall not sell or otherwise transfer unused certificates of adjustment. Issuance of a lamp adjustment certificate shall be in accordance with the following provisions:

(1) When a lamp adjustment certificate is issued to an applicant for an authorized emergency vehicle permit, the certificate shall certify that the vehicle has been inspected, that all lamps and related electrical systems meet all requirements of the Vehicle Code and bureau regulations, and that all lamps capable of adjustment are properly adjusted.

(2) Where all of the lamps, lighting equipment, and related electrical systems on a vehicle have been inspected and found to be in compliance with all requirements of the Vehicle Code and bureau regulations, the certificate shall certify that the entire system meets all of those requirements.

(3) When a customer asks for a certificate of lamp adjustment in conjunction with clearance of an enforcement form, the adjuster may, if requested, inspect and certify only the portion of the lighting system specified as defective on the enforcement form. Where the entire system has not been tested or inspected or one or more defects have been corrected, the certificate shall indicate which tests or inspections have been performed, or which defect or defects have been corrected.

(4) A certificate shall be valid for 90 days after its issuance to a consumer.

(e) After correcting specified defects, official lamp adjusters shall certify that defects indicated on citations or other enforcement forms have been corrected.

(1) The adjuster shall inform the customer of any other defective conditions present or likely to occur in the future, which have come to the adjuster's attention in conjunction with inspection of the vehicle and correction of specified defects.

(2) If the customer does not authorize additional repairs to correct other defects found during the inspection, the adjuster shall certify that only the specific defects listed on the enforcement form have been corrected.

(3) Only a licensed adjuster employed at an official adjusting station may sign an enforcement form as an official adjuster. The adjuster's license number, class, and official station number shall be included with the signature.

(4) Certification by a licensed adjuster on an enforcement form that a violation has been corrected shall include the date of correction, the station's and the adjuster's license numbers, and the adjuster's signature.

**AUTHORITY:**

**Note:** Authority cited: Sections 9882, 9887.1 and 9888.2, Business and Professions Code; Reference: Sections 9887.1, 9888.2, 9889.16 and 9889.19, Business and Professions Code; and Section 40616, Vehicle Code.

**HISTORY**

1. Amendment of subsection (d) filed 8-16-73 as an emergency; effective upon filing (Register 73, No. 33).
2. Certificate of Compliance filed 12-4-73 (Register 73, No. 49).
3. Amendment filed 12-23-76; effective thirtieth day thereafter (Register 76, No. 52).
4. Amendment of subsection (d), repealer of subsection (e) and relettering and amendment of subsection (f) to subsection (e) filed 3-11-81; effective thirtieth day thereafter (Register 81, No. 11).
5. Amendment of subsection (d) filed 10-20-81; effective thirtieth day thereafter (Register 81, No. 43).
6. Amendment filed 2-22-83; effective thirtieth day thereafter (Register 83, No. 9).
7. Amendment of subsection (d) filed 7-12-85; effective upon filing pursuant to Government Code Section 11346.2(d) (Register 85, No. 28).
8. Amendment of subsection (d) filed 3-28-86; effective thirtieth day thereafter (Register 86, No. 13).
9. Editorial correction of printing error in subsection (d)(2) (Register 91, No. 6).
10. New subsection (d)(4) filed 10-23-91; operative 11-22-91 (Register 92, No. 35).
11. Amendment of subsection (d) filed 4-1-99; operative 4-1-99 pursuant to Government Code section 11343.4(d) (Register 99, No. 14).
12. Editorial correction of subsection (d) (Register 99, No. 16).

13. Amendment of section heading and section filed 1-23-2007; operative 2-22-2007 (Register 2007, No. 4).

#### ARTICLE 4.

### Official Brake Adjusting Stations

§ 3320. Classes of Official Brake Adjusting Stations.

§ 3321. Brake Adjusting Station Operation and Equipment Requirements.

#### § 3320. Classes of Official Brake Adjusting Stations.

Classes of official brake adjusting stations are established as follows:

(a) Class A official brake adjusting stations shall be equipped to test, inspect, adjust, and repair all brakes and brake systems on all vehicles.

(b) Class B official brake adjusting stations shall be equipped to test, inspect, adjust, and repair all brakes and brake systems on all buses, trucks, truck tractors, trailers, and semitrailers.

(c) Class C official brake adjusting stations shall be equipped to test, inspect, adjust, and repair all brakes and brake systems on all trucks or truck tractors having a manufacturer's gross vehicle weight rating of less than 10,000 pounds, all trailers and semitrailers that do not use compressed air or vacuum to actuate the brakes, and all passenger vehicles including motorcycles and motor-driven cycles.

#### AUTHORITY:

**Note:** Authority cited: Sections 9882, 9887.1 and 9888.2, Business and Professions Code. Reference: Sections 9887.1, 9887.3 and 9888.2, Business and Professions Code.

#### HISTORY

1. Amendment filed 2-22-83; effective thirtieth day thereafter (Register 83, No. 9).

2. Amendment filed 1-23-2007; operative 2-22-2007 (Register 2007, No. 4).

#### § 3321. Brake Adjusting Station Operation and Equipment Requirements.

The operation of official brake adjusting stations shall be subject to the following provisions:

(a) Each station shall be equipped with the following tools according to the class of station.

(1) All stations shall be equipped with:

(A) Suitable hand tools.

(B) A brake drum diameter gauge capable of measuring increments of 0.005 inch.

(C) A disc brake rotor thickness gauge capable of measuring increments of 0.001 inch.

(D) A disc brake rotor runout gauge capable of measuring increments of 0.001 inch.

(E) Brake lining gauges capable of measuring thickness of remaining usable brake lining either in fractions of an inch or in percentage of lining remaining.

(F) Torque wrenches capable of measuring torsion in accordance with vehicle manufacturer's installation and adjustment specifications.

(2) Class A and B stations shall be equipped with:

(A) A vacuum brake test kit with a gauge capable of measuring in inches of mercury

(B) An airbrake pressure test gauge accurate to ±1 psi.

(b) Each station shall maintain in a location readily accessible to its licensed adjusters a current copy of the following:

(1) The bureau's Handbook for Brake Adjusters and Stations, referenced in subsection (a) of Section 3305 of this Chapter.

(2) All appropriate and current standards, specifications, directives, manuals, bulletins, and instructions issued by motor vehicle, brake, and brake equipment manufacturers that are applicable to vehicles for which the station adjusts brakes.

(3) Service manuals and operating instructions issued by the manufacturers for all brake inspection tools, instruments, machines, devices and equipment used by the station.

(c) Effective April 1, 1999, licensed stations shall purchase certificates of adjustment from the bureau for a fee of three dollars and fifty cents (\$3.50) and shall not purchase or otherwise obtain such certificates from any other source. A licensed station shall not sell or otherwise transfer unused certificates of adjustment. Full payment is required at the time certificates are ordered. Certificates are not exchangeable following delivery. Issuance of a brake adjustment certificate shall be in accordance with the following provisions:

(1) When a brake adjustment certificate is issued to an applicant for an authorized emergency vehicle permit, the certificate shall certify that the vehicle has been road-tested and that the entire braking system meets all requirements of the Vehicle Code and bureau regulations.

(2) Where the entire brake system on any vehicle has been inspected or tested and found to be in compliance with all requirements of the Vehicle Code and bureau regulations, and the vehicle has been road-tested, the certificate shall certify that the entire system meets all such requirements.

(3) When a customer asks for a certificate of brake adjustment in conjunction with clearance of an enforcement form, the adjuster may, if requested, inspect and certify only the portion of the brake system specified as defective on the enforcement form. Where the entire system has not been tested or inspected or one or more defects have been corrected, the certificate shall indicate which tests or inspections have been performed, or which defect or defects have been corrected.

(4) A certificate shall be valid for 90 days after its issuance to a consumer.

(d) After correcting specified defects, official brake adjusters shall certify that defects indicated on citations or other enforcement forms have been corrected.

(1) The adjuster shall inform the customer of any other defective conditions present or likely to occur in the future, which have come to the adjuster's attention in conjunction with inspection of the vehicle and correction of specified defects. The adjuster shall inform the customer of the percentage of braking material left on pads/shoes, as appropriate.

(2) If the customer does not authorize additional repairs to correct other defects found during the inspection, the adjuster shall certify that only the specific defects listed on the enforcement form have been corrected.

(3) Only a licensed adjuster employed at an official adjusting station may sign an enforcement form as an official adjuster. The adjuster's license number, the license class, and the official station license number shall be included with the signature.

(4) Certification by a licensed adjuster on an enforcement form that a violation has been corrected shall include the date of correction, the station's and the adjuster's license numbers, and the adjuster's signature.

**AUTHORITY:**

**Note:** Authority cited: Sections 9882, 9887.1 and 9888.2, Business and Professions Code. Reference: Sections 9887.1, 9888.2 and 9889.16, Business and Professions Code; and Section 40616, Vehicle Code.

**HISTORY**

1. Amendment of subsection (c) filed 8-16-73 as an emergency, effective upon filing (Register 73, No. 33).
2. Certificate of Compliance filed 12-4-73 (Register 73, No. 49).
3. Amendment filed 12-23-76; effective thirtieth day thereafter (Register 76, No. 52).
4. Amendment of subsection (c) filed 10-20-81; effective thirtieth day thereafter (Register 81, No. 43).
5. Amendment filed 2-22-83; effective thirtieth day thereafter (Register 83, No. 9).
6. Amendment of subsection (c) filed 7-12-85; effective upon filing pursuant to Government Code Section 11346.2(d) (Register 85, No. 28).
7. Amendment of subsection (c) filed 3-28-86; effective thirtieth day thereafter (Register 86, No. 13).
8. New subsection (c)(4) filed 10-23-91; operative 11-22-91 (Register 92, No. 35).
9. Amendment of subsection (c) filed 4-1-99; operative 4-1-99 pursuant to Government Code section 11343.4(d) (Register 99, No. 14).
10. Amendment of section heading and section filed 1-23-2007; operative 2-22-2007 (Register 2007, No. 4).

**ARTICLE 5.**

**Official Motor Vehicle Pollution Control Device Installation and Inspection Stations**

**HISTORY**

1. Repealer of article 5 (sections 3325-3330) filed 5-11-90; operative 6-10-90 (Register 90, No. 26). For prior history of sections 3328 and 3329, see Register 83, No. 9; for prior history of section 3330, see Register 77, No. 30.

**ARTICLE 5.5.**

**Motor Vehicle Inspection Program**

- § 3340.1. Definitions.
- § 3340.4. Smog Check Referee Services.
- § 3340.5. Vehicles Exempt from Inspections.
- § 3340.6. Vehicles Subject to Inspection upon Change of Ownership and Initial Registration in California.
- § 3340.7. Fee for Inspection at State-Contracted Test-Only Facility.
- § 3340.8. Economic Hardship Extension.
- § 3340.9. Repair Assistance Program.
- § 3340.10. Licensing of Smog Check Stations.
- § 3340.15. General Requirements for Smog Check Stations.
- § 3340.16. Test-Only Station Requirements.
- § 3340.16.4. Repair-Only Station Requirements.
- § 3340.16.5. Test-and-Repair Station Requirements.
- § 3340.16.6. Requirement for Telephone Line.
- § 3340.16.7. Test Equipment and Electronic Transmission Requirements.
- § 3340.17. Test Equipment, Electronic Transmission, Maintenance and Calibration Requirements.
- § 3340.17.1. Decertification of Equipment Manufactures.
- § 3340.17.2. Citations and Informal Citation Conference.
- § 3340.18. Certification of Emissions Inspection System Calibration Gases and Blenders of Gases.
- § 3340.20. Acknowledgment and Waiver Requirement for Licensed Test-and-Repair Stations.
- § 3340.22. Smog Check Station Signs.
- § 3340.22.1. Smog Check Station Service Signs.
- § 3340.22.2. Smog Check Station Repair Cost Limit Sign.

- § 3340.22.3. Replacement of Signs.
- § 3340.23. Licensed Smog Check Station That Ceases Operating As a Licensed Station.
- § 3340.24. Suspension, Revocation, and Reinstatement of Licenses.
- § 3340.25. Licensing of Inspectors.
- § 3340.28. Licenses and Qualifications for Smog Check Inspectors and Repair Technicians.
- § 3340.29. Licensing of Smog Check Inspectors and Repair Technicians.
- § 3340.30. General Requirements for Smog Check Inspectors and/or Repair Technicians.
- § 3340.31. Retraining of Licensed Smog Check Inspectors and/or Repair Technicians.
- § 3340.32. Standards for the Certification of Institutions Providing Retraining to Licensed Technicians or Prerequisite Training to Those Seeking to Become Licensed Technicians.
- § 3340.32.1. Standards for the Decertification and Recertification of Institutions Providing Retraining to Licensed Technicians or Prerequisite Training to Those Seeking to Become Licensed Technicians.
- § 3340.33. Standards for the Certification of Basic and Advanced Instructors Providing Retraining to Intern, Basic Area, and Advanced Emission Specialist Licensed Technicians or Prerequisite Training to Those Seeking to Become Intern, Basic Area, or Advanced Emission Specialist Licensed Technicians.
- § 3340.33.1. Standards for the Decertification and Recertification of Instructors Providing Retraining to Licensed Technicians or Prerequisite Training to Those Seeking to Become Licensed Technicians.
- § 3340.34. Qualification Levels of Mechanics.
- § 3340.35. A Certificate of Compliance, Noncompliance, Repair Cost Waiver or an Economic Hardship Extension.
- § 3340.35.1. A Certificate of Compliance, Noncompliance, Repair Cost Waiver or an Economic Hardship Extension Fee Calculation.
- § 3340.36. Clearing Enforcement Forms.
- § 3340.36.1. Fee for Exhaust System Certificate of Compliance.
- § 3340.37. Installation of Oxides of Nitrogen (NOx) Devices.
- § 3340.38. Vehicle Registration Amnesty Program. [Repealed]
- § 3340.41. Inspection, Test, and Repair Requirements.
- § 3340.41.3. Invoice Requirements.
- § 3340.41.5. Tampering with Emissions Control Systems.
- § 3340.42. Smog Check Test Methods and Standards.
- § 3340.42.1. Mandatory Exhaust Emissions Inspection Standards and Test Procedures for Heavy-Duty Vehicles Powered by Gasoline.
- § 3340.42.2. Test Methods and Standards for the On-Board Diagnostic Inspection.
- § 3340.43. Repair Cost Limit.
- § 3340.45. Smog Check Manual.
- § 3340.50. Fleet Facility Requirements.
- § 3340.50.1. Application for Fleet Facility License; Renewal; Replacement.
- § 3340.50.3. Fleet Records and Reporting Requirements.
- § 3340.50.4. Fleet Certificates.
- § 3340.50.5. Suspension or Rescission of Fleet Facility License.

**§ 3340.1. Definitions.**

“Acceleration Simulation Mode” or “ASM” means a type of vehicle emissions test conducted with the test vehicle on a chassis dynamometer to simulate on-road acceleration operating conditions.

“After repairs test” means a test performed on a vehicle after repairs have been made to that vehicle as a result of failing an inspection at a smog check station.

“Alternative fuel retrofit system” means an after-market system certified by the California Air Resources Board to be installed on a vehicle to operate on an alternate fuel, in lieu of the fuel type specified by the original vehicle manufacturer.

“ARD-exempt heavy-duty station” means a smog check test-and-repair station or a smog check test-only station that only tests and/or repairs commercial vehicles which have a gross vehicle weight rating of 10,000 pounds or greater.

“Basic area” or “Basic vehicle inspection and maintenance program area” means the smog check program conducted in any area of the state which is not classified as an enhanced vehicle inspection and maintenance program area.

“BAR-97 Emissions Inspection System” or “EIS” means tamper-resistant test equipment meeting the requirements of subsection (a) of section 3340.17 of the California Code of Regulations and is certified by the bureau for use in the Smog Check Program. The EIS collects and measures emissions data, and where applicable OBD data, then transmits inspection results to the Vehicle Information Database.

“Bureau” or “BAR” means the Bureau of Automotive Repair.

“Chassis dynamometer” is a treadmill-like device for a vehicle that is used to simulate on-road acceleration operating conditions.

“Clean piping,” for the purposes of Health and Safety Code section 44072.10(c)(1), means the use of a substitute exhaust emissions sample in place of the actual test vehicle’s exhaust in order to cause the EIS to issue a certificate of compliance for the test vehicle.

“Comparative Failure Rate” or “CFR” means that the station’s failure rate, under the Gold Shield Program, must be comparable to the test-only station failure rate for all non-directed vehicles of the same model-year. The station’s failure rate, using initial tests, by model-year, of non-directed vehicles is applied to an industry-wide failure rate for test-only stations, calculated quarterly by smog check program area, using initial tests, by model-year, of non-directed vehicles inspected, and includes an allowable deviation to compensate for the random distribution of passing and failing vehicles based upon a 95 percent confidence level. This paragraph shall remain in effect through December 31, 2012.

“Consumer Assistance Program” or “CAP” means a program of the Bureau of Automotive Repair that provides eligible motor vehicle owners the options of Repair Assistance and Vehicle Retirement.

“Dismantler” means an automobile dismantler, as defined in Section 220 of the Vehicle Code and licensed pursuant to Section 11500 of the Vehicle Code, who has contracted with the Bureau to retire vehicles from operation.

“Engine change” means the installation of an engine in a vehicle that is different from the vehicle manufacturer original configuration as certified by the United States Environmental Protection Agency or California Air Resources Board.

“Enhanced area” or “Enhanced vehicle inspection and maintenance program area” means the smog check program conducted in any part of an urbanized area of the state which is classified by the Environmental Protection Agency as a serious, severe or extreme nonattainment area for ozone or a moderate or serious nonattainment area for carbon monoxide with a design value greater than 12.7 ppm.

“Excessive Test Deviation Rate” occurs under any of the following circumstances in a calendar quarter:

(1) The rate for which the ignition timing test is not performed exceeds the statewide average for similar vehicles where 90% of similar vehicles received the test.

(2) The rate for which the fuel cap test is not performed exceeds the statewide average for similar vehicles where 90% of similar vehicles received the test.

(3) The rate for which the low pressure fuel evaporative test is not performed exceeds the statewide average for similar vehicles where 90% of similar vehicles received the test.

(4) The rate for which the OBDII inspection is not performed exceeds the statewide average for similar vehicles where 90% of similar vehicles received the test.

(5) The rate for which inspections are aborted exceeds 125% of the statewide average for similar vehicles on test equipment of the same manufacturer.

(6) The rate for which inspections are restarted exceeds 125% of the statewide average for similar vehicles.

(7) The rate for which vehicles are initially inspected with the maximum allowable number of OBDII readiness monitors unset, as specified in Section 3340.42.2 (b), exceeds 125% of the statewide average for similar vehicles.

“Follow-up Pass Rate” (FPR) means a performance measure that evaluates whether vehicles previously certified by each station or technician are passing, in their current cycle, at higher than expected rates. Expected rates are calculated by averaging passing rates for similar vehicles, and then adjusting the rates to account for an individual vehicle’s odometer reading, the type of emissions inspection (ASM or TSI) performed in the current inspection cycle on the vehicle, the amount of time since the last certification for the vehicle, and the initial test results in the previous inspection cycle. An FPR score is assigned to both licensed smog check stations and technicians, and is based on the current inspection cycle test results of vehicles that were previously certified by stations and technicians. An FPR score ranges from zero to one, with zero representing the lowest possible score and one representing the highest possible score. FPR data reports are updated in January and July each year. Stations and technicians with insufficient inspection histories from which to calculate an FPR score will not receive an FPR score.

“Gaseous fuel” means fuel composed of propane, liquefied or compressed natural gas.

“Gear Shift Incident” means an inspection where data from the VID indicates the technician did not follow the gear selection procedure specified in the Smog Check Manual that is incorporated by reference in Section 3340.45.

“Gold Shield station” means a registered Automotive Repair Dealer who is also a smog check test-and-repair station which has been certified by the department and meets all the requirements specified in Article 10 of these regulations. This paragraph shall remain in effect through December 31, 2012.

“Heavy duty vehicle” means a vehicle with a manufacturer’s gross vehicle weight rating of 8501 pounds or more.

“Household” means a family of persons or any group of two or more unrelated persons that reside together and share common living expenses.

“Implementation area” means a geographical area, in which a local district has requested implementation of a

biennial inspection program pursuant to section 44003 of the Health and Safety Code.

“Initial test” means the first Smog Check inspection of a vehicle done in official test mode or pre-test mode and performed within one hundred eighty (180) days prior to a registration renewal date or a change of ownership date for that vehicle. An initial test does not include tests that are aborted before completion or tests done in the training or manual modes of the EIS.

“Non-directed vehicle” means a vehicle that was not required to be inspected at a station pursuant to Sections 44010.5 or 44014.7 of the Health and Safety Code.

“OBD Inspection System” or “OIS” consists of an OBD Data Acquisition Device or (DAD) working in conjunction with commercial off-the-shelf computer, bar code scanner, data entry device, and printer. The DAD is the test equipment that meets the requirements of subsection (b) of section 3340.17 of the California Code of Regulations and is certified by the bureau for use in the Smog Check Program. The DAD facilitates OBD data transfer between the inspected vehicle and the OIS computer. The OIS computer relays inspection information to and from the DAD to the Vehicle Information Database (VID).

“Repair Assistance” means a component of the Consumer Assistance Program (CAP) that provides financial assistance for emissions-related repairs to help eligible motor vehicle owners bring their vehicles into compliance with the requirements of the Smog Check Program.

“Repair-Only station” means a station licensed by the bureau to diagnose and repair vehicles in the smog check program.

“Revivable Junk Receipt” means a receipt showing proof that the vehicle is recorded and titled as “junked” by the Department of Motor Vehicles.

“Similar Vehicle Failure Rate” or “SVFR” means a calendar quarter comparison of the initial test failure rate of vehicles at an individual station to the initial test failure rate for similar vehicles inspected statewide, taking into account the vehicle odometer reading, time since passing the last inspection, and initial test results in the previous cycle. Vehicles for which data is not available to adequately establish an initial test failure rate will not be used in the SVFR calculation. This paragraph shall become effective July 1, 2012.

“Similar vehicles” means vehicles with the same Vehicle Lookup Table Row ID, or at a minimum, vehicles with the same model-year, make, and engine displacement.

“Smog Check Inspector” or “Inspector” means an individual licensed by the bureau to inspect, and certify the emissions control systems on vehicles subject to the Smog Check Program in all areas of the state.

“Smog check program” or “program” means the motor vehicles inspection program conducted pursuant to section 44005 of the Health and Safety Code, and as hereby described in this article.

“Smog Check Referee” or “Referee” means a facility under contract with BAR to provide independent evaluations of vehicles and services to accommodate vehicles with unusual inspection circumstances.

“Smog Check Repair Technician” or “Repair Technician” means an individual licensed by the bureau

to diagnose, adjust, and repair the emissions control systems on vehicles subject to the Smog Check Program at smog check stations in all areas of the state.

“Smog check station” or “station” means a smog check test-only station or smog check test-and-repair station licensed by the bureau in the smog check program.

“Smog check technician” or “technician” means an individual who holds a smog check repair technician and/or inspector licenses pursuant to section 3340.28 of this article.

“Smog check test-and-repair station” or “test-and-repair station” means a smog check station licensed by the bureau to test, inspect, diagnose and repair vehicles in the smog check program.

“Smog check test-only station” or “test-only station” means a smog check station licensed by the bureau to test and inspect vehicles in the smog check program.

“STAR” means a voluntary certification program that applies to a registered Automotive Repair Dealer that is also a licensed smog check test-and-repair station or a test-only station that meets all requirements specified in Article 10 of these regulations.

“Technician Information Table” means the bureau’s electronic list of licensed technicians authorized to perform official Smog Check inspections at a specific station.

“Test Deviation” occurs under any of the following conditions:

(1) The station fails to inspect ignition timing on a vehicle that should receive this test.

(2) The station fails to perform the fuel cap test on a vehicle that should receive this test.

(3) The station fails to perform the low pressure fuel evaporative test on a vehicle that should receive this test.

(4) The station fails to perform an OBDII inspection on a vehicle that should receive an OBDII inspection.

(5) The station aborts an inspection.

(6) The station restarts an inspection.

(7) The station performs an initial inspection on a vehicle with the maximum allowable number of OBDII readiness monitors unset, as specified in Section 3340.42.2 (b).

“Two-Speed Idle” or “TSI” means a type of vehicle emissions test conducted with the vehicle transmission in neutral or park while the engine is run at two different engine speeds.

“Vehicle Information Database” or “VID” means a centralized computer database and computer network, which is readily accessible by all licensed smog check technicians on a real time basis.

“Vehicle Inspection Report” or “VIR” means an official smog check inspection report that is printed from an OIS or EIS and given to the registered vehicle owner(s) or their legal representative.

“Vehicle Retirement” means a component of the Consumer Assistance Program (CAP) that provides payments to eligible motor vehicle owners who choose to voluntarily retire their vehicles from operation rather than make emissions-related repairs to bring the vehicles into compliance with the requirements of the Smog Check Program.

“VLT Row ID” means the vehicle lookup table row identification number that identifies a vehicle using in-

formation about its body type, model-year, make, model, engine displacement, and transmission type.

**AUTHORITY:**

**Note:** Authority cited: Sections 44001.5, 44002, 44072.10, 44091 and 44095, Health and Safety Code; and Section 9882, Business and Professions Code. Reference: Sections 44001.3, 44005, 44010.5, 44011, 44012, 44014, 44014.2, 44014.5, 44017, 44017.1, 44030, 44036, 44037.1, 44056, 44062.1, 44070, 44072.10, 44092, 44093, 44094 and 44103, Health and Safety Code; Sections 220 and 11500, Vehicle Code; and Section 11505, Government Code.

**HISTORY**

1. New article 5.5 (sections 3340.1-3340.50.5) filed 3-23-84; effective upon filing pursuant to Government Code section 11346.2(d) (Register 84, No. 12).
2. New subsection (j) filed 8-24-88; operative 9-23-88 (Register 88, No. 37).
3. Amendment filed 4-16-90; operative 4-16-90 (Register 90, No. 19).
4. New subsection (k) filed 5-11-90; operative 6-10-90 (Register 90, No. 26).
5. Repealer of subsection (e), subsection relettering, amendment of newly designated subsections (e) and (k), new subsections (l)-(o) and Note filed 6-23-95 as an emergency; operative 6-23-95 (Register 95, No. 25). A Certificate of Compliance must be transmitted to OAL by 10-21-95 or emergency language will be repealed by operation of law on the following day.
6. New subsection (p) and amendment of Note filed 8-17-95 as an emergency; operative 8-17-95 (Register 95, No. 33). A Certificate of Compliance must be transmitted to OAL by 12-15-95 or emergency language will be repealed by operation of law on the following day.
7. Certificate of Compliance as to 6-23-95 order including amendment of subsection (m) transmitted to OAL 10-20-95 and filed 12-6-95 (Register 95, No. 49).
8. Certificate of Compliance as to 8-17-95 order transmitted to OAL 12-15-95 and filed 1-25-96 (Register 96, No. 4).
9. Amendment of subsection (g) filed 4-29-96 as an emergency; operative 4-29-96 (Register 96, No. 18). A Certificate of Compliance must be transmitted to OAL by 8-27-96 or emergency language will be repealed by operation of law on the following day.
10. Amendment of subsection (c) and (d), new subsection (e) and subsection relettering, repealer of previously designated subsection (f), and amendment of subsections (g), (k) and (l) filed 7-26-96 as an emergency; operative 7-26-96 (Register 96, No. 30). A Certificate of Compliance must be transmitted to OAL by 11-25-96 or emergency language will be repealed by operation of law on the following day.
11. Certificate of Compliance as to 4-29-96 order transmitted to OAL 8-21-96 and filed 9-30-96 (Register 96, No. 40).
12. Editorial correction of subsection (p) (Register 97, No. 2).
13. Certificate of Compliance as to 7-26-96 order, including further amendment of subsection (g), transmitted to OAL 11-19-96 and filed 1-6-97 (Register 97, No. 2).
14. New subsections (q) and (r) and amendment of Note filed 4-23-97 as an emergency; operative 4-23-97 (Register 97, No. 17). A Certificate of Compliance must be transmitted to OAL by 8-21-97 or emergency language will be repealed by operation of law on the following day.
15. Certificate of Compliance as to 4-23-97 order, including new subsections (s)-(t) and further amendment of Note, transmitted to OAL 8-19-97 and filed 9-30-97 (Register 97, No. 40).
16. New subsections (u)-(x) and amendment of Note filed 10-30-98 as an emergency; operative 10-30-98 (Register 98, No. 44). A Certificate of Compliance must be transmitted to OAL by 3-1-99 or emergency language will be repealed by operation of law on the following day.
17. New subsections (ad)-(ag) and amendment of Note filed 12-3-98 as an emergency; operative 12-3-98 (Register 98, No. 49). A Certificate of Compliance must be transmitted to OAL by 4-2-99 or emergency language will be repealed by operation of law on the following day.
18. New subsections (u)-(x) and amendment of Note refiled 2-25-99 as an emergency; operative 3-1-99 (Register 99, No. 9). A Certificate of Compliance must be transmitted to OAL by 6-29-99 or emergency language will be repealed by operation of law on the following day.
19. New subsections (ad)-(ag) and amendment of Note refiled 3-30-99 as an emergency; operative 4-2-99 (Register 99, No. 14). A Certificate of Compliance must be transmitted to OAL by 8-2-99 or emergency language will be repealed by operation of law on the following day.
20. Certificate of Compliance as to 2-25-99 emergency, including amendment of subsection (x) and Note, transmitted to OAL 3-18-99 and filed 4-15-99; effective 5-1-99 (Register 99, No. 16).

21. New subsections (ad)-(ag) and amendment of Note refiled 7-26-99 as an emergency; operative 8-2-99 (Register 99, No. 31). A Certificate of Compliance must be transmitted to OAL by 11-30-99 or emergency language will be repealed by operation of law on the following day.
22. Certificate of Compliance as to 7-26-99 order, including further amendment of subsections (ad)-(ag) and Note, transmitted to OAL 11-18-99 and filed 1-3-2000 (Register 2000, No. 1).
23. Amendment of subsection (v) and repealer of subsection (w) filed 3-27-2000 as an emergency; operative 3-27-2000 (Register 2000, No. 13). A Certificate of Compliance must be transmitted to OAL by 7-25-2000 or emergency language will be repealed by operation of law on the following day.
24. Amendment of subsection (v), repealer of subsection (af), redesignation and amendment of subsections (x)-(ag) as subsections (w)-(z), new subsection (aa) and amendment of Note filed 6-26-2000 as an emergency; operative 7-1-2000 (Register 2000, No. 26). A Certificate of Compliance must be transmitted to OAL by 10-30-2000 or emergency language will be repealed by operation of law on the following day.
25. Amendment of subsection (v), repealer of subsection (af), redesignation and amendment of subsections (x)-(ag) as subsections (w)-(z), new subsection (aa) and amendment of Note refiled 10-30-2000 as an emergency; operative 10-30-2000 (Register 2000, No. 44). A Certificate of Compliance must be transmitted to OAL by 2-27-2001 or emergency language will be repealed by operation of law on the following day.
26. Certificate of Compliance as to 10-30-2000 order, including further amendment of subsections (v)-(y), new subsection (z), subsection relettering, and amendment of newly designated subsection (bb), transmitted to OAL 2-9-2001 and filed 3-27-2001 (Register 2001, No. 13).
27. Amendment of subsection (g), new subsection (t), subsection relettering and amendment of Note filed 3-3-2003; operative 4-2-2003 (Register 2003, No. 10).
28. Amendment of subsection (q), repealer and new subsections (r) and (s), new subsection (u), repealer of former subsection (v) and subsection relettering filed 4-28-2003; operative 5-28-2003 (Register 2003, No. 18).
29. Editorial correction restoring inadvertently omitted subsection (h) (Register 2006, No. 19).
30. Amendment of subsections (c)-(g), (i)-(j), (q)-(v) and (bb)-(cc) filed 5-30-2006; operative 6-29-2006 (Register 2006, No. 22).
31. Change without regulatory effect repealing and adopting new section filed 5-19-2010 pursuant to section 100, title 1, California Code of Regulations (Register 2010, No. 21).
32. Amendment filed 11-1-2011; operative 11-1-2011 pursuant to Government Code section 11343.4 (Register 2011, No. 44).
33. New definitions of "Repair-Only station," "Smog Check Inspector" and "Smog Check Repair Technician," amendment of definition of "Smog check technician" and repealer of definition of "Supervising technician" filed 2-1-2012; operative 2-1-2012 pursuant to Government Code section 11343.4 (Register 2012, No. 5).
34. New definitions of "BAR-97 Emissions Inspection System" and "OBD Inspection System," amendment of definitions of "Vehicle Inspection Report" and "Gear Shift Incident" and repealer of definitions of "Emissions Inspection System" filed 5-2-2013; operative 7-1-2013 (Register 2013, No. 18).
35. New definitions of "Alternative fuel retrofit system," "Engine change" and "Smog Check Referee" filed 5-17-2013; operative 7-1-2013 (Register 2013, No. 20).

**§ 3340.4. Smog Check Referee Services.**

(a) Referee services include, but are not limited to, the following:

- (1) The issuance of repair cost waivers and economic hardship extensions pursuant to Sections 44017 and 44017.1 of the Health and Safety Code.
- (2) The inspection of a vehicle in which the vehicle owner disputes the results of a previous smog check inspection and is seeking an independent evaluation.
- (3) The inspection of vehicular exhaust systems in accordance with Section 27150.2 of the Vehicle Code.
- (4) Inspection of vehicles equipped with engine or emission control configurations that do not match an original equipment manufacturers' United States Environmental Protection Agency or California Air Resources Board emission control certification standard. These vehicles include, but are not limited to, the following:



(A) Vehicles equipped with an engine change as defined in Section 3340.1.

(B) Direct import vehicle as defined in Section 39024.6 of the Health and Safety Code.

(C) Vehicles equipped with an alternative fuel retrofit system as defined in Section 3340.1.

(D) Specially constructed vehicles, including vehicles covered by the provisions described in Section 44017.4 of the Health and Safety Code.

(5) The inspection of a vehicle in which the physical or operational design or the vehicle's condition presents unusual inspection circumstances and/or inspection incompatibilities.

(6) The inspection of a vehicle in which a law enforcement agency has requested a referee inspection.

(7) Issuance of a limited parts exemption.

(8) The inspection of a government vehicle that is exempt from annual registration renewal, or is part of a fleet that is licensed pursuant to the provisions of Section 44020 of the Health and Safety Code.

(9) The inspection of vehicles in which the bureau has requested a referee inspection.

(b) As applicable, the referee shall affix a tamper resistant label to the vehicle. At a minimum, the label shall identify the engine and emission control systems requirements applicable to the vehicle in which the label is installed. Once a label is affixed, a vehicle with an engine change, a direct import vehicle, a vehicle with an alternative fuel retrofit system, or a specially constructed vehicle, excluding vehicles registered pursuant to Section 9565 of the Vehicle Code, may have subsequent smog check inspections performed at a licensed Smog Check station.

**AUTHORITY:**

**Note:** Authority cited: Sections 44014, 44015 and 44036, Health and Safety Code; and Section 9882, Business and Professions Code. Reference: Sections 44017, 44017.1, 44017.4, 44020 and 44036, Health and Safety Code; and Sections 9565 and 27150.2, Vehicle Code.

**HISTORY**

1. New section filed 5-17-2013; operative 7-1-2013 (Register 2013, No. 20).

**§ 3340.5. Vehicles Exempt from Inspections.**

(a) In addition to the vehicles exempted from the program by section 44011 of the Health and Safety Code, the following vehicles are exempted:

(1) any two cylinder vehicle.

(2) any vehicle powered exclusively by electricity.

(3) any two-cycle powered vehicle.

(4) any vehicle powered by diesel fuel until December 31, 2009.

(b) Vehicles powered by liquid petroleum gas or liquid natural gas are not exempt from the program.

(c) On and after January 1, 2010, 1998 model year and newer diesel-powered vehicles, with a gross vehicle weight rating up to and including 14,000 pounds, are not exempt from the program.

**AUTHORITY:**

**Note:** Authority cited: Sections 44002 and 44011, Health and Safety Code; and Section 9882, Business and Professions Code. Reference: Section 44011, Health and Safety Code.

**HISTORY**

1. New subsection (c) filed 3-28-86; effective thirtieth day thereafter (Register 86, No. 13).

2. Amendment filed 4-16-90; operative 4-16-90 (Register 90, No. 19).

3. Amendment of subsection (a)(2) and new subsections (a)(4) and (c) filed 12-16-2009; operative 12-16-2009 pursuant to Government Code section 11343.4 (Register 2009, No. 51).

**§ 3340.6. Vehicles Subject to Inspection upon Change of Ownership and Initial Registration in California.**

This program shall not replace any requirements contained in Sections 4000.1 and 4000.2 of the Vehicle Code for inspection upon change of ownership or initial registration in California.

**AUTHORITY:**

**Note:** Authority cited: Section 44002, Health and Safety Code; and sections 4000.1 and 4000.2, Vehicle Code. Reference: Sections 44005 and 44011, Health and Safety Code.

**HISTORY**

1. Editorial correction of printing error inadvertently omitting Authority and Reference (Register 91, No. 6).

**§ 3340.7. Fee for Inspection at State-Contracted Test-Only Facility.**

(a) The fee for an inspection at a test-only facility operating under the contract in existence on the effective date of this section shall be as negotiated with the department, and shall not exceed the department's actual cost of the test-only service. This fee shall remain operative in all regions of the state until implementation of subsection (b). Thereafter, the inspection fees shall be as provided in subsection (b).

(b) Upon commencement of testing by a contractor pursuant to an amended contract, or a new contract developed in the competitive bidding process, the fee for inspection at test-only facilities operated by the contractor shall be the fee as negotiated with the department.

(c) The department shall publish notice of each negotiated inspection fee, initially and as it may subsequently be modified, in one or more newspapers of general circulation in each region of the state in which the contractor's test-only facilities are to charge the fee. The department may also publish such notice in the California Regulatory Notice Register.

**AUTHORITY:**

**Note:** Authority cited: Section 44002, Health and Safety Code. Reference: Sections 44014.5 and 44015, Health and Safety Code.

**HISTORY**

1. New section filed 8-17-95 as an emergency; operative 8-17-95 (Register 95, No. 33). A Certificate of Compliance must be transmitted to OAL by 12-15-95 or emergency language will be repealed by operation of law on the following day.

2. Editorial correction of subsection (b) (Register 96, No. 4).

3. Certificate of Compliance as to 8-17-95 order transmitted to OAL 12-15-95 and filed 1-25-96 (Register 96, No. 4).

**§ 3340.8. Economic Hardship Extension.**

**AUTHORITY:**

**Note:** Authority cited: Sections 44002, 44015.3 and 44060, Health and Safety Code; and Section 9882, Business and Professions Code. Reference: Sections 44014.5, 44015, 44017, 44060 and 44062.1, Health and Safety Code; and Section 11519, Vehicle Code.

**HISTORY**

1. New section filed 11-20-95 as an emergency; operative 11-20-95 (Register 95, No. 47). A Certificate of Compliance must be transmitted to OAL by 3-19-96 or emergency language will be repealed by operation of law on the following day.
2. Editorial correction of subsection (a) (Register 96, No. 14).
3. Certificate of Compliance as to 11-20-95 order, including amendment of subsection (e), transmitted to OAL 3-8-96 and filed 4-5-96 (Register 96, No. 14).
4. Repealer filed 10-30-98 as an emergency; operative 10-30-98 (Register 98, No. 44). A Certificate of Compliance must be transmitted to OAL by 3-1-99 or emergency language will be repealed by operation of law on the following day.
5. Repealer refiled 2-25-99 as an emergency; operative 3-1-99 (Register 99, No. 9). A Certificate of Compliance must be transmitted to OAL by 6-29-99 or emergency language will be repealed by operation of law on the following day.
6. Certificate of Compliance as to 2-25-99 emergency transmitted to OAL 3-18-99 and filed 4-15-99; effective 5-1-99 (Register 99, No. 16).

**§ 3340.9. Repair Assistance Program.****AUTHORITY:**

**Note:** Authority cited: Sections 44001.5, 44002 and 44095, Health and Safety Code. Reference: Sections 44014.7, 44015, 44017, 44017.1, 44020, 44062.1, 44092, 44093, 44094 and 44095, Health and Safety Code.

**HISTORY**

1. New section and Form RAP-APP filed 10-30-98 as an emergency; operative 10-30-98 (Register 98, No. 44). A Certificate of Compliance must be transmitted to OAL by 3-1-99 or emergency language will be repealed by operation of law on the following day.
2. New section and Form RAP-APP refiled 2-25-99 as an emergency; operative 3-1-99 (Register 99, No. 9). A Certificate of Compliance must be transmitted to OAL by 6-29-99 or emergency language will be repealed by operation of law on the following day.
3. Certificate of Compliance as to 2-25-99 emergency, including amendment of subsections (b)(2)-(3) and (b)(5)(A)-(B) and new version of form RAP-APP, transmitted to OAL 3-18-99 and filed 4-15-99; effective 5-1-99 (Register 99, No. 16).
4. Amendment of section heading, section and Note, and repealer and new forms filed 3-27-2000 as an emergency; operative 3-27-2000 (Register 2000, No. 13). A Certificate of Compliance must be transmitted to OAL by 7-25-2000 or emergency language will be repealed by operation of law on the following day.
5. Renumbering of former section 3340.9 (including Form RAP-APP) to section 3394.6 filed 6-26-2000 as an emergency; operative 7-1-2000 (Register 2000, No. 26). A Certificate of Compliance must be transmitted to OAL by 10-30-2000 or emergency language will be repealed by operation of law on the following day.
6. Renumbering of former section 3340.9 (including Form RAP-APP) to section 3394.6 refiled 10-30-2000 as an emergency; operative 10-30-2000 (Register 2000, No. 44). A Certificate of Compliance must be transmitted to OAL by 2-27-2001 or emergency language will be repealed by operation of law on the following day.
7. Certificate of Compliance as to 10-30-2000 order transmitted to OAL 2-9-2001 and filed 3-27-2001 (Register 2001, No. 13).

**§ 3340.10. Licensing of Smog Check Stations.**

A registered automotive repair dealer may be licensed as a smog check station in accordance with the following:

- (a) Application. An applicant for an initial or renewal license shall submit an application to the bureau on form R-12 (01/11) "Application for Smog Check Station License," which is hereby incorporated by reference, along with the fee required in subsection (b).
- (b) Fees. Fees are established as follows:
  - (1) Initial license fee—\$100.00.
  - (2) Renewal license fee if submitted on or before the date of license expiration—\$100.00.
  - (3) Delinquency fee if a renewal license fee is submitted after the date of license expiration—\$50.00, which shall be assessed in addition to the \$100.00 renewal license fee.

(c) Term of License. A station license shall expire one year from the last day of the month in which the license was issued unless renewed, suspended, rescinded, or terminated by operation of law. The bureau may advance the expiration date to correspond with the automotive repair dealer's registration expiration date. A licensee whose license has expired shall immediately cease to inspect, test, diagnose or repair vehicles or issue certificates as part of the smog check program.

(d) Inspection. An inspection of the applicant's facility shall be made by a representative of the bureau. A license may be issued only for an applicant that meets the qualifications prescribed in this article.

(e) Replacement License. In determining whether a fee is required for a replacement license, the definitions given in section 3306(c)(1) and (2) of this chapter shall apply.

(1) In the event of a change of name or address of a licensee, a new application shall be submitted to the bureau and no fee will be required.

(2) In the event of a change of ownership of a licensed business, a new application and a license fee of \$100.00 shall be submitted to the bureau.

(3) In the event a license is lost, destroyed, or mutilated, application shall be made to the bureau for a duplicate license. The person to whom the license was issued shall furnish satisfactory proof of licensure. Upon receipt of application, the bureau shall issue a duplicate license for the unexpired term of the license. Any lost license that is later found shall be returned to the bureau.

(f) No person shall operate a smog check station unless a license to do so has been issued by the department.

**AUTHORITY:**

**Note:** Authority cited: Sections 44002 and 44034, Health and Safety Code; and Sections 163.5 and 9882, Business and Professions Code. Reference: Sections 44030, 44033 and 44034, Health and Safety Code.

**HISTORY**

1. Amendment of subsections (b) and (e)(2) filed 6-21-89; operative 6-21-89 (Register 89, No. 25).
2. Amendment filed 4-16-90; operative 4-16-90 (Register 90, No. 19).
3. Amendment of subsections (a) and (c) filed 7-26-96 as an emergency; operative 7-26-96 (Register 96, No. 30). A Certificate of Compliance must be transmitted to OAL by 11-25-96 or emergency language will be repealed by operation of law on the following day.
4. Certificate of Compliance as to 7-26-96 order, including further amendment of subsection (c), transmitted to OAL 11-19-96 and filed 1-6-97 (Register 97, No. 2).
5. Amendment of form R-12, *Application for Smog Check Station License* (incorporated by reference), amendment of subsection (a) and repealer of form 79-4 filed 2-1-2012; operative 2-1-2012 pursuant to Government Code section 11343.4 (Register 2012, No. 5).

**§ 3340.15. General Requirements for Smog Check Stations.**

A smog check station shall meet the following requirements for licensure and shall comply with these requirements at all times while licensed.

(a) The testing and repairing of vehicles shall be performed only in a work area of the station that has been approved by the bureau during the licensing inspection. Other work may be performed in the approved area, as desired. Except for heavy-duty vehicles, the work area shall be within a building and shall be large enough to accommodate the type of vehicle being serviced. In the case of the testing and repair of heavy-duty vehicles the work area need not be in a building, but the emissions

inspection system used at the station may only be used within a building. The work area shall be kept clean and orderly.

(b) A licensed inspector and/or repair technician shall be present during all hours the station is open for the business. Testing and/or repairing of vehicles pursuant to the Smog Check Program shall be performed by a licensed inspector and/or repair technician, consistent with their license classification.

(c) The station, inspector, and/or repair technician licenses shall be posted prominently under glass or other transparent material in an area frequented by customers.

(d) The station shall post conspicuously in an area frequented by customers a list of price ranges for the specific activities for which it is licensed. The posted prices shall include the price charged by the station for inspections, and, if a separate price is charged for reinspections, the reinspection price. The station shall also post the inspection prices for vans and/or heavy-duty vehicles if those prices differ from the passenger car inspection price. If the station imposes an hourly labor charge for repairs, the hourly labor rate shall be posted. The price of issuance of a certificate of compliance or noncompliance charged by the bureau shall be posted separately from the price of the inspection and of the reinspection, if any.

(e) The station shall make, keep secure, and have available for inspection on request of the bureau, or its representative, legible records showing the station's transactions as a licensee for a period of not less than three years after completion of any transaction to which the records refer. All records shall be open for reasonable inspection and/or reproduction by the bureau or its representative. Station records required to be maintained shall include copies of:

(1) All certificates of compliance and certificates of noncompliance in stock and/or issued,

(2) Repair orders relating to the inspection and repair activities, and

(3) Vehicle inspection reports generated either manually or by the emissions inspection system.

The above listed station records shall be maintained in such a manner that the records for each transaction are kept together, so as to facilitate access to those records by the bureau or its representative. In this regard, the second copy of an issued certificate shall be attached to the final invoice record.

(f) A smog check station shall be open and available to the general public for Smog Check Program services.

(g) A smog check station shall afford the bureau or its representative reasonable access during normal business hours to the station for the bureau's quality assurance efforts to evaluate the effectiveness of tests and/or repairs made to vehicles subject to the Smog Check Program.

(h) A licensed smog check station shall not sublet inspections or repairs required as part of the Smog Check Program, except for the following:

(1) Repairs of a vehicle's exhaust system which are normally performed by muffler shops, provided that the malfunction has been previously diagnosed by the spe-

cific smog check station originally authorized by the customer to perform repairs to the vehicle.

(2) Repairs of those individual components that have been previously diagnosed as being defective and that have been removed by the specific smog check station originally authorized by the customer to perform repairs to the vehicle.

(3) Repairs of diesel-powered vehicles provided the specific smog check station has obtained authorization from the customer to sublet repairs to the vehicle.

(4) Repairs to a vehicle's transmission provided the specific smog check station has obtained authorization from the customer to sublet repairs to the vehicle.

(5) Corrections to the vehicle's on-board computer systems' software provided that the malfunction has been previously diagnosed by the specific smog check station originally authorized by the customer to perform repairs to the vehicle.

(i) With respect to the sublet of repairs, the smog check station originally authorized by the customer to perform the repairs shall be responsible for any repair in the same manner as if station or its employees had done the repair.

#### AUTHORITY:

**Note:** Authority cited: Section 44002 and 44030, Health and Safety Code; and Section 9882 and 9884.9(b), Business and Professions Code. Reference: Sections 44014, 44030, 44032, 44033, 44036, 44037 and 44045.5, Health and Safety Code.

#### HISTORY:

1. Amendment of subsection (g) and repealer of subsection (h) filed 3-28-84; effective thirtieth day thereafter (Register 86, No. 13).
2. Amendment of subsection (d) filed 8-24-88; operative 9-23-88 (Register 88, No. 37).
3. Amendment filed 4-16-90; operative 4-16-90 (Register 90, No. 19).
4. Editorial correction of printing error in subsection (g) (Register 91, No. 6).
5. Amendment of subsection (e) filed 10-23-91; operative 11-22-91 (Register 92, No. 35).
6. Amendment of subsection (d) filed 8-18-92; operative 9-17-92 (Register 92, No. 37).
7. Repealer of subsection (b), subsection relettering, amendment of newly designated subsection (b), new subsection (c), and amendment of subsection (d) and Note filed 6-23-95 as an emergency; operative 6-23-95 (Register 95, No. 25). A Certificate of Compliance must be transmitted to OAL by 10-21-95 or emergency language will be repealed by operation of law on the following day.
8. Certificate of Compliance as to 6-23-95 order transmitted to OAL 10-20-95 and filed 12-6-95 (Register 95, No. 49).
9. New subsections (h)-(i)(2) and amendment of Note filed 4-15-97 as an emergency; operative 4-15-97 (Register 97, No. 16). A Certificate of Compliance must be transmitted to OAL by 8-13-97 or emergency language will be repealed by operation of law on the following day.
10. Editorial correction of History 9 (Register 97, No. 29).
11. Certificate of Compliance as to 4-15-97 order, including amendment of subsections (i)-(i)(2), transmitted to OAL 8-11-97 and filed 9-18-97 (Register 97, No. 38).
12. Amendment of subsection (a) filed 6-9-2003; operative 7-9-2003 (Register 2003, No. 24).
13. Change without regulatory effect amending section filed 10-11-2006 pursuant to section 100, title 1, California Code of Regulations (Register 2006, No. 41).
14. New subsections (i)(3)-(j) and amendment of Note filed 12-16-2009; operative 12-16-2009 pursuant to Government Code section 11343.4 (Register 2009, No. 51).
15. Amendment of subsection (b), repealer of subsection (c), subsection relettering and amendment of newly designated subsection (c) filed 2-1-2012; operative 2-1-2012 pursuant to Government Code section 11343.4 (Register 2012, No. 5).
16. Change without regulatory effect relettering subsections (e)-(j) to subsections (d)-(i) (there was previously no subsection (d)) filed 9-25-2012 pursuant to section 100, title 1, California Code of Regulations (Register 2012, No. 39).

**§ 3340.16. Test-Only Station Requirements.**

(a) A smog check test-only station shall meet the requirements for equipment and materials as specified in the Smog Check Manual referenced in section 3340.45.

(b) A smog check test-only station shall post conspicuously, in an area frequented by consumers, a notice to the effect that the station is licensed to test vehicles only, and cannot make any required diagnosis or repairs to a vehicle which has failed a smog check test.

(c) A smog check test-only station shall not engage in any automotive repair work.

(d) Effective through December 31, 2012, no smog check test-only station may refer a consumer to a particular automotive repair dealer or provider of smog check repair services. The test-only station shall make available to each customer a list prepared by the bureau of all smog check stations in that region licensed to make repairs of vehicular emission control systems, which shall include licensed stations certified under the Gold Shield program. Stations and technicians are prohibited from altering or revising the list supplied by the bureau. For the purpose of this subsection, the term “make available” means to grant access to.

(e) Effective January 1, 2013, no smog check test-only station may refer a consumer to a provider of repair services in which the owner of the test-only station has a financial interest.

(1) A financial interest includes any ownership in both automotive repair dealers, or any compensation for business referrals by either station including, but not limited to, direct payment, barter agreements, or “quid pro quo” arrangements.

(2) The test-only station shall provide consumers with instructions regarding how to access on the bureau’s website an updated list, compiled by region, of stations licensed to make repairs of vehicular emission control systems, including STAR test-and-repair stations.

(f) Effective through December 31, 2012, a smog check test-only station shall not have ownership in, corporate interest in, nor any other financial interest in a smog check test-and-repair station within a geographical radius of 50 statute miles of the test-only station.

(g) A smog check station owned either wholly or partially by the same party(s) that owns an automotive repair dealer that provides repair services, which is located adjacent to, or in the same business park, strip mall, or industrial complex as the first automotive repair dealer, shall not qualify as a test-only station.

**AUTHORITY:**

**Note:** Authority cited: Sections 44001.5, 44002, 44013 and 44036, Health and Safety Code; and Section 9882, Business and Professions Code. Reference: Sections 44010, 44012, 44013, 44014, 44014.5, 44015, 44017.1, 44033, 44036 and 44037.1, Health and Safety Code.

**HISTORY**

1. Amendment filed 4-16-90; operative 4-16-90 (Register 90, No. 19).  
2. New subsection (c) filed 5-11-90; operative 6-10-90 (Register 90, No. 26).

**3. Editorial correction of HISTORY 2. (Register 90, No. 45).**

4. Amendment of subsection (a)(5) filed 10-23-91; operative 11-22-91 (Register 92, No. 35).  
5. Amendment of section heading filed 8-18-92; operative 9-17-92 (Register 92, No. 37).  
6. Amendment of subsections (a)-(a)(5), new subsections (a)(9) and (b) and subsection relettering, and amendment of newly designated

subsection (c) filed 7-26-96 as an emergency; operative 7-26-96 (Register 96, No. 30). A Certificate of Compliance must be transmitted to OAL by 11-25-96 or emergency language will be repealed by operation of law on the following day.

7. Editorial correction of subsection (a)(3) (Register 97, No. 2).

8. Certificate of Compliance as to 7-26-96 order, including further amendment of subsection (a)(5) and repealer of subsection (a)(9), transmitted to OAL 11-19-96 and filed 1-6-97 (Register 97, No. 2).

9. Amendment of section heading and subsection (a)(6)(B), repealer and new subsection (d), new subsections (e) and (f) and amendment of Note filed 4-15-97 as an emergency; operative 4-15-97 (Register 97, No. 16). A Certificate of Compliance must be transmitted to OAL by 8-13-97 or emergency language will be repealed by operation of law on the following day.

10. Editorial correction of History 9 (Register 97, No. 29).

11. Editorial correction of subsection (f) (Register 97, No. 38).

12. Certificate of Compliance as to 4-15-97 order transmitted to OAL 8-11-97 and filed 9-18-97 (Register 97, No. 38).

13. New subsection (a)(9) filed 11-12-98 as an emergency; operative 11-12-98 (Register 98, No. 46). A Certificate of Compliance must be transmitted to OAL by 3-12-99 or emergency language will be repealed by operation of law on the following day.

14. Editorial correction repositioning subsection (a)(9) (Register 98, No. 47).

15. Certificate of Compliance as to 11-12-98 order transmitted to OAL 3-10-99 and filed 4-21-99 (Register 99, No. 17).

16. Amendment of subsections (a)(6)(A)-(E), (a)(7) and (b) filed 2-1-2001; operative 2-1-2001 pursuant to Government Code section 11343.4(c) (Register 2001, No. 5).

17. Amendment of subsections (a)(1), (a)(9) and (b) filed 2-15-2002 as an emergency; operative 2-15-2002 (Register 2002, No. 7). A Certificate of Compliance must be transmitted to OAL by 6-17-2002 or emergency language will be repealed by operation of law on the following day.

18. Certificate of Compliance as to 2-15-2002 order transmitted to OAL 6-13-2002 and filed 7-26-2002 (Register 2002, No. 30).

19. Amendment of subsections (a), (a)(1) and (b) filed 6-9-2003; operative 7-9-2003 (Register 2003, No. 24).

20. Editorial correction of subsection (e) (Register 2004, No. 22).

21. Amendment of section and Note filed 5-30-2006; operative 6-29-2006 (Register 2006, No. 22).

22. New subsection (a)(10) and amendment of Note filed 8-1-2007; operative 8-1-2007 pursuant to Government Code section 11343.4 (Register 2007, No. 31).

23. Repealer of subsections (a)(6)-(a)(6)(F), subsection renumbering and amendment of newly designated subsection (a)(9) filed 12-16-2009; operative 12-16-2009 pursuant to Government Code section 11343.4 (Register 2009, No. 51).

24. Amendment of subsections (b) and (e), new subsections (f)-(f)(2), subsection relettering, amendment of newly designated subsection (g) and new subsection (h) filed 11-1-2011; operative 11-1-2011 pursuant to Government Code section 11343.4 (Register 2011, No. 44).

25. Amendment filed 5-2-2013; operative 7-1-2013 (Register 2013, No. 18).

**§ 3340.16.4. Repair-Only Station Requirements.**

(a) A smog check repair-only station shall meet the requirements for equipment and materials as specified in the Smog Check Manual referenced in section 3340.45.

(b) A smog check repair-only station shall not accept a vehicle for repair if the station does not have the necessary equipment, tools, personnel, diagnostic and reference materials to repair that vehicle. The station may reject a vehicle if, as a matter of policy, the station:

(1) Does not repair certain types, makes or models of vehicles; or

(2) Does not repair certain types of vehicle inspection failures.

(c) A smog check repair-only station may not refer a consumer to a provider of smog check inspection or repair services in which the owner of the repair-only station has a financial interest.

(1) A financial interest includes any ownership in both automotive repair dealers, or any compensation for business referrals by either automotive repair dealer in-

cluding, but not limited to, direct payment, barter agreements, or “quid pro quo” arrangements.

(2) A repair-only station shall provide consumers with instructions regarding how to access on the bureau’s website an updated list, compiled by region, of STAR certified smog check stations.

**AUTHORITY:**

**Note:** Authority cited: Section 44002, Health and Safety Code; and Section 9882, Business and Professions Code. Reference: Sections 44010.5, 44012, 44014.5(e), 44014.7, 44030(b) and 44036(b), Health and Safety Code.

**HISTORY:**

1. New section filed 2-1-2012; operative 2-1-2012 pursuant to Government Code section 11343.4 (Register 2012, No. 5).
2. Amendment of section heading and section filed 5-2-2013; operative 7-1-2013 (Register 2013, No. 18).

**§ 3340.16.5. Test-and-Repair Station Requirements.**

(a) A smog check test-and-repair station shall meet the requirements for equipment and materials as specified in the Smog Check Manual referenced in section 3340.45.

(b) A smog check test-and-repair station that has accepted a vehicle for inspection shall disclose both orally and in writing on the written estimate provided pursuant to Section 9884.9 of the Business and Professions Code, before the initial inspection of the vehicle, if the vehicle is potentially affected by any of the following conditions:

(1) The station does not have adequate equipment, personnel, tools or reference materials to repair the vehicle, should the vehicle fail its inspection; or

(2) The station, as a matter of policy, does not repair certain types, makes or models of vehicles; or

(3) The station, as a matter of policy, does not repair certain types of vehicle inspection failures.

(c) Effective through December 31, 2012, a smog check test-and-repair station shall not refer a consumer to a particular test-only station for the testing and certification of a vehicle that has been directed to a test-only station for its biennial smog check pursuant to Section 44010.5 and 44014.7 of the Health and Safety Code. Test-and-repair stations shall make available to each customer that presents a test-only directed vehicle for initial testing a list prepared by the bureau of those smog check test-only stations in that region licensed to perform initial tests of, and to certify test-only directed vehicles. Stations and inspectors and/or repair technicians are prohibited from altering or revising the list supplied by the bureau. For the purpose of this subsection, the term “make available” means to grant access to.

(d) Effective January 1, 2013, a smog check test-and-repair station may not refer a consumer to a STAR certified station in which the owner of the test-and-repair station has a financial interest for the purpose of having the vehicle inspected pursuant to Sections 44010.5 and 44014.7 of the Health and Safety Code.

(1) A financial interest includes any ownership in both stations, or any compensation for business referrals by either station including, but not limited to, direct payment, barter agreements, or “quid pro quo” arrangements.

(2) Stations that are not STAR certified shall provide consumers with instructions regarding how to access on

the bureau’s website an updated list, compiled by region, of STAR certified smog check stations.

(e) Effective through December 31, 2012, a smog check test-and-repair station shall not have ownership in, corporate interest in, nor any other financial interest in a smog check test-only station within a geographical radius of 50 statute miles of the test-and-repair station.

**AUTHORITY:**

**Note:** Authority cited: Section 44002, Health and Safety Code; and Section 9882, Business and Professions Code. Reference: Sections 44012, 44014.5(e), 44030(b) and 44036(b), Health and Safety Code.

**HISTORY:**

1. Amendment filed 4-16-90; operative 4-16-90 (Register 90, No. 19).
2. New subsection (a)(8) and subsection renumbering filed 10-23-91; operative 11-22-91 (Register 92, No. 35).
3. Amendment of section heading and subsection (a) filed 8-18-92; operative 9-17-92 (Register 92, No. 37).
4. Repealer of subsection (c) and amendment of Note filed 4-29-96 as an emergency; operative 4-29-96 (Register 96, No. 18). A Certificate of Compliance must be transmitted to OAL by 8-27-96 or emergency language will be repealed by operation of law on the following day.
5. Amendment of subsections (a) and (a)(3), repealer of subsection (a) (5) and subsection renumbering, amendment of newly designated subsections (a)(6)-(a)(9), new subsections (a)(11)-(b)(2) and subsection relettering filed 7-26-96 as an emergency; operative 7-26-96 (Register 96, No. 30). A Certificate of Compliance must be transmitted to OAL by 11-25-96 or emergency language will be repealed by operation of law on the following day.
6. Certificate of Compliance as to 4-29-96 order transmitted to OAL 8-21-96 and filed 9-30-96 (Register 96, No. 40).
7. Editorial correction of subsection (a)(8) (Register 97, No. 2).
8. Certificate of Compliance as to 7-26-96 order, including further amendment of subsection (a), repealer of subsection (a)(13) and amendment of subsection (b)(2), transmitted to OAL 11-19-96 and filed 1-6-97 (Register 97, No. 2).
9. Amendment of section heading and subsections (a) and (c), and new subsection (d) filed 4-15-97 as an emergency; operative 4-15-97 (Register 97, No. 16). A Certificate of Compliance must be transmitted to OAL by 8-13-97 or emergency language will be repealed by operation of law on the following day.
10. Editorial correction of History 9 (Register 97, No. 29).
11. Certificate of Compliance as to 4-15-97 order transmitted to OAL 8-11-97 and filed 9-18-97 (Register 97, No. 38).
12. New subsections (a)(13) and (b)(3) filed 2-1-2001; operative 2-1-2001 pursuant to Government Code section 11343.4(c) (Register 2001, No. 5).
13. Amendment of subsections (a)-(a)(1), new subsections (a)(1)(A)-(B), amendment of subsection (b)(2) and amendment of Note filed 11-27-2001; operative 12-27-2001 (Register 2001, No. 48).
14. Amendment of subsection (b)(1) filed 2-15-2002 as an emergency; operative 2-15-2002 (Register 2002, No. 7). A Certificate of Compliance must be transmitted to OAL by 6-17-2002 or emergency language will be repealed by operation of law on the following day.
15. Certificate of Compliance as to 2-15-2002 order transmitted to OAL 6-13-2002 and filed 7-26-2002 (Register 2002, No. 30).
16. Amendment of section and Note filed 5-30-2006; operative 6-29-2006 (Register 2006, No. 22).
17. Amendment of subsections (b)(3) and (d), new subsections (e)-(e)(2), subsection relettering and amendment of newly designated subsection (f) filed 11-1-2011; operative 11-1-2011 pursuant to Government Code section 11343.4 (Register 2011, No. 44).
18. Amendment of subsection (a), repealer of subsections (a)(1)-(13) and (b)(2), subsection renumbering and amendment of subsection (d) and Note filed 2-1-2012; operative 2-1-2012 pursuant to Government Code section 11343.4 (Register 2012, No. 5).
19. Amendment of subsection (a), repealer of subsections (b)-(b)(2) and subsection relettering filed 5-2-2013; operative 7-1-2013 (Register 2013, No. 18).

**§ 3340.16.6. Requirement for Telephone Line.**

**AUTHORITY:**

**Note:** Authority cited: Sections 44002 and 44036(b), Health and Safety Code. Reference: Sections 44012 and 44036(b), Health and Safety Code.

**HISTORY**

1. New section filed 5-11-90; operative 6-10-90 (Register 90, No. 26).
2. Amendment filed 6-9-2003; operative 7-9-2003 (Register 2003, No. 24).
3. Repealer filed 5-30-2006; operative 6-29-2006 (Register 2006, No. 22).

**§ 3340.16.7. Test Equipment and Electronic Transmission Requirements.**

**AUTHORITY:**

**Note:** Authority cited: Section 44002, 44036 and 44037.1, Health and Safety Code. Reference: Sections 44012, 44036(b) and 44037.1, Health and Safety Code.

**HISTORY**

1. New section filed 4-29-96 as an emergency; operative 4-29-96 (Register 96, No. 18). A Certificate of Compliance must be transmitted to OAL by 8-27-96 or emergency language will be repealed by operation of law on the following day.
2. Amendment of subsection (a) and repealer and new subsection (b) filed 7-26-96 as an emergency; operative 7-26-96 (Register 96, No. 30). A Certificate of Compliance must be transmitted to OAL by 11-25-96 or emergency language will be repealed by operation of law on the following day.
3. Certificate of Compliance as to 4-29-96 order transmitted to OAL 8-21-96 and filed 9-30-96 (Register 96, No. 40).
4. Certificate of Compliance as to 7-26-96 order transmitted to OAL 11-19-96 and filed 1-6-97 (Register 97, No. 2).
5. Repealer filed 2-15-2002 as an emergency; operative 2-15-2002 (Register 2002, No. 7). A Certificate of Compliance must be transmitted to OAL by 6-17-2002 or emergency language will be repealed by operation of law on the following day.
6. Certificate of Compliance as to 2-15-2002 order transmitted to OAL 6-13-2002 and filed 7-26-2002 (Register 2002, No. 30).

**§ 3340.17. Test Equipment, Electronic Transmission, Maintenance and Calibration Requirements.**

(a) The BAR-97 Emissions Inspection System (EIS), shall meet the specifications contained in the BAR-97 Emissions Inspection System Specifications dated, May 1996, as revised through July 2009, which is hereby incorporated by reference. Vehicle data emission test results shall be transmitted to the bureau's centralized database in accordance with the procedures contained in these specifications, which include the form, manner and frequency of data transmittals. The EIS shall be maintained and calibrated in accordance with the bureau's BAR-97 Emissions Inspection System Specifications referenced in this subsection, and in accordance with the manufacturer's specifications. The EIS shall be calibrated only with bureau approved gases that are certified in accordance with section 3340.18 of this article. The EIS shall have the most current software and hardware updates required by the bureau.

(b) The OBD data acquisition device shall meet the specifications contained in the BAR OBD Inspection System Data Acquisition Device Specification dated, October 22, 2012, which is hereby incorporated by reference.

(c) Vehicle data and test results from the OBD Inspection System (OIS) shall be transmitted to the bureau's centralized database.

(d) Only bureau-authorized representatives or authorized manufacturer representatives shall have access to the following for service, inspection, or replacement: the locked areas of the EIS, the components or software located within the Low-Pressure Fuel Evaporative Test (LPFET), the components or software located within the OBD Data Acquisition Device.

(e) The LPFET equipment shall meet the specifications contained in the LPFET Specification dated January 2012, hereby incorporated by reference. Vehicle data emission test results shall be transmitted to the bureau's database in accordance with the procedures contained in the LPFET specification, which include the form, manner and frequency of data transmittals. The LPFET equipment shall be maintained and calibrated in accordance with the bureau's LPFET specification referenced in this subsection, and in accordance with the manufacturer's operating instructions. The LPFET equipment shall have the most current software and hardware updates required by the bureau.

(f) Any EIS, LPFET or OBD Inspection System (OIS) that the bureau finds does not comply with the hardware and software requirements and specifications established in this article will be disabled from communicating with the bureau's database and thereby preventing smog check inspections, and the transmittal of certificates of compliance to the Department of Motor Vehicles, until they are brought into compliance. When any non-compliant EIS, LPFET or OIS communicates with the database, the database will disable the ability of the EIS, LPFET or OIS to issue certificates of compliance and to perform Smog Check tests or inspections.

**AUTHORITY:**

**Note:** Authority cited: Sections 44002, 44036 and 44037.1, Health and Safety Code; and Section 9882, Business and Professions Code. Reference: Sections 44012, 44036 and 44037.1, Health and Safety Code.

**HISTORY**

1. Amendment filed 4-16-90; operative 4-16-90 (Register 90, No. 19).
2. Editorial correction of printing error restoring subsection (c) (Register 91, No. 6).
3. Amendment of subsections (a) and (c) filed 4-29-96 as an emergency; operative 4-29-96 (Register 96, No. 18). A Certificate of Compliance must be transmitted to OAL by 8-27-96 or emergency language will be repealed by operation of law on the following day.
4. Certificate of Compliance as to 4-29-96 order transmitted to OAL 8-21-96 and filed 9-30-96 (Register 96, No. 40).
5. Amendment of section heading, section and Note filed 2-15-2002 as an emergency; operative 2-15-2002 (Register 2002, No. 7). A Certificate of Compliance must be transmitted to OAL by 6-17-2002 or emergency language will be repealed by operation of law on the following day.
6. Certificate of Compliance as to 2-15-2002 order transmitted to OAL 6-13-2002 and filed 7-26-2002 (Register 2002, No. 30).
7. Redesignation and amendment of former subsection (a) as subsection (a)(1), new subsection (a)(2) and amendment of subsection (d) filed 6-9-2003; operative 7-9-2003 (Register 2003, No. 24).
8. Editorial correction of subsection (a)(2) (Register 2005, No. 44).
9. Amendment of section and Note filed 5-30-2006; operative 6-29-2006 (Register 2006, No. 22).
10. Amendment of subsections (b) and (g) filed 11-5-2009; operative 12-5-2009 (Register 2009, No. 45).
11. Amendment of subsections (a) and (b) filed 2-1-2012; operative 2-1-2012 pursuant to Government Code section 11343.4 (Register 2012, No. 5).
12. Amendment filed 5-2-2013; operative 7-1-2013 (Register 2013, No. 18).

**§ 3340.17.1. Decertification of Equipment Manufacturers.**

(a) If the bureau finds that a BAR-97 EIS or DAD manufacturer, hereinafter referred to as manufacturer, fails to furnish or install required software updates to the BAR-97 EIS or DAD, or to meet the specifications, standards, or requirements as provided in the BAR-97 Emissions Inspection System Specification or the BAR OBD Inspection System Data Acquisition Device Specification incorporated by reference in section

3340.17, the bureau may decertify the manufacturer's BAR-97 EIS or DAD and prevent the use of the equipment in the California Smog Check Program.

(b) If the bureau finds cause to decertify a manufacturer's BAR-97 EIS or DAD, the bureau shall file and serve a notice in writing or by electronic mail to the manufacturer(s). The notice shall contain a summary of the facts and allegations that form the cause or causes for decertification and may be given in any manner authorized by Business and Professions Code Section 124.

(c) If the bureau receives a written or electronic request for a hearing from the manufacturer within five (5) days from the date of service, a hearing shall be held as provided for as follows:

(1) The bureau shall hold a hearing within ten (10) days of the date on which the bureau received a timely request for a hearing and notify the manufacturer of the time and place of the hearing.

(2) The hearing shall be limited in scope to the time period, facts, and allegations specified in the notice prepared by the bureau.

(d) The manufacturer shall be notified of the determination by the chief, or the chief's designee, who shall issue a decision and notify the manufacturer within ten (10) days of the close of the hearing.

(e) The manufacturer may request an administrative hearing in accordance with Chapter 5 (commencing with Section 11500) of Part 1 of Division 3 of Title 2 of the Government Code to contest the decision of the chief or the chief's designee within 30 days of the date of the determination by the chief, or the chief's designee.

**AUTHORITY:**

**Note:** Authority cited: Section 44036, Health and Safety Code; and Section 124, Business and Professions Code. Reference: Sections 11340, 11370, 11500 and 11505, Government Code.

**HISTORY**

1. New section filed 5-2-2013; operative 7-1-2013 (Register 2013, No. 18).

**§ 3340.17.2. Citations and Informal Citation Conference.**

(a) Notwithstanding Health and Safety Code section 44036, the cited BAR-97 EIS or DAD manufacturer, hereinafter referred to as manufacturer, may request an informal conference to review the contents of the citation. A request for an informal conference shall be made in writing, within five (5) days from the date of service of the citation, to the chief or the chief's designee.

(b) The chief or the chief's designee shall schedule an informal conference with the cited manufacturer within sixty (60) days from the receipt of the request. At the conclusion of the informal conference, the chief or the chief's designee may affirm, modify, or dismiss the citation. The chief or the chief's designee shall state in writing the reasons for his or her action and transmit within ten (10) days of the informal conference, a copy of the findings and decision to the cited manufacturer. Unless an administrative hearing as provided for in Health and Safety Code section 44036 was requested in a timely manner, an informal conference decision that affirms the citation shall be deemed to be a final order with regard to the citation issued.

(c) If the citation, including any fine levied, is modified, the citation originally issued shall be considered

withdrawn and a new citation issued. If the cited manufacturer desires a hearing to contest the new citation, a request must be made in writing, within five (5) days of receipt of the informal conference decision, to the chief or the chief's designee. The hearing shall be held pursuant to Chapter 5 (commencing with Section 11500) of Part 1 of Division 3 of Title 2 of the Government Code. A cited manufacturer may not request an informal conference for a citation that has been modified following an informal conference.

(d) Any failure to comply with the final order for payment of a fine, or to pay the amount specified in any settlement agreement, is cause for decertification of the manufacturer.

**AUTHORITY:**

**Note:** Authority cited: Section 44036, Health and Safety Code; and Section 124, Business and Professions Code. Reference: Section 11340, 11370, 11500 and 11505, Government Code.

**HISTORY**

1. New section filed 5-2-2013; operative 7-1-2013 (Register 2013, No. 18).

**§ 3340.18. Certification of Emissions Inspection System Calibration Gases and Blenders of Gases.**

Emissions inspection system calibration gases used by smog check stations and gas blenders who provide such calibration gases shall be certified by the bureau in accordance with the requirements of the bureau's "Specifications and Certification Procedures for Calibration and Audit Gases Used in the California Emissions I/M Program" publication dated January 2012, as herein incorporated by reference.

**AUTHORITY:**

**Note:** Authority cited: Sections 44002 and 44036.5, Health and Safety Code. Reference: Section 44036.5, Health and Safety Code.

**HISTORY**

1. New section filed 9-26-90; operative 10-26-90 (Register 90, No. 44).
2. Editorial correction of History 1 (Register 95, No. 47).
3. Amendment of section heading and section filed 6-9-2003; operative 7-9-2003 (Register 2003, No. 24).
4. Change without regulatory effect amending section heading and section filed 10-11-2006 pursuant to section 100, title 1, California Code of Regulations (Register 2006, No. 41).
5. Amendment filed 5-2-2013; operative 7-1-2013 (Register 2013, No. 18).

**§ 3340.20. Acknowledgment and Waiver Requirement for Licensed Test-and-Repair Stations.**

**AUTHORITY:**

**Note:** Authority cited: Section 44002, Health and Safety Code. Reference: Section 44033(b) and (c), Health and Safety Code.

**HISTORY**

1. Repealer filed 8-24-88; operative 9-23-88 (Register 88, No. 37).

**§ 3340.22. Smog Check Station Signs.**

Each smog check test-only, repair-only, and test-and-repair station shall display an identifying sign that meets the following specifications:

(a) Dimensions. The sign shall be 24 inches wide and 30 inches high.

(b) Sign Material. The sign shall be made of 0.040 aluminum or steel.

(c) Content. Camera-ready design and content of the sign shall be supplied by the bureau.

**AUTHORITY:**

**Note:** Authority cited: Section 44002, Health and Safety Code. Reference: Section 44033(a), Health and Safety Code.

**HISTORY:**

1. Amendment filed 4-16-90; operative 4-16-90 (Register 90, No. 19).  
2. Amendment of first paragraph filed 2-1-2012; operative 2-1-2012 pursuant to Government Code section 11343.4 (Register 2012, No. 5).

**§ 3340.22.1. Smog Check Station Service Signs.**

(a) Separate sign requirements shall apply to the following types of stations which provide smog check program services:

(1) Smog check stations which only inspect and/or repair heavy-duty vehicles.

(2) Smog check stations which do not inspect and/or repair heavy-duty vehicles.

(3) Smog check stations that only inspect and/or repair vehicles powered by diesel engines or engines originating from diesel compression ignition designs.

(b) The service signs required by subdivision (a) shall be made of 0.040 aluminum or steel stock and shall be 24 inches wide and 8 inches high. Camera-ready design and content of required signs are available from the bureau upon request.

(c) Service signs shall be securely attached to the bottom of or immediately below the smog check station signs required by section 3340.22 of this article.

**AUTHORITY:**

**Note:** Authority cited: Section 44002, Health and Safety Code. Reference: Sections 44033(a) and 44045.5, Health and Safety Code.

**HISTORY:**

1. New section filed 4-16-90; operative 4-16-90 (Register 90, No. 19).  
2. Repealer of subsection (a)(2), subsection renumbering, and amendment of Note filed 6-23-95 as an emergency; operative 6-23-95 (Register 95, No. 25). A Certificate of Compliance must be transmitted to OAL by 10-21-95 or emergency language will be repealed by operation of law on the following day.  
3. Certificate of Compliance as to 6-23-95 order transmitted to OAL 10-20-95 and filed 12-6-95 (Register 95, No. 49).  
4. Amendment of subsection (a), new subsections (a)(4) and (a)(5), amendment of subsections (b) and (c) and repealer of Figures 2-5 filed 7-26-96 as an emergency; operative 7-26-96 (Register 96, No. 30). A Certificate of Compliance must be transmitted to OAL by 11-25-96 or emergency language will be repealed by operation of law on the following day.  
5. Editorial correction of section heading (Register 97, No. 2).  
6. Certificate of Compliance as to 7-26-96 order transmitted to OAL 11-19-96 and filed 1-6-97 (Register 97, No. 2).  
7. Repealer of subsections (a)(4)-(5) filed 2-1-2001; operative 2-1-2001 pursuant to Government Code section 11343.4(c) (Register 2001, No. 5).  
8. Repealer of subsection (a)(1), subsection renumbering, new subsection (a)(3) and amendment of subsection (c) filed 2-1-2012; operative 2-1-2012 pursuant to Government Code section 11343.4 (Register 2012, No. 5).

**§ 3340.22.2. Smog Check Station Repair Cost Limit Sign.**

(a) The sign required by Section 44017.3 of the Health and Safety Code shall be provided by the bureau and shall have the following dimensions and specifications.

(1) Sign shall be 22 inches wide and 16 inches high.

(2) Sign shall be in black typeface on white background.

(3) Sign wording and point size shall be as supplied by the bureau.

(4) Typeface shall be Bookman.

(b) If a sign no longer meets the outlined specifications or is no longer readily legible, it will be replaced by the bureau.

**AUTHORITY:**

**Note:** Authority cited: Sections 44002 and 44017.3, Health and Safety Code. Reference: Section 44017.3, Health and Safety Code.

**HISTORY:**

1. New section filed 10-23-91; operative 11-22-91 (Register 92, No. 35).  
2. Amendment of subsection (b) filed 8-18-92; operative 9-17-92 (Register 92, No. 37).  
3. Amendment of subsections (a)(3) and (b) filed 5-8-95 as an emergency; operative 5-8-95 (Register 95, No. 19). A Certificate of Compliance must be transmitted to OAL by 9-5-95 or emergency language will be repealed by operation of law on the following day.  
4. Certificate of Compliance as to 5-8-95 order transmitted to OAL 8-31-95 and filed 9-25-95 (Register 95, No. 39).  
5. Amendment of subsections (a)(1) and (a)(4) filed 2-1-2001; operative 2-1-2001 pursuant to Government Code section 11343.4(c) (Register 2001, No. 5).

**§ 3340.22.3. Replacement of Signs.**

The bureau may require the replacement of any sign mandated by section 3340.22, 3340.22.1 or 3340.22.2 of this chapter, if such sign fails to meet applicable specifications or is no longer readily legible.

**AUTHORITY:**

**Note:** Authority cited: Section 44002, Health and Safety Code. Reference: Sections 44017.3 and 44033(a), Health and Safety Code.

**HISTORY:**

1. New section filed 8-18-92; operative 9-17-92 (Register 92, No. 37).

**§ 3340.23. Licensed Smog Check Station That Ceases Operating As a Licensed Station.**

A smog check station shall cease performing the functions for which it has been licensed when it no longer has in its employ an inspector or repair technician, licensed for the appropriate category of vehicle being tested or repaired, or when its license has expired or has been surrendered, suspended, or revoked. Such station must dispose of materials related to its formerly licensed activity according to these provisions:

(a) Loss of Services of Licensed Inspector or Repair Technician. A licensed station that no longer has in its employ a smog check inspector or repair technician, licensed for the appropriate category of vehicle being tested or repaired, shall immediately remove or cover the; smog check station sign in accordance with subsection (b) of this section. If the station does not have in its employ, within 60 days, a smog check inspector or repair technician, licensed for the appropriate category of vehicle being tested or repaired, the station shall surrender its station license to the bureau and shall return to the bureau all unused certificates of compliance and noncompliance.

(b) Removal of Sign. A licensed station that is no longer authorized to perform the function for which it was licensed shall remove or cover the smog check station sign.

(c) Return of Certificates. When a station license has expired or has been surrendered, suspended or revoked, the station shall return to the bureau all unused certificates purchased by the station.



**AUTHORITY:**

**Note:** Authority cited: Section 44002, Health and Safety Code. Reference: Sections 44030(a) and (b), 44031, 44032, 44033 and 44045.5, Health and Safety Code.

**HISTORY**

1. Amendment filed 4-16-90; operative 4-16-90 (Register 90, No. 19).
2. Amendment of first paragraph, subsection (a) and Note filed 6-23-95 as an emergency; operative 6-23-95 (Register 95, No. 25). A Certificate of Compliance must be transmitted to OAL by 10-21-95 or emergency language will be repealed by operation of law on the following day.
3. Certificate of Compliance as to 6-23-95 order transmitted to OAL 10-20-95 and filed 12-6-95 (Register 95, No. 49).
4. Amendment of first paragraph and subsection (a) filed 2-1-2012; operative 2-1-2012 pursuant to Government Code section 11343.4 (Register 2012, No. 5).

**§ 3340.24. Suspension, Revocation, and Reinstatement of Licenses.**

(a) Any disciplinary or reinstatement proceeding under this article involving licensed stations, licensed technicians, or fleet owners licensed pursuant to section 44020 of the Health and Safety Code shall be conducted in accordance with chapter 5 (commencing with section 11500) of division 3, Title 2 of the Government Code.

(b) The bureau may suspend or revoke the license of or pursue other legal action against a licensee, if the licensee knowingly and willfully resists, delays, or obstructs any employee of the bureau or any employee of the quality assurance contractor of the bureau in carrying out the lawful performance of his or her duties.

(c) The bureau may suspend or revoke the license of or pursue other legal action against a licensee, if the licensee falsely or fraudulently issues or obtains a certificate of compliance or a certificate of noncompliance.

(d) The bureau may suspend or revoke the license of or pursue other legal action against a licensee that fails to complete retraining when required by the department, pursuant to section 44045.6 of the Health and Safety Code.

**AUTHORITY:**

**Note:** Authority cited: Sections 44002 and 44035, Health and Safety Code. Reference: Sections 44020, 44031.5, 44035, 44045.6, 44050 and 44072.2, Health and Safety Code; and Section 11500, et seq., Government Code.

**HISTORY**

1. Amendment filed 4-16-90; operative 4-16-90 (Register 90, No. 19).
2. Amendment of first paragraph, subsection (d) and NOTE filed 6-23-95 as an emergency; operative 6-23-95 (Register 95, No. 25). A Certificate of Compliance must be transmitted to OAL by 10-21-95 or emergency language will be repealed by operation of law on the following day.
3. Certificate of Compliance as to 6-23-95 order transmitted to OAL 10-20-95 and filed 12-6-95 (Register 95, No. 49).

**§ 3340.25. Licensing of Inspectors.**

**AUTHORITY:**

**Note:** Authority cited: Section 44002, Health and Safety Code; and 163.5, Business and Professions Code. Reference: Sections 44015, 44031 and 44031.5, Health and Safety Code.

**HISTORY**

1. Amendment of subsections (a), (e) and (f) filed 6-21-89; operative 6-21-89 pursuant to Government Code section 11346.2(d) (Register 89, No. 25).
2. Amendment filed 4-16-90; operative 4-16-90 (Register 90, No. 19).
3. Repealer filed 6-23-95 as an emergency; operative 6-23-95 (Register 95, No. 25). A Certificate of Compliance must be transmitted to OAL by 10-21-95 or emergency language will be repealed by operation of law on the following day.

4. Certificate of Compliance as to 6-23-95 order transmitted to OAL 10-20-95 and filed 12-6-95 (Register 95, No. 49).

**§ 3340.28. Licenses and Qualifications for Smog Check Inspectors and Repair Technicians.**

(a) An individual may qualify for the following Smog Check licenses:

(1) Smog Check Inspector. The Smog Check Inspector license allows an individual to inspect, and certify the emissions control systems on vehicles subject to the Smog Check Program in all areas of the state. The Smog Check Inspector license expires pursuant to the requirements in subsection (d) of section 3340.29 of this Article.

(2) Smog Check Repair Technician. The Smog Check Repair Technician license allows an individual to diagnose, adjust, and repair the emissions control systems on vehicles subject to the Smog Check Program at smog check stations in all areas of the state. The Smog Check Repair Technician license expires pursuant to the requirements in subsection (d) of section 3340.29 of this Article.

(b) Smog Check Inspector Qualifications.

The Smog Check Inspector license requires an examination. The qualifications to take the examination for the Smog Check Inspector license are:

(1) The applicant must provide proof, satisfactory to the bureau, of:

(A) The successful completion of bureau specified engine and emission control training within the last two years, and successful completion of the bureau's smog check training within the last two years; or

(B) At the bureau's discretion, successful completion of a competency assessment within the last two years, and successful completion of the bureau's smog check training within the last two years; or

(C) The applicant must provide proof, satisfactory to the bureau, of meeting the qualifications established in subsection (c)(1) and successful completion of the bureau's smog check training within the last two years.

(2) Update Training. The bureau may require update training as part of the requirements for license renewal. An applicant for renewal of a Smog Check Inspector license must provide proof, satisfactory to the bureau, of successful completion of bureau specified update training. At the bureau's discretion, a Smog Check Inspector may take a challenge test in lieu of taking the update training.

(c) Smog Check Repair Technician Qualifications. The Smog Check Repair Technician license requires an examination. The qualifications to take the examination for the Smog Check Repair Technician license are:

(1) The applicant must provide proof, satisfactory to the bureau, of:

(A) Possession of an Associate of Arts or Associate of Science degree or higher in Automotive Technology, from a state accredited or recognized college, public school, or trade school, and one year automotive repair experience in the engine performance area; or

(B) Possession of a certificate in automotive technology, from a state accredited or recognized college, public school, or trade school with a minimum of 720 hours course work that includes at least 280 hours course work

in the engine performance area, and one year of automotive repair experience in the engine performance area; or

(C) A minimum of two years of automotive repair experience in the engine performance area, and successful completion of bureau specified diagnostic and repair training within the last five years; or

(D) The applicant must provide proof, satisfactory to the bureau, of certification in the categories of Electrical/Electronic Systems (A6), Engine Performance (A8) and Advanced Engine Performance Specialist (L1) from the National Institute for Automotive Service Excellence, or other such established and nationally recognized automotive repair certification institution as determined by the bureau.

(2) Update Training. The bureau may require update training as part of the requirements for license renewal. An applicant for renewal of a license must provide proof, satisfactory to the bureau, of successful completion of a minimum of 16 hours of bureau specified update training. At the bureau's discretion, a repair technician may take a challenge test in lieu of taking the update training.

(d) A single license that allows the applicant to perform the services described in subsections (a)(1) and (2) may be issued to applicants who qualify for and pass the exam for both license types.

(e) Upon renewal of an unexpired Basic Area Technician license or an Advanced Emission Specialist Technician license issued prior to the effective date of this regulation, the licensee may apply to renew as a Smog Check Inspector, Smog Check Repair Technician, or both.

(f) An applicant for renewal of a Smog Check Repair Technician license who does not possess certification pursuant to subsection (c)(1)(D) of this section must provide proof, satisfactory to the bureau, of successful completion of the bureau specified diagnostic and repair training within the last five years.

**AUTHORITY:**

**Note:** Authority cited: Sections 44002, 44014 and 44045.5, Health and Safety Code; and Section 9882, Business and Professions Code. Reference: Section 44014, 44031.5(e) and 44045.5, Health and Safety Code.

**HISTORY:**

1. New section filed 6-23-95 as an emergency; operative 6-23-95 (Register 95, No. 25). A Certificate of Compliance must be transmitted to OAL by 10-21-95 or emergency language will be repealed by operation of law on the following day.
2. Certificate of Compliance as to 6-23-95 order transmitted to OAL 10-20-95 and filed 12-6-95 (Register 95, No. 49).
3. Amendment of section and Note filed 7-26-96 as an emergency; operative 7-26-96 (Register 96, No. 30). A Certificate of Compliance must be transmitted to OAL by 11-25-96 or emergency language will be repealed by operation of law on the following day.
4. Editorial correction of subsections (a)(2), (b)(2)(A), (b)(2)(C), (b)(3)(B), (b)(3)(C) and (b)(4)(A) (Register 97, No. 2).
5. Certificate of Compliance as to 7-26-96 order, including amendment of subsection (a)(2), repealer of subsections (a)(4) and (b)(3)-(b)(3)(A), subsection relettering and renumbering, and amendment of newly designated subsection (b)(4)(B), transmitted to OAL 11-19-96 and filed 1-6-97 (Register 97, No. 2).
6. Amendment filed 2-1-2001; operative 2-1-2001 pursuant to Government Code section 11343.4(c) (Register 2001, No. 5).
7. Amendment of section and Note filed 12-18-2008; operative 1-17-2009 (Register 2008, No. 51).
8. Amendment of section heading and section filed 2-1-2012; operative 2-1-2012 pursuant to Government Code section 11343.4 (Register 2012, No. 5).

**§ 3340.29. Licensing of Smog Check Inspectors and Repair Technicians.**

(a) An applicant for a license as an inspector or repair technician shall submit an application with appropriate documents to the bureau on form Inspector/Tech App 1A (12/2012) "Application for Initial Smog Check Inspector, and/or Smog Check Repair Technician License," which is hereby incorporated by reference, together with an application fee of \$20.00. If the applicant fails to include all required documentation, or complete all questions regarding the applicant's background, or otherwise fails to submit a complete original application the fee shall not be refunded and a license shall not be issued.

(b) An applicant for an inspector or repair technician license shall be subject to the following requirements:

(1) An applicant for an inspector or repair technician license shall pay an examination fee and successfully complete and pass the appropriate examination in order to receive a license.

(2) An applicant that receives a notice of qualification to take an examination, pursuant to section 3303.2 of this Article, shall take the appropriate examination within 90 days of receipt of notification of qualification to take the examination. A qualified applicant may attempt to pass the examination two times per application. After two attempts the applicant shall submit a new application to the bureau, pay an application fee of \$20, pay the examination fee and successfully complete and pass the appropriate examination.

(c) An initial application shall be subject to the review procedures specified in section 3303.2. of Article 1 of this Chapter.

(d) Initial license for a Smog Check Inspector or Smog Check Repair Technician shall expire on the last day of the licensee's birth month. If the initial license is issued more than six months prior to the licensee's birth month the license shall expire no less than 18 months from the issuance date. If the initial license is issued within six months of the licensee's birth month, the license shall expire no more than 30 months from the issuance date. License expiration dates are calculated from the date the department is notified that an applicant has passed the licensing examination. Subsequent renewal licenses will expire on the last day of the birth month, two years thereafter. The bureau may advance the expiration date of an inspector or repair technician license for the purpose of synchronizing license expiration dates. Withholding a license for enforcement purposes, or issuance of a temporary license due to family support obligations, does not change the expiration date as calculated above.

(e) To renew a license, the inspector or repair technician shall submit a renewal fee of \$20 and pay the examination fee, as applicable, and successfully complete and pass the appropriate examination, as applicable, prior to the expiration date of the license.

(f) The selection of an examination may be based on, but is not limited to, the applicant's professional or vocational certifications, education, experience, and/or disciplinary and citation history, at the bureau's discretion.

**AUTHORITY:**

**Note:** Authority cited: Sections 44002, 44013(b), 44016, 44031.5, 44034, 44034.1 and 44045.5, Health and Safety Code; and Sections 163.5 and

9882, Business and Professions Code. Reference: Sections 44012, 44014, 44015(a) and (b), 44030(a), 44031.5, 44032, 44034, 44034.1, 44035, 44045.5 and 44045.6, Health and Safety Code; and Section 1798.17, Civil Code.

#### HISTORY

1. New section filed 6-23-95 as an emergency; operative 6-23-95 (Register 95, No. 25). A Certificate of Compliance must be transmitted to OAL by 10-21-95 or emergency language will be repealed by operation of law on the following day.
2. Certificate of Compliance as to 6-23-95 order transmitted to OAL 10-20-95 and filed 12-6-95 (Register 95, No. 49).
3. Amendment of subsection (a), repealer of subsection (b)(2) and subsection renumbering, amendment of newly designated subsection (b) (2) and subsections (d), (e) and (f), repealer of subsections (f)(1) and (f)(2) and deletion of (f)(3) designator and amendment of formerly designated (f)(3) and Note filed 7-26-96 as an emergency; operative 7-26-96 (Register 96, No. 30). A Certificate of Compliance must be transmitted to OAL by 11-25-96 or emergency language will be repealed by operation of law on the following day.
4. Certificate of Compliance as to 7-26-96 order, including further amendment of subsections (d)-(f), transmitted to OAL 11-19-96 and filed 1-6-97 (Register 97, No. 2).
5. Amendment of subsections (a), (e) and (f) filed 2-1-2001; operative 2-1-2001 pursuant to Government Code section 11343.4(c) (Register 2001, No. 5).
6. Amendment of section and Note filed 12-18-2008; operative 1-17-2009 (Register 2008, No. 51).
7. Amendment of section heading and section filed 2-1-2012; operative 2-1-2012 pursuant to Government Code section 11343.4 (Register 2012, No. 5).
8. Change without regulatory effect amending subsection (a) and amending "Application for Initial Smog Check Inspector, and/or Smog Check Repair Technician License" (incorporated by reference) filed 2-27-2013 pursuant to section 100, title 1, California Code of Regulations (Register 2013, No. 9).

#### § 3340.30. General Requirements for Smog Check Inspectors and/or Repair Technicians.

A licensed smog check inspector and/or repair technician shall comply with the following requirements at all times while licensed:

- (a) Inspect, test and repair vehicles, as applicable, in accordance with section 44012 of the Health and Safety Code, section 44035 of the Health and Safety Code, and section 3340.42 of this article.
- (b) Maintain on file with the bureau a correct mailing address pursuant to section 3303.3 of Article 1 of this Chapter.
- (c) Notify the bureau in writing within two weeks of any change of employment.
- (d) Upon expiration of the inspector and/or repair technician license immediately cease to inspect, test, or repair failed vehicles, as applicable.

#### AUTHORITY:

**Note:** Authority cited: Sections 44002, 44013(b), 44016, 44031.5 and 44034, Health and Safety Code; and Section 163.5, Business and Professions Code. Reference: Sections 44012, 44015(a) and (b), 44030(a), 44031.5, 44032, 44034, 44034.1, 44035, 44045.5 and 44045.6, Health and Safety Code.

#### HISTORY

1. New subsection (h) filed 8-24-88; operative 9-23-88 (Register 88, No. 37).
2. Amendment filed 6-21-89; operative 6-21-89 pursuant to Government Code section 11346.2(d) (Register 89, No. 25).
3. Amendment filed 4-16-90; operative 4-16-90 (Register 90, No. 19).
4. Amendment of subsections (b) and (e) filed 5-11-90; operative 6-10-90 (Register 90, No. 26).
5. Amendment of subsections (b)(1)-(2) filed 8-18-92; operative 9-17-92 (Register 92, No. 37).
6. Editorial correction adding inadvertently omitted amendment of subsections (a), (c), (f) and Note filed 8-16-94 as an emergency; operative 8-16-94 (Register 95, No. 4). A Certificate of Compliance must be

transmitted to OAL 12-14-94 or emergency language will be repealed by operation of law on the following day.

7. Certificate of Compliance as to 8-16-94 order transmitted to OAL 12-12-94 and filed 1-24-95 (Register 95, No. 4).
8. Editorial correction of section heading (Register 95, No. 16).
9. Repealer and new section filed 6-23-95 as an emergency; operative 6-23-95 (Register 95, No. 25). A Certificate of Compliance must be transmitted to OAL by 10-21-95 or emergency language will be repealed by operation of law on the following day.
10. Certificate of Compliance as to 6-23-95 order transmitted to OAL 10-20-95 and filed 12-6-95 (Register 95, No. 49).
11. Amendment of section heading and section filed 2-1-2012; operative 2-1-2012 pursuant to Government Code section 11343.4 (Register 2012, No. 5).

#### § 3340.31. Retraining of Licensed Smog Check Inspectors and/or Repair Technicians.

(a) Licensed inspectors or repair technicians receiving citations pursuant to subdivision (b) of Section 44050 of the Health and Safety Code, or found lacking in skills pursuant to subdivision (b) of Section 44031.5 of the Health and Safety Code, or found lacking in skills pursuant to subdivision (c) of Section 44045.6 of the Health and Safety Code, shall be required to undergo retraining at institutions and by instructors certified by the bureau pursuant to Sections 44030.5 and 44045.6 of the Health and Safety Code.

(b) Failure by a licensed inspector or repair technician to complete retraining when required by the department shall be grounds for revocation or suspension of the license, pursuant to section 44045.6 of the Health and Safety Code.

#### AUTHORITY:

**Note:** Authority cited: Section 44002, Health and Safety Code. Reference: Sections 44030.5, 44031.5(b), 44045.6, 44050 and 44072.2, Health and Safety Code.

#### HISTORY

1. New section filed 6-21-89; operative 6-21-89 pursuant to Government Code Section 11346.2(d) (Register 89, No. 25).
2. Amendment of section heading, section and Note filed 6-23-95 as an emergency; operative 6-23-95 (Register 95, No. 25). A Certificate of Compliance must be transmitted to OAL by 10-21-95 or emergency language will be repealed by operation of law on the following day.
3. Certificate of Compliance as to 6-23-95 order transmitted to OAL 10-20-95 and filed 12-6-95 (Register 95, No. 49).
4. Amendment of section heading and section filed 2-1-2012; operative 2-1-2012 pursuant to Government Code section 11343.4 (Register 2012, No. 5).

#### § 3340.32. Standards for the Certification of Institutions Providing Retraining to Licensed Technicians or Prerequisite Training to Those Seeking to Become Licensed Technicians.

(a) An institution providing prerequisite training under subdivisions (a) and (b) of section 44045.6 of the Health and Safety Code to those seeking to become licensed technicians, or providing retraining to licensed technicians cited under the provisions of subdivision (c) of section 44045.6 of the Health and Safety Code, or providing retraining to licensed technicians cited under the provisions of subdivision (b) of section 44050 of the Health and Safety Code, or providing retraining to licensed technicians under the provisions of subdivision (b) of section 44031.5 of the Health and Safety Code must be certified by the bureau prior to providing that training or retraining.

(b) A school may be certified to instruct one or more of the following smog technician training courses:

(1) The Basic Smog Technician courses which consist of the Basic Clean Air Car Course, the Citation Retraining Course for Basic Area Technicians, the Bureau Training Program, and the Update Training for Basic Area Technicians.

(2) The Advanced Smog Technician courses which consist of the Advanced Clean Air Car Course, the BAR 97 Transition Course, the Citation Retraining Course for Advanced Emission Specialist Technicians, the Bureau Training Program, and the Update Training Course for Advanced Emission Specialist Technicians.

(c) To become certified, an institution shall submit an application to the bureau on form TS-1 (10-99), "Application to Become a BAR Certified Training Institution."

(d) An initial application shall be subject to the review procedures specified in Section 3303.2. of Article 1 of this Chapter.

(e) An applicant shall meet the following requirements:

(1) All institutions wishing to be certified to offer training to qualify an individual for a technician license shall provide satisfactory evidence of:

(A) Approval from the Department's Bureau for Private Postsecondary and Vocational Education, if applicable. That approval shall remain current at all times.

(B) Possession of current course materials.

(C) Lecture and shop facilities sufficient to adequately train all participating students.

(D) Instructors certified by the bureau pursuant to Section 3340.33 of this article to offer instruction.

(E) Having functional access to a bureau-designated web site and having an electronic mail address where the institution can receive electronic information from, and send electronic information to the bureau.

(2) An institution wishing to be certified to offer Basic Smog Technician courses shall have the following tools and materials in quantities sufficient to adequately train all participating students:

(A) An emissions inspection system as provided by and in accordance with, subsection (a) of Section 3340.17 of this article.

(B) An engine performance analyzer containing an electronic device capable of displaying and printing diagnostic information related to the engine ignition and fuel systems of the vehicle being tested.

(C) A tachometer/dwell meter.

(D) An ignition timing light which measures ignition advance.

(E) A hand vacuum pump, and a vacuum gauge.

(F) An ammeter capable of measuring amps and milliamps.

(G) A digital volt/ohm meter.

(H) A compression tester.

(I) Current emission control service manuals and systems application guides.

(J) Automotive computer diagnostic and repair manuals.

(K) Electronic component location manuals.

(L) Hand tools necessary to inspect, adjust, maintain, and repair vehicular ignition, fuel delivery, and emission control systems.

(M) Audio-visual equipment sufficient to adequately present the required course material.

(N) A diagnostic device capable of retrieving diagnostic trouble codes, interpreting codes, and displaying and storing data streams from the on-board computer systems of vehicles. Diagnostic data modules required to operate the device shall be kept updated to the current available calendar year. The device shall be On-Board Diagnostic II compliant, and shall have the Enhanced E/E Diagnostic Test Modes capabilities as noted in the Society of Automotive Engineer's document number J2190 dated June 1993.

(O) A fuel pressure gauge capable of measuring the higher pressures of fuel-injected vehicles.

(P) A Propane enrichment kit.

(Q) Fuel fillpipe restrictor dowel gauge meeting the following specifications:

1. Made of a non-sparking material meeting the standard for hardness of aluminum alloy No. 5052 as defined in Volume 02.02 of section 2 of the 1986 Annual Book of Standards published by the American Society for Testing and Materials;

2. Having a radiused test portion;

3. Having a test portion diameter not less than 0.9375 inches or more than 0.950 inches;

4. Having an overall length not less than 5 inches or more than 12 inches;

5. Having a handle no less than 1.25 inches in diameter, and no less than 4 inches in length; and

6. Constructed of solid bar stock or tubing with a minimum wall thickness of 3/16 of an inch.

(R) The currently available bureau manuals and bulletins.

(S) A minimum of one operational demonstration vehicle, or stationary engine per every four students attending a course must be available and must be used for demonstration and student laboratory assignments involving testing, diagnosis and repair procedures. The vehicle or stationary engine must be appropriate to the demonstration or laboratory assignment. At least one demonstration vehicle must be owned, rented or leased by the institution. Demonstration vehicles and stationary engines must be fully operational with computer-controlled systems.

(3) An institution wishing to be certified to offer Advanced Smog Technician courses shall, in addition to the equipment required by paragraph 2 of subsection (e) of this section, have the following equipment:

(A) An emissions inspection system in accordance with the bureau's emissions inspection system specifications referenced in subsection (b) of Section 3340.17 of this article.

(B) An evaporative emission control test system approved by the bureau for use in an enhanced program area.

(C) An electronic device capable of graphically displaying any electrical or electronic signal used by an automotive computer system. The device shall have the capability of displaying the electrical or electronic signal using a voltage and time scale that is adjustable. The de-

vice shall have the capability of capturing and displaying a high frequency abnormal signal, regardless of time per division setting, or screen refresh rate.

(f) Institutional certification by the bureau shall not exceed one-year. Institutions shall renew their certification electronically using form TS-1 (10-99); "Application To Become A Bureau Certified Training Institution" located at a bureau designated Internet web site.

(g) All institutions certified shall:

(1) Maintain adequate lecture and shop facilities, sufficient tools and materials, and current course materials.

(2) Identify in writing to all potential students the level of certification training the institution will provide and any limitations to this training applicable to obtaining a technician license. This written disclosure shall be presented to students no later than their first class meeting.

(3) Provide competent instruction to students, including lab exercises and hands-on work.

(4) Advise prospective students of the automotive mechanical experience and automotive mechanical course-work requirements at the time of application.

(5) Evaluate applications to verify that the applicant meets the applicable qualification requirements specified in subsection (b) of section 3340.28 of this article.

(6) Instruct a maximum of twenty-five students per instructor at any one time.

(7) Allow the bureau or authorized representative reasonable access during normal business hours to training records, equipment and facilities.

(8) Report to the bureau on form TS-5 (10-99), "Certified Institution's Training Record," the number of students receiving training or retraining courses prescribed by the bureau, the names of those students successfully completing training or retraining courses, and in the case of students taking retraining courses pursuant to section 3340.31 of this article, the names of those failing to complete such retraining courses. Reporting shall be performed electronically using form TS-5 (10-99); "Certified Institution's Training Record" located at a bureau designated Internet web site.

(9) Have available for students the current year editions of all required vehicle reference and repair manuals, in electronic or print media.

(10) Have available for students the current operating instructions for all training aids and automotive test equipment.

(11) Have available for students an adequate number and variety of training aids such as demonstration engines, carburetors, and emission control devices, in order to meet student training needs and to ensure proper understanding of the course content and laboratory assignments.

(h) Pursuant to section 44045.5 of the Health and Safety Code, an institution may be certified to instruct the Bureau Training Program to meet the prerequisite for licensure, as follows:

(1) The institution shall use training materials, course-work, and examinations developed by a bureau approved publisher.

(2) The institution shall obtain all training materials, course-work, and examinations from a bureau approved publisher. Failure to use training materials, course-work, or examinations developed by a bureau approved publisher may result in the disapproval of the training program or decertification of the institution.

(3) The institution's administration of examinations shall meet bureau standards, as outlined in the "Bureau Training Program Standards" (3-95), herein incorporated by reference, and meet or exceed all statutory requirements and federal and state standards regarding examination development. Failure to meet bureau standards, as outlined in the "Bureau Training Program Standards" (3-95), and meet or exceed all statutory requirements and federal and state standards regarding examination development, may result in the disapproval of the training program or decertification of the institution.

(4) The institution shall instruct the training program in accordance with the requirements outlined in the "Bureau Training Program Standards" (3-95). Failure to provide instruction that meets the requirements outlined in the "Bureau Training Program Standards" (3-95) may result in the disapproval of the training program or decertification of the institution.

(5) The bureau reserves the right to review and recommend changes to an institution's methods of instruction and/or administration of examinations. Failure to comply with the bureau's recommended changes to an institution's methods of instruction and/or administration of examinations may result in the disapproval of the training program or decertification of the institution.

#### AUTHORITY:

**Note:** Authority cited: Section 44002, Health and Safety Code. Reference: Sections 44030.5, 44031.5(b), 44045.6 and 44050, Health and Safety Code.

#### HISTORY

1. New section filed 6-21-89; operative 6-21-89 pursuant to Government Code section 11346.2(d) (Register 89, No. 25).
2. Editorial correction of History 1. (Register 91, No. 32).
3. New subsection (b)(3) and renumbering of following subsections filed 8-18-92; operative 9-17-92 (Register 92, No. 37).
4. Amendment of section heading, section and Note filed 6-23-95 as an emergency; operative 6-23-95 (Register 95, No. 25). A Certificate of Compliance must be transmitted to OAL by 10-21-95 or emergency language will be repealed by operation of law on the following day.
5. Certificate of Compliance as to 6-23-95 order including amendment of subsection (g)(3) transmitted to OAL 10-20-95 and filed 12-6-95 (Register 95, No. 49).
6. Amendment of section filed 7-26-96 as an emergency; operative 7-26-96 (Register 96, No. 30). A Certificate of Compliance must be transmitted to OAL by 11-25-96 or emergency language will be repealed by operation of law on the following day.
7. Editorial correction of subsections (b)(2), (e)(1)(F), (e)(3) and (e)(4) (Register 97, No. 2).
8. Certificate of Compliance as to 7-26-96 order, including repealer of subsection (b)(2), subsection renumbering, amendment of subsection (e)(1), repealer of subsections (e)(2)(N) and (e)(3)-(e)(3)(K), subsection relettering and renumbering, and amendment of subsection (h), transmitted to OAL 11-19-96 and filed 1-6-97 (Register 97, No. 2).
9. Amendment filed 2-1-2001; operative 2-1-2001 pursuant to Government Code section 11343.4(c) (Register 2001, No. 5).
10. Amendment of subsections (e)(2)(A) and (e)(3)(A) filed 2-15-2002 as an emergency; operative 2-15-2002 (Register 2002, No. 7). A Certificate of Compliance must be transmitted to OAL by 6-17-2002 or emergency language will be repealed by operation of law on the following day.
11. Certificate of Compliance as to 2-15-2002 order transmitted to OAL 6-13-2002 and filed 7-26-2002 (Register 2002, No. 30).

12. Amendment of subsection (e)(12) filed 6-9-2003; operative 7-9-2003 (Register 2003, No. 24).

13. Change without regulatory effect amending subsections (a)-(e)(1)(A), (e)(1)(D), (e)(2)-(e)(2)(A), (e)(2)(P), (e)(2)(Q)3.-4., (e)(3) and (e)(3)(A) filed 10-11-2006 pursuant to section 100, title 1, California Code of Regulations (Register 2006, No. 41).

**§ 3340.32.1. Standards for the Decertification and Recertification of Institutions Providing Retraining to Licensed Technicians or Prerequisite Training to Those Seeking to Become Licensed Technicians.**

(a) An application for certification may be denied or an institution may be decertified for the following reasons:

(1) Failure to comply with the provisions of Section 3340.32 of this article; or

(2) Misrepresentation of a material fact in obtaining or attempting to obtain certification as an institution; or

(3) Suspension or revocation of any bureau-issued license, registration, or qualification certificate held by the institution or by any owner, partner, officer, director, or manager of the institution, if the grounds for suspension or revocation are substantially related to the qualifications of the institution to provide bureau-prescribed courses of instruction; or

(4) Conviction of a crime or conduct which would be cause for denial of a license pursuant to Section 480 of the Business and Professions Code, or for suspension or revocation of a license pursuant to Section 490 of the Business and Professions Code.

(b) Institutions may be recertified as follows:

(1) Upon completion of an application for recertification; and

(2) After an on-site inspection of the institution has been accomplished by the bureau and a determination made by the bureau that the institution is again qualified to instruct students. In considering whether to make such determination, the bureau will evaluate the rehabilitation of the applicant based upon the criteria set forth in Section 3395 of this Chapter.

(c) Any decertification proceeding under this section shall be conducted in accordance with Chapter 5 (commencing with Section 11500) of Division 3, Title 2 of the Government Code.

**AUTHORITY:**

**Note:** Authority cited: Section 44002, Health and Safety Code. Reference: Sections 44030.5, 44045.6 and 44050, Health and Safety Code; Sections 480 and 490, Business and Professions Code; and Section 11500, et. seq., Government Code.

**HISTORY**

1. New section filed 6-21-89; operative 6-21-89 pursuant to Government Code Section 11346.2(d) (Register 89, No. 25).

2. Amendment of section heading and NOTE filed 6-23-95 as an emergency; operative 6-23-95 (Register 95, No. 25). A Certificate of Compliance must be transmitted to OAL by 10-21-95 or emergency language will be repealed by operation of law on the following day.

3. Certificate of Compliance as to 6-23-95 order transmitted to OAL 10-20-95 and filed 12-6-95 (Register 95, No. 49).

**§ 3340.33. Standards for the Certification of Basic and Advanced Instructors Providing Retraining to Intern, Basic Area, and Advanced Emission Specialist Licensed Technicians or Prerequisite Training to Those Seeking to Become Intern, Basic Area, or Advanced Emission Specialist Licensed Technicians.**

(a) There are the following instructor certification categories in the smog check program:

(1) **Basic Instructor.** An instructor providing Basic smog technician courses, or prerequisite training to those seeking to become Intern, or Basic Area licensed technicians, or providing retraining to Intern, or Basic Area technicians cited under the provisions of subdivision (b) of Section 44050 of the Health and Safety Code, or providing retraining to Intern, or Basic Area licensed technicians under provision of subdivision (b) of Section 44031.5 of the Health and Safety Code, or providing retraining to Intern, or Basic Area licensed technicians under Subdivision (c) of Section 44045.6 of the Health and Safety Code. A Basic instructor must have certification from the bureau prior to providing such training or retraining.

(2) **Advanced Instructor.** An instructor providing Advanced Smog Technician Courses, or prerequisite training to those seeking to become Intern, Basic Area, or Advanced Emission Specialist licensed technicians, or providing retraining to Intern, Basic Area, or Advanced Emission Specialist licensed technicians cited under the provisions of Subdivision (b) of Section 44050 of the Health and Safety Code, or providing retraining to Intern, Basic Area, or Advanced Emission Specialist licensed technicians under Subdivision (c) of Section 44045.6 of the Health and Safety Code. An Advanced Instructor must have certification from the bureau prior to providing such training or retraining.

(b) **Application.**

(1) To become certified as a Basic instructor, an individual shall submit an application to the bureau on form TS-2 (10-99), "Application To Become a Bureau Certified Basic Instructor."

(2) To become certified as an Advanced instructor, an individual shall submit an application to the bureau on form TS-3 (10-99) "Application To Become a Bureau Certified Advanced Instructor."

(c) **Initial Application Review.** An initial application shall be subject to the review procedures specified in section 3303.2. of Article 1 of this Chapter.

(d) **Applicant Criteria.**

(1) An applicant to be certified as a Basic Instructor shall:

(A) Be licensed by the bureau as an Advanced Emission Specialist Technician.

(B) Possess current certification from the National Institute for Automotive Service Excellence in the certification categories of Electrical/Electronic Systems (A6), Engine Performance (A8), and Advanced Engine Performance Specialist (L1).

(C) Meet at least one of the following criteria:

1. Possess a current credential recognized by the State Department of Education in the field of automotive technology; or

2. Meet the current California Community College eligibility requirements for a credential in the field of automotive technology; or

3. Possess an automotive-related degree, or credential, or other qualifying experience, which the bureau determines, upon the petition of the applicant, to be substantially equivalent to a California Community College's instructor's qualifications or credential or a credential recognized by the State Department of Education, in the field of automotive technology (more specifically described on bureau form TS-2 dated 10-99, "An Application To Become a Bureau Certified Basic Instructor," herein incorporated by reference).

(D) Have functional access to a bureau-designated web site and have an electronic mail address where the instructor can receive electronic information from, and send electronic information to the bureau.

(2) An applicant to be certified as an Advanced Instructor shall:

(A) Be currently certified as an Basic Instructor.

(B) Complete an Advanced Instructor training course prescribed by the bureau. Advanced Instructor training need not exceed 40 hours.

1. An individual submitting an application for initial certification as an instructor or renewal of certification as a instructor, may have the certification endorsed to instruct a gaseous fuels course by requesting the endorsement on the application and providing proof of qualification pursuant to subsection (e) of this section.

2. An individual may have an existing certification endorsed to instruct a gaseous fuels course by submitting a letter to the bureau requesting the endorsement be added to his/her existing certification and providing proof of qualification pursuant to subsection (e) of this section.

(e) Optional Endorsement for Gaseous Fuels. An optional endorsement to instruct a gaseous fuel course is available for a certified instructor with an Advanced Emission Specialist Technician license endorsed to test and repair vehicles powered by gaseous fuels, either solely or in combination with gasoline.

(f) Instructor certification by the bureau shall not exceed one-year. Instructors shall renew their certification electronically using a form TS-4 (10-99) "Bureau Certified Instructor Renewal Application" located at a bureau-designated web site.

(g) Certified Basic or Advanced instructors may be required to complete training on new automotive technology, as prescribed by the bureau, in order to instruct training courses. Failure to successfully complete bureau prescribed training may result in grounds for decertification or denial of certification, pursuant to section 3340.33.1 of this Article.

(h) Certification Renewal. To renew certification as a Basic or Advanced instructor, an individual shall be subject again to the requirements of subsections (b), (c), and (d) of this section.

**AUTHORITY:**

**Note:** Authority cited: Section 44002, Health and Safety Code. Reference: Sections 44030.5, 44031.5(b), 44045.6 and 44050, Health and Safety Code.

**HISTORY**

1. New section filed 6-21-89; operative 6-21-89 pursuant to Government Code Section 11346.2(d) (Register 89, No. 25).

2. Amendment of section heading, section and Note filed 6-23-95 as an emergency; operative 6-23-95 (Register 95, No. 25). A Certificate of Compliance must be transmitted to OAL by 10-21-95 or emergency language will be repealed by operation of law on the following day.

3. Certificate of Compliance as to 6-23-95 order transmitted to OAL 10-20-95 and filed 12-6-95 (Register 95, No. 49).

4. Amendment of subsection (b), repealer of subsections (d)-(d)(3) and subsection relettering, and amendment of newly designated subsections (d), (e)(1), (e)(2), (g) and (h) filed 7-26-96 as an emergency; operative 7-26-96 (Register 96, No. 30). A Certificate of Compliance must be transmitted to OAL by 11-25-96 or emergency language will be repealed by operation of law on the following day.

5. Editorial correction of subsection (g) (Register 97, No. 2).

6. Certificate of Compliance as to 7-26-96 order, including amendment of subsection (d)(3)(B)-(C), transmitted to OAL 11-19-96 and filed 1-6-97 (Register 97, No. 2).

7. Amendment of section heading and section filed 2-1-2001; operative 2-1-2001 pursuant to Government Code section 11343.4(c) (Register 2001, No. 5).

**§ 3340.33.1. Standards for the Decertification and Recertification of Instructors Providing Retraining to Licensed Technicians or Prerequisite Training to Those Seeking to Become Licensed Technicians.**

(a) An application for certification may be denied or an instructor may be decertified for the following reasons:

(1) Failure to comply with the provisions of Section 3340.33 of this article; or

(2) Misrepresentation of a material fact in obtaining certification as an instructor; or

(3) Failure to instruct students in a competent manner in accordance with the specifications of the bureau-prescribed course; or

(4) Suspension or revocation of any bureau-issued license, registration, or qualification certificate held by the instructor if the grounds for suspension or revocation are substantially related to the qualifications of the instructor to teach bureau-prescribed courses of instruction; or

(5) Conviction of a crime or conduct which would be cause for denial of a license pursuant to Section 480 of the Business and Professions Code, or for suspension or revocation of a license pursuant to Section 490 of the Business and Professions Code.

(b) Instructors may be recertified as follows:

(1) Upon completion of an application for recertification; and

(2) Upon determination by the bureau that the instructor is again qualified to instruct students. In considering whether to make such determination, the bureau will evaluate the rehabilitation of the applicant based upon the criteria set forth in Section 3395 of this Chapter.

(c) Any decertification proceeding under this section shall be conducted in accordance with Chapter 5 (commencing with Section 11500) of Division 3, Title 2 of the Government Code.

**AUTHORITY:**

**Note:** Authority cited: Section 44002, Health and Safety Code. Reference: Sections 44030.5, 44045.6 and 44050, Health and Safety Code; Sections 480 and 490, Business and Professions Code; and Section 11500, et. seq., Government Code.

**HISTORY**

1. New section filed 6-21-89; operative 6-21-89 (Register 89, No. 25).
2. Amendment of section heading and NOTE filed 6-23-95 as an emergency; operative 6-23-95 (Register 95, No. 25). A Certificate of Compliance must be transmitted to OAL by 10-21-95 or emergency language will be repealed by operation of law on the following day.
3. Certificate of Compliance as to 6-23-95 order transmitted to OAL 10-20-95 and filed 12-6-95 (Register 95, No. 49).

**§ 3340.34. Qualification Levels of Mechanics.****AUTHORITY:**

**Note:** Authority cited: Sections 44002 and 44014(c), Health and Safety Code. Reference: Section 44014(c), Health and Safety Code.

**HISTORY**

1. New section filed 4-16-90; operative 4-16-90 (Register 90, No. 19).
2. Repealer filed 6-23-95 as an emergency; operative 6-23-95 (Register 95, No. 25). A Certificate of Compliance must be transmitted to OAL by 10-21-95 or emergency language will be repealed by operation of law on the following day.
3. Certificate of Compliance as to 6-23-95 order transmitted to OAL 10-20-95 and filed 12-6-95 (Register 95, No. 49).

**§ 3340.35. A Certificate of Compliance, Noncompliance, Repair Cost Waiver or an Economic Hardship Extension.**

(a) A licensed station shall purchase certificates of compliance and noncompliance from the bureau or an authorized agent of the bureau only, and under the following terms and conditions:

(1) A certificate of compliance or noncompliance shall be purchased by a licensed station for a fee determined pursuant to section 3340.35.1 of these regulations; and

(2) Full payment is required at the time the certificates are ordered.

(b) A licensed station shall not sell or otherwise transfer unused certificates to another licensed station, to a new owner of the business, or to any person other than a customer whose vehicle has been inspected in accordance with the procedures specified in section 3340.42 of this article.

(c) A licensed station shall issue a certificate of compliance or noncompliance to the owner or operator of any vehicle that has been inspected in accordance with the procedures specified in section 3340.42 of this article and has all the required emission control equipment and devices installed and functioning correctly. The following conditions shall apply:

(1) Customers shall be charged the same price for certificates as that paid by the licensed station; and

(2) Sales tax shall not be assessed on the price of certificates.

(d) No person shall sell, issue, cause or permit to be issued any certificate purported to be a valid certificate of compliance or noncompliance unless duly licensed to do so.

(e) A repair cost waiver or an economic hardship extension shall be the same fee as a certificate of compliance or noncompliance.

**AUTHORITY:**

**Note:** Authority cited: Sections 44002 and 44060, Health and Safety Code. Reference: Sections 44010, 44011, 44014, 44015 and 44060, Health and Safety Code; and Sections 4000.2 and 4000.3, Vehicle Code.

**HISTORY**

1. Amendment of subsection (a) filed 3-28-86; designated effective 5-1-86 (Register 86, No. 13).

2. Amendment of subsections (a) and (b) filed 8-24-88; operative 9-23-88 (Register 88, No. 37).

3. Amendment of subsection (a)(1) filed 1-25-89; operative 3-1-89 (Register 89, No. 7).

4. Amendment filed 4-16-90; operative 4-16-90 (Register 90, No. 19).

5. Editorial correction of printing error in subsection (b) (Register 91, No. 6).

6. Amendment of subsection (a)(1) filed 12-18-91; operative 2-1-92 (Register 92, No. 10).

7. Amendment of subsection (a)(1) filed 5-8-95 as an emergency; operative 5-8-95 (Register 95, No. 19). A Certificate of Compliance must be transmitted to OAL by 9-5-95 or emergency language will be repealed by operation of law on the following day.

8. Repealer of subsection (d), subsection relettering, amendment of newly designated subsection (d), and amendment of Note filed 6-23-95 as an emergency; operative 6-23-95 (Register 95, No. 25). A Certificate of Compliance must be transmitted to OAL by 10-21-95 or emergency language will be repealed by operation of law on the following day.

9. Certificate of Compliance as to 5-8-95 order transmitted to OAL 8-31-95 and filed 9-25-95 (Register 95, No. 39).

10. Certificate of Compliance as to 6-23-95 order transmitted to OAL 10-20-95 and filed 12-6-95 (Register 95, No. 49).

11. Amendment of subsection (a)(1) and Note filed 2-11-97 as an emergency; operative 2-11-97 (Register 97, No. 7). A Certificate of Compliance must be transmitted to OAL by 6-11-97 or emergency language will be repealed by operation of law on the following day.

12. Certificate of Compliance as to 2-11-97 order transmitted to OAL 5-30-97 and filed 7-8-97 (Register 97, No. 28).

13. Amendment of subsection (a)(1) filed 2-26-98 as an emergency; operative 2-26-98 (Register 98, No. 9). A Certificate of Compliance must be transmitted to OAL by 6-26-98 or emergency language will be repealed by operation of law on the following day.

14. Amendment of subsection (a)(1) refiled 6-24-98 as an emergency; operative 6-25-98 (Register 98, No. 26). A Certificate of Compliance must be transmitted to OAL by 10-23-98 or emergency language will be repealed by operation of law on the following day.

15. Certificate of Compliance as to 6-24-98 order, including amendment of section heading, section and Note, transmitted to OAL 10-16-98 and filed 12-2-98 (Register 98, No. 49).

**§ 3340.35.1. A Certificate of Compliance, Noncompliance, Repair Cost Waiver or an Economic Hardship Extension Fee Calculation.**

The certificate of compliance, noncompliance, repair cost waiver or an economic hardship extension fee effective June 1998 through June 1999 is \$8.25; thereafter, for the purpose of establishing a fee for a certificate of compliance, noncompliance, repair cost waiver or an economic hardship extension, the bureau shall annually adjust the fee to reflect changes in the California Consumer Price Index for All Urban Consumers (CCPI), as published by the California Department of Industrial Relations, based on the regional data from the United States Department of Labor, Bureau of Labor Statistics. Each annual fee adjustment shall be made based on the change in the CCPI ending in June of the current year preceding the base year adjustment. The calculation of the fee increase shall be: CCPI for Current Period less CCPI for base year equals Index Point Change; Divided by the CCPI for base year equals Percent Change; Baseline fee of \$7.00 multiplied by Percent Change equal sum; Baseline fee plus sum equals new fee per certificate.

**AUTHORITY:**

**Note:** Authority cited: Sections 44002 and 44060, Health and Safety Code. Reference: Sections 44010, 44011 and 44060, Health and Safety Code.

**HISTORY**

1. New section filed 12-2-98; operative 12-2-98 (Register 98, No. 49).
2. Editorial correction (Register 2002, No. 23).



### § 3340.36. Clearing Enforcement Forms.

When a customer requests certification of a motor vehicle for correction of a violation noted on an enforcement form, the smog check station shall certify that the correction has been made. In conjunction with such certification, the licensed technician shall also issue a certificate of compliance or noncompliance, provided the vehicle passes the inspection/test procedure and all emission control systems are in compliance or meet bureau requirements.

#### AUTHORITY:

**Note:** Authority cited: Sections 44002, Health and Safety Code; and Section 9882, Business and Professions Code. Reference: Section 44045.5, Health and Safety Code; and Sections 27157, 27157.5, 27158 and 40616, Vehicle Code.

#### HISTORY

1. Amendment filed 4-16-90; operative 4-16-90 (Register 90, No. 19).
2. Amendment filed 6-23-95 as an emergency; operative 6-23-95 (Register 95, No. 25). A Certificate of Compliance must be transmitted to OAL by 10-21-95 or emergency language will be repealed by operation of law on the following day.
3. Certificate of Compliance as to 6-23-95 order transmitted to OAL 10-20-95 and filed 12-6-95 (Register 95, No. 49).
4. Amendment of section filed 7-26-96 as an emergency; operative 7-26-96 (Register 96, No. 30). A Certificate of Compliance must be transmitted to OAL by 11-25-96 or emergency language will be repealed by operation of law on the following day.
5. Certificate of Compliance as to 7-26-96 order transmitted to OAL 11-19-96 and filed 1-6-97 (Register 97, No. 2).

#### § 3340.36.1. Fee for Exhaust System Certificate of Compliance.

The fee for an exhaust system certificate of compliance issued pursuant to Section 27150.2 of the Vehicle Code shall be one hundred eight dollars (\$108).

#### AUTHORITY:

**Note:** Authority cited: Section 9882, Business and Professions Code; and Section 27150.2, Vehicle Code. Reference: Sections 27150, 27150.2 and 27151, Vehicle Code.

#### HISTORY

1. New section filed 4-12-2010; operative 5-12-2010 (Register 2010, No. 16).

### § 3340.37. Installation of Oxides of Nitrogen (NO<sub>x</sub>) Devices.

A licensed smog check station, except for a test-only station, may install a retrofit oxides of nitrogen (NO<sub>x</sub>) exhaust control device on a 1966 through 1970 model year vehicle.

#### AUTHORITY:

**Note:** Authority cited: Section 44002, Health and Safety Code; and Section 9882, Business and Professions Code. Reference: Sections 2814, 27158, 27158.5 and 40616, Vehicle Code; and Sections 43654, 43655, 43657 and 44045.5, Health and Safety Code.

#### HISTORY

1. Amendment of subsection (b) filed 7-12-85; effective upon filing pursuant to Government Code Section 11346.2(d) (Register 85, No. 28).
2. Amendment of subsection (b) filed 3-28-86; effective thirtieth day thereafter (Register 86, No. 13).
3. Amendment filed 4-16-90; operative 4-16-90 (Register 90, No. 19).
4. Amendment of subsections (d)-(e) and NOTE filed 6-23-95 as an emergency; operative 6-23-95 (Register 95, No. 25). A Certificate of Compliance must be transmitted to OAL by 10-21-95 or emergency language will be repealed by operation of law on the following day.
5. Certificate of Compliance as to 6-23-95 order transmitted to OAL 10-20-95 and filed 12-6-95 (Register 95, No. 49).

6. Amendment of section heading and repealer of subsection (a) designator and subsections (b)-(e) filed 4-15-96; operative 5-15-96 (Register 96, No. 16).

7. Amendment of section filed 7-26-96 as an emergency; operative 7-26-96 (Register 96, No. 30). A Certificate of Compliance must be transmitted to OAL by 11-25-96 or emergency language will be repealed by operation of law on the following day.

8. Certificate of Compliance as to 7-26-96 order transmitted to OAL 11-19-96 and filed 1-6-97 (Register 97, No. 2).

### § 3340.38. Vehicle Registration Amnesty Program. [Repealed]

#### AUTHORITY:

**Note:** Authority cited: Section 9882, Business and Professions Code. Reference: Sections 4750.1 and 9565, Vehicle Code; and Section 44012, Health and Safety Code.

#### HISTORY

1. New section filed 1-6-2012; operative 1-6-2012 pursuant to Government Code section 11343.4 (Register 2012, No. 1).
2. Change without regulatory effect repealing section filed 10-16-2013 pursuant to section 100, title 1, California Code of Regulations (Register 2013, No. 42).

### § 3340.41. Inspection, Test, and Repair Requirements.

(a) A licensed station shall give a copy of the test report printed from the emissions inspection system to the customer. The report shall be attached to the customer's invoice.

(b) No person shall enter into the emissions inspection system any access or qualification number other than as authorized by the bureau, nor in any way tamper with the emissions inspection system.

(c) No person shall enter into the emissions inspection system any vehicle identification information or emission control system identification data for any vehicle other than the one being tested. Nor shall any person knowingly enter into the emissions inspection system any false information about the vehicle being tested.

(d) The specifications and procedures required by Section 44016 of the Health and Safety Code shall be the vehicle manufacturer's recommended procedures for emission problem diagnosis and repair or the emission diagnosis and repair procedures found in industry-standard reference manuals and periodicals published by nationally recognized repair information providers. Smog check stations and smog check technicians shall, at a minimum, follow the applicable specifications and procedures when diagnosing defects or performing repairs for vehicles that fail a smog check test.

(e) Effective through December 31, 2012, a smog check station shall not perform an initial test, except for an official pre-test, on or issue a certificate of compliance to any vehicle that has been directed to a test-only station for its biennial smog check pursuant to Sections 44010.5 or 44014.7 of the Health and Safety Code, unless the station is licensed as a test-only station pursuant to subdivision (b) of Section 44014 of the Health and Safety Code. The reinspection and certification of a test-only directed vehicle that has failed an initial test at a test-only station and has undergone subsequent repairs to correct the cause of the failure, maybe performed by a test-only station, or by a test-and-repair station that performs those repairs and that is also certified as a Gold Shield station pursuant to Section 44014.2 of the Health and Safety Code and Article 10 (commencing with section 3392.1) of this chapter.

(f) Effective January 1, 2013, a smog check station may not perform an initial test, except for an official pre-test, on any vehicle or issue a certificate of compliance to any vehicle that has been directed to a STAR station for its biennial smog check pursuant to Sections 44010.5 or 44014.7 of the Health and Safety Code, unless the sta-

tion is certified as a STAR station pursuant to Sections 44014.2 or 44014.5 of the Health and Safety Code. The reinspection and certification of a directed vehicle that has failed an initial test at a STAR station and has undergone subsequent repairs to correct the cause of the failure shall be performed by a STAR station.

STATE OF CALIFORNIA - STATE AND CONSUMER SERVICES AGENCY

Gray Davis, Governor



BUREAU OF AUTOMOTIVE REPAIR
10240 SYSTEMS PARKWAY, SACRAMENTO, CA 95827
PHONE: (916) 255-3465



APPLICATION TO BECOME A BUREAU CERTIFIED TRAINING INSTITUTION

Check One:

- Input boxes for: New Institution Certification, Upgrading from a Basic to Advanced Institution, Renewal of Institution Certification, Institute Relocation

Please Print

Name of Institution:
Address of Instructional Facility (no P.O. Boxes):
City: County: Zip:
Phone Number: Ext. #:
E-Mail Address: School Number: 99
Student Information Phone # (class schedule and enrollment information):

Is this institution a California public educational institution?
Yes (If yes, move to the Administrative Contact box below) No (If no, answer the following question)
Is your institution "approved" by the Department of Consumer Affairs, Bureau for Private Post Secondary Education (BPPVE)?
Yes (If yes, provide proof of BPPVE "approval" with application)
No (Contact BPPVE at (916) 445-3427 for approval, or to obtain a waiver) BAR cannot accept this application without approval or a waiver from BPPVE..

Provide the name of the automotive department head or administrative person who will be responsible for coordinating bureau-approved training courses, maintaining records, and be responsible for receiving, distributing, and responding to all bureau correspondence.

Administrative Contact Person:
Mailing Address (if different from address listed above):
City: County: Zip:
Phone Number: Ext. #:

Table with 4 columns: Bureau Certified Instructor's Name, Instructor's Certification #, Cert. Exp. Date, Instructor is Advanced Certified? (Yes/No). Rows #1, #2, #3.

**BASIC AREA TECHNICIAN TRAINING INSTITUTION**

To be certified to teach Basic area technician training courses, your institution must employ either a "Basic" or "Advanced" bureau certified instructor, and have the following tools, equipment, educational materials, and lecture and laboratory facilities:

What is the maximum legal student seating capacity of your lecture facility? \_\_\_\_\_

**Note: Do not write in shaded area**

**- Bureau Use Only -  
Inspector Field Audit Area**

Adequate lecture and laboratory facilities to accommodate the number of students to be instructed.

Emission Test Analyzer System (TAS - BAR 90ET or BAR 97 EIS) approved by the bureau for use in a Basic Program Area

Instructional Materials for Basic Area Technician Courses) *(only for courses being taught; see page 4)*

Demonstration Vehicles (5 computer controlled vehicles required):

YES	NO
_____	_____
_____	_____
_____	_____
_____	_____

Note: At least one vehicle must be owned, leased, rented or donated to your institution. Provide documentation of this vehicle with application.

License or Vehicle Identification #	Year	Make	Model	Computer Format OBD I or OBD II

Engine performance analyzer (with printer)

Tachometer/dwell meter

Ammeter

Video equipment: (Minimum) 1- VCR, 1- 25" TV (or 2 - 19")

Digital Volt/Ohm Meters (DVOM) (4 minimum)

Fillpipe restrictor dowel gauges (2 minimum)

Timing lights with advance testing capabilities (2 minimum)

Propane Enrichment Tool

YES	NO
_____	_____
_____	_____
_____	_____
_____	_____
_____	_____
_____	_____
_____	_____



**Basic Area Technician Training Courses** (check the courses your institution wishes to be certified to provide):

- Basic Clean Air Car Course
- Citation Retraining for Basic Area Technicians
- Bureau Training Program (ASE Alternative Courses A6, A8, & L1)
- Update Training for Basic Area Technicians

**Advanced Emission Specialist Technician Training Courses** (check the courses your institution wishes to be certified to provide):

- Advanced Clean Air Car Course
- Citation retraining for Advanced Emission Specialist technicians
- BAR 97 Transition Class
- Update Training for Advanced Emission Specialist technicians

---

**I certify under penalty of perjury under the laws of the State of California that the statements in this application and supporting documents pertaining to this application are true and correct.**

Signature of Administrative Contact Person: \_\_\_\_\_ Date: \_\_\_\_\_

Print Name: \_\_\_\_\_ Title: \_\_\_\_\_ County Where signed: \_\_\_\_\_

Upon the receipt of a completed and qualifying initial application, a bureau field representative will contact your school to schedule a site inspection. Once certified, your institution will be contacted by a bureau representative to make periodic site inspections.

**Note:** Passing the site inspection **does not constitute certification** of your institution. Your institution **cannot** commence bureau certified training courses, until you receive written approval from this office.

**AUTHORITY:**

**Note:** Authority cited: Sections 44002, 44016 and 44030, Health and Safety Code; and Section 9882, Business and Professions Code. Reference: Sections 44010.5, 44012, 44014, 44014.2, 44014.7, 44016, 44030, 44036(a) and (b), 44050 and 44051.5, Health and Safety Code.

**HISTORY**

1. Amendment of section heading filed 8-24-88; operative 9-23-88 (Register 88, No. 37).
2. Amendment filed 4-16-90; operative 4-16-90 (Register 90, No. 19).
3. Editorial correction of printing error correcting section heading (Register 91, No. 6).
4. Amendment of subsection (c) filed 8-18-92; operative 9-17-92 (Register 92, No. 37).
5. New section heading, new subsection (d) and amendment of Note filed 7-26-96 as an emergency; operative 7-26-96 (Register 96, No. 30). A Certificate of Compliance must be transmitted to OAL by 11-25-96 or emergency language will be repealed by operation of law on the following day.
6. Editorial correction of subsection (d) (Register 97, No. 2).
7. Certificate of Compliance as to 7-26-96 order transmitted to OAL 11-19-96 and filed 1-6-97 (Register 97, No. 2).
8. New subsection (e) and new Forms T1-T6 filed 2-1-2001; operative 2-1-2001 pursuant to Government Code section 11343.4(c) (Register 2001, No. 5).
9. Amendment of subsections (a)-(c) filed 6-9-2003; operative 7-9-2003 (Register 2003, No. 24).
10. Amendment of section heading, section and Note filed 5-30-2006; operative 6-29-2006 (Register 2006, No. 22).

**§ 3340.41.3. Invoice Requirements.**

The invoice for service, adjustments or repairs performed as part of the smog check program shall describe all service work done and parts supplied to reduce emissions, in the manner prescribed by section 9884.8 of the Business and Professions Code.

A general description, such as "low-emissions tune up," "scope and adjust," "reduce emissions," or the like is insufficient to satisfy the requirements of section 9884.8 of the Business and Professions Code.

**AUTHORITY:**

**Note:** Authority cited: Section 44002, Health and Safety Code; and Section 9882, Business and Professions Code. Reference: Section 44015(b), Health and Safety Code; and Sections 9884.7(1)(a) and 9884.8, Business and Professions Code.

**HISTORY**

1. New section filed 8-24-88; operative 9-23-88 (Register 88, No. 37).
2. Amendment filed 4-16-90; operative 4-16-90 (Register 90, No. 19).

**§ 3340.41.5. Tampering with Emissions Control Systems.**

A tampered emissions control system is an emissions control system which is missing, modified or disconnected. An emissions control system which has a missing, modified, or disconnected emissions related component is also deemed a tampered emissions control system. For purposes of the visual emission control system inspection pursuant to Health and Safety Code Section 44012(a), the terms missing, modified and disconnected are defined as follows:

(a) Missing. A missing emissions control system or component is one which has been removed from the vehicle or engine.

(b) Modified. An emissions control system is deemed to have been modified if:

(1) the system has been disabled, even though it is present and properly connected to the engine and/or vehicle;

(2) an emissions related component of the system has been replaced by a component not marketed by its manufacturer for street use on the vehicle; or

(3) an emissions related component of the system has been changed such that there is no capacity for connection with or operation of other emissions control components or systems;

(c) Disconnected. A disconnected hose, wire, belt or component is one which is required for the operation of an emissions control system and which has been disconnected.

**AUTHORITY:**

**Note:** Authority cited: Section 44002, Health and Safety Code; and Section 9882, Business and Professions Code. Reference: Sections 44012(a), 44013(b) and 44017, Health and Safety Code.

**HISTORY**

1. New section filed 11-7-84; effective thirtieth day thereafter (Register 84, No. 45).

**§ 3340.42. Smog Check Test Methods and Standards.**

Smog check inspection methods are prescribed in the Smog Check Manual, referenced by section 3340.45.

(a) All vehicles subject to a smog check inspection, shall receive one of the following test methods:

(1) A loaded-mode test shall be the test method used to inspect 1976 - 1999 model-year vehicle, except diesel-powered, registered in the enhanced program areas of the state. The loaded-mode test shall measure hydrocarbon, carbon monoxide, carbon dioxide and oxides of nitrogen emissions, as contained in the bureau's specifications referenced in subsection (a) of Section 3340.17 of this article. The loaded-mode test shall use Acceleration Simulation Mode (ASM) test equipment, including a chassis dynamometer, certified by the bureau.

On and after March 31, 2010, exhaust emissions from a vehicle subject to this inspection shall be measured and compared to the emissions standards shown in the Vehicle Look-up Table (VLT) Row Specific Emissions Standards (Cutpoints) Table, dated March 2010, which is hereby incorporated by reference. If the emissions standards for a specific vehicle are not included in this table then the exhaust emissions shall be compared to the emissions standards set forth in TABLE I or TABLE II, as applicable. A vehicle passes the loaded-mode test if all of its measured emissions are less than or equal to the applicable emission standards specified in the applicable table.

(2) A two-speed idle mode test shall be the test method used to inspect 1976 - 1999 model-year vehicles, except diesel-powered, registered in all program areas of the state, except in those areas of the state where the enhanced program has been implemented. The two-speed idle mode test shall measure hydrocarbon, carbon monoxide and carbon dioxide emissions at high RPM and again at idle RPM, as contained in the bureau's specifications referenced in subsection (a) of Section 3340.17 of this article. Exhaust emissions from a vehicle subject to this inspection shall be measured and compared to the emission standards set forth in this section and as shown in TABLE III. A vehicle passes the two-speed idle mode test if all of its measured emissions are less than or equal to the applicable emissions standards specified in Table III.

(3) An OBD-focused test, shall be the test method used to inspect gasoline-powered vehicles 2000 model-year and newer, and diesel-powered vehicles 1998 model-year and newer. The OBD test failure criteria are specified in section 3340.42.2.

(b) In addition to subsection (a), all vehicles subject to the smog check program shall receive the following:

(1) A visual inspection of emission control components and systems to verify the vehicle's emission control systems are properly installed.

(2) A functional inspection of emission control systems as specified in the Smog Check Manual, referenced by section 3340.45, which may include an OBD test, to verify their proper operation.

(c) The bureau may require any combination of the inspection methods in sections (a) and (b) under any of the following circumstances:

(1) Vehicles that the department randomly selects pursuant to Health and Safety Code section 44014.7 as a means of identifying potential operational problems with vehicle OBD systems.

(2) Vehicles identified by the bureau as being operationally or physically incompatible with inspection equipment.

(3) Vehicles with OBD systems that have demonstrated operational problems.

(d) Pursuant to section 39032.5 of the Health and Safety Code, gross polluter standards are as follows:

(1) A gross polluter means a vehicle with excess hydrocarbon, carbon monoxide, or oxides of nitrogen emissions pursuant to the gross polluter emissions standards included in the tables described in subsection (a), as applicable.

(2) Vehicles with emission levels exceeding the emission standards for gross polluters during an initial inspection will be considered gross polluters and the provisions pertaining to gross polluting vehicles will apply, including, but not limited to, sections 44014.5, 44015, and 44081 of the Health and Safety Code.

(3) A gross polluting vehicle shall not be passed or issued a certificate of compliance until the vehicle's emissions are reduced to or below the applicable emissions standards for the vehicle included in the tables described in subsection (a), as applicable. However, the provisions described in section 44017 of the Health and Safety Code may apply.

(4) This subsection applies in all program areas



Table I  
Acceleration Simulation Mode  
Emission Standards and Gross Polluter Standards

ESC	MODEL YEAR GROUP	VEHICLE TYPE (by GVWR and LVM)				PASS/FAIL EMISSION STANDARD						GROSS POLLUTER STANDARD									
		PC	LDT1	LDV2	MDV/HDV	ASM 5015	HC	NO	CO	ASM 2525	HC	NO	CO	ASM 5015	HC	NO	CO	ASM 2525	HC	NO	CO
1	1974-	X	X	X		235.4	2.56	1301.5	185.4	1161.5	435.4	4.26	2859.3	385.4	4.08	2459.3	408	4.08	2459.3	408	
2	1975-1980	X				436041.7	4453.19	1192593.0	436041.7	1192593.0	436041.7	4453.19	1703703.7	436041.7	4453.19	1703703.7	436041.7	4453.19	1703703.7	436041.7	
3	1981-1983	X				123.0	0.91	1016.3	90.3	876.3	315.3	2.51	2051.9	265.3	2.31	1851.9	265.3	2.31	1851.9	265.3	
4	1984-1986	X				273316.7	1362.96	1043519.0	273316.7	1362.96	1043519.0	273316.7	1362.96	1490740.7	273316.7	1362.96	1490740.7	273316.7	1362.96	1490740.7	273316.7
5	1987-1992	X				63.2	0.64	850.0	42.1	680.0	253.1	2.14	1844.4	192.4	1.94	1644.4	192.4	1.94	1644.4	192.4	
6	1993-1996	X				234259.3	1064.81	894444.5	212963.0	1064.81	894444.5	234259.3	1064.81	127777.8	212963.0	1064.81	127777.8	212963.0	1064.81	127777.8	212963.0
7	1996-2000	X				212963.0	979.63	894444.5	212963.0	979.63	894444.5	212963.0	979.63	12777.8	212963.0	979.63	12777.8	212963.0	979.63	12777.8	212963.0
8	2001-2003	X				191666.7	851.85	596296.3	191666.7	851.85	596296.3	191666.7	851.85	191666.7	191666.7	851.85	191666.7	191666.7	851.85	191666.7	191666.7
9	2004+	X				89951.3	724.07	271314.8	89951.3	851.85	596296.3	851.85	596296.3	128501.9	128501.9	724.07	553703.7	128501.9	851.85	553703.7	128501.9
10	1975-1978	X				16.8	0.29	260.0	0.5	547.0	234.3	1.79	1759.3	184.3	1.73	1559.3	184.3	1.73	1559.3	184.3	
11	1979-1983	X				128501.9	724.07	596296.3	128501.9	851.85	596296.3	128501.9	724.07	553703.7	128501.9	851.85	553703.7	128501.9	851.85	553703.7	128501.9
12	1984-1987	X				16.8	0.29	260.0	0.5	547.0	234.3	1.79	1759.3	184.3	1.73	1559.3	184.3	1.73	1559.3	184.3	
13	1988-1992	X				128501.9	724.07	596296.3	128501.9	851.85	596296.3	128501.9	724.07	553703.7	128501.9	851.85	553703.7	128501.9	851.85	553703.7	128501.9
14	1993-1996	X				139.4	1.08	1320.9	105.0	1180.9	330.0	2.58	2487.0	280.0	2.38	2287.0	280.0	2.38	2287.0	280.0	
15	1996-2000	X				225000.0	2025.00	745370.4	225000.0	2025.00	745370.4	225000.0	2025.00	1064814.8	225000.0	2025.00	1064814.8	225000.0	2025.00	1064814.8	225000.0
16	2001-2003	X				139.4	0.88	1315.7	80.0	1175.7	320.0	2.38	2479.6	255.0	2.18	2279.6	255.0	2.18	2279.6	255.0	
17	2004+	X				225000.0	2025.00	596296.3	150000.0	2025.00	596296.3	225000.0	2025.00	150000.0	225000.0	2025.00	150000.0	225000.0	2025.00	150000.0	225000.0
18	1975-1978	X				150000.0	1725.00	525000.0	150000.0	1050000.0	150000.0	1725.00	750000.0	150000.0	1725.00	750000.0	150000.0	1725.00	750000.0	150000.0	1725.00
19	1979-1983	X				150000.0	1725.00	525000.0	150000.0	1050000.0	150000.0	1725.00	750000.0	150000.0	1725.00	750000.0	150000.0	1725.00	750000.0	150000.0	1725.00
20	1984-1987	X				83.0	0.27	875.0	63.1	735.0	270.0	1.57	1600.0	220.0	1.73	1400.0	220.0	1.73	1400.0	220.0	
21	1988-1992	X				83.0	0.27	875.0	63.1	735.0	270.0	1.57	1600.0	220.0	1.73	1400.0	220.0	1.73	1400.0	220.0	
22	1993-1996	X				68.3	0.30	377.0	33.3	630.0	247.5	1.60	1350.0	197.5	1.70	1400.0	197.5	1.70	1400.0	197.5	
23	1996-2000	X				78750.0	1350.00	525000.0	78750.0	1350.00	525000.0	78750.0	1350.00	112500.0	78750.0	1350.00	112500.0	78750.0	1350.00	112500.0	78750.0
24	2001-2003	X				22.1	0.30	377.0	5.8	630.0	247.5	1.60	1350.0	197.5	1.70	1400.0	197.5	1.70	1400.0	197.5	
25	2004+	X				22.1	0.30	377.0	5.8	630.0	247.5	1.60	1350.0	197.5	1.70	1400.0	197.5	1.70	1400.0	197.5	

1 of 2  
TABLE I.XIS  
modified: 10/31/2001

**Table I**  
**Acceleration Simulation Mode**  
**Emission Standards and Gross Polluter Standards**

ESC GROUP	MODEL YEAR	VEHICLE TYPE				PASS/FAIL EMISSION STANDARD						GROSS POLLUTER STANDARD						
		(by GVWR and LVM)		(MDV)		ASM 5015			ASM 2525			ASM 5015			ASM 2525			
		PC	LDT1	LDT2	MDV	HDV	HC	CO	NO	HC	CO	NO	HC	CO	NO	HC	CO	NO
26	1978-				X		173.3	2.90	1703.3	123.3	2.70	1563.3	423.3	5.40	3233.3	373.3	5.20	3033.3
						A	583333.3	3500.00	1633333.3	583333.3	3500.00	1633333.3	583333.3	3500.00	2333333.3	583333.3	3500.00	2333333.3
27	1979-1983				X		139.4	0.98	1315.7	80.0	0.68	1175.7	320.0	2.38	2479.6	255.0	2.18	2279.6
						B	225000.0	2025.00	596296.3	150000.0	2025.00	596296.3	225000.0	2025.00	851851.9	150000.0	2025.00	851851.9
28	1984-1987				X		81.3	0.41	945.0	63.1	0.50	840.0	280.0	1.71	1850.0	230.0	1.80	1700.0
						A	150000.0	1725.00	525000.0	150000.0	2250.00	1050000.0	150000.0	1725.00	750000.0	150000.0	2250.00	1500000.0
29	1988-1992				X		83.0	0.27	875.0	63.1	0.43	735.0	270.0	1.57	1800.0	220.0	1.73	1400.0
						A	150000.0	1725.00	525000.0	150000.0	1875.00	525000.0	150000.0	1725.00	750000.0	150000.0	1875.00	750000.0
30	1993-1995				X		83.0	0.30	875.0	60.0	0.70	735.0	300.0	1.80	1750.0	250.0	2.00	1550.0
						B	150000.0	1350.00	525000.0	150000.0	1500.00	525000.0	150000.0	1350.00	750000.0	150000.0	1500.00	750000.0
31	1996-2000				X		71.2	0.30	875.0	60.0	0.70	735.0	300.0	1.60	1750.0	250.0	2.00	1550.0
						B	150000.0	1350.00	525000.0	150000.0	1500.00	525000.0	150000.0	1350.00	750000.0	150000.0	1500.00	750000.0
32	2001-2003				X		71.2	0.30	875.0	60.0	0.70	735.0	300.0	1.60	1750.0	250.0	2.00	1550.0
						A	150000.0	1350.00	525000.0	150000.0	1500.00	525000.0	150000.0	1350.00	750000.0	150000.0	1500.00	750000.0
33	2004+				X		71.2	0.30	875.0	60.0	0.70	735.0	300.0	1.60	1750.0	250.0	2.00	1550.0
						B	150000.0	1350.00	525000.0	150000.0	1500.00	525000.0	150000.0	1350.00	750000.0	150000.0	1500.00	750000.0
34	1978-				X		243.8	3.92	2615.8	189.8	3.92	2770.8	584.9	7.29	4870.0	605.4	7.57	5375.4
						B	583333.3	3500.00	1633333.3	583333.3	3500.00	1633333.3	583333.3	3500.00	1633333.3	583333.3	3500.00	1633333.3
35	1979 - 1983				X		205.5	2.16	2250.6	106.0	1.96	2400.6	454.2	6.62	4231.1	338.1	6.54	4657.2
						B	225000.0	2025.00	596296.3	150000.0	2025.00	596296.3	225000.0	2025.00	596296.3	150000.0	2025.00	596296.3
36	1984 - 1987				X		143.0	1.60	2182.5	78.0	1.80	1975.0	307.5	6.67	4238.5	250.0	6.48	3885.9
						B	150000.0	1725.00	525000.0	150000.0	2250.00	1050000.0	150000.0	1725.00	525000.0	150000.0	2250.00	1050000.0
37	1988 - 1992				X		105.0	1.01	2112.5	78.0	1.24	2062.5	300.0	5.87	3865.9	250.0	4.98	3929.9
						B	150000.0	1725.00	525000.0	150000.0	1875.00	525000.0	150000.0	1725.00	525000.0	150000.0	1875.00	525000.0
38	1993 - 1995				X		105.0	0.49	1912.5	75.0	1.22	1862.5	300.0	2.61	3825.0	250.0	3.49	3929.9
						B	150000.0	1350.00	525000.0	150000.0	1500.00	525000.0	150000.0	1350.00	750000.0	150000.0	1500.00	750000.0
39	1996 - 2000				X		105.0	0.49	1662.5	75.0	1.16	1462.5	300.0	2.61	3325.0	250.0	3.32	3085.9
						B	150000.0	1350.00	525000.0	150000.0	1500.00	525000.0	150000.0	1350.00	750000.0	150000.0	1500.00	750000.0
40	2001+				X		105.0	0.49	1662.5	75.0	1.16	1462.5	300.0	2.61	3325.0	250.0	3.32	3085.9
						B	150000.0	1350.00	525000.0	150000.0	1500.00	525000.0	150000.0	1350.00	750000.0	150000.0	1500.00	750000.0

**Legend:**  
 ESC - Emissions Standard Category  
 GVWR - Manufacturer's Gross Vehicle Weight Rating  
 LVM - Loaded Vehicle Weight  
 HC - Hydrocarbon, ppm  
 CO - Carbon Monoxide, %  
 NO - Nitric Oxide, ppm  
**Pass/Fail Emission Standards = A + B / VTW**

PASS/FAIL STANDARDS - Emission standards used to determine if a vehicle passes the emission inspection. A vehicle passes if the emission levels are equal to or less than the standards for HC, CO and NO for ASM 5015 and ASM2525.  
 GROSS POLLUTER STANDARDS - Emission standards used to designate a vehicle as a gross polluter. A vehicle is designated as a gross polluter if the emissions levels at the time of the initial inspection, before repairs are greater than the gross polluter standards for HC, CO or NO for ASM 5015 or ASM2525.

**NOTE:**  
 If test data on emission pass/fail rates or gross polluter identification rates indicate adjustments are required, the emission standards may be increased or decreased by the bureau by 30% or by the following tolerances, or standards may be set for any specific vehicle and engine configuration which the bureau determines has excessive errors of commission or omission, whichever is necessary to comply with Section 44001.5 of the Health and Safety Code.  
 HC = 150 ppm, CO = 1.50%, NO = 350 ppm.



**TABLE III**  
**Emission Standards, Gross Polluter Standards, Dilution Thresholds**  
**and Maximum Idle RPM Limits for BAR-90 Two-speed Test**

E S C	MODEL YEAR GROUP	VEHICLE TYPE (by GVWR)			PASS/FAIL STANDARDS						GROSS POLLUTER STANDARDS					
		PASSENGER ≤6,000	TRUCK (includes motorhome, minivan, sport utility)		IDLE HC	IDLE CO	2500 HC	2500 CO	IDLE HC	IDLE CO	2500 HC	2500 CO	MIN CO+CO <sub>2</sub>	MAX IDLE RPM		
			6,001 to 8,500	8,501 to 14,000											≥14,001	
1	1966-1967	X	X		700	5.5	600	4.5	950	8.0	850	7.0	8.0	1100		
2	1968-1970	X	X		650	5.5	600	4.5	900	8.0	850	7.0	8.0	1100		
3	1971-1974	X	X		550	5.0	400	4.0	800	7.5	650	6.5	8.0	1100		
4	1975-1980	X	X		220	2.0	180	1.7	470	4.5	430	4.2	8.0	1100		
5	1981-1983	X	X		120	1.5	150	1.5	270	3.0	300	3.0	8.0	1100		
6	1984-1986	X	X		120	1.0	150	1.2	270	2.5	300	2.7	7.0	1100		
7	1987-1992	X	X		120	1.0	140	1.0	270	2.5	290	2.5	7.0	1100		
8	1993+	X	X		100	1.0	130	1.0	250	2.5	280	2.5	8.0	1100		
9	1975-1978		X		250	2.5	200	3.0	500	5.0	450	5.5	7.0	1100		
10	1979-1983		X	X	250	2.0	200	2.0	400	3.5	350	3.5	8.0	1100		
11	1984-1987		X	X	150	1.2	180	1.2	300	2.7	330	2.7	7.0	1100		
12	1988-1992		X	X	120	1.0	180	1.0	270	2.5	330	2.5	8.0	1100		
13	1993+		X		100	1.0	170	1.0	250	2.5	320	2.5	7.0	1100		
14	1993+		X	X	100	1.0	180	1.1	250	2.5	330	2.6	7.0	1200		
15	1966-1969		X	X	700	5.5	750	5.0	950	8.0	1000	7.5	7.0	1200		
16	1970-1973		X	X	550	5.0	600	4.5	800	7.5	850	7.0	8.0	1200		
17	1974-1978		X	X	300	3.0	350	3.5	550	5.5	600	6.0	7.0	1200		
18	1979-1983		X	X	250	2.2	250	3.0	400	3.7	400	4.5	7.0	1200		
19	1984-1986		X	X	250	1.5	200	1.6	400	3.0	350	3.1	7.0	1200		
20	1987-1990		X	X	220	1.5	200	1.6	370	3.0	350	3.1	7.0	1100		
21	1991+		X	X	150	1.2	150	1.5	300	2.7	300	3.0	7.0	1100		
22	1987-1990		X	X	250	2.5	200	1.6	400	4.0	350	3.1	7.0	1100		
23	1991+		X	X	150	1.5	150	1.5	300	3.0	300	3.0	7.0	1100		
24	1970-1978		X	X	550	5.0	600	4.5	800	7.5	850	7.0	8.0	1200		

Legend:  
 ESC = Emissions Standards Category  
 GVWR = Manufacturer's Gross Vehicle Weight Rating

PASS/FAIL STANDARDS = Emission standards used to determine if a vehicle passes the emissions portion of the inspection. A vehicle passes if the emission levels are equal to or less than the hydrocarbon or carbon monoxide standard for the idle or 2500 RPM inspection.

GROSS POLLUTER STANDARDS = Emissions standards used to designate a vehicle as a gross polluter. A vehicle is designated as a gross polluter if the emissions levels at the time of the initial inspection, are greater than the gross polluter standards for hydrocarbon or carbon monoxide for the idle or 2500 RPM inspection.

HC = Hydrocarbon  
 CO = Carbon Monoxide  
 MIN. CO + CO<sub>2</sub> = Minimum CO + CO<sub>2</sub> dilution threshold  
 MAX. IDLE RPM = Maximum idle RPM limits

NOTE: If test data on emission pass/fail rates or gross polluter identification rates indicate adjustments are required, the emission standards may be increased or decreased by the bureau by 30% or by the following tolerances; or standards may be set for any specific vehicle and engine configuration which the bureau determines has excessive errors of commission or omission, whichever is necessary to comply with section 44001.5 of the Health and Safety Code.

CO = 1.50%  
 HC = 150 ppm  
 NOx = 350 ppm  
 CO + CO<sub>2</sub> = 5%  
 Maximum Idle 500 RPM

**AUTHORITY:**

**Note:** Authority cited: Sections 44001.5, 44002, 44003, 44012, 44012.1, 44013 and 44036, Health and Safety Code; and Section 9882, Business and Professions Code. Reference: Sections 39032.5, 44002, 44003, 44005, 44010, 44011, 44011.3, 44012, 44012.1, 44013, 44014, 44014.5, 44014.7, 44015, 44017.1, 44032, 44033, 44036, 44037.1, 44062.1 and 44081, Health and Safety Code; and Sections 9884.8 and 9884.9, Business and Professions Code.

**HISTORY**

1. Editorial correction of printing error (Register 84, No. 32).
2. Amendment filed 4-16-90; operative 4-16-90 (Register 90, No. 19).
3. Amendment of Table II filed 5-11-90; operative 6-10-90 (Register 90, No. 26).
4. Amendment of section and Note, repealer and new Tables I-II, and new Table III filed 6-22-95 as an emergency; operative 6-22-95 (Register 95, No. 25). A Certificate of Compliance must be transmitted to OAL by 10-20-95 or emergency language will be repealed by operation of law on the following day.
5. Certificate of Compliance as to 6-22-95 order including amendment of section and Tables I-III transmitted to OAL 10-20-95 and filed 12-1-95 (Register 95, No. 48).
6. Amendment of first paragraph filed 4-29-96 as an emergency; operative 4-29-96 (Register 96, No. 18). A Certificate of Compliance must be transmitted to OAL by 8-27-96 or emergency language will be repealed by operation of law on the following day.
7. Amendment of opening paragraph and subsection (b), repealer of subsection (c)(5) and subsection renumbering and amendment of newly designated subsection (c)(5) filed 7-26-96 as an emergency; operative 7-26-96 (Register 96, No. 30). A Certificate of Compliance must be transmitted to OAL by 11-25-96 or emergency language will be repealed by operation of law on the following day.
8. Certificate of Compliance as to 4-29-96 order transmitted to OAL 8-21-96 and filed 9-30-96 (Register 96, No. 40).
9. Certificate of Compliance as to 7-26-96 order, including amendment of first paragraph and subsections (a)(1)(C)1.-3. and (b), transmitted to OAL 11-19-96 and filed 1-6-97 (Register 97, No. 2).
10. Amendment of Table III filed 4-4-97 as an emergency; operative 4-4-97 (Register 97, No. 14). A Certificate of Compliance must be transmitted to OAL by 8-4-97 or emergency language will be repealed by operation of law on the following day.
11. Editorial correction of first paragraph (Register 97, No. 33).
12. Certificate of Compliance as to 4-4-97 order transmitted to OAL 7-2-97 and filed 8-13-97 (Register 97, No. 33).
13. Amendment of section heading, section and Note filed 9-10-2001; operative 9-10-2001 pursuant to Government Code section 11343.4 (Register 2001, No. 37).
14. Amendment of first paragraph filed 2-15-2002 as an emergency; operative 2-15-2002 (Register 2002, No. 7). A Certificate of Compliance must be transmitted to OAL by 6-17-2002 or emergency language will be repealed by operation of law on the following day.
15. Repealer and new Table I filed 5-28-2002; operative 6-27-2002 (Register 2002, No. 22).
16. Certificate of Compliance as to 2-15-2002 order transmitted to OAL 6-13-2002 and filed 7-26-2002 (Register 2002, No. 30).
17. Amendment of section and repealer and new Table II filed 1-21-2003; operative 2-20-2003 (Register 2003, No. 4).
18. Change without regulatory effect amending Table II filed 6-4-2003 pursuant to section 100, title 1, California Code of Regulations (Register 2003, No. 23).
19. Amendment of first paragraph filed 6-9-2003; operative 7-9-2003 (Register 2003, No. 24).
20. Change without regulatory effect amending first paragraph and subsections (a)(2)-(3), (b)(3), (b)(6)-(7), (d)(1) and (d)(4) filed 10-11-2006 pursuant to section 100, title 1, California Code of Regulations (Register 2006, No. 41).
21. New subsections (c)-(c)(3), subsection relettering and amendment of Note filed 8-1-2007; operative 8-1-2007 pursuant to Government Code section 11343.4 (Register 2007, No. 31).
22. Amendment of section heading, section and Note and new Figure 1 filed 1-11-2008; operative 1-11-2008 pursuant to Government Code section 11343.4 (Register 2008, No. 2).
23. Editorial correction of subsections (a) and (f) (Register 2008, No. 44).
24. Amendment filed 11-5-2009; operative 12-5-2009 (Register 2009, No. 45).
25. Amendment of section heading, section and Note filed 12-16-2009; operative 12-16-2009 pursuant to Government Code section 11343.4 (Register 2009, No. 51).

26. Change without regulatory effect amending subsection (a) filed 7-9-2010 pursuant to section 100, title 1, California Code of Regulations (Register 2010, No. 28).

27. Amendment of section heading and section and repealer of Figure 1 filed 5-2-2013; operative 7-1-2013 (Register 2013, No. 18).

**§ 3340.42.1. Mandatory Exhaust Emissions Inspection Standards and Test Procedures for Heavy-Duty Vehicles Powered by Gasoline.**

**AUTHORITY:**

**Note:** Authority cited: Sections 44002, 44011 and 44013, Health and Safety Code. Reference: Sections 39032.5, 44010.5, 44011, 44012, 44013 and 44036, Health and Safety Code.

**HISTORY**

1. New section filed 8-21-89; operative 1-1-90 (Register 89, No. 34).
2. Amendment of Table III filed 5-11-90; operative 6-10-90 (Register 90, No. 26).
3. Amendment of section and Note and repealer of Table III filed 6-22-95 as an emergency; operative 6-22-95 (Register 95, No. 25). A Certificate of Compliance must be transmitted to OAL by 10-20-95 or emergency language will be repealed by operation of law on the following day.
4. Certificate of Compliance as to 6-22-95 order including amendment of section transmitted to OAL 10-20-95 and filed 12-1-95 (Register 95, No. 48).
5. Repealer filed 1-21-2003; operative 2-20-2003 (Register 2003, No. 4).

**§ 3340.42.2. Test Methods and Standards for the On-Board Diagnostic Inspection.**

(a) Effective until the implementation of subsection (c), Smog Check stations and Smog Check technicians shall conduct tests and inspections in accordance with the Bureau's BAR-97 Emissions Inspection System Specifications referenced in subsections (a) and (b) of Section 3340.17. All applicable 1996 and newer model-year spark ignition passenger vehicles and trucks under 14,001 Gross Vehicle Weight Rating (GVWR) shall be given a test of the On-Board Diagnostic (OBDII) systems. The OBDII test consists of a visual check of the Malfunction Indicator Light (MIL) and a functional test of the readiness indicators and fault code retrieval system.

(b) Effective until the implementation of subsection (c), model-year 1996 through 2000 vehicles having more than two (2) incomplete emissions related readiness monitors, and vehicle model-years 2001 and newer having more than one (1) incomplete emissions related readiness monitor shall fail the OBDII portion of the inspection. All vehicle model-years 1996 and newer having more than two (2) incomplete emissions related readiness monitors shall fail the OBDII portion of the inspection.

(c) Starting on or after January 1, 2013, OBD equipped vehicles shall fail the OBD inspection if any one of the following conditions occurs as applicable to the vehicle:

- (1) The vehicle's MIL does not illuminate when the ignition is on and the engine is off;
- (2) The vehicle's MIL illuminates continuously or flashes with the engine running;
- (3) The vehicle's OBD system reports the MIL as commanded on;
- (4) The vehicle's OBD system reports a Diagnostic Trouble Code (DTC);

(5) The vehicle's OBD system data indicates the system has not yet been sufficiently operated to determine the presence or absence of a DTC;

(6) The vehicle's OBD system does not communicate with the EIS or OIS;

(7) The vehicle's OBD system data is inappropriate for the vehicle being tested;

(8) The vehicle's OBD system data does not match the original equipment manufacturer (OEM) or an Air Resources Board (ARB) exempted OBD software configuration;

(9) The vehicle's OBD system reports incomplete readiness monitor(s) as specified below:

(A) Gasoline-powered vehicles model-years 1996 through 1999 with more than one (1) incomplete monitor,

(B) Gasoline-powered vehicles model-years 2000 and newer with any incomplete monitors, excluding the evaporative system monitor;

(C) Diesel-powered vehicles model-years 1998 through 2006 with any incomplete monitors;

(D) Diesel-powered vehicles model-years 2007 and newer with any incomplete monitors, excluding the particulate filter system monitor.

(d) For the purposes of this section:

(1) On-Board Diagnostics (OBD) means a system of vehicle component and condition monitors controlled by an on-board computer designed to alert the motorist when emission control components or vehicle emission systems are not functioning properly.

(2) Readiness monitor(s) are a status indicator reported by the OBD system that indicates whether or not monitors of specific emission control devices or systems have run a self-diagnostic test.

(3) Diagnostic Trouble Code (DTC) is an alphanumeric code which is set in a vehicle's on-board computer when the OBD system detects an emission control device or system failure.

(4) Malfunction Indicator Light (MIL) is illuminated on the dashboard when the OBD system has detected an emission control device or system failure. Alternatives may include a "Service Engine Soon" or "Check Engine" message, or an unlabeled picture of an engine.

**AUTHORITY:**

**Note:** Authority cited: Sections 44001.5, 44002, 44003, 44013 and 44036, Health and Safety Code; and Section 9882, Business and Professions Code. Reference: Sections 39032.5, 44002, 44003, 44005, 44010, 44011, 44013, 44014, 44015, 44032, 44033, 44036, 44037.1 and 44062.1, Health and Safety Code; and Sections 9884.8 and 9884.9, Business and Professions Code.

**HISTORY**

1. New section filed 11-5-2009; operative 12-5-2009 (Register 2009, No. 45).
2. Amendment of section heading and section filed 5-2-2013; operative 7-1-2013 (Register 2013, No. 18).

**§ 3340.43. Repair Cost Limit.**

(a) Beginning July 1, 2013, and in accordance with Health and Safety Code 44017 (c), a vehicle owner shall qualify for a repair cost waiver only after an expenditure of not less than \$650 in smog check related repairs. The bureau shall revise the maximum repair cost limit based on adjustments to the Consumer Price Index (CPI), as published by the Bureau of Labor Statistics. The expen-

diture amount shall be increased biennially, only if the CPI results in an adjustment of at least \$25 since the last CPI adjustment. The revised repair cost limit shall be rounded to the nearest \$5.

(b) Repairs covered by a vehicle manufacturer emissions warranty shall not apply toward the repair cost limit. Additionally, a vehicle owner shall not qualify for a repair cost waiver if the vehicle is in need of repairs that are covered by a manufacturer's emissions warranty.

(c) Pursuant to subdivision (e) of section 44017 of the Health and Safety Code, the owner of a motor vehicle that has failed the visible smoke test required by subsection (f) of Section 3340.42 and section 44012.1 of the Health and Safety Code, shall only be eligible for the repair cost waiver specified in subdivision (a) of section 44017 if all of the following conditions are met:

(1) The motor vehicle owner has a household income greater than the limit specified in subsection (b) of Section 3394.6, but less than or equal to two hundred fifty percent (250%) of the federal Poverty Guidelines, as published by the United States Department of Health and Human Services.

(2) The motor vehicle owner's household income has been verified in accordance with subsection (b) of Section 3394.6.

(3) The motor vehicle owner is not receiving any form of public assistance from any agency.

(4) The motor vehicle's required emissions control equipment is not missing and has not been rendered partially inoperative or inoperative as a result of tampering.

**AUTHORITY:**

**Note:** Authority cited: Sections 44002, 44015 and 44017, Health and Safety Code; and Section 9882, Business and Professions Code. Reference: Sections 44017 and 44062.1, Health and Safety Code.

**HISTORY**

1. New section filed 1-11-2008; operative 1-11-2008 pursuant to Government Code section 11343.4 (Register 2008, No. 2).
2. Amendment of subsections (a) and (b) filed 3-30-2012; operative 4-29-2012 (Register 2012, No. 13).
3. Amendment of section heading, section and Note filed 5-17-2013; operative 7-1-2013 (Register 2013, No. 20).

**§ 3340.45. Smog Check Manual.**

(a) All Smog Check inspections shall be performed in accordance with requirements and procedures prescribed in the following:

(1) Smog Check Inspection Procedures Manual, dated August 2009, which is hereby incorporated by reference. This manual shall be in effect until subparagraph (2) is implemented.

(2) Smog Check Manual, dated 2013, which is hereby incorporated by reference. This manual shall become effective on or after January 1, 2013.

**AUTHORITY:**

**Note:** Authority cited: Section 44002, Health and Safety Code; and Section 9882, Business and Professions Code. Reference: Sections 44002, 44003, 44005, 44010, 44011, 44011.3, 44012, 44012.1, 44013, 44014, 44014.5, 44014.7, 44015 and 44032, Health and Safety Code.

**HISTORY**

1. New section filed 12-16-2009; operative 12-16-2009 pursuant to Government Code section 11343.4 (Register 2009, No. 51). For prior history of section 3340.45, see Register 90, No. 19.
2. Amendment of section heading and section filed 5-2-2013; operative 7-1-2013 (Register 2013, No. 18).

### § 3340.50. Fleet Facility Requirements.

The owner of a fleet of vehicles shall meet the following requirements for licensure as a fleet facility smog check station, if they choose to be so licensed, and shall comply with these requirements at all times while licensed.

(a) **Number of Fleet Vehicles.** The fleet facility shall own and operate a fleet of 10 or more vehicles which are subject to the program and are exclusively for the use of fleet employees, for sale, or for rental or lease to members of the public in the regular course of business.

(b) **Equipment.** The fleet facility shall have the equipment required by a smog check station, as set forth in sections 3340.16.5 and 3340.17 of this chapter. Equipment shall be maintained and calibrated in accordance with section 3340.17 of this chapter.

(c) **Licensed Inspector and/or Repair Technician.** A licensed inspector and/or repair technician shall be present at the facility when necessary to test, inspect, or repair a vehicle. Testing and/or repairing of vehicles pursuant to the Smog Check Program shall be performed by a licensed inspector and/or repair technician, consistent with their license classification.

(d) **Work Area.** The work area shall meet all the requirements specified in section 3340.15(a) of this article.

(e) **Vehicles Serviced.** A licensed fleet facility shall test, repair, and certify only vehicles owned by it. The repair cost limit shall not apply to the repair of fleet vehicles.

(f) **Onsite Inspection.** The responsible managing employee of the fleet facility shall provide the bureau with whatever access, information, and other cooperation is necessary to facilitate onsite inspection of the fleet's vehicles or inspection system. At the bureau's request, the licensed inspector and/or repair technician shall be present during regular business hours (8 a.m. to 5 p.m.) at a time agreed upon by the licensed inspector and/or repair technician and a bureau representative.

(g) **Display of Licenses.** The station license and inspector and/or repair technician licenses shall be posted prominently in an area accessible to the bureau or its representative.

(h) **Manuals and Bulletins.** Bureau manuals and bulletins pertaining to fleet facilities shall be maintained in a location readily accessible to licensed inspector and/or repair technicians.

#### AUTHORITY:

**Note:** Authority cited: Section 44002, Health and Safety Code. Reference: Sections 44020 and 44045.5, Health and Safety Code.

#### HISTORY

1. Amendment of subsection (e) filed 8-24-88; operative 9-23-88 (Register 88, No. 37).
2. Amendment filed 4-16-90; operative 4-16-90 (Register 90, No. 19).
3. Editorial correction of printing error in subsection (e) (Register 91, No. 6).
4. Amendment filed 6-23-95 as an emergency; operative 6-23-95 (Register 95, No. 25). A Certificate of Compliance must be transmitted to OAL by 10-21-95 or emergency language will be repealed by operation of law on the following day.
5. Certificate of Compliance as to 6-23-95 order transmitted to OAL 10-20-95 and filed 12-6-95 (Register 95, No. 49).
6. Amendment of subsections (b) and (c) filed 7-26-96 as an emergency; operative 7-26-96 (Register 96, No. 30). A Certificate of Compliance must be transmitted to OAL by 11-25-96 or emergency language will be repealed by operation of law on the following day.

7. Certificate of Compliance as to 7-26-96 order, including amendment of first paragraph, transmitted to OAL 11-19-96 and filed 1-6-97 (Register 97, No. 2).

8. Amendment of subsection (b) filed 2-15-2002 as an emergency; operative 2-15-2002 (Register 2002, No. 7). A Certificate of Compliance must be transmitted to OAL by 6-17-2002 or emergency language will be repealed by operation of law on the following day.

9. Certificate of Compliance as to 2-15-2002 order transmitted to OAL 6-13-2002 and filed 7-26-2002 (Register 2002, No. 30).

10. Amendment of subsection (c), repealer of subsection (d), subsection relettering and amendment of newly designated subsections (f)-(h) filed 2-1-2012; operative 2-1-2012 pursuant to Government Code section 11343.4 (Register 2012, No. 5).

### § 3340.50.1. Application for Fleet Facility License; Renewal; Replacement.

(a) **Initial License.** To become licensed as a fleet facility, a fleet owner shall submit an application on a form prescribed by the bureau. The fleet facility license shall expire one year from the last day of the month in which the license was issued. A fleet facility license is not transferable.

(b) **Renewal.** A fleet facility licensee shall submit a timely and proper renewal application to the bureau. A licensee whose license has expired shall immediately cease to inspect or test vehicles or issue certificates.

(c) **Duplicate Licenses.** Application for a duplicate license shall be made to the bureau in accordance with Section 3340.10(e) of this article.

(d) **Replacement License.** Replacement of licenses shall be handled in accordance with Section 3340.10(e) of this article, except that no fee is required.

#### AUTHORITY:

**Note:** Authority cited: Section 44020 of the Health and Safety Code. Reference 44020, Health and Safety Code.

### § 3340.50.3. Fleet Records and Reporting Requirements.

(a) All data relating to licensed test and repair activities shall be recorded on forms supplied by the bureau.

(b) The licensed fleet facility shall maintain certificate books prescribed by the bureau. All required information shall be recorded on the certificate by the licensed technician on the day the final test on a vehicle was performed. Each certificate shall be signed and dated by the licensed technician on the day of the final test on a vehicle. For permanently registered fleets, an alternate procedure for certifying vehicles may be allowed by the bureau.

(c) The records required to be maintained by subsections (a) and (b) shall be retained for a period of not less than three years after the completion of any test or repair to which the records refer.

#### AUTHORITY:

**Note:** Authority cited: Section 44002 and 44020(a) and (b) of the Health and Safety Code. Reference: Sections 44020 and 44045.5, Health and Safety Code.

#### HISTORY

1. Amendment of subsection (b) and NOTE filed 6-23-95 as an emergency; operative 6-23-95 (Register 95, No. 25). A Certificate of Compliance must be transmitted to OAL by 10-21-95 or emergency language will be repealed by operation of law on the following day.
2. Certificate of Compliance as to 6-23-95 order transmitted to OAL 10-20-95 and filed 12-6-95 (Register 95, No. 49).

**§ 3340.50.4. Fleet Certificates.**

(a) A licensed fleet facility shall order and purchase a certificate of compliance, or noncompliance from the bureau or an authorized agent of the bureau only, for a fee determined pursuant to section 3340.35.1 of these regulations. A certificate of compliance or noncompliance is not transferable.

(b) A certificate of compliance shall be issued only for a vehicle that complies with the emission control system requirements and meets the exhaust emission standards established by the bureau.

**AUTHORITY:**

**Note:** Authority cited: Sections 44002, 44020 and 44060, Health and Safety Code. Reference: Sections 44010, 44020(c) and 44060, Health and Safety Code.

**HISTORY**

1. Amendment of subsection (a) filed 8-24-88; operative 9-23-88 (Register 88, No. 37).
2. Amendment of subsection (a) filed 1-25-89; operative 3-1-89 (Register 89, No. 7).
3. Amendment of subsection (a) filed 12-18-91; operative 2-1-92 (Register 92, No. 10).
4. Amendment of subsection (a) filed 5-8-95 as an emergency; operative 5-8-95 (Register 95, No. 19). A Certificate of Compliance must be transmitted to OAL by 9-5-95 or emergency language will be repealed by operation of law on the following day.
5. Certificate of Compliance as to 5-8-95 order transmitted to OAL 8-31-95 and filed 9-25-95 (Register 95, No. 39).
6. Amendment of subsection (a) filed 2-11-97 as an emergency; operative 2-11-97 (Register 97, No. 7). A Certificate of Compliance must be transmitted to OAL by 6-11-97 or emergency language will be repealed by operation of law on the following day.
7. Certificate of Compliance as to 2-11-97 order transmitted to OAL 5-30-97 and filed 7-8-97 (Register 97, No. 28).
8. Amendment of subsection (a) filed 2-26-98 as an emergency; operative 2-26-98 (Register 98, No. 9). A Certificate of Compliance must be transmitted to OAL by 6-26-98 or emergency language will be repealed by operation of law on the following day.
9. Amendment of subsection (a) refiled 6-24-98 as an emergency; operative 6-25-98 (Register 98, No. 26). A Certificate of Compliance must be transmitted to OAL by 10-23-98 or emergency language will be repealed by operation of law on the following day.
10. Certificate of Compliance as to 6-24-98 order, including repealer and new subsection (a) and repealer of subsection (c), transmitted to OAL 10-16-98 and filed 12-2-98 (Register 98, No. 49).

**§ 3340.50.5. Suspension or Rescission of Fleet Facility License.**

(a) A fleet facility licensee shall immediately cease to test, repair, or certify vehicles whenever the facility fails to meet any of the requirements of Section 3340.50. The fleet licensee shall not resume fleet emission testing, repairing, or certification until authorized by the bureau or if suspended, until the suspension expires. The fleet facility may not resume fleet emission testing, repairing or certification until authorized by the bureau.

(b) A fleet facility license may be suspended or rescinded in accordance with Section 44020 of Chapter 5, Part 5, Division 26 of the California Health and Safety Code for any of the following acts if done by the licensee or by any licensed technician, partner, officer, or member of the licensed fleet facility.

- (1) Inspecting or testing vehicles while in violation of subsection (a) of this section.
- (2) Violation of any provision of this article.
- (3) Violation of any provision of Chapter 5, Part 5, Division 26, of the California Health and Safety Code.

**AUTHORITY:**

**Note:** Authority cited: Section 44020, Health and Safety Code. Reference: Sections 44020 and 44045.5, Health and Safety Code.

**HISTORY**

1. Amendment of subsection (b) and NOTE filed 6-23-95 as an emergency; operative 6-23-95 (Register 95, No. 25). A Certificate of Compliance must be transmitted to OAL by 10-21-95 or emergency language will be repealed by operation of law on the following day.
2. Certificate of Compliance as to 6-23-95 order transmitted to OAL 10-20-95 and filed 12-6-95 (Register 95, No. 49).

**ARTICLE 6.**

**Registration and Requirements for Automotive Repair Dealers**

- § 3350. Scope.
- § 3351. Registration of Automotive Repair Dealers.
  - § 3351.1. Fees.
  - § 3351.2. Renewal of Automotive Repair Dealer Registration.
  - § 3351.3. Display.
  - § 3351.4. Specifications for Automotive Repair Dealer's Sign.
  - § 3351.5. Equipment Requirements for Auto Body Repair Shops.
  - § 3351.6. Equipment Requirements for Automotive Air Conditioning Repair Dealers.

**§ 3350. Scope.**

**AUTHORITY:**

**Note:** Authority cited: Sections 9882 and 9884.19, Business and Professions Code.

**HISTORY**

1. New Article 6 (§§ 3350 through 3355) filed 12-29-72; effective thirtieth day thereafter (Register 72, No. 53).
2. Redesignation of Article 6 (Sections 3350-3357) to Article 6 (Sections 3351-3351.4) and repealer of Section 3350 filed 2-22-83; effective thirtieth day thereafter (Register 83, No. 9).

**§ 3351. Registration of Automotive Repair Dealers.**

An application for registration as an automotive repair dealer shall be filed on an application form prescribed and provided by the Bureau. The application shall be accompanied by the registration fee and such evidence, statements or documents as therein required. No separate registration shall be required for the mobile emergency road service or towing equipment of a registered automotive repair dealer.

**AUTHORITY:**

**Note:** Authority cited: Section 9882, Business and Professions Code. Reference: Sections 9884, 9884.1 and 9884.2, Business and Professions Code.

**HISTORY**

1. Editorial correction (Register 75, No. 4).
2. Amendment filed 7-25-75; effective thirtieth day thereafter (Register 75, No. 30).
3. New NOTE filed 2-22-83; effective thirtieth day thereafter (Register 83, No. 9).

**§ 3351.1. Fees.**

Registration fees are established as follows:

(a) Initial Registration. The initial automotive repair dealer registration fee shall be \$200.

(b) Renewal Registration. The renewal fee shall be \$200, provided that registration is renewed on or before the date of expiration. If not renewed on or before the date of expiration, the renewal fee shall be \$250 which includes a \$50 delinquency fee.

(c) Change of Ownership. A new registration shall be required of the new owner in the event of a change of



ownership, as defined in Section 3306(c)(1) of these regulations, and an application for registration accompanied by the initial registration fee in the amount of \$200 shall be submitted to the bureau for such registration.

(d) Change of Business Name, Address, and/or Corporate Officers or Directors. In the event of a change in the business name (not involving any change in ownership), corporate officers or directors, and/or business or mailing address the licensee or registrant shall submit to the bureau a Change of Name/Address/Corporate Officers or Directors, form R-8 (Rev. 05/25/01), which is hereby incorporated by reference within 14 calendar days or the license and/or registration shall cease to be valid. A replacement certificate will be issued for the balance of the unexpired term of the registration without charge. Any change in the members of a Limited Liability Company (LLC) requires a new application and fees, unless the LLC articles of incorporation expressly indicate that a change of members does not constitute a change of business.

(e) Lost, Mutilated or Destroyed Registration Certificate. A dealer shall give prompt written notice to the bureau in the event a registration certificate issued to the dealer becomes lost, mutilated, or destroyed. The dealer shall make a written request to the bureau, accompanied by a certification fee of \$2, for the issuance of a certified duplicate registration certificate for the unexpired term of the registration. Any mutilated registration certificate, and any lost registration certificate subsequently found, shall be surrendered to the bureau.

**AUTHORITY:**

**Note:** Authority cited: Sections 9882, 9884.19 and 9886.3, Business and Professions Code. Reference: Sections 163 and 9886.3, Business and Professions Code.

**HISTORY**

1. Renumbering and amendment of former section 3390 to section 3351.1 filed 2-22-83; effective thirtieth day thereafter (Register 83, No. 9).
2. Amendment of subsections (a)-(c) filed 3-11-92; operative 7-1-92 (Register 92, No. 12).
3. Amendment of subsection (d) filed 2-1-2012; operative 2-1-2012 pursuant to Government Code section 11343.4 (Register 2012, No. 5).

**§ 3351.2. Renewal of Automotive Repair Dealer Registration.**

A new registration, issued on initial application, shall expire one year from the last day of the month in which the registration was issued.

**AUTHORITY:**

**Note:** Authority cited: Section 9882, Business and Professions Code. Reference: Sections 152.5, 152.6 and 9884.3, Business and Professions Code.

**HISTORY**

1. Renumbering of former Section 3391 to Section 3351.2 filed 2-22-83; effective thirtieth day thereafter (Register 83, No. 9).
2. Change without regulatory effect repealing subsection (a) and subsection (b) designator filed 10-2-2008 pursuant to section 100, title 1, California Code of Regulations (Register 2008, No. 40).

**§ 3351.3. Display.**

(a) Except as provided in subsection (b), all automotive repair dealers shall display the following in a place and manner conspicuous to their customers:

(1) A current and valid certificate of registration as an automotive repair dealer issued by the bureau; and

(2) An official automotive repair dealer's sign, which meets the specifications of the Act and Section 3351.4 of this article. In the event there are multiple facilities, an official automotive repair dealer's sign shall be displayed in a place and manner conspicuous to all customers at each location.

(b) When conducting business from other than the principal business address shown in an automotive repair dealer's registration, the dealer shall provide to every customer, with the customer's copy of the work order as provided in paragraph (3) of subdivision (a) of Section 9884.7 of the Business and Professions Code, a copy of an official automotive repair dealer's sign that meets the following specifications:

(1) A copy of the sign shall be reproduced on a white sheet of paper, or similar material, no less than eight and one half inches by eleven inches (8 1/2" x 11") in size.

(2) The sign shall be proportionately reduced in size to fill the page in portrait format with no more than one inch (1") margins outside the right, left and bottom inset border lines.

(3) The current business name, address of record, business telephone number and registration number of the automotive repair dealer, as shown by the bureau's records, shall be printed above the top inset border line of the sign in print no smaller than the smallest print of the reduced sign.

(4) No other information, printing, decoration, border or design shall be placed on the page.

(c) For the purpose of subsection (b), the term "provide" shall mean to give for retention.

**AUTHORITY:**

**Note:** Authority cited: Section 9882, Business and Professions Code. Reference: Sections 9880.3, 9884.6 and 9884.17, Business and Professions Code.

**HISTORY**

1. Renumbering and amendment of former Section 3385 to Section 3351.3 filed 2-22-83; effective thirtieth day thereafter (Register 83, No. 9).
2. Amendment of section and Note filed 3-9-2006; operative 4-8-2006 (Register 2006, No. 10).

**§ 3351.4. Specifications for Automotive Repair Dealer's Sign.**

(a) Official automotive repair dealer signs shall meet the following specifications:

(1) Until June 30, 2006, signs shall be worded exactly as shown in either Figure 1 or Figure 3. On and after June 30, 2006, signs shall be worded exactly as shown in Figure 3, except that an automotive repair dealer possessing a valid a registration on June 30, 2006, may comply with Section 3351.3 and this section by displaying a supplementary sign, containing the bureau's Web site address. The supplementary sign shall be worded exactly as shown in Figure 5, and shall be displayed immediately below any sign that was displayed by the automotive repair dealer in compliance with Section 3351.3 and this section on and before June 30, 2006.

(2) Signs as shown in Figure 1 shall have the dimensions shown in Figure 2, signs as shown in Figure 3 shall have the dimensions shown in Figure 4, and signs as shown in Figure 5 shall have the dimensions shown in that figure.

(3) 24-gauge steel or aluminum or synthetic material of equivalent rigidity may be used. Synthetic ma-

terial may be acceptable provided it meets all of the requirements herein, including durability.

(4) The background shall be semi-gloss white. All print, border stripe and divider stripes, including the State Seal shall be gloss black in color.

(5) Paint shall be a premium grade exterior acrylic enamel or equivalent. The silk screen/bake-on process or an acceptable equivalent may be used.

(6) All bare metal shall be etched and coated with white primer or equivalent to insure proper paint adhesion and corrosion protection.

(7) Largest lettering shall be 72 pt. Futura Demi “condensed”; medium lettering shall be 48 pt. Futura Bold; and smallest lettering shall be 36 pt. Futura Bold for the signs shown in Figures 1 and 3. The lettering of the supplementary sign shown in Figure 5 shall be 48 pt. Futura Bold for the message and 72 pt. Future Demi “condensed” for the Web site address.

(8) A three and one-half inch diameter State Seal is required for the signs shown in Figures 1 and 3.

(9) The use of embossed letters or a clear protective finish coat is permitted, but not required.

(10) There shall be a one-quarter inch mounting hole in each corner.

(b) The bureau may require replacement of any sign that fails to meet the outlined specifications or that is no longer legible.

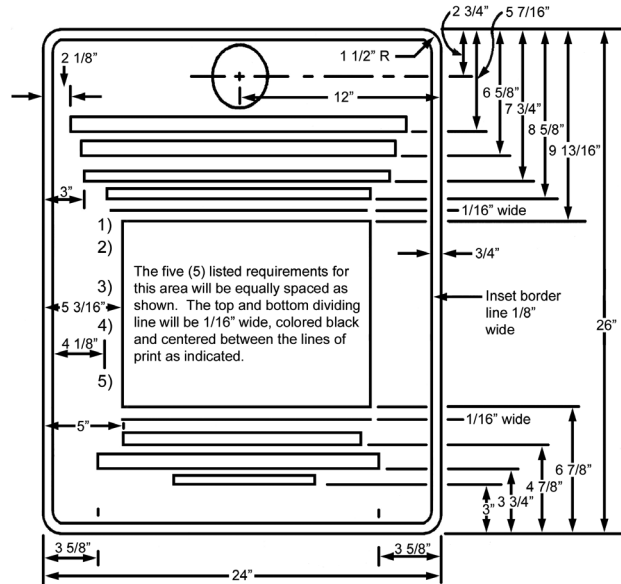

Figure 2

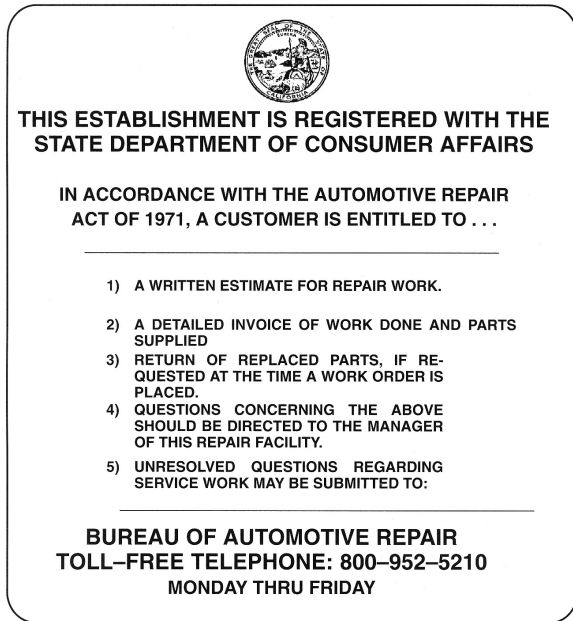

Figure 1

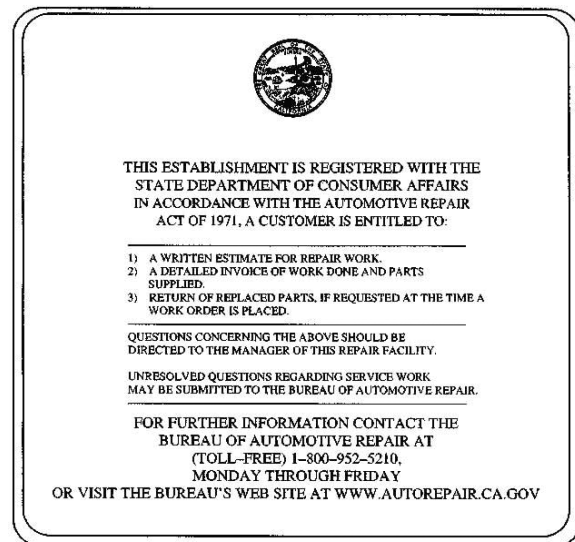

Figure 3

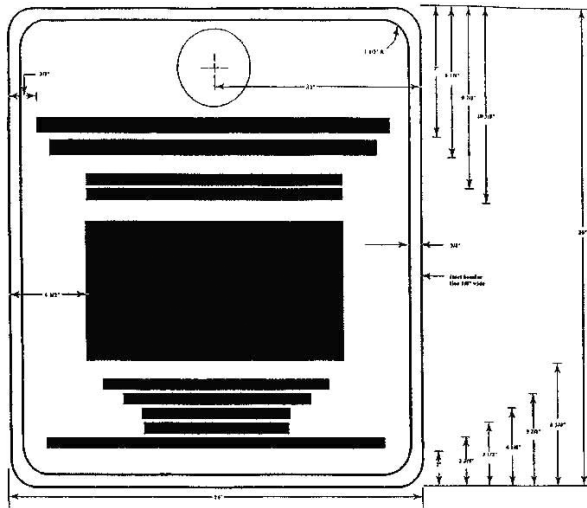

Figure 4

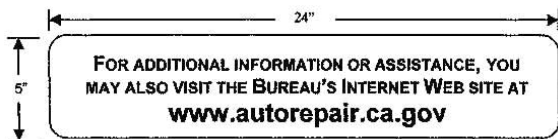

Figure 5

**AUTHORITY:**

**Note:** Authority cited: Section 9882, Business and Professions Code. Reference: Sections 9880.3 and 9884.17, Business and Professions Code.

**HISTORY**

1. Renumbering and amendment of former Section 3386 to Section 3351.4 filed 2-22-83; effective thirtieth day thereafter (Register 83, No. 9).
2. Amendment of section and Note and new Figures 3-5 filed 3-9-2006; operative 4-8-2006 (Register 2006, No. 10).
3. Editorial correction of Figure 3 (Register 2006, No. 19).

### § 3351.5. Equipment Requirements for Auto Body Repair Shops.

(a) An auto body repair shop that performs automotive painting shall have all equipment and current reference manuals necessary to paint and repair non-structural damage, including but not limited to:

- (1) corrosion protection application equipment, and
- (2) equipment capable of applying exterior corrosion resistant primers, anticorrosion compounds and top-coats.

(b) An auto body repair shop that is performing structural repairs shall have all repair, measuring, and testing equipment and current reference manuals necessary to diagnose, section, replace or repair structural damage, including but not limited to:

(1) A three dimensional measuring system that can locate points with the dimensions of length, width, and height, relative to three defined reference planes.

(2) A four-point anchoring system capable of holding a vehicle in a stationary position during structural and body pulls which is suitable for the types of vehicles being repaired.

(3) Equipment capable of making multiple body and structural pulls.

(4) A Metal Inert Gas (MIG) welder with an output of at least 110 amps for unibody repairs and an output of 200 amps for conventional frame repairs or capable of meeting trade standards for the work being performed.

(5) Corrosion protection equipment for treating enclosed areas on unibodies and frame assemblies including pressurized spray equipment, flexible and rigid wands capable of reaching full length inside enclosed areas, spray heads capable of 360 degree spray application and spray heads capable of a fan-shaped pattern.

**AUTHORITY:**

**Note:** Authority cited: Section 9882, Business and Professions Code. Reference: Sections 9889.50 and 9889.52, Business and Professions Code.

**HISTORY**

1. New section filed 10-20-97; operative 11-19-97 (Register 97, No. 43).

### § 3351.6. Equipment Requirements for Automotive Air Conditioning Repair Dealers.

All Automotive Repair Dealers engaged in the service or repair of automotive air conditioning systems in vehicles covered by the Act shall be subject to the following minimum requirements. An automotive repair dealer that is performing service or repair to a motor vehicle's air conditioning system, which involves evacuation or full or partial recharge of the air conditioning system, shall have all repair, measuring, testing and refrigerant recovery equipment and current reference manuals necessary to service or repair the system, including but not limited to:

(a) Refrigerant identification equipment that meets or exceeds current Society of Automotive Engineers (S.A.E.) standard J1771 (Rev. Nov. 1998) which is hereby incorporated by reference.

(b) Refrigerant leak detection equipment that meets or exceeds current Society of Automotive Engineers (S.A.E.) standard J1627 (Rev. Aug 1995) which is hereby incorporated by reference.

(c) Refrigerant recovery equipment that meets or exceeds current Society of Automotive Engineers (S.A.E.) standards J1732 (Rev. Nov. 1998), J1770 (Issued Oct. 1995), J1990 (Rev. Feb. 1999), J2209 (Rev. Feb. 1999) and J2210 (Rev. Feb. 1999) which are hereby incorporated by reference.

(d) Low and high pressure gauges for the purpose of measuring pressure in a mobile air conditioning system. As a minimum, the low pressure gauge shall be capable of measuring from zero to thirty inches of vacuum Hg, and zero to 250 pounds of pressure per square inch (psi). As a minimum, the high pressure gauge shall be capable of measuring from zero to 500 pounds of pressure per square inch (psi).

(e) A functioning vacuum pump that is designed for the evacuation of mobile air conditioning systems.

(f) A thermometer capable of testing air conditioning system efficiency. As a minimum, the thermometer shall be capable of measuring air temperatures from 20 to 100 degrees Fahrenheit.

**AUTHORITY:**

**Note:** Authority cited: Sections 9882 and 9884.19, Business and Professions Code. Reference: Sections 9884.7(a)(7), 9884.8 and 9884.9, Business and Professions Code.

**HISTORY**

1. New section filed 12-20-2000; operative 1-19-2001 (Register 2000, No. 51).
2. Editorial correction of subsection (c) (Register 2001, No. 17).
3. Amendment of subsections (c) and (e) filed 6-12-2003; operative 7-12-2003 (Register 2003, No. 24).

**ARTICLE 7.****Disclosure Requirements for Automotive Repair Dealers**

- § 3352. Definitions.
- § 3353. Written Estimate Required for Repair or Maintenance; Exceeding Estimate; Authorization Required.
- § 3354. Unusual Circumstances; Authorization Required.
- § 3355. Replaced Parts That Are Not Returnable.
- § 3356. Invoice Requirements.
- § 3356.1. Toxic Waste Disposal Costs.
- § 3357. Denial, Suspension, and Revocation Substantial Relation Criteria.
- § 3358. Maintenance of Records.
- § 3359. Sublet Disclosure.

**§ 3352. Definitions.**

In this article, unless the context otherwise requires:

(a) "Written estimate" means a document that contains a written estimated price for labor and parts for a specific job.

(b) "Work order" means a document that contains the estimate and memorializes the customer's authorization for a specific job.

(c) "Invoice" means a document given to the customer that meets the invoice requirements of Business and Professions Code Section 9884.8 and California Code of Regulations Section 3356.

**AUTHORITY:**

**Note:** Authority cited: Section 9882, Business and Professions Code. Reference: Sections 9884.8, 9884.9, 9889.50 and 9889.52, Business and Professions Code.

**HISTORY**

1. New section filed 10-20-97; operative 11-19-97 (Register 97, No. 43). For prior history, see Register 83, No. 9.

**§ 3353. Written Estimate Required for Repair or Maintenance; Exceeding Estimate; Authorization Required.**

No work for compensation shall be commenced and no charges shall accrue without specific authorization from the customer in accordance with the following requirements:

(a) Estimate for Parts and Labor. Every dealer shall give to each customer a written estimated price for parts and labor for a specific job.

(b) Estimate for Auto Body or Collision Repairs. Every dealer, when doing auto body or collision repairs, shall give to each customer a written estimated price for parts and labor for a specific job. Parts and labor shall be described separately and each part shall be identified, indicating whether the replacement part is new, used, rebuilt, or reconditioned. The estimate shall also describe replacement crash parts as original equipment manufacturer (OEM) crash parts or non-OEM aftermarket crash parts.

(c) Additional Authorization. Except as provided in subsection (f), the dealer shall obtain the customer's authorization before any additional work not estimated is done or parts not estimated are supplied. This autho-

ization shall be in written, oral, or electronic form, and shall describe the additional repairs, parts, labor and the total additional cost.

(1) If the authorization from the customer for additional repairs, parts, or labor in excess of the written estimated price is obtained orally, the dealer shall also make a notation on the work order and on the invoice of the date, time, name of the person authorizing the additional repairs, and the telephone number called, if any, together with the specification of the additional repairs, parts, labor and the total additional cost.

(2) If the authorization from the customer for additional repairs, parts, or labor in excess of the written estimated price is obtained by facsimile transmission (fax), the dealer shall also attach to the work order and the invoice, a faxed document that is signed and dated by the customer and shows the date and time of transmission and describes the additional repairs, parts, labor and the total additional cost.

(3) If the authorization from the customer for additional repairs, parts, or labor in excess of the written estimated price is obtained by electronic mail (e-mail), the dealer shall print and attach to the work order and invoice, the e-mail authorization which shows the date and time of transmission and describes the additional repairs, parts, labor and the total additional cost.

(4) The additional repairs, parts, labor, total additional cost, and a statement that the additional repairs were authorized either orally, or by fax, or by e-mail shall be recorded on the final invoice pursuant to Section 9884.9 of the Business and Professions Code. All documentation must be retained pursuant to Section 9884.11 of the Business and Professions Code.

(d) Estimated Price to Tear Down, Inspect, Report and Reassemble. For purposes of this article, to "tear down" shall mean to disassemble, and "teardown" shall mean the act of disassembly. If it is necessary to tear down a vehicle component in order to prepare a written estimated price for required repair, the dealer shall first give the customer a written estimated price for the teardown. This price shall include the cost of reassembly of the component. The estimated price shall also include the cost of parts and necessary labor to replace items such as gaskets, seals and O rings that are normally destroyed by teardown of the component. If the act of teardown might prevent the restoration of the component to its former condition, the dealer shall write that information on the work order containing the teardown estimate before the work order is signed by the customer.

The repair dealer shall notify the customer orally and conspicuously in writing on the teardown estimate the maximum time it will take the repair dealer to reassemble the vehicle or the vehicle component in the event the customer elects not to proceed with the repair or maintenance of the vehicle and shall reassemble the vehicle within that time period if the customer elects not to proceed with the repair or maintenance. The maximum time shall be counted from the date of authorization of teardown.

After the teardown has been performed, the dealer shall prepare a written estimated price for labor and parts necessary for the required repair. All parts required for such repair shall be listed on the estimate.

The dealer shall then obtain the customer's authorization for either repair or reassembly before any further work is done.

(e) **Revising an Itemized Work Order.** If the customer has authorized repairs according to a work order on which parts and labor are itemized, the dealer shall not change the method of repair or parts supplied without the written, oral, or electronic authorization of the customer. The authorization shall be obtained from the customer as provided in subsection (c) and Section 9884.9 of the Business and Professions Code.

(f) **Designation of Person to Authorize Additional Work or Parts.** When a customer, pursuant to subdivision (d) of Section 9884.9 of the Business and Professions Code, designates another person to authorize work not estimated or parts not included in the written estimated price given to the customer, all of the following shall apply:

(1) The designation may be a separate form by itself or may be incorporated into the dealer's work order form described in subsection (b) of Section 3352.

(2) If a separate form is used for the designation, the form and content of the designation shall be as follows:

"DESIGNATION OF PERSON TO AUTHORIZE  
ADDITIONAL WORK OR PARTS

I hereby designate the individual named below to authorize any additional work not specified or parts not included in the original written estimated price for parts and labor:

Name of Designee: \_\_\_\_\_  
 Phone Number: \_\_\_\_\_  
 Fax Number: \_\_\_\_\_  
 E-Mail Address: \_\_\_\_\_  
 Name of Customer: \_\_\_\_\_  
 Work Order No.: \_\_\_\_\_  
 Date: \_\_\_\_\_

\_\_\_\_\_  
 (Customer's Signature)"

(3) If the designation is incorporated into a work order form, it need only separately include the designation statement specified in paragraph (2) of this subsection, and the name, phone number, facsimile number and e-mail address of the designee, and the customer's signature, and the date of signing.

(4) The dealer shall not accept from the customer the designation of any person or entity not eligible to be a designee under subdivision (d) of Section 9884.9 of the Business and Professions Code. The ineligible designees include the automotive repair dealer providing repair services and an insurer involved in a claim that includes the motor vehicle being repaired, and employees and agents and persons acting on behalf of the dealer or insurer.

(5) The designation form shall be completed in duplicate and shall be distributed as follows:

(A) The copy of the completed and signed designation form shall be given to the customer with the customer's copy of the work order as required by paragraph (3) of subdivision (a) of Section 9884.7 of the Business and Professions Code.

(B) The original of the completed and signed designation form shall be attached to the dealer's copy of the work order, if not incorporated therein, and shall be retained pursuant to Section 9884.11 of the Business and Professions Code and Section 3358.

(6) When authorization for additional work or parts not estimated is obtained from a designee, it shall be obtained and recorded in compliance with subsection (c) of this section before any additional work not estimated is done or parts not estimated are supplied.

(g) **Unusual Circumstances; Authorization Required.** When the customer is unable to deliver the motor vehicle to the dealer during business hours or if the motor vehicle is towed to the dealer without the customer during business hours, and the customer has requested the dealer to take possession of the motor vehicle for the purpose of repairing or estimating the cost of repairing the motor vehicle, the dealer shall not undertake the diagnosing or repairing of any malfunction of the motor vehicle for compensation unless the dealer has complied with all of the following conditions:

(1) The dealer has prepared a work order stating the written estimated price for labor and parts, as specified in subsection (a) or (b), necessary to repair the motor vehicle; and

(2) By telephone, fax or e-mail, the customer has been given all of the information on the work order and the customer has approved the work order; and

(3) The customer has given oral, written or electronic authorization to the dealer to make the repairs and the dealer has documented the authorization as provided in subsection (c) and Section 9884.9 of the Business and Professions Code.

Any charge for parts or labor in excess of the original written estimated price must be separately authorized by the customer and documented by the dealer, as provided in subsection (c) and Section 9884.9 of the Business and Professions Code.

(h) **Definitions.** As used in this section, "written" shall mean the communication of information in writing, other than by electronic means; "oral" shall mean the oral communication of information either in person or telephonically; "electronic" shall mean the communication of information by facsimile transmission (fax) or electronic mail (e-mail).

**AUTHORITY:**

**Note:** Authority cited: Sections 9882 and 9884.9, Business and Professions Code. Reference: Sections 9884.8, 9884.9, 9889.50 and 9889.52, Business and Professions Code.

**HISTORY**

1. Amendment filed 6-26-74; designated effective 8-1-74 (Register 74, No. 26).

2. Amendment of subsection (b) and new subsection (c) filed 6-9-78; effective thirtieth day thereafter (Register 78, No. 23).

3. Repealer and new section filed 10-27-82; effective thirtieth day thereafter (Register 82, No. 44).

4. Redesignation of former Article 7 (Section 3365) to new Article 7 (Sections 3353-3358) filed 2-22-83; effective thirtieth day thereafter (Register 83, No. 9).

5. Amendment of subsections (d) and (d)(1) filed 5-9-96; operative 6-8-96 (Register 96, No. 19).

6. Amendment of subsection (a) and Note filed 10-20-97; operative 11-19-97 (Register 97, No. 43).

7. Amendment of section and Note filed 5-2-2002; operative 6-1-2002 (Register 2002, No. 18).

8. Amendment of subsection (c), new subsections (f)-(f)(6), subsection relettering and amendment of newly designated subsection (g) filed 4-17-2006; operative 5-17-2006 (Register 2006, No. 16).

**§ 3354. Unusual Circumstances; Authorization Required.**

**HISTORY**

1. Amendment filed 7-25-75; effective thirtieth day thereafter (Register 75, No. 30).
2. Repealer filed 10-27-82; effective thirtieth day thereafter (Register 82, No. 44).

**§ 3355. Replaced Parts That Are Not Returnable.**

Those parts and components that are replaced and that are sold on an exchange basis are exempt from the provisions of Section 9884.10 of the Act requiring the return of replaced parts to the customer, provided the customer is informed that said parts are not returnable orally and by written record on the work order and invoice. When a request is made before the work is started, the dealer shall provide a reasonable opportunity to the customer to inspect the part.

**AUTHORITY:**

**Note:** Authority cited: Section 9882, Business and Professions Code. Reference: Section 9884.10, Business and Professions Code.

**HISTORY**

1. Amendment filed 2-22-83; effective thirtieth day thereafter (Register 83, No. 9).

**§ 3356. Invoice Requirements.**

(a) All invoices for service and repair work performed, and parts supplied, as provided for in Section 9884.8 of the Business and Professions Code, shall comply with the following:

(1) The invoice shall show the automotive repair dealer's registration number and the corresponding business name and address as shown in the Bureau's records. If the automotive repair dealer's telephone number is shown, it shall comply with the requirements of subsection (b) of Section 3371 of this chapter.

(2) The invoice shall separately list, describe and identify all of the following:

(A) All service and repair work performed, including all diagnostic and warranty work, and the price for each described service and repair.

(B) Each part supplied, in such a manner that the customer can understand what was purchased, and the price for each described part. The description of each part shall state whether the part was new, used, reconditioned, rebuilt, or an OEM crash part, or a non-OEM aftermarket crash part.

(C) The subtotal price for all service and repair work performed.

(D) The subtotal price for all parts supplied, not including sales tax.

(E) The applicable sales tax, if any.

(b) If a customer is to be charged for a part, that part shall be specifically listed as an item in the invoice, as provided in subparagraph (B) of paragraph (2) of subsection (a) above. If that item is not listed in the invoice, it shall not be regarded as a part, and a separate charge may not be made for it.

(c) Separate billing in an invoice for items generically noted as shop supplies, miscellaneous parts, or the like, is prohibited.

(d) The automotive repair dealer shall give the customer a legible copy of the invoice and shall retain a legible copy as part of the automotive repair dealer's records pursuant to Section 9884.11 of the Business and Professions Code and Section 3358 of this article.

**AUTHORITY:**

**Note:** Authority cited: Sections 137 and 9882, Business and Professions Code. Reference: Sections 9884.8, 9889.50 and 9889.52, Business and Professions Code; and Sections 12000 and 12001, Vehicle Code.

**HISTORY**

1. New section filed 6-26-74; designated effective 8-1-74 (Register 74, No. 26).
2. Amendment filed 12-23-76; effective thirtieth day thereafter (Register 76, No. 52).
3. Amendment filed 6-9-78; effective thirtieth day thereafter (Register 78, No. 23).
4. Amendment of Note filed 2-22-83; effective thirtieth day thereafter (Register 83, No. 9).
5. Amendment of section filed 8-20-91; operative 9-19-91 (Register 92, No. 1).
6. Amendment of subsection (a) and Note filed 10-20-97; operative 11-19-97 (Register 97, No. 43).
7. Repealer and new section filed 2-2-2007; operative 3-4-2007 (Register 2007, No. 5).

**§ 3356.1. Toxic Waste Disposal Costs.**

An automotive repair dealer may charge a customer for costs associated with the handling, management and disposal of toxic wastes or hazardous substances under California or federal law which directly relate to the servicing or repair of the customer's vehicle. Such charge must be disclosed to the customer by being separately itemized on the estimate prepared pursuant to Section 9884.9(a) of the Business and Professions Code and on the invoice prepared pursuant to Section 9884.8 of the Business and Professions Code. In order to assess this charge, the automotive repair dealer must note on the estimate and invoice the station's Environmental Protection Agency identification number required by Section 262.12 of Title 40 of the Code of Federal Regulations.

**AUTHORITY:**

**Note:** Authority cited: Section 9882, Business and Professions Code. Reference: Sections 9882, 9884.8, and 9884.9(a), Business and Professions Code.

**HISTORY**

1. New section filed 8-20-91; operative 9-19-91 (Register 92, No. 1).

**§ 3357. Denial, Suspension, and Revocation Substantial Relation Criteria.**

**AUTHORITY:**

**Note:** Authority cited: Sections 9882 and 9884.19, Business and Professions Code. Reference: Sections 475 et seq. of Division 1.5, Business and Professions Code.

**HISTORY**

1. New section filed 5-8-75; effective thirtieth day thereafter (Register 75, No. 19).
2. Amendment filed 12-23-76; effective thirtieth day thereafter (Register 76, No. 52).
3. Renumbering and amendment of Section 3357 to Section 3395.2 filed 2-22-83; effective thirtieth day thereafter (Register 83, No. 9).

### § 3358. Maintenance of Records.

Each automotive repair dealer shall maintain legible copies of the following records for not less than three years:

(a) All invoices relating to automotive repair including invoices received from other sources for parts and/or labor.

(b) All written estimates pertaining to work performed.

(c) All work orders and/or contracts for repairs, parts and labor. All such records shall be open for reasonable inspection and/or reproduction by the bureau or other law enforcement officials during normal business hours.

#### AUTHORITY:

**Note:** Authority cited: Sections 9882 and 9884.11, Business and Professions Code. Reference: Section 9884.11, Business and Professions Code.

#### HISTORY

1. Renumbering of former Section 3365 to Section 3358 filed 2-22-83; effective thirtieth day thereafter (Register 83, No. 9).

### § 3359. Sublet Disclosure.

Upon the request of a customer, an automotive repair dealer shall disclose the location at which any repair work will be done other than repair work to be done at the dealer's location and by the dealer or his/her employees

#### AUTHORITY:

**Note:** Authority cited: Section 9882, Business and Professions Code. Reference: Sections 9882 and 9884.7, Business and Professions Code.

#### HISTORY

1. New section filed 4-16-90; operative 4-16-90 (Register 90, No. 19).

## ARTICLE 8. Accepted Trade Standards

§ 3360.	Scope of Regulations.
§ 3360.1.	Ball Joints.
§ 3360.2.	General Requirements.
§ 3360.3.	Recommendations Permitted.
§ 3361.1.	Automatic Transmissions.
§ 3362.1.	Engine Changes.
§ 3363.1.	Ignition Interlock Devices.
§ 3363.2.	Ignition Interlock Device Manufacturer's Responsibilities.
§ 3363.3.	Authorized Installers of Ignition Interlock Devices.
§ 3363.4.	Installation Standards Applicable to Ignition Interlock Devices.
§ 3364.	Vehicle Identification Information.
§ 3365.	Auto Body and Frame Repairs.
§ 3366.	Automotive Air Conditioning.
§ 3367.	Inflatable Restraint Systems; Airbags.
§ 3368.	Commissions, Consideration, Inducements, or Referral Fees; Towing Services.

### § 3360. Scope of Regulations.

This article shall apply to accepted trade standards for good and workmanlike automotive repair as performed by automotive repair dealers.

#### AUTHORITY:

**Note:** Authority cited: Sections 9882 and 9884.19, Business and Professions Code. Reference: Sections 9884.7 and 9884.19, Business and Professions Code.

#### HISTORY

1. New Article 6.5 (Sections 3360-3360.3) filed 3-6-75; effective thirtieth day thereafter (Register 75, No. 10).  
2. Amendment filed 12-23-76; effective thirtieth day thereafter (Register 76, No. 52).

3. Renumbering of former Article 6.5 (Sections 3360-3361.1) to new Article 8 (Sections 3360-3361.1), and amendment of Section 3360 NOTE filed 2-22-83; effective thirtieth day thereafter (Register 83, No. 9).

### § 3360.1. Ball Joints.

This section and Sections 3360.2 and 3360.3 apply to the inspection, sale, and installation of ball joints, which for the purpose of this article are defined as ball-and-socket assemblies designed to carry the vertical and horizontal stresses in the front suspension system of a motor vehicle while permitting steering and suspension movement.

#### AUTHORITY:

**Note:** Authority cited: Sections 9882 and 9884.19, Business and Professions Code. Reference: Sections 9884.7 and 9884.19, Business and Professions Code.

#### HISTORY

1. Amendment filed 12-23-76; effective thirtieth day thereafter (Register 76, No. 52).  
2. Amendment of section title filed 6-9-78; effective thirtieth day thereafter (Register 78, No. 23).  
3. New NOTE filed 2-22-83; effective thirtieth day thereafter (Register 83, No. 9).

### § 3360.2. General Requirements.

All automotive repair dealers engaged in the sale and installation of ball joints shall be subject to the following requirements:

(a) Measurement of Wear or Looseness. Except as set forth in (e) and (f) of this section, any determination that a ball joint is worn or loose shall be made with an instrument specifically designed and manufactured for measurement of ball joint wear or looseness.

(b) Care and Use of Instrument. The instrument required by (a) of this section shall be used, calibrated, and maintained in accordance with the instructions issued by its manufacturer. The manufacturer shall be the original equipment manufacturer or a manufacturer who is generally known within the automotive repair industry as a supplier of such instruments.

(c) Accuracy of Measurement. The measurement of wear or looseness of a ball joint shall be stated in thousandths of an inch (.001) or in millimeters, whichever is appropriate to the vehicle and to the specifications of the original equipment manufacturer or of the replacement parts manufacturer.

(d) Invoice Requirements. If a ball joint is sold and installed, the degree of wear or looseness of the ball joint being replaced must be recorded on the customer's invoice in accordance with (c) of this section. The maximum allowable wear or looseness permitted by the original equipment manufacturer or by the replacement parts manufacturer must be stated.

(e) Measurement of Wear-Indicating Ball Joints. If a ball joint is equipped with an integral means of measuring wear or looseness, such measurement shall be made and reported in accordance with the manufacturer's directions.

(f) Adjustment of Mechanically Adjustable Ball Joints. A ball joint that has been manufactured with a means of manual adjustment to compensate for wear shall be adjusted in accordance with the instructions of the manufacturer.

**Note:** Authority cited: Sections 9882 and 9884.19, Business and Professions Code. Reference: Sections 9884.7 and 9884.19, Business and Professions Code.

**HISTORY**

1. New NOTE filed 2-22-83; effective thirtieth day thereafter (Register 83, No. 9).

**§ 3360.3. Recommendations Permitted.**

The foregoing requirements are not to be construed as prohibiting the sale and installation of ball joints when the sale and installation are made with the consent of the customer, provided that a full disclosure of the requirements of this article is made to the customer.

**AUTHORITY:**

**Note:** Authority cited: Sections 9882 and 9884.19, Business and Professions Code. Reference: Sections 9884.7 and 9884.19, Business and Professions Code.

**HISTORY**

1. New NOTE filed 2-22-83; effective thirtieth day thereafter (Register 83, No. 9).

**§ 3361.1. Automatic Transmissions.**

The following minimum requirements specifying accepted trade standards for good and workmanlike rebuilding of automatic transmissions are intended to define terms that have caused confusion to the public and unfair competition within the automotive repair industry. The term "automatic transmission" shall also apply to the automatic transmission portion of transaxles for the purposes of this regulation, unless both the automatic transmission portion and the differential portion of the transaxle share a common oil supply, in which case the term "automatic transmission" shall apply to both portions of the transaxle. These minimum requirements shall not be used to promote the sale of "rebuilt" automatic transmissions when a less extensive and/or less costly repair is desired by the customer. Any automotive repair dealer who represents to customers that the following sections require the rebuilding of automatic transmissions is subject to the sanctions prescribed by the Automotive Repair Act. All automotive repair dealers engaged in the repair, sale, or installation of automatic transmissions in vehicles covered under the Act shall be subject to the following minimum requirements:

(a) Before an automatic transmission is removed from a motor vehicle for purposes of repair or rebuilding, it shall be inspected. Such inspection shall determine whether or not the replacement or adjustment of any external part or parts will correct the specific malfunction of the automatic transmission. In the case of an electronically controlled automatic transmission, this inspection shall include a diagnostic check, including the retrieval of any diagnostic trouble codes, of the electronic control module that controls the operation of the transmission. If minor service and/or replacement or adjustment of any external part or parts and/or of companion units can reasonably be expected to correct the specific malfunction of the automatic transmission, then prior to removal of the automatic transmission from the vehicle, the customer shall be informed of that fact as required by Section 3353 of these regulations. Before removing an automatic transmission from a motor vehicle, the dealer shall also comply with the provisions of section 3353(d), and disclose any applicable guarantee or warranty as provided in sections 3375, 3376 and 3377 of these regulations. If a diagnostic check of an electronic control module cannot be completed due to the condition of the transmission,

the customer shall be informed of that fact and a notation shall be made on the estimate, in accordance with Section 3353 of these regulations.

(b) When the word "exchanged" is used to describe an automatic transmission, it shall mean that the automatic transmission is not the customer's unit that was removed from the customer's vehicle. Whenever the word "exchanged" is used to describe an automatic transmission, it shall be accompanied by a word or descriptive term such as "new," "used," rebuilt," "remanufactured," "reconditioned," or "overhauled," or by an expression of like meaning.

(c) Any automotive repair dealer that advertises or performs, directly or through a sublet contractor, automatic transmission work and uses the words "exchanged," "rebuilt," "remanufactured," "reconditioned," or "overhauled," or any expression of like meaning, to describe an automatic transmission in any form of advertising or on a written estimate or invoice shall only do so when all of the following work has been done since the transmission was last used:

(1) All internal and external parts, including case and housing, have been thoroughly cleaned and inspected.

(2) The valve body has been disassembled and thoroughly cleaned and inspected unless otherwise specified by the manufacturer.

(3) All bands have been replaced with new or relined bands.

(4) All the following parts have been replaced with new parts:

(A) Lined friction plates

(B) Internal and external seals including seals that are bonded to metal parts

(C) All sealing rings

(D) Gaskets

(E) Organic media disposable type filters (if the transmission is so equipped) (5) All impaired, defective, or substantially worn parts not mentioned above have been restored to a sound condition or replaced with new, rebuilt, or unimpaired parts. All measuring and adjusting of such parts has been performed as necessary.

(5) All impaired, defective, or substantially worn parts not mentioned above have been restored to a sound condition or replaced with new, rebuilt, or unimpaired parts. All measuring and adjusting of such parts has been performed as necessary.

(6) The transmission's electronic components, if so equipped, have been inspected and found to be functioning properly or have been replaced with new, rebuilt, or unimpaired components that function properly.

(7) The torque converter has been inspected and serviced in accordance with subsection (d) of this regulation.

(d) The torque converter is considered to be part of the automatic transmission and shall be examined, cleaned, and made serviceable before the rebuilt, remanufactured or overhauled transmission is installed. If the torque converter cannot be restored to a serviceable condition, then the customer shall be so informed. With the customer's authorization, the converter shall be replaced with a new, rebuilt, remanufactured, reconditioned, overhauled, or unimpaired used torque converter. A torque converter shall not be represented as rebuilt, re-



manufactured, reconditioned, or overhauled unless the torque converter shell has been opened, all components of the overrunning clutch assembly have been inspected and replaced as required, all friction materials have been replaced as required, all rotating parts have been examined and replaced as required, the shell has been resealed, and the unit has been pressure tested.

**AUTHORITY:**

**Note:** Authority cited: Sections 9882 and 9884.19, Business and Professions Code. Reference: Sections 9884.7(a), 9884.8, 9884.9(a) and 9884.19, Business and Professions Code.

**HISTORY**

1. New section filed 6-9-78; effective thirtieth day thereafter (Register 78, No. 23).
2. Amendment of subsection (c) and new subsections (d) and (e) filed 10-27-82; effective thirtieth day thereafter (Register 82, No. 44).
3. Editorial correction of subsection (a) filed 2-22-83 (Register 83, No. 9).
4. Amendment of section and Note filed 2-13-2002; operative 3-15-2002 (Register 2002, No. 7).
5. Amendment of subsection (a) filed 5-2-2002; operative 6-1-2002 (Register 2002, No. 18).

**§ 3362.1. Engine Changes.**

An automotive repair dealer shall not make any motor vehicle engine change that degrades the effectiveness of a vehicle's emission control system. Nor shall said dealer, in the process of rebuilding the original engine or while installing a replacement engine, effect changes that would degrade the effectiveness of the original emission control system and/or components thereof.

**AUTHORITY:**

**Note:** Authority cited: Sections 9882, 9884.7 and 9884.19, Business and Professions Code. Reference: Sections 9884.7 and 9884.19, Business and Professions Code; and Sections 4000.1, 4000.2, 4000.3 and 27156, Vehicle Code.

**HISTORY**

1. New section filed 8-24-88; operative 9-23-88 (Register 88, No. 37).
2. Amendment of section filed 8-20-91; operative 9-19-91 (Register 92, No. 1).

**§ 3363.1. Ignition Interlock Devices.**

Ignition interlock device standards apply to the installation of vehicular electrical devices that measure a motorist's breath sample for alcohol content, and, on the basis of that measurement, allow or not allow the vehicle's starter to be energized.

**AUTHORITY:**

**Note:** Authority cited: Sections 9882 and 9882.14, Business and Professions Code. Reference: Section 23244, Vehicle Code; and Section 9882.14, Business and Professions Code.

**HISTORY**

1. New section filed 1-26-89; operative 2-25-89 (Register 89, No. 7).

**§ 3363.2. Ignition Interlock Device Manufacturer's Responsibilities.**

The manufacturer of an ignition interlock device shall develop detailed written instructions regarding the installation of the device. Such instructions shall be in accordance with the guidelines adopted by the Office of Traffic Safety (OTS) pursuant to Section 23244(b) of the Vehicle Code.

**AUTHORITY:**

**Note:** Authority cited: Sections 9882 and 9882.14, Business and Professions Code. Reference: Section 23244, Vehicle Code; and Section 9882.14, Business and Professions Code.

**HISTORY**

1. New section filed 1-26-89; operative 2-25-89 (Register 89, No. 7).

**§ 3363.3. Authorized Installers of Ignition Interlock Devices.**

Only an automotive repair dealer, as defined by Sections 9880.1 and 9884.6 of the Business and Professions Code, may install an ignition interlock device.

**AUTHORITY:**

**Note:** Authority cited: Sections 9882 and 9882.14, Business and Professions Code. Reference: Section 23244, Vehicle Code; and Sections 9880.1, 9882, 9882.14 and 9884.6, Business and Professions Code.

**HISTORY**

1. New section filed 1-26-89; operative 2-25-89 (Register 89, No. 7).

**§ 3363.4. Installation Standards Applicable to Ignition Interlock Devices.**

An automotive repair dealer who installs ignition interlock devices in vehicles shall comply with the following conditions:

(a) Not allow customers or other unauthorized persons to observe installation of the devices.

(b) Have all tools, test equipment and manuals needed to install devices and needed to screen vehicles for acceptable mechanical and electrical condition prior to installation. These include, but are not necessarily limited to, the following:

(1) Tools to make electrical connections in a competent manner (properly soldered, or mechanically crimped with high quality connectors) and in accordance with accepted trade standards.

(2) Heat gun if heat shrink tubing or heat set labels are used.

(3) Volt/ohmmeter.

(4) Test light.

(5) Battery testing equipment and servicing tools (load tester, terminal cleaning tools, and battery filler).

(6) Electrical wiring diagrams and/or reference guide for electrical systems on import and domestic vehicles, 20 years old or less, necessary for the installation and operation of the device.

(7) Tools and equipment listed by the device manufacturer to properly install devices in accordance with guidelines adopted by the Office of Traffic Safety (OTS) pursuant to Section 23244(b) of the Vehicle Code.

(c) Provide adequate security measures to prevent unauthorized persons from accessing secured materials (tamper seals or installation instructions).

(d) Appropriately install devices on vehicles taking into account each vehicle's mechanical and electrical condition, following accepted trade standards and the device manufacturer's instructions, and correcting conditions (such as low battery or alternator voltage, or engine stalling frequent enough to require additional breath tests) which interfere with the proper functioning of the device.

(e) Not install devices in a manner that could adversely affect the performance of the device or impede the safe operation of the vehicle.

(f) Verify that a device is functioning properly after it has been installed in the vehicle.

(g) Restore a vehicle to its original condition when a device is removed. All severed wires must be permanently reconnected and insulated with heat shrink tubing or equivalent.

**AUTHORITY:**

**Note:** Authority cited: Sections 9882 and 9882.14, Business and Professions Code. Reference: Section 23244, Vehicle Code; and Section 9882.14, Business and Professions Code.

**HISTORY**

1. New section filed 1-26-89; operative 2-25-89 (Register 89, No. 7).

**§ 3364. Vehicle Identification Information.**

(a) An automotive repair dealer shall not remove, paint over, or otherwise deface any label or sticker which has been affixed to the doorpost, dash, underhood, windshield, or other location on a vehicle, and which contains identifying information regarding the vehicle or its emission control system components. An automotive repair dealer shall replace any such label or sticker which would otherwise be destroyed as part of the repair process, unless the replacement label or sticker is not reasonably available.

(b) The above requirements shall apply to any label or sticker mandated by the bureau or other governmental agency as well as those included with the vehicle as part of its original manufacture and those added onto a vehicle as part of a manufacturer's authorized recall program.

**AUTHORITY:**

**Note:** Authority cited: Sections 9882 and 9884.19, Business and Professions Code. Reference: Sections 9884.7 and 9884.19, Business and Professions Code.

**HISTORY**

1. New section filed 10-23-91; operative 11-22-91 (Register 92, No. 35).

**§ 3365. Auto Body and Frame Repairs.**

The accepted trade standards for good and workmanlike auto body and frame repairs shall include, but not be limited to, the following:

(a) Repair procedures including but not limited to the sectioning of component parts, shall be performed in accordance with OEM service specifications or nationally distributed and periodically updated service specifications that are generally accepted by the autobody repair industry.

(b) All corrosion protection shall be applied in accordance with manufacturers' specifications or nationally distributed and periodically updated service specifications that are generally accepted by the autobody repair industry.

**AUTHORITY:**

**Note:** Authority cited: Sections 9882 and 9884.19, Business and Professions Code. Reference: Sections 9884.7, 9889.50 and 9889.52, Business and Professions Code.

**HISTORY**

1. New section filed 10-20-97; operative 11-19-97 (Register 97, No. 43). For prior history, see Register 83, No. 9.

**§ 3366. Automotive Air Conditioning.**

(a) Except as provided in subsection (b) of this section, any automotive repair dealer that advertises or performs, directly or through a sublet contractor, automotive air conditioning work and uses the words service, inspection, diagnosis, top off, performance check or any expression or term of like meaning in any form of advertising or on a written estimate or invoice shall include and perform all of the following procedures as part of that air conditioning work:

(1) Exposed hoses, tubing and connections are examined for damage or leaks;

(2) The compressor and clutch, when accessible, are examined for damage, missing bolts, missing hardware, broken housing and leaks;

(3) The compressor is rotated to determine if it is seized or locked up;

(4) Service ports are examined for missing caps, damaged threads and conformance with labeling;

(5) The condenser coil is examined for damage, restrictions or leaks;

(6) The expansion device, if accessible, is examined for physical damage or leaks;

(7) The accumulator receiver dryer and in-line filter have been checked for damage, missing or loose hardware or leaks;

(8) The drive belt system has been checked for damaged or missing pulleys or tensioners and for proper belt routing, tension, alignment, excessive wear or cracking;

(9) The fan clutch has been examined for leakage, bearing wear and proper operation;

(10) The cooling fan has been checked for bent or missing blades;

(11) Accessible electrical connections have been examined for loose, burnt, broken or corroded parts;

(12) The refrigerant in use has been identified and checked for contamination;

(13) The system has been checked for leakage at a minimum of 50-PSI system pressure;

(14) The compressor clutch, blower motor and air control doors have been checked for proper operation;

(15) High and low side system operating pressures, as applicable, have been measured and recorded on the final invoice; and,

(16) The center air distribution outlet temperature has been measured and recorded on the final invoice.

(b) Whenever the automotive air conditioning work being advertised or performed does not involve opening the refrigerant portion of the air conditioning system, refrigerant evacuation, or full or partial refrigerant recharge, the procedures specified in subsection (a) need be performed only to the extent required by accepted trade standards.

**AUTHORITY:**

**Note:** Authority cited: Sections 9882 and 9884.19, Business and Professions Code. Reference: Sections 9884.7(a)(7), 9884.8 and 9884.9, Business and Professions Code.

**HISTORY**

1. New section filed 12-20-2000; operative 1-19-2001 (Register 2000, No. 51).

2. Amendment filed 6-12-2003; operative 7-12-2003 (Register 2003, No. 24).

**§ 3367. Inflatable Restraint Systems; Airbags.**

(a) An Automobile Repair Dealer shall not install or reinstall, or distribute or sell, any air bag which is known, or which by the exercise of reasonable care should be known, to have been previously deployed, and which is part of an inflatable restraint system.

(b) Any violation of this section shall be cause for administrative disciplinary action. The authority of the bureau to impose discipline pursuant to this section shall be in addition to, and not a limitation on, its authority to take disciplinary action or other legal action, pursuant to any other provision of law.

**AUTHORITY:**

**Note:** Authority cited: Sections 9882 and 9884.19, Business and Professions Code. Reference: Sections 490 and 9884.7, Business and Professions Code; and Section 27317, Vehicle Code.

**HISTORY**

1. New section filed 8-1-2002; operative 8-31-2002 (Register 2002, No. 31).

**§ 3368. Commissions, Consideration, Inducements, or Referral Fees; Towing Services.**

(a) An Automobile Repair Dealer shall not directly or indirectly pay or agree to pay any money or anything of value as a commission, referral fee, inducement, or in any manner a consideration, to a towing service for the delivery or the arranging of a delivery of a vehicle not owned by the repair shop or towing service, for the purpose of storage or repair.

(b) An Automobile Repair Dealer shall not directly or indirectly accept or agree to accept any money or anything of value as a commission, referral fee, inducement or in any manner a consideration, from a towing service for arranging or requesting the services of a tow truck.

(c) Any violation of this section shall be cause for administrative disciplinary action. The authority of the bureau to impose discipline pursuant to this section shall be in addition to, and not a limitation on, its authority to take disciplinary action or other legal action, pursuant to any other provision of law.

**AUTHORITY:**

**Note:** Authority cited: Sections 9882 and 9884.19, Business and Professions Code. Reference: Sections 490 and 9884.7, Business and Professions Code; and Section 12110, Vehicle Code.

**HISTORY**

1. New section filed 8-1-2002; operative 8-31-2002 (Register 2002, No. 31).

**ARTICLE 9.****False or Misleading Statements and Advertising**

§ 3370.	Application of Article.
§ 3371.	Untrue or Misleading Statements or Advertising.
§ 3371.1.	Presumption As Automotive Repair Dealer.
§ 3372.	False or Misleading Defined.
§ 3372.1.	Price Advertising.
§ 3373.	False or Misleading Records.
§ 3374.	New, Rebuilt, Reconditioned, or Used Parts and Components.
§ 3374.1.	Manufacture, Sale, or Installation of Defective Vehicle Parts.
§ 3375.	Guarantees and Warranties.
§ 3376.	Disclosure of Guarantee.
§ 3377.	Pro-Rata Guarantee.
§ 3385.	Display.
§ 3386.	Specifications for Automotive Repair Dealer's Sign.
§ 3390.	Fees.

§ 3391. Renewal of Automotive Repair Dealer Registration.

**§ 3370. Application of Article.**

For the purposes of Sections 9882 and 9884.19 of the Act, false or misleading advertising includes but is not limited to advertising, within the meaning of Section 17500 of the Business and Professions Code, which violates any provision of this article.

**AUTHORITY:**

**Note:** Authority cited: Sections 9882 and 9884.19, Business and Professions Code. Reference: Sections 9884.7, 9884.19 and 17500, Business and Professions Code.

**HISTORY**

1. New Article 8 (§§ 3370 through 3377) filed 12-29-72; effective thirtieth day thereafter (Register 72, No. 53).  
2. Renumbering of former Article 8 (Sections 3370-3377) to new Article 9 (Sections 3370-3391), and amendment of Section 3370 NOTE filed 2-22-83; effective thirtieth day thereafter (Register 83, No. 9). For history of former Article 9, see Section 3385 and Register 76, No. 52).

**§ 3371. Untrue or Misleading Statements or Advertising.**

No dealer shall publish, utter, or make or cause to be published, uttered, or made any false or misleading statement or advertisement which is known to be false or misleading, or which by the exercise of reasonable care should be known to be false or misleading. Advertisements and advertising signs shall clearly show the following:

(a) Firm Name and Address. The dealer's firm name and address as they appear on the State registration certificate as an automotive repair dealer; and

(b) Telephone Number. If a telephone number appears in an advertisement or on an advertising sign, this number shall be the same number as that listed for the dealer's firm name and address in the telephone directory, or in the telephone company records if such number is assigned to the dealer subsequent to the publication of such telephone directory.

**AUTHORITY:**

**Note:** Authority cited: Sections 9882 and 9884.19, Business and Professions Code. Reference: Sections 9884.19 and 17500, Business and Professions Code.

**HISTORY**

1. Amendment filed 6-26-74; designated effective 8-1-74 (Register 74, No. 26).  
2. New NOTE filed 2-22-83; effective thirtieth day thereafter (Register 83, No. 9).

**§ 3371.1. Presumption As Automotive Repair Dealer.**

A person shall be deemed to be an automotive repair dealer as defined by subdivision (a) of section 9880.1 of the Business and Professions Code when such person:

(a) Solicits or advertises the repair of motor vehicles by telephone directory, newspaper, periodical, airwave transmission, printed handbill, printed business card, printed poster, or painted or electric sign, and repairs motor vehicles, or

(b) maintains an establishment for the repair of motor vehicles where within or outside the establishment is a sign, poster, or other representation which might reasonably lead a member of the public to believe that such establishment performs the repair of motor vehicles, or

(c) holds a retail sellers permit when such permit has been acquired for the purpose of, or has been used for, obtaining parts for the repair of motor vehicles, or

(d) holds himself or herself out to the public as an automotive repair dealer and receives a motor vehicle from the public and transmits or renders control of the motor vehicle to another for repair.

A person will be deemed to be holding himself or herself out to the public as an automotive repair dealer within the meaning of subdivision (d) above when such person solicits such business in a manner which might reasonably lead the public to believe that such person is an automotive repair dealer, or when the person receiving the service is billed on such person's own invoice.

**AUTHORITY:**

**Note:** Authority cited: Sections 9882 and 9884.19, Business and Professions Code. Reference: Section 9884.19, Business and Professions Code.

**HISTORY**

1. New section filed 4-16-90; operative 4-16-90 (Register 90, No. 19).

**§ 3372. False or Misleading Defined.**

In determining whether any advertisement, statement, or representation is false or misleading, it shall be considered in its entirety as it would be read or heard by persons to whom it is designed to appeal. An advertisement, statement, or representation shall be considered to be false or misleading if it tends to deceive the public or impose upon credulous or ignorant persons.

**AUTHORITY:**

**Note:** Authority cited: Sections 9882 and 9884.19, Business and Professions Code. Reference: Sections 9884.7, 9884.19 and 17500, Business and Professions Code.

**HISTORY**

1. New NOTE filed 2-22-83; effective thirtieth day thereafter (Register 83, No. 9).

**§ 3372.1. Price Advertising.**

An automotive repair dealer shall not advertise automotive service at a price which is misleading. Price advertising is misleading in circumstances which include but are not limited to the following:

(a) The automotive repair dealer does not intend to sell the advertised service at the advertised price but intends to entice the consumer into a more costly transaction; or

(b) The advertisement for service has the capacity to mislead the public as to the extent that anticipated parts, labor or other services are included in the advertised price; or

(c) The advertisement for service or repair has the capacity to mislead the public as to the need for additional related parts, labor or other services; or

(d) The automotive repair dealer knows or should know that the advertised service cannot usually be performed in a good and workmanlike manner without additional parts, services or labor; provided, however, that an advertisement which clearly and conspicuously discloses that additional labor, parts or services are often needed will, to that extent, not be regarded as misleading. Any such disclosure statement shall indicate that many instances of performance of the service involve extra cost and, if the automotive dealer reasonably expects that the

extra cost will be more than 25% of the advertised costs, that the extra cost may be substantial. The type size of the disclosure statement shall be at least 1/2 the type size used in the advertised price and the statement shall either be shown near the price or shall be prominently footnoted through use of an asterisk or similar reference.

**AUTHORITY:**

**Note:** Authority cited: Sections 9882 and 9884.19, Business and Professions Code. Reference: Sections 9884.7, 9884.19 and 17500, Business and Professions Code.

**HISTORY**

1. New section filed 3-28-86; effective thirtieth day thereafter (Register 86, No. 13).

**§ 3373. False or Misleading Records.**

No automotive repair dealer or individual in charge shall, in filling out an estimate, invoice, or work order, or record required to be maintained by section 3340.15(f) of this chapter, withhold therefrom or insert therein any statement or information which will cause any such document to be false or misleading, or where the tendency or effect thereby would be to mislead or deceive customers, prospective customers, or the public.

**AUTHORITY:**

**Note:** Authority cited: Sections 9882 and 9884.19, Business and Professions Code. Reference: Sections 9884.7, 9884.19 and 17500, Business and Professions Code.

**HISTORY**

1. New Note filed 2-22-83; effective thirtieth day thereafter (Register 83, No. 9).

2. Amendment filed 8-18-92; operative 9-17-92 (Register 92, No. 37).

**§ 3374. New, Rebuilt, Reconditioned, or Used Parts and Components.**

No dealer shall advertise, represent, or in any manner imply that a used, rebuilt or reconditioned part or component is new unless such part and all of the parts of any component are in fact new.

**AUTHORITY:**

**Note:** Authority cited: Sections 9882 and 9884.19, Business and Professions Code. Reference: Sections 9884.7, 9884.8, 9884.19 and 17500, Business and Professions Code.

**HISTORY**

1. Amendment filed 2-22-83; effective thirtieth day thereafter (Register 83, No. 9).

**§ 3374.1. Manufacture, Sale, or Installation of Defective Vehicle Parts.**

**AUTHORITY:**

**Note:** Authority cited: Section 9882, Business and Professions Code. Reference: Sections 12000-12002, Vehicle Code.

**HISTORY**

1. New section filed 6-26-74; designated effective 8-1-74 (Register 74, No. 26).

2. Amendment filed 12-23-76; effective thirtieth day thereafter (Register 76, No. 52).

3. Renumbering and amendment of Section 3374.1 to Section 3395.3 filed 2-22-83; effective thirtieth day thereafter (Register 83, No. 9).

**§ 3375. Guarantees and Warranties.**

For the purpose of this Act and of these regulations the term "guarantee" and "warranty" have like meanings. No advertisement shall contain any false or misleading representation concerning the nature, extent,

duration, terms or cost of a guarantee of a motor vehicle part or component or repair service subject to the provisions of the Act.

**AUTHORITY:**

**Note:** Authority cited: Sections 9882 and 9884.19, Business and Professions Code. Reference: Sections 9884.19 and 17500, Business and Professions Code.

**HISTORY**

1. New NOTE filed 2-22-83; effective thirtieth day thereafter (Register 83, No. 9).

**§ 3376. Disclosure of Guarantee.**

All guarantees shall be in writing and a legible copy thereof shall be delivered to the customer with the invoice itemizing the parts, components, and labor represented to be covered by such guarantee. A guarantee shall be deemed false and misleading unless it conspicuously and clearly discloses in writing the following:

(a) The nature and extent of the guarantee including a description of all parts, characteristics or properties covered by or excluded from the guarantee, the duration of the guarantee and what must be done by a claimant before the guarantor will fulfill his obligation (such as returning the product and paying service or labor charges).

(b) The manner in which the guarantor will perform. The guarantor shall state all conditions and limitations and exactly what the guarantor will do under the guarantee, such as repair, replacement or refund. If the guarantor or recipient of the guarantee has an option as to what may satisfy the guarantee, this must be clearly stated.

(c) The guarantor's identity and address shall be clearly revealed in any documents evidencing the guarantee.

**AUTHORITY:**

**Note:** Authority cited: Sections 9882 and 9884.19, Business and Professions Code. Reference: Sections 9884.19 and 17500, Business and Professions Code.

**HISTORY**

1. New NOTE filed 2-22-83; effective thirtieth day thereafter (Register 83, No. 9).

**§ 3377. Pro-Rata Guarantee.**

Any guarantee or any advertisement of a guarantee which provides for adjustment on a pro-rata basis shall be deemed false and misleading unless the guarantee and/or the advertisement conspicuously and clearly discloses this fact and the basis on which the guarantee will be pro-rated, e.g., the time or mileage the part, component, or item repaired has been used and in what manner the guarantor will perform. If adjustments are based on a price other than that paid by the customer, clear disclosure must be made of the amount. However, a fictitious price must not be used even where the sum is adequately disclosed.

**AUTHORITY:**

**Note:** Authority cited: Sections 9882 and 9884.19, Business and Professions Code. Reference: Sections 9884.19 and 17500, Business and Professions Code.

**HISTORY**

1. New NOTE filed 2-22-83; effective thirtieth day thereafter (Register 83, No. 9).

**§ 3385. Display.**

**AUTHORITY:**

**Note:** Authority cited: Section 9882, Business and Professions Code. Reference: Section 9884.17, Business and Professions Code.

**HISTORY**

1. New Article 9 (Sections 3385 and 3386) filed 12-29-72; effective thirtieth day thereafter (Register 72, No. 53).  
2. Amendment filed 12-23-76; effective thirtieth day thereafter (Register 76, No. 52).  
3. Redesignation of former Article 9 (Sections 3385-3386) to new Article 9 (Sections 3370-3391), and renumbering and amendment of Section 3385 to Section 3351.3 filed 2-22-83; effective thirtieth day thereafter (Register 83, No. 9)

**§ 3386. Specifications for Automotive Repair Dealer's Sign.**

**HISTORY**

1. Editorial correction (Register 75, No. 4).  
2. Renumbering and amendment of Section 3386 to Section 3351.4 filed 2-22-83; effective thirtieth day thereafter (Register 83, No. 9).

**§ 3390. Fees.**

**AUTHORITY:**

**Note:** Authority cited: Section 9882, Business and Professions Code. Reference: Section 9886.3, Business and Professions Code.

**HISTORY**

1. New Article 10 (Section 3390) filed 12-29-72; effective thirtieth day thereafter (Register 72, No. 53).  
2. Amendment filed 6-26-74; designated effective 8-1-74 (Register 74, No. 26).  
3. Amendment of subsections (a)-(c) filed 11-27-81; designated effective 1-1-82 (Register 81, No. 48).  
4. Redesignation of former Article 10 (Sections 3390-3391) to new Article 10 (Sections 3395-3395.3), and renumbering and amendment of Section 3390 to Section 3351.1 filed 2-22-83; effective thirtieth day thereafter (Register 83, No. 9).

**§ 3391. Renewal of Automotive Repair Dealer Registration.**

**AUTHORITY:**

**Note:** Authority cited: Sections 152.5, 152.6, 9882, Business and Professions Code. Reference: Sections 152.5, 152.6, Business and Professions Code.

**HISTORY**

1. New section filed 4-28-76; effective thirtieth day thereafter (Register 76, No. 18).  
2. Amendment filed 6-9-78; effective thirtieth day thereafter (Register 78, No. 23).  
3. Renumbering and amendment of Section 3391 to Section 3351.2 filed 2-22-83; effective thirtieth day thereafter (Register 83, No. 9).

**ARTICLE 10.**

**Station Performance Programs**

§ 3392.1. Gold Shield Program (GSP).

§ 3392.2. Responsibilities of Smog Check Stations Certified as Gold Shield.

§ 3392.2.1. Required Services of STAR Stations

§ 3392.3. Eligibility for Gold Shield Certification; Quality Assurance.

§ 3392.3.1. Eligibility/Performance Standards for STAR Certification

§ 3392.4. STAR Program Evaluations.

§ 3392.5. Causes for Invalidation of Gold Shield Station Certification.

§ 3392.5.1. Causes for Invalidation of STAR Station Certification

§ 3392.6. Gold Shield Program Hearing and Determination.

§ 3392.6.1. STAR Program Hearing and Determination

**§ 3392.1. Gold Shield Program (GSP).**

This section shall remain in effect through December 31, 2012. The Gold Shield Program is a voluntary pro-

gram that permits any licensed Smog Check test-and-repair station, which meets or exceeds the standards established pursuant to this article to obtain a certification that may be publicly displayed and otherwise advertised.

(a) The purposes of the Gold Shield program are to:

(1) Reduce the complexity of the Smog Check Program by allowing Smog Check stations certified as Gold Shield stations to offer consumers a wider array of inspection and repair services.

(2) Encourage consumer confidence in the required emissions inspections and repairs by the establishment of inspection and repair standards that stations must meet or exceed to receive and retain certification from the Bureau.

(3) Improve the identification and repair of high-emitting vehicles to enhance the effectiveness of the Smog Check Program.

(4) Contribute to the emissions reductions objectives required by the State Implementation Plan and federal standards.

**AUTHORITY:**

**Note:** Authority cited: Sections 44001.5, 44002 and 44014.2, Health and Safety Code. Reference: Sections 44002 and 44014.2, Health and Safety Code.

**HISTORY**

1. Renumbering of former article 10 to new article 11 (sections 3395-3395.3), and new article 10 (sections 3392.1-3392.6) and section filed 4-23-97 as an emergency; operative 4-23-97 (Register 97, No. 17). A Certificate of Compliance must be transmitted to OAL by 8-21-97 or emergency language will be repealed by operation of law on the following day.

2. Certificate of Compliance as to 4-23-97 order, including amendment of first paragraph and Note, transmitted to OAL 8-19-97 and filed 9-30-97 (Register 97, No. 40).

3. Amendment of section heading, repealer and new section and amendment of Note filed 4-28-2003; operative 5-28-2003 (Register 2003, No. 18).

4. Amendment of introductory paragraph filed 11-1-2011; operative 11-1-2011 pursuant to Government Code section 11343.4 (Register 2011, No. 44).

**§ 3392.2. Responsibilities of Smog Check Stations Certified as Gold Shield.**

This section shall remain in effect through December 31, 2012.

(a) Smog Check test-and-repair stations certified as Gold Shield stations shall provide the following services to the public:

(1) State subsidized emissions-related repairs, under the terms and conditions of a contract executed pursuant to Section 3394.2, as a component of the Bureau's Consumer Assistance Program established pursuant to Article 11 of this Division. This paragraph shall not apply to those stations located in change of ownership program areas.

(2) The certification of vehicles previously identified as gross polluters.

(3) For Gold Shield stations with a complete BAR-97 Emissions Inspection System capable of performing enhanced area loaded-mode inspections pursuant to paragraph (1) of subdivision (a) of Section 44003 of the Health and Safety Code, irrespective of their program area location, the initial testing and certification of vehicles directed to Test-Only stations pursuant to Sections 44010.5 or 44014.7 of the Health and Safety Code.

(4) For Gold Shield stations with a complete BAR-97 Emissions Inspection System capable of performing enhanced area loaded-mode inspections pursuant to paragraph (1) of subdivision (a) of Section 44003 of the Health and Safety Code, irrespective of their program area location, the after-repairs certification of failed vehicles that were directed to and initially tested at Test-Only stations pursuant to Sections 44010.5 or 44014.7 of the Health and Safety Code provided that the vehicles are repaired at the Gold Shield station.

(5) For Gold Shield stations located in basic or change of ownership program areas that do not perform enhanced area loaded-mode inspections pursuant to paragraph (1) of subdivision (a) of Section 44003 of the Health and Safety Code, the certification of vehicles registered in enhanced areas if the vehicles were purchased by a licensed Department of Motor Vehicles Motor Vehicle Dealer, as defined in Section 285 of the Vehicle Code, with the intent of offering the vehicles for sale upon the dealer's premises that are located in basic or change of ownership areas. Gold Shield stations authorized pursuant to this paragraph shall not issue a certificate of compliance to a vehicle registered in an enhanced area that is required to have an enhanced area test if the vehicle is owned by an entity other than a Motor Vehicle Dealer licensed by the Department of Motor Vehicles.

(b) All emissions-related repairs at a Gold Shield station shall be performed in a good and workmanlike manner and in accordance with the procedures specified by the vehicle manufacturer or by repair standards generally accepted by the industry.

(c) A Gold Shield station shall display an exterior sign that meets the following specifications:

(1) The dimensions of the sign shall be 24 inches wide and 30 inches high.

(2) The sign shall be made of 0.040-inch aluminum, steel, or plastic.

(3) The Bureau shall supply a camera-ready design and content of the sign.

(d) A Gold Shield station may advertise those services authorized by subsection (a), other than by displaying the sign specified in subsection (c).

(e) A Gold Shield station shall allow bureau personnel reasonable access to the station for the on-site inspection of vehicles where repairs are still in progress or have been completed and the vehicles remain on the premises. The inspections shall be for the purpose of evaluating the appropriateness and effectiveness of the repairs performed by the station.

**AUTHORITY:**

**Note:** Authority cited: Sections 44001.5, 44002, 44010.5, 44014.2 and 44095, Health and Safety Code. Reference: Sections 44010.5, 44014, 44014.2 and 44092, Health and Safety Code.

**HISTORY**

1. New section filed 4-23-97 as an emergency; operative 4-23-97 (Register 97, No. 17). A Certificate of Compliance must be transmitted to OAL by 8-21-97 or emergency language will be repealed by operation of law on the following day.

2. Certificate of Compliance as to 4-23-97 order, including amendment of first paragraph and subsections (d) and (e), new subsections (f) and (g) and amendment of Note, transmitted to OAL 8-19-97 and filed 9-30-97 (Register 97, No. 40).

3. Amendment of section heading, repealer and new section and amendment of Note filed 4-28-2003; operative 5-28-2003 (Register 2003, No. 18).

4. New subsection (a)(3), subsection renumbering, amendment of newly designated subsections (a)(4)-(5) and amendment of Note filed 8-1-2007; operative 8-1-2007 pursuant to Government Code section 11343.4 (Register 2007, No. 31).

5. Amendment of introductory paragraph filed 11-1-2011; operative 11-1-2011 pursuant to Government Code section 11343.4 (Register 2011, No. 44).

#### § 3392.2.1. Required Services of STAR Stations.

This section shall become effective January 1, 2013.

(a) Both STAR certified test-only and test-and-repair stations shall provide the following services to the public:

(1) The certification of vehicles previously identified as gross polluters.

(2) For STAR stations with a complete BAR-certified Emissions Inspection System capable of performing enhanced area ASM inspections on all vehicles subject to Smog Check pursuant to Sections 44003 and 44003.5 of the Health and Safety Code, irrespective of their program area location, perform the testing and certification of vehicles requiring inspection pursuant to Sections 44010.5 or 44014.7 of the Health and Safety Code.

(3) For STAR stations located in basic or change of ownership program areas that do not perform ASM inspections pursuant to Sections 44003 and 44003.5 of the Health and Safety Code, perform the testing and certification of vehicles registered in enhanced areas only if the vehicles were purchased by a licensed Department of Motor Vehicles motor vehicle dealer, as defined in Section 285 of the Vehicle Code, with the intent of offering the vehicles for sale upon the dealer's premises located in a basic or change of ownership area. STAR stations authorized pursuant to this paragraph may not issue a certificate of compliance to a vehicle that is owned by an entity other than a motor vehicle dealer licensed by the Department of Motor Vehicles.

(b) STAR certified test-and-repair stations shall do the following:

(1) Under the terms and conditions of an agreement executed pursuant to Section 3394.2, offer state subsidized emissions-related repairs as a component of the Consumer Assistance Program established pursuant to Article 11 of this chapter. This paragraph shall apply to those STAR certified stations located in basic and enhanced areas.

(2) Perform all emissions-related repairs in a good and workmanlike manner and in accordance with the procedures specified by the vehicle manufacturer or by repair standards generally accepted by the industry.

(3) Allow bureau personnel reasonable access to the station for the on-site inspection of vehicles while repairs are in progress, or for inspection of repaired vehicles still remaining on the premises. These inspections shall be for the purpose of evaluating the appropriateness and effectiveness of the repairs performed by the station.

#### AUTHORITY:

**Note:** Authority cited: Sections 44001.5, 44002, 44010.5, 44014.2 and 44095, Health and Safety Code; and Section 9882, Business and Professions Code. Reference: Sections 44010.5, 44014, 44014.2 and 44092, Health and Safety Code.

#### HISTORY

1. New section filed 11-1-2011; operative 11-1-2011 pursuant to Government Code section 11343.4 (Register 2011, No. 44).

#### § 3392.3. Eligibility for Gold Shield Certification; Quality Assurance.

This section shall remain in effect through December 31, 2012.

(a) A licensed Smog Check Test-and-Repair station seeking Gold Shield certification shall complete and file a Gold Shield Station Application form (GSR-1 04/25/2003), which is hereby incorporated by reference, and shall, as of the date the application is received by the bureau, meet all of the following eligibility requirements:

(1) The station's Comparative Failure Rate (CFR) over the preceding calendar quarter must meet or exceed the industry-wide failure rate for Test-Only stations, by smog check program area, as calculated quarterly by the bureau.

(2) The station must have conducted a minimum of 10 successful emission repairs in the preceding calendar quarter. For the purposes of this section, a "successful emission repair" means:

(A) The vehicle must have failed the emissions portion of a Smog Check in official test mode or pre-test mode at any Smog Check station prior to the repair; and

(B) The Smog Check station must have repaired the vehicle and entered repair data into the Vehicle Information Database; and

(C) The vehicle must have been issued a Certificate of Compliance at any Smog Check station within ten (10) days following the repairs made by the applicant Smog Check station.

(3) The station's repair performance, in the preceding calendar quarter, must rate within the top 75% of test-and-repair stations in the same smog check program area. A station's repair performance is computed by comparing the final emission readings of each successful emission repair to the average passing emission readings for the same model-year and emission standards category of the vehicle repaired.

(4) The station must not have been issued any citations pursuant to Section 44050(a) of the Health and Safety Code within the preceding one-year period nor employ any technicians who have been issued any citations pursuant to Section 44050(b) of the Health and Safety Code within the preceding one-year period.

(5) Neither the current nor any previous registration or license of the station owner, manager and licensed Smog Check technicians employed by the station, has been issued an order of suspension, a probationary order, or any other disciplinary order within the preceding three-year period. No station owner, officer, manager, licensed Smog Check technician or other employee of the station may currently be subject to suspension, probation or other disciplinary order.

(6) The station owner, manager and licensed Smog Check technicians or other employees of the station, must not have been convicted of a crime within the preceding three-year period that is substantially related to the duties of an Automotive Repair Dealer, a licensed Smog Check station, or a licensed Smog Check technician. The station owner, manager and licensed Smog Check technicians or other employees of the station, must not have been found liable in a civil proceeding, excluding small claims matters, within the preceding three-year period,

for acts or omissions that are substantially related to the duties of an Automotive Repair Dealer, a licensed Smog Check station, or a licensed Smog Check technician. The station owner, manager and licensed Smog Check technicians or other employees of the station must not be serving a probationary period as a result of any such criminal or civil proceeding.

(7) The station must not have engaged in any conduct that would be cause for discipline of the station's Automotive Repair Dealer registration or Smog Check station license.

(8) The station must pass a Quality Assurance inspection administered by bureau personnel as part of the certification process. A Quality Assurance inspection consists of any or all of the following:

(A) A verification of compliance with all licensure and license posting requirements.

(B) A verification of compliance with all signage requirements.

(C) A verification of compliance with all estimate, repair order, invoice and record-keeping requirements.

(D) A verification of possession of all required manuals and publications.

(E) A verification of possession of all required tools and equipment and a verification of their proper working order.

(F) Evaluations of licensed smog check technicians' ability to perform complete smog check inspections, and diagnoses and repairs of failed vehicles.

(b) Smog Check stations located in change of ownership program areas shall only have to meet standards (a) (4)-(a)(7), inclusive, to obtain Gold Shield certification.

(c) The bureau may conduct periodic quality assurance inspections of the station. If a Gold Shield station's performance does not comply with the criteria established pursuant to this section, written notice of the deficiency shall be provided to the station by the bureau, and the station shall have sixty (60) days to correct the deficiency. The bureau may conduct a follow-up quality assurance inspection to ensure the deficiency has been corrected.

(d) The bureau, on a quarterly basis, shall evaluate a Gold Shield station's inspection and repair performance and compliance with the criteria established pursuant to this section. A Gold Shield station that fails to meet the certification criteria specified in paragraphs (1), (2) or (3) of Subsection (a) of this section, will be notified in writing of the nature of the deficiency. The Gold Shield station may be given one additional quarter to meet those standards.

(e) A station may, upon ten (10) days written notice to the Bureau, withdraw from the Gold Shield Program.

**AUTHORITY:**

**Note:** Authority cited: Sections 44001.5 and 44014.2, Health and Safety Code. Reference: Section 44014.2, Health and Safety Code.

**HISTORY**

1. New section filed 4-23-97 as an emergency; operative 4-23-97 (Register 97, No. 17). A Certificate of Compliance must be transmitted to OAL by 8-21-97 or emergency language will be repealed by operation of law on the following day.

2. Certificate of Compliance as to 4-23-97 order, including amendment of subsections (a), (b)(1), (b)(3) and (b)(5)-(6), transmitted to OAL 8-19-97 and filed 9-30-97 (Register 97, No. 40).

3. Amendment of section heading, repealer and new section and amendment of Note filed 4-28-2003; operative 5-28-2003 (Register 2003, No. 18).

4. New introductory paragraph filed 11-1-2011; operative 11-1-2011 pursuant to Government Code section 11343.4 (Register 2011, No. 44).

**§ 3392.3.1. Eligibility/Performance Standards for STAR Certification.**

(a) A licensed Smog Check test-and-repair or test-only station seeking STAR certification shall submit to the bureau a completed STAR Station Certification Application form (STAR-1 07/1/2012), which is hereby incorporated by reference, and shall, as of the date the application is received by the bureau, meet all of the following eligibility/performance standard requirements. Applications for the STAR program that begins January 1, 2013 may be submitted beginning July 1, 2012.

(1) The station's Similar Vehicle Failure Rate (SVFR) in the most recently completed calendar quarter shall be greater than or equal to 75% of the industry-wide failure rate for similar vehicles, as defined in Section 3340.1.

(2) The station shall have no more than 2% of vehicles tested with Gear Shift Incidents in the most recently completed calendar quarter, as defined in Section 3340.1.

(3) The station shall have an Excessive Test Deviation Rate of no more than one in the most recently completed calendar quarter, as defined in Section 3340.1.

(4) The station shall employ, for the purpose of performing smog check inspections and/or smog check repairs, licensed technicians whose FPR scores are greater than or equal to 0.4 in the most recently completed FPR reporting period.

(A) The station is deemed to employ, for the purpose of performing smog check inspections and/or smog check repairs, a licensed technician if that technician is listed in the station's Technician Information Table(s), as defined in Section 3340.1.

(B) If a station employs, for the purpose of performing smog check inspections and/or smog check repairs, a licensed technician who has not received an FPR score in the most recently completed reporting period, the station may be eligible for STAR certification if; the station's FPR score in the most recently completed reporting period is greater than or equal to 0.4 or the station did not receive an FPR score in the most recently completed reporting period and all other eligibility requirements have been met.

(5) A station cannot have received a citation which is final and non-appealable, nor can a station employ a licensed Smog Check technician who has received a citation which is final and non-appealable, within the preceding one-year period from the effective date of the citation for violation of any of the following sections: 44012, 44015 (a) and (b), 44015.5, 44016, and 44032 of the Health and Safety Code; and 3340.15 (a), 3340.16 (a) and (b), 3340.16.5 (a) and (b), 3340.17, 3340.30 (a), 3340.35, 3340.41 (b), 3340.41 (c), 3340.42, 3340.42.2, and 3340.45 of Division 33, Title 16, California Code of Regulations.

(6) The current or any previous registration or license of the station owner, manager, or licensed Smog Check technicians employed by the station cannot be issued an order of suspension or a probationary order within the preceding three-year period from the effective



date of the action. No station owner, officer, manager, licensed Smog Check technician or other employee of the station may currently be subject to an order of suspension or a probationary order.

(7) The station owner, manager, licensed Smog Check technicians, or any other employee of the station may not have been convicted of a crime within the preceding three-year period that is substantially related to the duties of an Automotive Repair Dealer, a licensed Smog Check station, or a licensed Smog Check technician. The station owner, manager, licensed Smog Check technicians, or any other employees of the station may not have been found liable in a civil proceeding, excluding small claims matters, within the preceding three-year period, for acts or omissions that are substantially related to the duties of an Automotive Repair Dealer, a licensed Smog Check station, or a licensed Smog Check technician. The station owner, manager, licensed Smog Check technicians, or any other employees of the station may not be serving a probationary period as a result of a criminal or civil proceeding substantially related to the duties of an Automotive Repair Dealer, a licensed Smog Check station, or a licensed Smog Check technician.

(8) Compliance with all licensure and license posting requirements.

(9) Compliance with all estimate, repair order, invoice and record-keeping requirements.

(10) Physical possession of, and/or electronic access to, all required manuals and publications.

(11) Possession of all required tools and equipment and a verification of their proper working order.

(12) A STAR certified station shall display an exterior sign, directly below the sign described in section 3340.22, which meets the following specifications:

(A) The dimensions of the sign shall be 24 inches wide and 5 1/4 inches high.

(B) The sign shall be made of 0.040-inch aluminum, steel, or plastic.

(C) The bureau shall supply a camera-ready design and content of the sign.

(13) The station may not have had its STAR certification invalidated within the last six months.

(b) A licensed Smog Check test-only or test-and-repair station seeking STAR certification shall be informed, in writing or by electronic mail, of the bureau's decision that the station meets the eligibility requirements for certification or the application is deficient.

**AUTHORITY:**

**Note:** Authority cited: Sections 44001.5 and 44014.2, Health and Safety Code; and Section 9882, Business and Professions Code. Reference: Section 44014.2, Health and Safety Code.

**HISTORY**

1. New section filed 11-1-2011; operative 11-1-2011 pursuant to Government Code section 11343.4 (Register 2011, No. 44).

**§ 3392.4. STAR Program Evaluations.**

This section shall become effective January 1, 2013.

(a) All STAR certified stations shall continue to meet the criteria established pursuant to Section 3392.3.1 (a).

(b) The bureau may conduct a physical inspection of the STAR station to ensure compliance with the requirements established in Section 3392.3.1 (a)(8)-(13).

(c) The STAR program evaluation may be viewed on the bureau's online website.

**AUTHORITY:**

**Note:** Authority cited: Section 44001.5, Health and Safety Code. Reference: Section 44014.2, Health and Safety Code.

**HISTORY**

1. New section filed 11-1-2011; operative 11-1-2011 pursuant to Government Code section 11343.4 (Register 2011, No. 44). For prior history, see Register 2003, No. 18.

**§ 3392.5. Causes for Invalidation of Gold Shield Station Certification.**

(a) Effective through December 31, 2012, it shall be cause for the Bureau to invalidate the certification of a Gold Shield station, temporarily or permanently, if any of the following occur:

(1) The Gold Shield station, manager or Smog Check technicians employed by the station, engage in any conduct which violates any provision of this article or which would be cause for discipline of, or which would be cause for issuance of a citation to the station's Automotive Repair Dealer registration or Smog Check station license, or the license of a technician employed by the station.

(2) The Gold Shield station's Automotive Repair Dealer registration or Smog Check station license expires or otherwise becomes delinquent.

(3) The bureau disciplines the Gold Shield station's Automotive Repair Dealer registration or Smog Check station license in any form or manner.

(4) The Gold Shield station fails or is unable to provide the services specified in section 3392.2(a).

(5) The Gold Shield station, if located in other than an enhanced area, issues a certificate of compliance to a vehicle registered in an enhanced area that is required to have an enhanced area test if the vehicle is owned by an entity other than a motor vehicle dealer licensed by the Department of Motor Vehicles, unless the station performed an enhanced area test as prompted by the Emissions Inspection System.

(6) The Gold Shield station fails to comply with the certification criteria specified in paragraph (a)(1), (2) or (3) of Section 3392.3 for two consecutive calendar quarters.

(7) The Gold Shield station fails to correct a deficiency identified in a quality assurance inspection within the specified time period.

(b) Effective January 1, 2013, all existing Gold Shield certifications will expire. All stations choosing to participate in the STAR program that takes effect January 1, 2013, may apply for certification pursuant to Section 3392.3.1.

**AUTHORITY:**

**Note:** Authority cited: Sections 44001.5 and 44014.2, Health and Safety Code. Reference: Sections 44014.2 and 44037.1, Health and Safety Code; and Sections 480 and 490, Business and Professions Code.

**HISTORY**

1. New section filed 4-23-97 as an emergency; operative 4-23-97 (Register 97, No. 17). A Certificate of Compliance must be transmitted to OAL by 8-21-97 or emergency language will be repealed by operation of law on the following day.

2. Certificate of Compliance as to 4-23-97 order, including amendment of subsections (d), new subsections (e) and (f) and amendment of Note, transmitted to OAL 8-19-97 and filed 9-30-97 (Register 97, No. 40).

3. Amendment of section heading, repealer and new section and amendment of Note filed 4-28-2003; operative 5-28-2003 (Register 2003, No. 18).

4. Amendment of subsection (a) and new subsection (b) filed 11-1-2011; operative 11-1-2011 pursuant to Government Code section 11343.4 (Register 2011, No. 44).

**§ 3392.5.1. Causes for Invalidation of STAR Station Certification.**

This section shall become effective January 1, 2013.

(a) It shall be cause for the bureau to invalidate the certification of a STAR station if any of the following occur:

(1) The STAR station, manager, or any licensed technician employed by the station receives an order of suspension, a probationary order, or a citation that is final and non-appealable for violation of any of the following sections: 44012, 44015 (a) and (b), 44015.5, 44016, and 44032 of the Health and Safety Code; and 3340.15 (a), 3340.16 (a) and (b), 3340.16.5 (a) and (b), 3340.17, 3340.30 (a), 3340.35, 3340.41 (b), 3340.41 (c), 3340.42, 3340.42.2, and 3340.45 of Division 33, Title 16, California Code of Regulations.

(2) The STAR station's Automotive Repair Dealer registration or Smog Check station license expires or otherwise becomes delinquent.

(3)(A) The station owner, manager, licensed Smog Check technicians, or any other employee of the station is convicted of a crime substantially related to the duties of an Automotive Repair Dealer, a licensed Smog Check station, or a licensed Smog Check technician.

(B) The station owner, manager, licensed Smog Check technician, or any other employee of the station is found liable in a civil proceeding, excluding small claims matters, for acts or omissions that are substantially related to the duties of an Automotive Repair Dealer, a licensed Smog Check station, or a licensed Smog Check technician.

(C) The station owner, manager, licensed Smog Check technician, or any other employee of the station begins serving a probationary period as a result of a criminal or civil proceeding substantially related to the duties of an Automotive Repair Dealer, a licensed Smog Check station, or a licensed Smog Check technician.

(4) The STAR station fails to comply with any of the certification criteria specified in Section 3392.3.1 (a)(1)-(3) for two consecutive calendar quarters.

(5) The STAR station continues to employ, for the purpose of performing smog check inspections and/or smog check repairs, a licensed technician whose FPR score in the most recently completed FPR reporting period is less than 0.1. A smog check station may choose to have the bureau automatically remove technicians not meeting this requirement from each of the station's EIS Technician Information Tables.

(6) The STAR station continues to employ, for the purpose of performing smog check inspections and/or smog check repairs, a licensed technician who did not receive an FPR score in the most recently completed reporting period and the station's FPR score in the most recently completed FPR reporting period is less than 0.1.

(7) The STAR station hires, for the purpose of performing smog check inspections and/or smog check repairs, a licensed technician whose FPR score in the most recently completed FPR reporting period is less than 0.4.

(8) The STAR station has an FPR score of less than 0.4 and hires, for the purpose of performing smog check inspections and/or smog check repairs, a licensed technician who did not receive an FPR score in the most recently completed FPR reporting period.

(9) The STAR station fails or is unable to provide applicable services specified in Section 3392.2.1.

(10) The STAR station, if located in a basic or change of ownership area, fails to perform an ASM test and issues a certificate of compliance to a vehicle registered in an enhanced area that is owned by an entity other than a motor vehicle dealer licensed by the Department of Motor Vehicles and located in an enhanced area.

(b) The STAR station may withdraw from the STAR program by providing written notice to the bureau.

(c) If a station's STAR certification is invalidated or the station withdraws from the STAR program, the station may not perform the services pursuant to Section 3392.2.1 (a)(1)-(3) and (b)(1).

**AUTHORITY:**

**Note:** Authority cited: Sections 44001.5 and 44014.2, Health and Safety Code; and Section 9882, Business and Professions Code. Reference: Sections 44014.2 and 44037.1, Health and Safety Code; and Sections 480 and 490, Business and Professions Code.

**HISTORY**

1. New section filed 11-1-2011; operative 11-1-2011 pursuant to Government Code section 11343.4 (Register 2011, No. 44).

**§ 3392.6. Gold Shield Program Hearing and Determination.**

Effective through December 31, 2012, if the bureau denies an application for Gold Shield certification or if the bureau invalidates, temporarily or permanently, an existing Gold Shield station's certification, the bureau shall file and serve a written notice of denial or invalidation. The written notice shall contain a summary of the facts and allegations which form the cause or causes for denial or invalidation.

(a) Service of the written notice may be effected in any manner authorized by Business and Professions Code Section 124.

(b) If a written request for a hearing is delivered 15 days from the date of service, a hearing shall be held as provided for in (c) below.

(c) The bureau shall schedule a hearing within 60 days of the date the bureau receives a timely request for a hearing. The bureau shall notify the applicant or certified Gold Shield station or representative of the time and place of the hearing. The hearing shall be limited in scope to the time period, and facts and allegation specified in the written notice prepared by the bureau.

(d) The applicant or Gold Shield station shall be notified of the determination by the chief, or the chief's designee, who shall issue a decision and notify the applicant or Gold Shield station within 15 days of the close of the hearing.

(e) The bureau may order that a certification be temporarily invalidated pending any hearing and pending any post-hearing decision of the chief.

**AUTHORITY:**

**Note:** Authority cited: Sections 44001.5 and 44014.2, Health and Safety Code. Reference: Section 44014.2, Health and Safety Code; and Section 124, Business and Professions Code.

**HISTORY**

1. New section, including form GSR-1, filed 4-23-97 as an emergency; operative 4-23-97 (Register 97, No. 17). A Certificate of Compliance must be transmitted to OAL by 8-21-97 or emergency language will be repealed by operation of law on the following day.
2. Certificate of Compliance as to 4-23-97 order, including amendment of form GSR-1 and removal of form from printed version of California Code of Regulations, transmitted to OAL 8-19-97 and filed 9-30-97 (Register 97, No. 40).
3. Amendment of section heading, section and Note filed 4-28-2003; operative 5-28-2003 (Register 2003, No. 18).
4. Amendment of introductory paragraph filed 11-1-2011; operative 11-1-2011 pursuant to Government Code section 11343.4 (Register 2011, No. 44).

**§ 3392.6.1. STAR Program Hearing and Determination.**

Effective January 1, 2013, if the bureau finds cause to invalidate the certification of an existing STAR station, the bureau shall file and serve a notice in writing or by electronic mail to the station. The notice shall contain a summary of the facts and allegations which form the cause or causes for invalidation.

(a) Service of the notice may be given in any manner authorized by Business and Professions Code Section 124.

(b) If a written or electronic request for a hearing is received within five (5) days from the date of service, a hearing shall be held as provided for in (c) below.

(c) The bureau shall hold a hearing within ten (10) days of the date on which the bureau received a timely request for a hearing. The bureau shall notify the STAR certified station or representative of the time and place of the hearing. The hearing shall be limited in scope to the time period, facts, and allegations specified in the notice prepared by the bureau.

(d) The STAR certified station shall be notified of the determination by the chief, or the chief's designee, who shall issue a decision and notify the applicant or STAR station within 10 days of the close of the hearing.

(e) The STAR station may request an administrative hearing to contest the decision of the chief within 30 days of the date of the determination by the chief, or the chief's designee.

**AUTHORITY:**

**Note:** Authority cited: Sections 44001.5 and 44014.2, Health and Safety Code. Reference: Section 44014.2, Health and Safety Code; and Section 124, Business and Professions Code.

**HISTORY**

1. New section filed 11-1-2011; operative 11-1-2011 pursuant to Government Code section 11343.4 (Register 2011, No. 44).

**ARTICLE 11.****Consumer Assistance Program and Enhanced Fleet Modernization Program**

- § 3394.1. Purpose and Components of the Consumer Assistance Program.
- § 3394.2. Consumer Assistance Program Administration.
- § 3394.3. State Assistance Limits.
- § 3394.4. Eligibility Requirements.
- § 3394.5. Ineligible Vehicles.
- § 3394.6. Application and Documentation Requirements for the Consumer Assistance Program.
- § 3394.7. Application and Documentation Requirements for the Enhanced Fleet Modernization Program.

**§ 3394.1. Purpose and Components of the Consumer Assistance Program.**

The purpose of the Consumer Assistance Program (CAP) is to improve California air quality. Vehicle owners, who meet eligibility requirements, are offered the following:

(a) Payment for voluntarily retiring from operation a motor vehicle.

(b) Financial assistance to make emissions-related repairs to a vehicle that fails a smog check inspection.

**AUTHORITY:**

**Note:** Authority cited: Sections 44000, 44001.3, 44001.5, 44002 and 44091, Health and Safety Code. Reference: Sections 44011, 44062.1, 44090, 44091, 44092, 44093, 44094, 44095 and 44125, Health and Safety Code.

**HISTORY**

1. Renumbering of former article 11 to new article 12 (sections 3395-3395.4) and new article 11 (sections 3394.1-3394.5) and new section filed 12-3-98 as an emergency; operative 12-3-98 (Register 98, No. 49). A Certificate of Compliance must be transmitted to OAL by 4-2-99 or emergency language will be repealed by operation of law on the following day.
2. Renumbering of former article 11 to new article 12 (sections 3395-3395.4) and new article 11 (sections 3394.1-3394.5) and new section refiled 3-30-99 as an emergency; operative 4-2-99 (Register 99, No. 14). A Certificate of Compliance must be transmitted to OAL by 11-30-99 or emergency language will be repealed by operation of law on the following day.
3. Renumbering of former article 11 to new article 12 (sections 3395-3395.4) and new article 11 (sections 3394.1-3394.5) and section refiled 7-26-99 as an emergency; operative 8-2-99 (Register 99, No. 31). A Certificate of Compliance must be transmitted to OAL by 11-30-99 or emergency language will be repealed by operation of law on the following day.
4. Certificate of Compliance as to 7-26-99 order, including amendment of section heading, section and Note, transmitted to OAL 11-18-99 and filed 1-3-2000 (Register 2000, No. 1).
5. Amendment of article heading, section heading, section and Note filed 6-26-2000 as an emergency; operative 7-1-2000 (Register 2000, No. 26). A Certificate of Compliance must be transmitted to OAL by 10-30-2000 or emergency language will be repealed by operation of law on the following day.
6. Amendment of article heading, section heading, section and Note refiled 10-30-2000 as an emergency; operative 10-30-2000 (Register 2000, No. 44). A Certificate of Compliance must be transmitted to OAL by 2-27-2001 or emergency language will be repealed by operation of law on the following day.
7. Certificate of Compliance as to 10-30-2000 order, including further amendment of section heading and section, transmitted to OAL 2-9-2001 and filed 3-27-2001 (Register 2001, No. 13).
8. Amendment of article heading, section and Note filed 7-30-2010 as an emergency; effective 7-30-2010. Emergency regulation shall become operative on the effective date of the Air Resources Board's AB 118 Enhanced Fleet Modernization Program regulations, 13 CCR division 3, chapter 13, sections 2620-2630. A Certificate of Compliance must be transmitted to OAL by 1-26-2011 or emergency language will be repealed by operation of law on the following day (Register 2010, No. 31).
9. Certificate of Compliance as to 7-30-2010 order, including further amendment of first paragraph, transmitted to OAL 11-30-2010 and filed 1-11-2011 (Register 2011, No. 2).

**§ 3394.2. Consumer Assistance Program Administration.**

The Consumer Assistance Program shall be administered by the Bureau of Automotive Repair through contracts with dismantlers, licensed smog check test-and-repair stations, and other entities as necessary.

**AUTHORITY:**

**Note:** Authority cited: Sections 44000, 44001.3, 44001.5 and 44002, Health and Safety Code. Reference: Sections 44010.5, 44037.1, 44037.2, 44062.1, 44091, 44092, 44093, 44094 and 44095, Health and Safety Code.

**HISTORY**

1. New section filed 12-3-98 as an emergency; operative 12-3-98 (Register 98, No. 49). A Certificate of Compliance must be transmitted to OAL by 4-2-99 or emergency language will be repealed by operation of law on the following day.
2. New section refiled 3-30-99 as an emergency; operative 4-2-99 (Register 99, No. 14). A Certificate of Compliance must be transmitted to OAL by 8-2-99 or emergency language will be repealed by operation of law on the following day.
3. New section refiled 7-26-99 as an emergency; operative 8-2-99 (Register 99, No. 31). A Certificate of Compliance must be transmitted to OAL by 11-30-99 or emergency language will be repealed by operation of law on the following day.
4. Certificate of Compliance as to 7-26-99 order, including amendment of section, transmitted to OAL 11-18-99 and filed 1-3-2000 (Register 2000, No. 1).
5. Amendment of section heading, section and Note filed 6-26-2000 as an emergency; operative 7-1-2000 (Register 2000, No. 26). A Certificate of Compliance must be transmitted to OAL by 10-30-2000 or emergency language will be repealed by operation of law on the following day.
6. Amendment of section heading, section and Note refiled 10-30-2000 as an emergency; operative 10-30-2000 (Register 2000, No. 44). A Certificate of Compliance must be transmitted to OAL by 2-27-2001 or emergency language will be repealed by operation of law on the following day.
7. Certificate of Compliance as to 10-30-2000 order transmitted to OAL 2-9-2001 and filed 3-27-2001 (Register 2001, No. 13).

**§ 3394.3. State Assistance Limits.**

An applicant determined to be eligible under the Consumer Assistance Program may receive the following assistance:

(a) Under the Vehicle Retirement option, payment of one thousand five hundred dollars (\$1,500) for each vehicle retired from operation for vehicle owners that meet income eligibility requirements. All other vehicle owners shall receive one thousand dollars (\$1,000) for each vehicle retired from operation. All vehicles shall be retired from operation at a dismantler operating under contract with the Bureau of Automotive Repair.

(b) Under the Repair Assistance option, vehicle owners that meet income eligibility requirements will receive up to five hundred dollars (\$500) in emissions-related repair services performed at a licensed smog check test-and-repair station operating under contract with the Bureau of Automotive Repair.

**AUTHORITY:**

**Note:** Authority cited: Sections 44001.3, 44001.5 and 44002, Health and Safety Code. Reference: Sections 44001.3, 44015, 44017, 44037.1, 44062.1, 44091, 44092, 44093, 44094 and 44095, Health and Safety Code.

**HISTORY**

1. New section filed 12-3-98 as an emergency; operative 12-3-98 (Register 98, No. 49). A Certificate of Compliance must be transmitted to OAL by 4-2-99 or emergency language will be repealed by operation of law on the following day.
2. New section refiled 3-30-99 as an emergency; operative 4-2-99 (Register 99, No. 14). A Certificate of Compliance must be transmitted to OAL by 8-2-99 or emergency language will be repealed by operation of law on the following day.
3. New section; refiled 7-26-99 as an emergency; operative 8-2-99 (Register 99, No. 31). A Certificate of Compliance must be transmitted to OAL by 11-30-99 or emergency language will be repealed by operation of law on the following day.
4. Certificate of Compliance as to 7-26-99 order, including amendment of section, transmitted to OAL 11-18-99 and filed 1-3-2000 (Register 2000, No. 1).
5. Amendment of section heading, repealer and new section, and amendment of Note filed 6-26-2000 as an emergency; operative 7-1-2000 (Register 2000, No. 26). A Certificate of Compliance must be transmitted to OAL by 10-30-2000 or emergency language will be repealed by operation of law on the following day.
6. Amendment of section heading, repealer and new section, and amendment of Note refiled 10-30-2000 as an emergency; operative 10-

30-2000 (Register 2000, No. 44). A Certificate of Compliance must be transmitted to OAL by 2-27-2001 or emergency language will be repealed by operation of law on the following day.

7. Certificate of Compliance as to 10-30-2000 order, including further amendment of subsections (a) and (b), transmitted to OAL 2-9-2001 and filed 3-27-2001 (Register 2001, No. 13).

8. Amendment of subsection (b) filed 10-18-2010; operative 11-17-2010 (Register 2010, No. 43).

9. Change without regulatory effect amending subsection (a) filed 1-27-2011 pursuant to section 100, title 1, California Code of Regulations (Register 2011, No. 4).

10. Amendment filed 3-30-2012; operative 4-29-2012 (Register 2012, No. 13).

**§ 3394.4. Eligibility Requirements.**

(a) In order to participate in the Repair Assistance option of the Consumer Assistance Program, a person must meet the following requirements:

(1) Be the registered owner of the vehicle with vehicle title issued in their name.

(2) The vehicle must be currently registered as operable and all registration fees paid to the Department of Motor Vehicles.

(3) The vehicle owner has not previously participated in the Repair Assistance option for the same vehicle.

(4) Have a household income that is less than or equal to two hundred twenty-five percent (225%) of the federal poverty level, as published in the Federal Register by the United States Department of Health and Human Services.

(5) Pay the total cost of testing and diagnosing the emissions-related failure as co-payment for participating in Repair Assistance. The co-payment shall be paid directly to the station that performs the state subsidized emissions-related repair work under agreement with the bureau.

(6) A vehicle must have failed its biennial Smog Check inspection (aborted, manual mode, and training mode tests do not qualify).

(b) In order to participate in the Vehicle Retirement option of the Consumer Assistance Program, a person must meet the following requirements:

(1) Not have retired another vehicle through the Smog Check Consumer Assistance Program within a preceding twelve-(12) month period.

(2) A joint owner of a vehicle may not retire more than two (2) vehicles through the Consumer Assistance Program within a twelve-(12) month period.

(3) Be the registered owner of the vehicle with vehicle title issued in their name.

(4) A vehicle owner who meets household income level requirements listed in paragraph (4) of subdivision (a) of this section shall receive one thousand five hundred dollars (\$1,500) for each vehicle retired.

(5) A vehicle owner who does not meet household income level requirements listed in paragraph (4) of subdivision (a) of this section shall receive one thousand dollars (\$1,000) for each vehicle retired from operation.

(6) The vehicle must be currently registered as operable and all registration fees paid to the Department of Motor Vehicles.

(7) At the time of application, a vehicle must:

(A) Be currently registered with the Department of Motor Vehicles; or,

(B) Be currently operating under a repair cost waiver or economic hardship extension issued by the Bureau of Automotive Repair; or,

(C) Be currently operating under a Temporary Operating Permit issued by the Department of Motor Vehicles.

(8) Notwithstanding paragraph (7) of subsection (b), at the time of application, a vehicle must:

(A) Have been continuously registered as an operable vehicle with the Department of Motor Vehicles for twenty-four (24) months prior to the postmark date of the application; or

(B) Vehicle is placed in non-operational status pursuant to Vehicle Code Section 4604, et seq., for a total of 60 or fewer days during the previous 24 month registration period, and occurring at least 90 days prior to the postmark date of the application; or

(C) Vehicle registration has lapsed for less than 121 days during the previous 24 month registration period, provided that the vehicle is registered for at least 90 days prior to the postmark date of the application.

(9) A vehicle must have failed the most recent smog check inspection (aborted, manual mode, and training mode tests do not qualify) and such failure is for causes other than an ignition timing adjustment or a failed gas cap functional test.

(10) Be a passenger vehicle, truck, sports utility vehicle (SUV) or van, with a gross vehicle weight rating of 10,000 pounds or less.

(11) Pass a visual inspection conducted by the Bureau or its representative verifying that:

- (A) All doors are present.
- (B) The hood lid is present.
- (C) The dashboard is present.
- (D) The windshield is present.
- (E) At least one side window glass is present.
- (F) The driver's seat is present.
- (G) At least one bumper is present.
- (H) The exhaust system is present.
- (I) All side and/or quarter panels are present.
- (J) At least one headlight, one taillight, and one brake light are present.

(12) Pass an operational inspection conducted by the Bureau or its representative verifying that:

(A) The vehicle is driven under its own power to an approved dismantler site.

(B) The vehicle's engine starts readily through ordinary means without the use of starting fluids or external booster batteries.

(C) The drivability of the vehicle is not affected by any body, steering, or suspension damage.

(D) The vehicle is able to drive forward a minimum distance of ten (10) yards under its own power.

(E) The interior pedals are operational.

(c) This section does not apply to the Enhanced Fleet Modernization Program.

**AUTHORITY:**

**Note:** Authority cited: Sections 44001.3, 44001.5 and 44002, Health and Safety Code; and Section 9882, Business and Professions Code. Reference: Sections 44005, 44010.5, 44011, 44012, 44014.7, 44015, 44017, 44017.1, 44037.1, 44062.1, 44091, 44092, 44093, 44094, 44095 and 44125, Health and Safety Code.

**HISTORY**

1. New section filed 12-3-98 as an emergency; operative 12-3-98 (Register 98, No. 49). A Certificate of Compliance must be transmitted to OAL by 4-2-99 or emergency language will be repealed by operation of law on the following day.

2. New section refiled 3-30-99 as an emergency; operative 4-2-99 (Register 99, No. 14). A Certificate of Compliance must be transmitted to OAL by 8-2-99 or emergency language will be repealed by operation of law on the following day.

3. New section refiled 7-26-99 as an emergency; operative 8-2-99 (Register 99, No. 31). A Certificate of Compliance must be transmitted to OAL by 11-30-99 or emergency language will be repealed by operation of law on the following day.

4. Certificate of Compliance as to 7-26-99 order, including amendment of section and Note, transmitted to OAL 11-18-99 and filed 1-3-2000 (Register 2000, No. 1).

5. Amendment of section heading, section and Note filed 6-26-2000 as an emergency; operative 7-1-2000 (Register 2000, No. 26). A Certificate of Compliance must be transmitted to OAL by 10-30-2000 or emergency language will be repealed by operation of law on the following day.

6. Amendment of section heading, section and Note refiled 10-30-2000 as an emergency, including further amendment of Note; operative 10-30-2000 (Register 2000, No. 44). A Certificate of Compliance must be transmitted to OAL by 2-27-2001 or emergency language will be repealed by operation of law on the following day.

7. Certificate of Compliance as to 10-30-2000 order, including further amendment of section and Note, transmitted to OAL 2-9-2001 and filed 3-27-2001 (Register 2001, No. 13).

8. Amendment of subsection (b)(1) filed 2-26-2002 as an emergency; operative 2-26-2002 (Register 2002, No. 9). A Certificate of Compliance must be transmitted to OAL by 6-26-2002 or emergency language will be repealed by operation of law on the following day.

9. Certificate of Compliance as to 2-26-2002 order transmitted to OAL 6-13-2002 and filed 7-2-2002 (Register 2002, No. 27).

10. Amendment of section and Note filed 7-31-2006; operative 7-31-2006 pursuant to Government Code section 11343.4 (Register 2006, No. 31).

11. Redesignation and amendment of former subsection (c)(4) as subsection (c)(4)(A), new subsection (c)(4)(B), redesignation and amendment of former subsection (c)(6) as subsection (c)(6)(A) and new subsection (c)(6)(B) filed 8-12-2008; operative 8-12-2008 pursuant to Government Code section 11343.4 (Register 2008, No. 33).

12. Amendment of section and Note filed 7-30-2010 as an emergency; effective 7-30-2010. Emergency regulation shall become operative on the effective date of the Air Resources Board's AB 118 Enhanced Fleet Modernization Program regulations, 13 CCR division 3, chapter 13, sections 2620-2630. A Certificate of Compliance must be transmitted to OAL by 1-26-2011 or emergency language will be repealed by operation of law on the following day (Register 2010, No. 31).

13. Amendment filed 10-18-2010; operative 11-17-2010 (Register 2010, No. 43).

14. Certificate of Compliance as to 7-30-2010 order, including new subsection (b)(5)(C) and further amendment of subsections (b)(5)(B) and (c)(6), transmitted to OAL 11-30-2010 and filed 1-11-2011 (Register 2011, No. 2).

15. Change without regulatory effect amending section filed 1-27-2011 pursuant to section 100, title 1, California Code of Regulations (Register 2011, No. 4).

16. Amendment filed 3-30-2012; operative 4-29-2012 (Register 2012, No. 13).

**§ 3394.5. Ineligible Vehicles.**

(a) The following vehicles are not eligible for participation in the Repair Assistance and Vehicle Retirement options of the Consumer Assistance Program:

(1) A vehicle undergoing a transfer of ownership.

(2) A vehicle being initially registered or re-registered in California.

(3) A direct import vehicle being initially registered in California.

(4) A vehicle powered by alternate fuel, unless a Bureau Referee label is posted on the vehicle.

(5) A specially constructed vehicle, unless a Bureau Referee label is posted on the vehicle.

(6) A dismantled or total loss salvaged vehicle that has not been re-registered pursuant to Section 11519 of the Vehicle Code.

(7) A vehicle operated by a fleet licensed and registered pursuant to Section 44020 of the Health and Safety Code.

(8) A vehicle registered to a non-profit organization or a business.

(9) A vehicle that is untestable on a BAR-97 Emissions Inspection System (EIS) or OBD Inspection System (OIS).

(b) Notwithstanding subsection (a), the following vehicles are not eligible for participation in the Repair Assistance option:

(1) A vehicle with a tampered emissions control system.

(2) A vehicle that has failed its Smog Check inspection that is required for an initial registration, upon transfer of ownership, or registration pursuant to Vehicle Code section 4000.1.

(c) Notwithstanding subsection (a), a vehicle with a tampered emissions control system where the tampered system is the cause for failing the smog check inspection is not eligible for participation in the Vehicle Retirement option.

(d) This section does not apply to the Enhanced Fleet Modernization Program.

**AUTHORITY:**

**Note:** Authority cited: Sections 44000, 44001.3, 44001.5, 44002, 44091, 44092, 44093, 44094 and 44095, Health and Safety Code. Reference: Sections 44011, 44015, 44017, 44020, 44037.1, 44091, 44092, 44093, 44094, 44095 and 44125, Health and Safety Code; and Section 11519, Vehicle Code.

**HISTORY**

1. New section filed 12-3-98 as an emergency; operative 12-3-98 (Register 98, No. 49). A Certificate of Compliance must be transmitted to OAL by 4-2-99 or emergency language will be repealed by operation of law on the following day.
2. New section refiled 3-30-99 as an emergency; operative 4-2-99 (Register 99, No. 14). A Certificate of Compliance must be transmitted to OAL by 8-2-99 or emergency language will be repealed by operation of law on the following day.
3. New section refiled 7-26-99 as an emergency; operative 8-2-99 (Register 99, No. 31). A Certificate of Compliance must be transmitted to OAL by 11-30-99 or emergency language will be repealed by operation of law on the following day.
4. Certificate of Compliance as to 7-26-99 order, including amendment of section heading and repealer and new section, transmitted to OAL 11-18-99 and filed 1-3-2000 (Register 2000, No. 1).
5. Amendment of section heading, repealer and new section, and amendment of Note filed 6-26-2000 as an emergency; operative 7-1-2000 (Register 2000, No. 26). A Certificate of Compliance must be transmitted to OAL by 10-30-2000 or emergency language will be repealed by operation of law on the following day.
6. Amendment of section heading, repealer and new section, and amendment of Note refiled 10-30-2000 as an emergency, including further amendment of Note; operative 10-30-2000 (Register 2000, No. 44). A Certificate of Compliance must be transmitted to OAL by 2-27-2001 or emergency language will be repealed by operation of law on the following day.
7. Certificate of Compliance as to 10-30-2000 order, including further amendment of section and Note, transmitted to OAL 2-9-2001 and filed 3-27-2001 (Register 2001, No. 13).
8. Change without regulatory effect amending subsection (a)(9) filed 10-11-2006 pursuant to section 100, title 1, California Code of Regulations (Register 2006, No. 41).
9. Amendment of subsection (a)(6), new subsection (b) and amendment of Note filed 7-30-2010 as an emergency; effective 7-30-2010. Emergency regulation shall become operative on the effective date of the Air Resources Board's AB 118 Enhanced Fleet Modernization Program regulations, 13 CCR division 3, chapter 13, sections 2620-2630. A

Certificate of Compliance must be transmitted to OAL by 1-26-2011 or emergency language will be repealed by operation of law on the following day (Register 2010, No. 31).

10. Certificate of Compliance as to 7-30-2010 order transmitted to OAL 11-30-2010 and filed 1-11-2011 (Register 2011, No. 2).

11. Change without regulatory effect amending subsection (a)(1) filed 1-27-2011 pursuant to section 100, title 1, California Code of Regulations (Register 2011, No. 4).

12. Amendment filed 3-30-2012; operative 4-29-2012 (Register 2012, No. 13).

13. Amendment of subsection (a)(9) filed 5-2-2013; operative 7-1-2013 (Register 2013, No. 18).

**§ 3394.6. Application and Documentation Requirements for the Consumer Assistance Program.**

(a) In order to participate in the Consumer Assistance Program, the applicant shall meet the requirements pursuant to 3394.4 et seq. and submit a completed application, CAP/APP (07/12), which is hereby incorporated by reference, and required documentation to the Department or its designee with original signature(s).

(b) To qualify based on income level, the applicant must certify under penalty of perjury that he or she has a household income that is less than or equal to two hundred twenty-five percent (225%) of the federal poverty level, as published in the Federal Register by the United States Department of Health and Human Services. Prior to approving the application, the bureau will periodically and randomly require the applicant to provide a copy of one of the following documents, as applicable:

(1) A letter from the issuing agency stating that the applicant receives any of the following benefits:

- (A) Supplemental Security Income (SSI);
- (B) State Supplemental Payments (SSP);
- (C) Temporary Assistance for Needy Families (TANF);
- (D) California Work Opportunity and Responsibility to Kids (CalWORKS);
- (E) General Assistance (GA) or General Relief (GR);

or

(F) Publicly subsidized medical coverage, such as or Medi-Cal.

(2) The applicant's state or federal income tax form (Form 540 or 1040) filed in the most recent tax year; and a paycheck stub reflecting year-to-date earnings, hours worked, and hourly wage of the applicant; or

(3) An unemployment, veterans benefits, or disability check issued to the applicant within the last sixty (60) days; or

(4) A monthly bank statement issued to the applicant within the last sixty (60) days reflecting direct deposit of Social Security or Public Assistance; or

(5) Other documentation satisfactory to the Department.

**AUTHORITY:**

**Note:** Authority cited: Sections 44001.5, 44002, 44091 and 44094, Health and Safety Code; and Section 9882, Business and Professions Code. Reference: Sections 44001.3, 44005, 44010.5, 44011, 44012, 44014, 44014.2, 44015, 44017, 44017.1, 44062.1, 44092, 44093, 44094 and 44095, Health and Safety Code.

**HISTORY**

1. Renumbering of former section 3340.9 to section 3394.6, including amendment of section heading, repealer and new section, amendment of Note, and amendment of Form CAP-APP filed 6-26-2000 as an emergency; operative 7-1-2000 (Register 2000, No. 26). A Certificate of

Compliance must be transmitted to OAL by 10-30-2000 or emergency language will be repealed by operation of law on the following day.

2. Change without regulatory effect amending subsection (a) and updating Form CAP-APP filed 9-21-2000 pursuant to section 100, title 1, California Code of Regulations (Register 2000, No. 38).

3. Renumbering of former section 3340.9 to section 3394.6, amendment of section heading, repealer and new section, amendment of Note, and amendment of Form CAP-APP refiled 10-30-2000 as an emergency, including further amendment of Note; operative 10-30-2000 (Register 2000, No. 44). A Certificate of Compliance must be transmitted to OAL by 2-27-2001 or emergency language will be repealed by operation of law on the following day.

4. Certificate of Compliance as to 10-30-2000 order, including further amendment of subsections (a)-(b)(1), repealer of subsections (b)(2)-(6), subsection renumbering, and amendment of Form CAP-APP, transmitted to OAL 2-9-2001 and filed 3-27-2001 (Register 2001, No. 13).

5. Change without regulatory effect amending subsection (a) and form CAP-APP filed 8-15-2001 pursuant to section 100, title 1, California Code of Regulations (Register 2001, No. 33).

6. Amendment of subsection (a), new subsection (b)(2)(A)4., subsection renumbering, amendment of CAP/APP form and amendment of Note filed 2-26-2002 as an emergency; operative 2-26-2002 (Register 2002, No. 9). A Certificate of Compliance must be transmitted to OAL by 6-26-2002 or emergency language will be repealed by operation of law on the following day.

7. Certificate of Compliance as to 2-26-2002 order transmitted to OAL 6-13-2002 and filed 7-2-2002 (Register 2002, No. 27).

8. Amendment of subsection (a) and Note and repealer and new form CAP/APP (removed from print and incorporated by reference) filed 7-31-2006; operative 7-31-2006 pursuant to Government Code section 11343.4 (Register 2006, No. 31).

9. Change without regulatory effect repealing and readopting new CAP/APP form (incorporated by reference) and amending subsection (a) filed 11-2-2006 pursuant to section 100, title 1, California Code of Regulations (Register 2006, No. 44).

10. Change without regulatory effect amending subsections (a) and (b) (1)(A)6. and form PPD 05\_046 CAP/APP (incorporated by reference) filed 10-1-2007 pursuant to section 100, title 1, California Code of Regulations (Register 2007, No. 40).

11. Change without regulatory effect amending subsection (a) filed 8-13-2008 pursuant to section 100, title 1, California Code of Regulations (Register 2008, No. 33).

12. Amendment of section heading and section filed 7-30-2010 as an emergency; effective 7-30-2010. Emergency regulation shall become operative on the effective date of the Air Resources Board's AB 118 Enhanced Fleet Modernization Program regulations, 13 CCR division 3, chapter 13, sections 2620-2630. A Certificate of Compliance must be transmitted to OAL by 1-26-2011 or emergency language will be repealed by operation of law on the following day (Register 2010, No. 31).

13. Amendment of subsection (a) filed 10-18-2010; operative 11-17-2010 (Register 2010, No. 43).

14. Certificate of Compliance as to 7-30-2010 order, including further amendment of subsection (a), transmitted to OAL 11-30-2010 and filed 1-11-2011 (Register 2011, No. 2).

15. Change without regulatory effect amending subsections (a) and (b) (2) filed 1-27-2011 pursuant to section 100, title 1, California Code of Regulations (Register 2011, No. 4).

16. Amendment filed 3-30-2012; operative 4-29-2012 (Register 2012, No. 13).

17. Change without regulatory amending subsection (a) filed 9-25-2012 pursuant to section 100, title 1, California Code of Regulations (Register 2012, No. 39).

### § 3394.7. Application and Documentation Requirements for the Enhanced Fleet Modernization Program.

In order to participate in the Enhanced Fleet Modernization Program, the applicant shall meet the requirements pursuant to Title 13, Chapter 13, Article 2, California Code of Regulations, submit a completed application as prescribed in section 3394.6 (a) and required documentation to the Department or its designee with original signature(s).

#### AUTHORITY:

**Note:** Authority cited: Sections 44001.5 and 44125, Health and Safety Code; and Section 9882, Business and Professions Code. Reference: Section 44126, Health and Safety Code.

#### HISTORY

1. New section filed 7-30-2010 as an emergency; effective 7-30-2010. Emergency regulation shall become operative on the effective date of the Air Resources Board's AB 118 Enhanced Fleet Modernization Program regulations, 13 CCR division 3, chapter 13, sections 2620-2630. A Certificate of Compliance must be transmitted to OAL by 1-26-2011 or emergency language will be repealed by operation of law on the following day (Register 2010, No. 31).

2. Certificate of Compliance as to; 7-30-2010 order, including amendment of section, transmitted to OAL 11-30-2010 and filed 1-11-2011 (Register 2011, No. 2).

3. Change without regulatory effect amending section filed 1-27-2011 pursuant to section 100, title 1, California Code of Regulations (Register 2011, No. 4).

4. Amendment filed 3-30-2012; operative 4-29-2012 (Register 2012, No. 13).

## ARTICLE 11.1.

### Citations and Administrative Fines for Licensees

§ 3394.25. Authority to Issue Citations and Administrative Fines.

§ 3394.26. Administrative Fine Amounts.

§ 3394.27. Compliance with Citations/Orders of Abatement.

#### § 3394.25. Authority to Issue Citations and Administrative Fines.

The director or his/her designee is authorized to determine when and against whom a citation will be issued and to issue citations containing orders of abatement and/or administrative fines for violations by a licensee or contractor of Health and Safety Code section 44000 et seq. and any regulations adopted pursuant thereto.

#### AUTHORITY:

**Note:** Authority cited: Section 9882, Business and Professions Code. Reference: Sections 44002 and 44050, Health and Safety Code.

#### HISTORY

1. New article 11.1 (sections 3394.25-3394.27) and section filed 7-10-2012; operative 7-10-2012 pursuant to Government Code section 11343.4 (Register 2012, No. 28).

#### § 3394.26. Administrative Fine Amounts.

(a) The minimum and maximum administrative fine amounts are established in Table I, Administrative Fine Schedule. If a citation lists multiple violations arising from an inspection or repair on a single vehicle the total penalties assessed shall not exceed five thousand dollars (\$5,000) pursuant to Health and Safety Code section 44052.

(b) Penalties exceeding five thousand dollars (\$5,000) for inspections and repairs that arise from multiple vehicles shall be assessed in separate citations.

TABLE I  
ADMINISTRATIVE FINE SCHEDULE

<i>HEALTH &amp; SAFETY CODE (H&amp;S) OR CALIFORNIA CODE OF REGULATIONS(CCR) SECTION</i>	<i>ADMINISTRATIVE FINE AMOUNT</i>	
<i>H&amp;S SECTIONS</i>	<i>MINIMUM</i>	<i>MAXIMUM</i>
§ 44011.3	\$250	\$1000

*HEALTH & SAFETY  
CODE (H&S) OR  
CALIFORNIA CODE OF  
REGULATIONS(CCR)  
SECTION*

*ADMINISTRATIVE FINE  
AMOUNT*

<i>H&amp;S SECTIONS</i>	<i>MINIMUM</i>	<i>MAXIMUM</i>
§ 44012	\$1000	\$5000
§ 44014.4	\$750	\$3000
§ 44014.5	\$750	\$3000
§ 44015	\$1000	\$5000
§ 44015.5	\$1000	\$5000
§ 44016	\$1000	\$5000
§ 44017	\$1000	\$5000
§ 44017.3	\$250	\$1000
§ 44017.4	\$1000	\$5000
§ 44032	\$1000	\$5000
§ 44033(b)	\$750	\$3000
§ 44033(c)	\$750	\$3000
§ 44033(d)	\$750	\$3000
§ 44035	\$1000	\$5000
§ 44036(b)(1)	\$750	\$3000
§ 44036.5(b)	\$1000	\$5000
<i>CCR SECTIONS</i>	<i>MINIMUM</i>	<i>MAXIMUM</i>
§ 3303.3	\$250	\$1000
§ 3340.15	\$250	\$1000
§ 3340.16	\$750	\$3000
§ 3340.16.4	\$750	\$3000
§ 3340.16.5	\$750	\$3000
§ 3340.17	\$1000	\$5000
§ 3340.23	\$750	\$3000
§ 3340.30(a)	\$1000	\$5000
§ 3340.30(b)	\$250	\$1000
§ 3340.30(c)	\$250	\$1000
§ 3340.35	\$1000	\$5000
§ 3340.41(a)	\$250	\$1000
§ 3340.41(b)	\$750	\$3000
§ 3340.41(c)	\$1000	\$5000
§ 3340.41(d)	\$1000	\$5000
§ 3340.41(f)	\$1000	\$5000
§ 3340.41.3	\$250	\$1000
§ 3340.42	\$1000	\$5000
§ 3340.42.2	\$1000	\$5000
§ 3340.45	\$1000	\$5000
§ 3340.50(e)	\$750	\$3000
§ 3340.50(f)	\$750	\$3000
§ 3340.50(g)	\$250	\$1000
§ 3340.50(h)	\$250	\$1000
§ 3353	\$250	\$1000

**AUTHORITY:**

**Note:** Authority cited: Section 9882, Business and Professions Code. Reference: Sections 44002, 44050 and 44052, Health and Safety Code.

**HISTORY**

1. New section filed 7-10-2012; operative 7-10-2012 pursuant to Government Code section 11343.4 (Register 2012, No. 28).

**§ 3394.27. Compliance with Citations/Orders of Abatement.**

(a) If a cited person who has been issued an order of abatement is unable to complete the correction within the time set forth in the citation because of conditions beyond his or her control after the exercise of reasonable diligence, the cited person may request an extension of time in which to complete the correction from the director or his/her designee. Such a request is subject to approval by the director or his/her designee and shall be in writing and made within the time set forth for abatement.

(b) If administrative fine(s) are not paid after a citation has become final, the administrative fine(s) shall be added to the cited person's license or registration renewal fee. A license or registration shall not be renewed without payment of the renewal fee and all administrative fines.

**AUTHORITY:**

**Note:** Authority cited: Sections 9882, Business and Professions Code. Reference: Sections 44002, 44031.5 and 44050, Health and Safety Code.

**HISTORY**

1. New section filed 7-10-2012; operative 7-10-2012 pursuant to Government Code section 11343.4 (Register 2012, No. 28).

**ARTICLE 11.2.  
Administrative Citations and Fines for  
Unlicensed Activity**

- § 3394.40. Authority to Issue Citations and Fines for Unlicensed Practice.
- § 3394.41. Citation Format.
- § 3394.42. Citations for Unlicensed Practice.
- § 3394.43. Fine Amounts for Unlicensed Practice.
- § 3394.44. Compliance with Citation/Order of Abatement.
- § 3394.45. Contested Citations and Request for a Hearing or Informal Citation Conference.
- § 3394.46. Disconnection of Telephone Service.

**§ 3394.40. Authority to Issue Citations and Fines for Unlicensed Practice.**

The bureau chief or his/her designee is authorized to determine when and against whom a citation will be issued and to issue citations containing orders of abatement and fines for violations by any unlicensed person who is acting in the capacity of a licensee or registrant.

**AUTHORITY:**

**Note:** Authority cited: Section 9882, Business and Professions Code. Reference: Sections 125.9, 148, 149 and 302(d), Business and Professions Code.

**HISTORY**

1. New article 11.2 (sections 3394.40-3394.46) and section filed 9-27-2011; operative 10-27-2011 (Register 2011, No. 39).

**§ 3394.41. Citation Format.**

A citation shall be issued whenever any fine is levied or any order of abatement is issued. Each citation shall be in writing and shall describe with particularity the nature and facts of each violation, including a reference to the statute(s) and/or regulation(s) alleged to have been violated. The citation shall inform the cited person of the right to contest the citation. The citation shall be served upon the cited person personally or by registered mail pursuant to Section 11505(c) of the Government Code.



**AUTHORITY:**

**Note:** Authority cited: Section 9882, Business and Professions Code. Reference: Sections 125.9, 148, 149 and 302(d), Business and Professions Code; Section 11505(c), Government Code.

**HISTORY**

1. New section filed 9-27-2011; operative 10-27-2011 (Register 2011, No. 39).

**§ 3394.42. Citations for Unlicensed Practice.**

The bureau chief or his/her designee is authorized to determine when and against whom a citation will be issued and to issue citations containing orders of abatement and fines against persons, as defined in Section 302(d) of Business and Professions Code, who are performing or who have performed services for which a license or registration is required under the statutes and regulations enforced by the Bureau of Automotive Repair. Each citation shall contain an order of abatement. Where appropriate, the bureau chief or his/her designee shall levy a fine against any unlicensed person who is acting in the capacity of a licensee or registrant. Sanctions authorized under Article 11.2 Administrative Citations and Fines for Unlicensed Activity shall be separate from and in addition to any other civil or criminal actions.

**AUTHORITY:**

**Note:** Authority cited: Section 9882, Business and Professions Code. Reference: Sections 125.9, 148, 149 and 302(d), Business and Professions Code.

**HISTORY**

1. New section filed 9-27-2011; operative 10-27-2011 (Register 2011, No. 39).

**§ 3394.43. Fine Amounts for Unlicensed Practice.**

(a) The bureau may use the authority pursuant to Business and Professions Code section 148, to issue a citation to a person with an expired license or registration. The bureau shall first issue an order of abatement without a fine that shall contain, but is not limited to the following:

(1) Information that the licensee shall immediately cease all work and/or any work in progress that requires a valid license or registration.

(2) Information that license renewal fee and any delinquency or other fees must be fully paid within 30 calendar days, after which time the bureau may assess fines pursuant to Business and Professions Code section 148.

(3) Notice that continuing to operate without a valid license or registration may result in citation, fine, and/or other disciplinary action.

(b) The bureau may assess an administrative fine to an unlicensed person acting in the capacity of a licensee or registrant that has not applied for and obtained a valid license.

(c) The bureau may assess administrative fines of up to five thousand dollars (\$5,000) for each violation in addition to any criminal penalties. The bureau shall base its assessment and amount of the fine on the following circumstances:

(1) The nature, gravity, severity, and seriousness of the violation.

(2) The persistence of the violation.

(3) The good faith or willfulness of the violator to cooperate with the bureau.

(4) The history of previous violations by that violator, including the commission of numerous and repeated violations.

(5) The failure to perform work for which money was received.

(6) The making of any false or misleading statement in order to induce a person to authorize repair work or pay money.

(7) The failure to make restitution to consumers affected by the violation.

(8) The extent to which the violator has mitigated or attempted to mitigate any damage or injury caused by the violation.

(9) The degree of incompetence or negligence in the performance of duties and responsibilities.

(10) The purposes and goals of this chapter and other matters as may be appropriate.

**AUTHORITY:**

**Note:** Authority cited: Section 9882, Business and Professions Code. Reference: Sections 125, 125.9, 148, 149 and 302(d), Business and Professions Code.

**HISTORY**

1. New section filed 9-27-2011; operative 10-27-2011 (Register 2011, No. 39).

**§ 3394.44. Compliance with Citation/Order of Abatement.**

(a) If a cited person who has been issued an order of abatement is unable to complete the correction within the time set forth in the citation because of conditions beyond his or her control after the exercise of reasonable diligence, the cited person may request an extension of time in which to complete the correction from the bureau chief. Such a request shall be in writing and made within the time set forth for abatement.

(b) If a citation is not contested, or if the citation is contested and the cited person does not prevail, failure to abate the violation or to pay the assessed fine within the time allowed shall constitute a violation and a failure to comply with the citation or order of abatement.

(c) Failure to timely comply with an order of abatement or pay an assessed fine may result in disciplinary action being taken by the bureau or other appropriate judicial action being taken against the cited person.

(d) If a fine is not paid after a citation has become final, the fine shall be added to the cited person's license or registration renewal fee. A license or registration shall not be renewed without payment of the renewal fee and fine.

(e) Nothing in this section shall be construed as permission for any person to operate or continue to operate without a valid license or registration.

**AUTHORITY:**

**Note:** Authority cited: Section 9882, Business and Professions Code. Reference: Sections 125.9, 148, 149 and 302(d), Business and Professions Code.

**HISTORY**

1. New section filed 9-27-2011; operative 10-27-2011 (Register 2011, No. 39).

**§ 3394.45. Contested Citations and Request for a Hearing or Informal Citation Conference.**

(a) In addition to requesting an administrative hearing as provided for in subdivision (b)(4) of Section 125.9 of Business and Professions Code, the cited person may request an informal conference to review the acts charged in the citation. A request for an informal conference shall be made in writing, within ten (10) days after service of the citation, to the bureau chief or his/her designee.

(b) The bureau chief or his/her designee shall hold, within sixty (60) days from the receipt of the request, an informal conference with the cited person. At the conclusion of the informal conference, the bureau chief or his/her designee may affirm, modify or dismiss the citation, including any fine levied, order of abatement or order of correction issued. The bureau chief or his/her designee shall state in writing the reasons for his or her action and transmit within fifteen (15) days a copy of his or her findings and decision to the cited person. Unless an administrative hearing as provided for in subdivision (b)(4) of Section 125.9 of Business and Professions Code was requested in a timely manner, an informal conference decision which affirms the citation shall be deemed to be a final order with regard to the citation issued, including the fine levied and the order of abatement.

(c) If the citation, including any fine levied or order of abatement or correction, is modified, the citation originally issued shall be considered withdrawn and a new citation issued. If the cited person desires a hearing to contest the new citation, he or she shall make a request in writing, within ten (10) days of receipt of the informal conference decision, to the bureau chief or his/her designee. The hearing shall be conducted as provided for in subdivision (b)(4) of Section 125.9 of Business and Professions Code. A cited person may not request an informal conference for a citation which has been modified following an informal conference.

**AUTHORITY:**

**Note:** Authority cited: Section 9882, Business and Professions Code. Reference: Sections 125.9, 148, 149 and 302(d), Business and Professions Code.

**HISTORY**

1. New section filed 9-27-2011; operative 10-27-2011 (Register 2011, No. 39).

**§ 3394.46. Disconnection of Telephone Service.**

Nothing in this section shall preclude the bureau from using the provisions of Section 149 of Business and Professions Code in addition to any citation issued to any person.

**AUTHORITY:**

**Note:** Authority cited: Section 9882, Business and Professions Code. Reference: Sections 125.9, 148, 149 and 302(d), Business and Professions Code.

**HISTORY**

1. New section filed 9-27-2011; operative 10-27-2011 (Register 2011, No. 39).

**ARTICLE 12.  
Miscellaneous**

- § 3395. Criteria for Rehabilitation.
- § 3395.1. Conditions to Insure Future Compliance.
- § 3395.2. Criteria for Denial, Suspension, or Revocation of a Registration.

- § 3395.3. Manufacture, Sale, or Installation of Defective Vehicle Parts.
- § 3395.4. Disciplinary Guidelines.

**§ 3395. Criteria for Rehabilitation.**

(a) When considering the denial of a license or a registration under Section 480 of the Business and Professions Code, the bureau, in evaluating the rehabilitation of the applicant, will consider the following criteria:

(1) The nature and severity of the act(s) or crime(s) under consideration as grounds for denial.

(2) Evidence of any act(s) committed subsequent to the act(s) or crime(s) under consideration as grounds for denial which also could be considered as grounds for denial under Section 480 of the Business and Professions Code.

(3) The time that has elapsed since commission of the act(s) or crime(s) referred to in subdivision (1) or (2).

(4) The extent to which the applicant has complied with any terms of parole, probation, restitution, or any other sanctions lawfully imposed against the applicant.

(5) Evidence, if any, of rehabilitation submitted by the applicant.

(b) When considering the suspension or revocation of a license or a registration on the grounds that the licensee or registrant has been convicted of a crime, the bureau, in evaluating the rehabilitation of such person, will consider the following criteria:

(1) Nature and severity of the act(s) or offense(s).

(2) Total criminal record.

(3) The time that has elapsed since commission of the act(s) or offense(s).

(4) Whether the licensee or registrant has complied with any terms of parole, probation, restitution, or any other sanctions lawfully imposed against the licensee or registrant.

(5) If applicable, evidence of expungement proceedings pursuant to Section 1203.4 of the Penal Code.

(6) Evidence, if any, of rehabilitation submitted by the licensee or registrant.

(c) When considering a petition for reinstatement of a license or a registration, the bureau shall evaluate evidence of rehabilitation submitted by the petitioner, considering those criteria specified in subsection (b).

**AUTHORITY:**

**Note:** Authority cited: Sections 9882 and 9884.19, Business and Professions Code. Reference: Sections 475, 480, 482 and 9884.19, Business and Professions Code.

**HISTORY**

1. New Article 11 (Sections 3395 and 3396) filed 7-24-73 as an emergency; effective upon filing (Register 73, No. 30).

2. Certificate of Compliance filed 9-14-73 (Register 73, No. 37). 3. Amendment filed 5-8-75; effective thirtieth day thereafter (Register 75, No. 19).

4. Amendment filed 12-23-76; effective thirtieth day thereafter (Register 76, No. 52).

5. Renumbering of former Article 11 (Section 3395) to new Article 10 (Sections 3395-3395.3), and amendment of Section 3395 filed 2-22-83; effective thirtieth day thereafter (Register 83, No. 9).

6. Renumbering of former article 10 to new article 11 (sections 3395-3395.3) filed 4-23-97 as an emergency; operative 4-23-97 (Register 97, No. 17). A Certificate of Compliance must be transmitted to OAL by 8-21-97 or emergency language will be repealed by operation of law on the following day.

7. Certificate of Compliance as to 4-23-97 order transmitted to OAL 8-19-97 and filed 9-30-97 (Register 97, No. 40).

8. Renumbering of former article 11 to new article 12 (sections 3395-3395.4) filed 12-3-98 as an emergency; operative 12-3-98 (Register 98, No. 49). A Certificate of Compliance must be transmitted to OAL by 4-2-99 or emergency language will be repealed by operation of law on the following day.

9. Renumbering of former article 11 to new article 12 (sections 3395-3395.4) refiled 3-30-99 as an emergency; operative 4-2-99 (Register 99, No. 14). A Certificate of Compliance must be transmitted to OAL by 8-2-99 or emergency language will be repealed by operation of law on the following day.

10. Renumbering of former article 11 to new article 12 (sections 3395-3395.4) refiled 7-26-99 as an emergency; operative 8-2-99 (Register 99, No. 31). A Certificate of Compliance must be transmitted to OAL by 11-30-99 or emergency language will be repealed by operation of law on the following day.

11. Certificate of Compliance as to 7-26-99 order transmitted to OAL 11-18-99 and filed 1-3-2000 (Register 2000, No. 1).

#### § 3395.1. Conditions to Insure Future Compliance.

A person whose registration has previously been refused validation or who has committed acts prohibited by Section 9884.7 of the Act shall, as a condition to any subsequent consideration of an application for validation of his registration, submit evidence which is deemed to be sufficient to establish his rehabilitation. The evidence of rehabilitation shall be submitted in addition to any other information which may be required by the bureau.

##### AUTHORITY:

**Note:** Authority cited: Sections 482, 9882 and 9884.2, Business and Professions Code. Reference: Sections 482, 486 and 9884.2, Business and Professions Code.

##### HISTORY

1. Renumbering and amendment of former Section 3352 to Section 3395.1 filed 2-22-83; effective thirtieth day thereafter (Register 83, No. 9).

#### § 3395.2. Criteria for Denial, Suspension, or Revocation of a Registration.

A crime or act shall be considered to be substantially related to the qualifications, functions, or duties of a registrant if to a substantial degree it shows that the registrant is presently or potentially unfit to perform the functions authorized by the registration in a manner consistent with the public health, safety, or welfare. Such crimes or acts shall include, but not be limited to, any violation of the provisions of Article 3 of Chapter 20.3 of Division 3 of the Business and Professions Code.

##### AUTHORITY:

**Note:** Authority cited: Sections 9882 and 9884.19, Business and Professions Code. Reference: Sections 475-491, Business and Professions Code.

##### HISTORY

1. Renumbering and amendment of former Section 3357 to Section 3395.2 filed 2-22-83; effective thirtieth day thereafter (Register 83, No. 9).

#### § 3395.3. Manufacture, Sale, or Installation of Defective Vehicle Parts.

Any violation of Section 12000 through 12002 of the Vehicle Code shall be cause for disciplinary action against the registration of an automotive repair dealer.

##### AUTHORITY:

**Note:** Authority cited: Sections 9882 and 9884.19, Business and Professions Code. Reference: Section 9884.7, Business and Professions Code; and Sections 12000-12002, Vehicle Code.

##### HISTORY

1. Renumbering and amendment of former Section 3374.1 to Section 3395.3 filed 2-22-83; effective thirtieth day thereafter (Register 83, No. 9).

#### § 3395.4. Disciplinary Guidelines.

In reaching a decision on a disciplinary action under the Administrative Procedure Act (Government Code Section 11400 et seq.), including formal hearings conducted by the Office of Administrative Hearing, the Bureau of Automotive Repair shall consider the disciplinary guidelines entitled "Guidelines for Disciplinary Penalties and Terms of Probation" [May, 1997] which are hereby incorporated by reference. The "Guidelines for Disciplinary Penalties and Terms of Probation" are advisory. Deviation from these guidelines and orders, including the standard terms of probation, is appropriate where the Bureau of Automotive Repair in its sole discretion determines that the facts of the particular case warrant such deviation--for example: the presence of mitigating factors; the age of the case; evidentiary problems.

##### AUTHORITY:

**Note:** Authority cited: Section 9882, Business and Professions Code; and Sections 11400.20 and 11400.21, Government Code. Reference: Sections 11400.20, 11400.21 and 11425.50(e), Government Code.

##### HISTORY

1. New section filed 7-7-97; operative 7-7-97 pursuant to section 100, title 1, California Code of Regulations (Register 97, No. 28).

## DIVISION 33.1.

### Arbitration Certification Program

#### ARTICLE 1.

§ 3396.1. Definitions.

§ 3397. Scope of Regulations.

#### § 3396.1. Definitions.

(a) "Applicable law" means the portions of the Song-Beverly Consumer Warranty Act (Civil Code Sections 1790-1795.7) that pertain to express and implied warranties and remedies for breach; the portions of Division 2 (commencing with Section 2101) of the Commercial Code that pertain to express and implied warranties and remedies for breach; the portions of Sections 43204, 43205 and 43205.5 of the Health and Safety Code that pertain to automobile emissions warranties; Chapter 9 of Division 1 of the Business and Professions Code, pertaining to certification of dispute resolution processes, and this subchapter.

(b) "Applicant" means a manufacturer seeking certification of an arbitration program sponsored and used by the manufacturer, or an arbitration program and a manufacturer jointly seeking certification of an arbitration program used by the manufacturer.

(c) "Arbitration program" means a "dispute resolution process," as that term is used in Civil Code Sections 1793.22(c)-(d) and 1794(e), and Business and Professions Code Section 472, established to resolve disputes involving written warranties on new motor vehicles. The term includes an "informal dispute settlement procedure," as that term is used in Section 703.1(e) of Title 16 of the Code of Federal Regulations, established to resolve disputes involving written warranties on new motor vehicles. The term includes an "informal dispute settlement mechanism," as that term is used in 15 U.S.C. 2310(a)(1), and an "informal dispute settlement procedure," as that

term is used in Section 703.1(e) of Title 16 of the Code of Federal Regulations, established to resolve disputes involving written warranties on new motor vehicles. The term includes those components of a program for which the manufacturer has responsibilities under Article 2 of this subchapter.

(d) “Arbitrator” means the person or persons within an arbitration program who actually decide disputes.

(e) “Arbitration Certification Program” means the Arbitration Certification Program of the Department of Consumer Affairs.

(f) “Certification” means a determination by the Arbitration Certification Program, made pursuant to this subchapter, that an arbitration program is in substantial compliance with Civil Code Section 1793.22(d), Chapter 9 of Division 1 of the Business and Professions Code, and this subchapter.

(g) “Consumer” means any individual who buys or leases a new motor vehicle from a person (including any entity) engaged in the business of manufacturing, distributing, selling, or leasing new motor vehicles at retail. The term includes a lessee for a term exceeding four months, whether or not the lessee bears the risk of the vehicle’s depreciation. The term includes any individual to whom the vehicle is transferred during the duration of a written warranty or under applicable state law to enforce the obligations of the warranty. The name of the registered owner or class of motor vehicle registration does not by itself determine the purpose or use.

(h) “Days” means calendar days unless otherwise stated.

(i) “Independent automobile expert” means an expert in automotive mechanics who is certified in the pertinent area by the National Institute for Automotive Service Excellence (NIASE). The expert may be a volunteer, or may be paid by the arbitration program or the manufacturer for his or her services, but in all other respects shall be in both fact and appearance independent of the manufacturer.

(j) “Manufacturer” means a new motor vehicle manufacturer, manufacturer branch, distributor or distributor branch, required to be licensed pursuant to Article 1 (commencing with Section 11700) of Chapter 4 of Division 5 of the Vehicle Code, or any other person (including any entity) actually making a written warranty on a new motor vehicle.

(k) “New motor vehicle” means a new motor vehicle which is used or bought for use primarily for personal, family or household purposes. “New motor vehicle” also means a new motor vehicle with a gross vehicle weight under 10,000 pounds that is bought or used primarily for business purposes by a person, including a partnership, limited liability company, corporation, association, or any other legal entity, to which not more than five motor vehicles are registered in this state. The term includes a dealer-owned vehicle, a “demonstrator,” and any other motor vehicle sold or leased with a manufacturer’s new car warranty. The term does not include a motorcycle, or a motor vehicle which is not registered under the Vehicle Code because it is to be operated or used exclusively off the highways. The term “new motor vehicle” also includes the chassis and chassis cab of the motor home, and that portion of a motor home devoted

to its propulsion, but does not include any portion of a motor home designed, used or maintained primarily for human habitation. A “motor home” is a vehicular unit built on, or permanently attached to, a self-propelled motor vehicle chassis, chassis cab or van, which becomes an integral part of the completed vehicle, designed for human habitation for recreational or emergency occupancy. A “demonstrator” is a vehicle assigned by a dealer for the purpose of demonstrating qualities and characteristics common to vehicles of the same or similar model and type.

(l) “Nonconformity” means any defect, malfunction or failure to conform to the written warranty.

(m) “Substantial nonconformity” means any defect, malfunction or failure to conform to the written warranty which substantially impairs the use, value or safety of the new motor vehicle to the consumer.

(n) “Written warranty” means either:

(1) any written affirmation of fact or written promise made by a manufacturer to a consumer in connection with the sale or lease of a new motor vehicle which relates to the nature of the material or workmanship and affirms or promises that such material or workmanship is defect-free or will meet a specified level of performance over a specified period of time;

(2) any undertaking in writing made by a manufacturer to a consumer in connection with the sale or lease of a new motor vehicle to refund, repair, replace, or take other remedial action with respect to the vehicle in the event that the vehicle fails to meet the specifications set forth in the undertaking, which written affirmation, promise or undertaking becomes part of the basis of the bargain.

#### AUTHORITY:

**Note:** Authority cited: Sections 472, et seq., 472.1(b) and 472.4(f), Business and Professions Code. Reference: Sections 1791(a), (b) and (g), 1791.2, 1793.2(a)-(d), 1793.22(b), 1794 and 1795.4, Civil Code; Sections 472(b), 472.1(c) and 472.2(b), Business and Professions Code; 15 USC 2304(a); and 16 CFR Sections 701(d), 703.1(f) and (g).

#### HISTORY:

1. New subchapter 2 (sections 3396.1-3399.6, not consecutive) filed 1-3-90; operative 2-2-90 (Register 90, No. 3). For history of former subchapter 2, see Registers 89, No. 7 and 86, No. 13.
2. Change without regulatory effect adopting new article 1 and amending subsections (a), (c), (e), (f) and Note filed 8-31-94 pursuant to section 100, title 1, California Code of Regulations (Register 94, No. 35).
3. Change without regulatory effect adding new Division 33.1 and deleting Chapter 2 heading filed 3-31-95 pursuant to section 100, title 1, California Code of Regulations (Register 95, No. 13).
4. Change without regulatory effect amending division heading and subsections (e) and (f) filed 1-25-99 pursuant to section 100, title 1, California Code of Regulations (Register 99, No. 5).
5. Editorial correction of subsection (g) (Register 99, No. 13).
6. Change without regulatory effect amending subsection (k) filed 3-26-99 pursuant to section 100, title 1, California Code of Regulations (Register 99, No. 13).
7. Change without regulatory effect amending subsection (k) filed 1-25-2001 pursuant to section 100, title 1, California Code of Regulations (Register 2001, No. 4).

#### § 3397. Scope of Regulations.

#### AUTHORITY:

**Note:** Authority cited: Sections 9889.31(a) and 9889.33, Business and Professions Code. Reference: Sections 9889.30 and 9889.32, Business and Professions Code.

**HISTORY**

1. New Subchapter 3 (Articles 1-3, Sections 3397-3397.43, not consecutive) filed 12-14-83; effective upon filing pursuant to Government Code Section 11346.2(d) (Register 83, No. 51).
2. Repealer filed 8-24-88; operative 9-23-88 (Register 88, No. 37).

**ARTICLE 2.****Minimum Standards for Manufacturers**

- § 3397.1. General Duties.
- § 3397.2. Disclosures by Manufacturer to Consumers.
- § 3397.3. Resolution of Disputes Directly by Manufacturer.
- § 3397.4. Manufacturer's Duty to Aid in Investigation.
- § 3397.5. Manufacturer's Duties Following Decision.

**§ 3397.1. General Duties.**

(a) The manufacturer shall fund and staff the arbitration program at a level sufficient to ensure fair and expeditious resolution of all disputes.

(b) The manufacturer shall take all steps necessary to ensure that the arbitration program, and its arbitrators and staff, are sufficiently insulated from the manufacturer and the sponsor (if other than the manufacturer), so that the decisions of the arbitrators and the performance of the staff are not influenced by either the manufacturer or the sponsor.

(c) The manufacturer shall comply with any reasonable requirements imposed by the arbitration program to fairly and expeditiously resolve warranty disputes, and shall perform all obligations to which it has agreed concerning the handling and resolution of disputes.

(d) The manufacturer shall comply with the provisions of both this part and Article 3 of this subchapter insofar as they impose obligations on the manufacturer.

**AUTHORITY:**

**Note:** Authority cited: Sections 472.1(b) and (c) and 472.4(f), Business and Professions Code. Reference: 16 CFR Sections 703.2(f)(3) and (h), 16 CFR 703.3(a) and (b); Section 1793.22(d)(1), Civil Code; and Sections 472.1(b) and 472.4(f), Business and Professions Code.

**HISTORY**

1. New section filed 1-3-90; operative 2-2-90 (Register 90, No. 3). For prior history, see Register 88, No. 37.
2. Change without regulatory effect amending NOTE filed 8-31-94 pursuant to section 100, title 1, California Code of Regulations (Register 94, No. 35).

**§ 3397.2. Disclosures by Manufacturer to Consumers.**

(a) The manufacturer shall include together, either in its written warranty or in a separate section of materials accompanying each vehicle sold or leased in California, in clear and readily understood language, the following information about the manufacturer's arbitration program and how to use it:

(1) Either

(A) a form addressed to the arbitration program containing spaces requesting the information which the program may require for prompt resolution of warranty disputes, or

(B) a telephone number of the arbitration program which consumers may use without charge.

(2) The name and address of the arbitration program.

(3) A brief description of the arbitration program's procedures and how to use them. The Arbitration Certification Program may reproduce such materials to inform the public about each program.

(4) The time limits adhered to by the arbitration program.

(5) The types of information which the arbitration program may require for prompt resolution of warranty disputes.

(6) If applicable, a clear statement explaining any requirement imposed by the manufacturer that the consumer resort to the arbitration program before invoking rights or remedies conferred by 15 USC Section 2310 or Civil Code Section 1793.22(b), together with a disclosure that the consumer is not required to resort to the program if the consumer chooses to seek redress by pursuing rights and remedies not created by those laws.

(7) Any limits on the scope of the decision, if authorized by Section 3398.10(d).

(8) A statement that if the consumer accepts the decision of the arbitration program, the manufacturer will be bound by the decision, and will comply with the decision within a reasonable time not to exceed 30 days after the manufacturer receives notice of the consumer's acceptance of the decision.

(9) A statement that the consumer may reject the decision and go to court, and that the decision and any findings will be admissible in any court action.

(b) The form described in subdivision (a)(1)(A) of this section may request any information reasonably necessary to decide the dispute including:

(1) The consumer's name, address and telephone number.

(2) The brand name and vehicle identification number (VIN) of the vehicle.

(3) The approximate date of the consumer's acquisition of the vehicle.

(4) The name of the selling dealer or the location where the vehicle was acquired.

(5) The current mileage.

(6) The approximate date and mileage at the time the problem was first brought to the attention of the manufacturer or any of its repair facilities.

(7) A brief statement of the nature of the problem and whether the problem is continuing.

(8) The names if known of any other dealers where the vehicle was serviced.

(9) A statement of the relief that is sought.

**AUTHORITY:**

**Note:** Authority cited: Sections 472.1(b) and 472.4(f), Business and Professions Code. Reference: 16 CFR Sections 703.2(b)(3), 703.2(c)(1)-(5), 703.5(e)(1); Sections 1793.22(c) and 1793.22(d)(1)-(3), Civil Code.

**HISTORY**

1. New section filed 1-3-90; operative 2-2-90 (Register 90, No. 3). For prior history, see Register 88, No. 37.
2. Change without regulatory effect amending subsections (a)(6) and Note filed 8-31-94 pursuant to section 100, title 1, California Code of Regulations (Register 94, No. 35).
3. Change without regulatory effect amending subsection (a)(3) filed 1-25-99 pursuant to section 100, title 1, California Code of Regulations (Register 99, No. 5).

**§ 3397.3. Resolution of Disputes Directly by Manufacturer.**

(a) The manufacturer shall take steps reasonably calculated to make consumers aware of the arbitration program's existence at the time consumers experience warranty disputes.

(b) Nothing contained in this subchapter shall limit the manufacturer's option to encourage consumers to seek redress directly from the manufacturer as long as the manufacturer does not expressly require consumers to seek redress directly from the manufacturer. The manufacturer shall proceed fairly and expeditiously to attempt to resolve all disputes submitted directly to the manufacturer.

(c) Whenever a dispute is submitted directly to the manufacturer, the manufacturer shall, within a reasonable time, decide whether and to what extent it will attempt to satisfy the consumer, and shall inform the consumer of its decision. In its notification to the consumer of its decision, the manufacturer shall include the information specified in subdivision (a) of Section 3397.2.

(d) Disputes settled after the arbitration program has received notification of the dispute shall be subject to Sections 3398.9(b) and 3398.12(b).

**AUTHORITY:**

**Note:** Authority cited: Sections 472.1(b) and 472.4(f), Business and Professions Code. Reference: 16 CFR Sections 703.2(d) and (e), 703.5(d) (4), 703.5(h); and Section 1793.22(d)(1), Civil Code.

**HISTORY**

1. New section filed 1-3-90; operative 2-2-90 (Register 90, No. 3).
2. Change without regulatory effect amending NOTE filed 8-31-94 pursuant to section 100, title 1, California Code of Regulations (Register 94, No. 35).

**§ 3397.4. Manufacturer's Duty to Aid in Investigation.**

(a) The manufacturer shall respond fully and promptly to reasonable requests by the arbitration program for information relating to disputes.

(b) The manufacturer shall fully and promptly respond to reasonable requests by the arbitration program for any pertinent documents in its possession or under its control, such as:

- (1) technical service bulletins;
- (2) recall or parts replacement notices;
- (3) U.S. Department of Transportation publications;
- (4) repair records for a particular vehicle; and
- (5) any other documents which it is reasonable that the manufacturer should provide.

**AUTHORITY:**

**Note:** Authority cited: Sections 472.1(b) and 472.4(f), Business and Professions Code. Reference: 16 CFR Sections 703.2(f)(1), 703.2(h) and 703.5(c); and Section 1793.22(d)(1), Civil Code.

**HISTORY**

1. New section filed 1-3-90; operative 2-2-90 (Register 90, No. 3).
2. Change without regulatory effect amending NOTE filed 8-31-94 pursuant to section 100, title 1, California Code of Regulations (Register 94, No. 35).

**§ 3397.5. Manufacturer's Duties Following Decision.**

(a) The decision shall be binding on the manufacturer if the consumer elects to accept the decision.

(b) The manufacturer shall perform any decision of an arbitration program within the time prescribed by the decision, which shall be a reasonable time not to exceed 30 days after the manufacturer is notified that the consumer has accepted the decision. Delays caused by reasons beyond the control of the manufacturer or its representatives, including any delay directly attributable to any act or omission of the consumer, shall extend the period for performance, but only while the reason for the delay continues.

(c) When the decision of the arbitration program provides that the nonconforming motor vehicle be replaced or that restitution be made to the consumer, and the decision is subject to Civil Code Section 1793.2(d), the manufacturer shall either replace the vehicle if the consumer consents to this remedy or make restitution, and shall do so in accordance with Civil Code Section 1793.2(d)(2)(A), (B) and (C).

(d) The manufacturer shall not attempt to negotiate a settlement with the consumer between the time a decision of an arbitration program is disclosed to the manufacturer and the time the decision is disclosed to the consumer.

**AUTHORITY:**

**Note:** Authority cited: Sections 472.1(b) and 472.4(f), Business and Professions Code. Reference: Section 1793.2(d) and 1793.22(b), Civil Code.

**HISTORY**

1. New section filed 1-3-90; operative 2-2-90 (Register 90, No. 3).
2. Change without regulatory effect amending NOTE filed 8-31-94 pursuant to section 100, title 1, California Code of Regulations (Register 94, No. 35).

# Index

## A

### ABANDONED VEHICLES.

Removal of parked or abandoned vehicles., Veh §22651.07.

### ACTIONS.

#### Collection, actions for.

Proof of license, B&P §143.

#### Consumer affairs department.

Commencement of legal proceedings on behalf of consumers, B&P §321.

#### Consumer complaints.

Actionable complaints, B&P §325.

#### Dealers.

Individual's action against, B&P §9884.18.

#### Public safety officers.

Violation of rights and protections of, Gov §3309.5.

#### Securities and commodities.

Enforcement of provisions, Gov §12658.

### ADDRESS.

#### Change of address.

Notice, B&P §136.

#### Current address of licensees, CCR

§16.3303.3.

**ADMINISTRATIVE LAW**, Gov §§11340 to 11350.3.

**Administrative Register and Code**, Gov §§11344 to 11345.

**Administrative review of regulations**, Gov §§11349 to 11349.6.

Office of Administrative Law, review by, Gov §§11349.1 to 11349.6.

**Adoption, amendment, or repeal of regulations.**

Review procedures, existing regulations, Gov §§11349.7 to 11349.9.

**Definitions**, Gov §§11342.510 to 11342.610.

**Judicial review of regulations**, Gov §§11350 to 11350.3.

#### Regulations of administrative

agencies, Gov §§11342.1 to 11342.4.

Administrative Register and Code, Gov §§11344 to 11345.

Filing and publication procedures, Gov §§11343 to 11343.8.

### ADVERTISING.

**Broadcasters, exemptions**, B&P §17502.

#### Buses.

Santa Monica.  
Illuminated advertising signs, Veh §25353.1.

#### Criminal penalties.

Gifts, unlawful use of in advertising, B&P §17537.

#### Emissions inspections.

Smog check stations.  
Licensing of stations and technicians.  
Certification, voluntary, H&S §44014.4.

**Fact-based or brand-comparison advertising**, B&P §17508.

**False advertising**, B&P §§17500 to 17509, CCR §§16.3370 to 16.3377.

Applicability of regulations, CCR §16.3370.

### ADVERTISING —Cont'd

#### False advertising —Cont'd

Attorney general.

Notice to attorney general of appellate proceedings, B&P §17536.5.

Board within department of consumer affairs.

Defined, B&P §17506.5.

Brand comparison advertisements, B&P §17508.

Dealers.

Guarantees, CCR §§16.3375, 16.3376.

Pro rata guarantees, CCR §16.3377.

Identification of advertiser, CCR §16.3371.

Parts.

Misrepresentations as to new, used, reconditioned, etc., parts, CCR §16.3374.

Presumptions, CCR §16.3371.1.

Price advertising, CCR §16.3372.1.

Records.

False recordkeeping, CCR §16.3373.

Warranties, CCR §§16.3375, 16.3376.

Pro rata guarantees, CCR §16.3377.

Definition of false and misleading, CCR §16.3372.

Energy conservation services, B&P §17537.5.

Fact-based advertising.

Purportedly fact-based advertising, B&P §17508.

Gifts.

Inducement to visit or to attend sales pitch.

Disclosures, B&P §17537.1.

Unfair trade practices, what

constitutes, B&P §17537.2.

Governmental emblems, use of, B&P §17533.6.

Identification of advertiser, CCR §16.3371.

Injunctions, B&P §17535.

Violation of injunction, B&P §17535.5.

Local consumer affairs agency.

Defined, B&P §17506.5.

Odds of receiving incentive, disclosure of, B&P §17537.1.

Person.

Defined, B&P §17506.

Price differentials of articles within same class, B&P §17507.

Prizes.

Inducement to visit or to attend sales pitch.

Disclosures, B&P §17537.1.

Unfair trade practices, what

constitutes, B&P §17537.2.

Purchase conditioned on purchase of

different product, B&P §17509.

Remedies.

Cumulative nature of remedies, B&P §17534.5.

Statements.

False or misleading statements, B&P §17500.

Untrue or misleading advertising, CCR §16.3371.

Violations, B&P §17534.

Fines for violating chapter, B&P §17536.

### ADVERTISING —Cont'd

**Former price, advertising**, B&P §17501.

#### Gifts, use of.

Civil action for violations, B&P §17537.4.

#### Imported goods.

Made in U.S.A., improper use, B&P §17533.7.

**Internet, false or misleading ads**, B&P §17537.5.

#### License numbers.

Inclusion in advertising.

Regulations, B&P §137.

**Misrepresenting nature of business**, B&P §17505.

Recreation therapists, B&P §17505.2.

**Person, defined**, B&P §17506.

**Price differentials regarding more than one item within same class**, B&P §17507.

**Prices of goods sold in multiple units**, B&P §17504.

**Prohibiting advertising not in violation of law.**

Rules not to be enacted, B&P §17500.1.

**Quantity of item to be sold to single customer**, B&P §17500.5.

**Solicitation of sales at residence or by telephone**, B&P §17500.3.

#### Unlicensed activity enforcement.

Telephone directory advertising.

Notice to cease, B&P §149.

**Value determinations**, B&P §17501.

### AGED PERSONS.

#### Unfair competition.

Senior citizen as victim.

Fines, B&P §17206.1.

### AIR BAGS.

**Installation standards**, CCR §16.3367.

**Previously deployed air bags**, Veh §27317.

**Supplemental restraint system, defined**, Veh §593.

### AIR CONDITIONING REPAIR.

**Equipment requirements**, CCR §16.3351.6.

**Trade standards for repairs**, CCR §16.3366.

### AIR POLLUTION.

**Accelerated retirement of light-duty vehicles**, H&S §§44100 to 44122.

Avoidance vehicles, H&S §§44106, 44107.

Contents of program, H&S §44101.

Convenience of purchase transactions, H&S §44115.

Coordination of program requirements with inspection program, H&S §44102.

Disposal of vehicles, H&S §44120.

Emission reduction credits.

Certification, H&S §44121.

Funding, H&S §44104.

Initial 2 year plan, H&S §44104.5.

Legislative intent, H&S §44100.

Objectives of program, H&S §44103.

Oversight agency, H&S §44105.

Quantifying emissions reductions, H&S §44122.

Reporting of progress, H&S §44104.5.

**AIR POLLUTION —Cont'd****Accelerated retirement of light-duty vehicles —Cont'd**

Soliciting owners of vehicles, H&S §44109.

Tampering and fraud.

Discouraging, H&S §44107.

Inclusion of provisions in program, H&S §44106.

**Bay area air quality management district.**

Board members, H&S §40221.5.

**Carbon monoxide.**

Gross polluters, H&S §39032.5.

**Carl Moyer memorial air quality standards attainment program,**

H&S §§44275 to 44299.2.

Administration of money in fund, H&S §44299.1.

Administration of program, H&S §44280.

Allocations to local air pollution and air quality management districts, H&S §44299.2.

Creation of program, H&S §44280.

Criteria for projects, H&S §44282.

Cost-effectiveness criteria, H&S §44283.

Definitions, H&S §44275.

Eligible projects, H&S §44281.

Grant criteria and guidelines, H&S §44287.

Purpose of program, H&S §44280.

Reservation of funds, H&S §44287.

Segregation of money in fund, H&S §44299.1.

**Clean air act implementation fees,**

H&S §§44225, 44229.

**Control districts.**

Sacramento metropolitan air quality management district.

Surcharge on vehicle registration fees, H&S §41081.

**Definitions,**

H&S §§39010 to 39060.

Gross polluter, H&S §39032.5.

**Designated air pollution control agency,**

H&S §39602.

**Emissions control label, Rev&Tax §6263.****Emissions inspections.**

Generally, H&S §§44000 to 44122.

See EMISSIONS INSPECTIONS.

Gross polluters, H&S §§44080 to 44086.

See EMISSIONS INSPECTIONS.

High polluters, H&S §§44090 to 44096.

See EMISSIONS INSPECTIONS.

**Exhaust emissions devices, older cars.**

Auctioneer responsibilities when selling older cars, Veh §24007.5.

Elderly low-income purchaser of older cars.

Free installation of exhaust devices,

Veh §24007.2.

**Exhaust systems generally.**

Disconnecting, modifying, etc., Veh §42001.14.

Equipment of vehicles, Veh §§27156, 27159.

**Fees to implement clean air act,**

H&S §§44225, 44229.

**Gross polluter,**

H&S §39032.5.  
Emissions inspections, H&S §§44080 to 44086.

See EMISSIONS INSPECTIONS.

Exhaust equipment generally, Veh §§27156, 27159.

**High polluters.**

Emissions inspections, H&S §§44090 to 44096.

See EMISSIONS INSPECTIONS.

**AIR POLLUTION —Cont'd****Light-duty vehicles.**

Accelerated retirement of light-duty vehicles, H&S §§44100 to 44122.

**Methanol-gasoline experimental vehicles,**

H&S §43843.

**Retirement of vehicles.**

Accelerated retirement of light-duty vehicles, H&S §§44100 to 44122.

**Sacramento metropolitan air quality management district.**

Surcharge on vehicle registration fees, H&S §41081.

**Smog impact fee.**

Emission control label, Rev&Tax §6263.

Refunds, Rev&Tax §6909.

Interest, exclusion from gross income, Rev&Tax §17139.5.

**State board as designated air pollution control agency,**

H&S §39602.

**Tampering.**

Accelerated retirement of light-duty vehicles, H&S §§44106, 44107.

**Vehicular air pollution control.**

Accelerated retirement of light-duty vehicles, H&S §§44100 to 44122.

Certificates of compliance.

Direct import used vehicles, H&S §39024.6.

Transfer certificates, Veh §4000.1.

Emissions inspections generally.

See EMISSIONS INSPECTIONS.

Enhanced Fleet Modernization Program, H&S §§44125, 44126.

Exhaust emissions devices, older cars.  
Elderly low-income purchaser of older cars.

Free installation of exhaust devices, Veh §24007.2.

Exhaust systems.

Motorcycles, Veh §27202.1.

Inspections.

Civil penalties, H&S §43012.

Disclosure, H&S §43012.

Generally, H&S §§44000 to 44122.

See EMISSIONS INSPECTIONS.

Notice to correct, H&S §43012.

Right of entry, H&S §43012.

Legislative findings, H&S §44001.1.  
Low emission vehicles, H&S §§43800 to 43804.

Motorized scooters.

Exhaust system modification or alteration.

Manufacturers' notice, Veh §385.5.

Motor vehicle emission standards adoption, H&S §43013.

New motor vehicles.

Prohibited transactions, H&S §§43150 to 43156.

Warranties as to air pollution, H&S §43204.

Light and medium duty vehicles, H&S §43205.

Non-light and medium duty vehicles, H&S §43205.5.

Regulations regarding manufacturer requirements, H&S §43105.5.

Retrofit devices, H&S §39027.5.

Test procedures, H&S §43104.

Used vehicles.

Heavy-duty vehicles.

Legislative intent, H&S §43700.

Regulations, H&S §43701.

Vehicle emission pollution regulations, Veh §27157.

**ALCOHOL-FUELED VEHICLES.****Methanol-gasoline experimental vehicles,**

H&S §43843.

**ALTERED LICENSES.**

Possession or display, B&P §119.

**ALTERNATIVE DISPUTE RESOLUTION.**

Arbitration certification program, CCR §§16.3396.1 to 3397.5.

See ARBITRATION CERTIFICATION PROGRAM.

**New motor vehicle warranties.**

Certification, B&P §§472 to 472.5.

Requirements for dispute resolution generally, CC §1793.22.

**AMERICANS WITH DISABILITIES ACT.**

Rulemaking in conformity to, B&P §313.2.

**ANIMAL CONTROL ENFORCEMENT VEHICLES.****Equipment for vehicles.**

Flashing or warning lights, Veh §25271.5.

**ARBITRATION.**

Certification program, CCR §§16.3396.1 to 3397.5.

See ARBITRATION CERTIFICATION PROGRAM.

**New motor vehicle warranties.**

Certification, B&P §§472 to 472.5.

Requirements for dispute resolution generally, CC §1793.22.

**ARBITRATION CERTIFICATION PROGRAM,**

CCR §§16.3396.1 to 3397.5.

**Applicable law.**

Defined, CCR §16.3396.1.

**Applicant.**

Defined, CCR §16.3396.1.

**Arbitration program.**

Defined, CCR §16.3396.1.

**Arbitrators.**

Defined, CCR §16.3396.1.

**Certification of programs.**

Definition of certification, CCR §16.3396.1.

**Consumers.**

Defined, CCR §16.3396.1.

**Days.**

Defined, CCR §16.3396.1.

**Definitions,**

CCR §16.3396.1.

**Demonstrators.**

Defined, CCR §16.3396.1.

**Independent automobile expert.**

Defined, CCR §16.3396.1.

**Investigations.**

Manufacturer aiding in investigations, CCR §16.3397.4.

Decision.  
Implementation by manufacturer, CCR §16.3397.5.

Direct resolution of disputes, CCR §16.3397.3.

Disclosures by manufacturer, CCR §16.3397.2.

Duties as to program, CCR §16.3397.1.

Investigations.

Aiding in investigations, CCR §16.3397.4.

**Manufacturers.**

Defined, CCR §16.3396.1.

**New motor vehicle.**

Defined, CCR §16.3396.1.

**Nonconformity.**

Defined, CCR §16.3396.1.

**Substantial nonconformity.**

Defined, CCR §16.3396.1.



**ARBITRATION CERTIFICATION PROGRAM**—Cont'd

**Written warranty.**  
Defined, CCR §16.3396.1.

**ARMORED CARS.**

**Equipment for vehicles.**  
Flashing or warning lights,  
Red lights, Veh §25262.

**ARRESTS.**

**License applicants.**  
Prohibitions on asking to reveal arrest records, B&P §461.

**ATTORNEY GENERAL.**

**Advertising.**  
False advertising.  
Notice to attorney general of appellate proceedings, B&P §17536.5.

**Securities and commodities.**

Enforcement of provisions, Gov §12658.  
Investigations, Gov §12659.  
Powers of enforcement under federal laws, Gov §12661.

**State departments and agencies.**

Investigations.  
Assistance at request of attorney general, Gov §11180.5.

**Unfair competition.**

Civil penalty, collection, B&P §17206.  
Injunctions, B&P §17204.  
Notice of appellate proceedings to attorney general, B&P §17209.

**AUTOMOBILE INSURANCE.**

**Good driver discount policy.**  
Rates and qualifications to purchase, Ins §1861.02.

**Vehicle protection products,** Ins §116.6.

**AUTOMOBILE SALES FINANCE.**

**Sales or use tax refunded to buyer or lessee of new motor vehicle under warranty, manufacturer's reimbursement for,** CC §1793.25.

**AUTOMOTIVE PARTS SALES,** Veh §§12000 to 12003.

**Bureau of automotive repair.**

Enforcement of provisions, Veh §12000.

**Defective parts,** Veh §12002.

**Invoices.**

Contents, Veh §12001.

**Misdemeanors for violations,** Veh §12003.

**AUTOMOTIVE PRODUCTS.**

**Engine coolant and antifreeze standards.**

Addition of agent to make unpalatable, B&P §17582.

**AUTOMOTIVE REPAIR ACT,** B&P §9880.

**AUTOMOTIVE REPAIR DEALERS.**

**Generally,** B&P §§9880 to 9889.68.  
See DEALERS.

**AUTOMOTIVE REPAIR FUND.**

**Abolition and transfer of proceeds into vehicle inspection and repair fund,** H&S §44062.

**B****BACKGROUND CHECKS.**

**Fingerprints to be provided in order to conduct,** B&P §144.

**BAIT AND SWITCH.**

**Advertising quantity of item to be sold to single customer,** B&P §17500.5.

**BIBLIOGRAPHY OF CONSUMER INFORMATION.**

**Publication,** B&P §313.5.

**BOARDS.**

**Compensation of members,** B&P §103.  
**Defined,** B&P §22.

**Meetings, regular and special,** B&P §101.7.

**Public members,** B&P §§450 to 452.

Age, B&P §450.6.  
Conflicts of interest, B&P §§450.2, 450.3.  
Prior business, professional, etc., pursuits, B&P §450.5.  
Definition of board, B&P §452.

Delegation of duties to public member, B&P §451.

Qualifications, B&P §450.

**Purposes and functions of boards,** B&P §101.6.

**BODY REPAIR.****Auto body repair shop.**

Defined, B&P §9889.51.

**Checks to shop.**

Auto insurer checks.  
Registration or identification number on check, B&P §9889.68.

Collision insurer checks.

Registration or identification number on check, B&P §9889.53.

**Consumer bill of rights for auto body repair.**

Fair claims settlement practices, insurance, CCR §10.2695.85.

**Equipment.**

Requirements, CCR §16.3351.5.

**Insurance claims handling.**

Inspection of vehicles, Ins §1874.85.  
Bill of rights for insured, Ins §1874.87.  
Reports, Ins §1874.86.  
Requiring repairs at specific dealers, Ins §758.5.

**Legislative intent,** B&P §9889.50.

**Registration.**

Application, B&P §9889.52.

Form.

Information to be contained, B&P §9889.66.

Number.

Inclusion on check issued from auto insurer, B&P §9889.68.

Inclusion on check issued from collision insurer, B&P §9889.53.

**Trade standards for repairs.**

Frame and body repairs, CCR §16.3365.

**BRAKES.****Adjusting stations.**

Lamp and brake adjusting stations, B&P §§9887.1 to 9889.19.

See LAMP AND BRAKE ADJUSTING STATIONS.

**Copper,** H&S §§25250.50 to 25250.65.

**Equipment for vehicles,** Veh §§26301 to 26522.

See EQUIPMENT FOR VEHICLES.

**Friction material reduction,** H&S

§§25250.50 to 25250.55.

Applicability of law, H&S §25250.55.

Concentration limits, H&S §25250.51.

Copper, H&S §§25250.52, 25250.53.

Extension of deadlines, H&S §25250.54.

Definitions, H&S §25250.50.

Exemptions, H&S §25250.55.

Fines and civil penalties, H&S §25250.62.

Reports, H&S §25250.65.

Testing, H&S §25250.60.

Water pollution fund, H&S §25250.64.

**BRAND-COMPARISON ADVERTISING,** B&P §17508.

**BUCKET TRUCKS.**

**Equipment for vehicles.**  
Flashing or warning lights, Veh §25260.3.

**BUREAU OF AUTOMOTIVE REPAIR.**

**Address of licensees.**  
Current address required, CCR §16.3303.3.

**Automotive parts sales.**

Enforcement of provisions, Veh §12000.

**Chief,** B&P §9882.2.

**Dealers.**

Administration of department, B&P §9882.

Notice to public concerning contact with bureau.

Signs in dealerships, B&P §9884.17.  
Regulations, B&P §9884.19.

**Definitions,** CCR §16.3303.

**Emissions inspections.**  
Responsibilities under chapter, H&S §44001.5.

**Licenses.**

Applications.  
Review, CCR §16.3303.2.

**Office.**

Location, CCR §16.3300.

**Public access to information,** CCR §16.3303.1.

**BURGLAR ALARMS.**

**Installation by automobile dealer or manufacturer,** B&P §9806.

**BUSES.****Equipment for vehicles.**

Flashing or warning lights.  
Crime alarm lights, Veh §25275.5.  
Illuminated signs on public transit buses, Veh §25353.  
Traffic signal changing devices, Veh §25352.

**Illuminated signs.**

Santa Monica.  
Illuminated advertising signs, Veh §25353.1.

**Reflectors,** Veh §24608.

**C****CABLE TELEVISION VEHICLES.****Equipment for vehicles.**

Flashing or warning lights, Veh §25274.

**CARL MOYER MEMORIAL AIR****QUALITY STANDARDS ATTAINMENT PROGRAM,** H&S

§§44275 to 44299.2.

See AIR POLLUTION.

**CHEATING.****License examinations.**

Subversion of examination, B&P §123.

**CHERRY PICKERS.****Equipment for vehicles.**

Flashing or warning lights, Veh §25260.3.

**CHILD SUPPORT.****Enforcement.**

Business and occupational licensing restrictions, B&P §31.

**Licenses.**

Child support enforcement.

Suspension of license, Fam §17520.

Withholding issuance or renewal of licenses, Fam §17520.

Suspension or revocation.

Failure to meet obligation, B&P §490.5.

**CHILD SUPPORT** —Cont'd

**Professional license of obligor, denial or nonrenewal**, B&P §31.

**Qualifications for licensure**, B&P §29.5.

**Suspension of license.**

Child support enforcement, Fam §17520.

**CITATIONS.****Emissions inspections.**

Authority to issue, H&S §44050.

Fines and citations generally, CCR 16.3394.25 to 16.3394.27.

Fine schedule, H&S §44051.

Failure to pay, H&S §44055.

Separate violations, H&S §44052.

Violations outside of schedule, H&S §44056.

Smog check stations.

Data from equipment as evidence to appeal citation, H&S §44036.8.

**Regulations.**

Violation of regulation, B&P §12.5.

**System for issuance.**

Boards, etc., may set up system, B&P §125.9.

**Unlicensed activity enforcement.**

Administrative citation system.

Authorized for unlicensed persons, B&P §148.

**CIVIL PENALTIES.****Fines generally.**

See FINES.

**CLEAN AIR.****Air pollution.**

See AIR POLLUTION.

**Emissions inspections.**

See EMISSIONS INSPECTIONS.

**COLLECTOR MOTOR VEHICLES.**

**Defined**, Veh §259.

**Lighting equipment on historical vehicles.**

Exemptions, Veh §25804.

**COMMERCIAL CODE.****Warranties.**

Conflict of laws, CC §1790.3.

**COMMERCIAL VEHICLES.**

**Definitions**, Veh §§260, 288, 289.

**COMMISSIONS.**

**Compensation of members**, B&P §103.

**COMMITTEES.**

**Compensation of members**, B&P §103.

**COMPLAINTS AGAINST LICENSEES.**

**Board, etc., handling**, B&P §129.

**Consumer complaints**, B&P §§325, 326.

**Dealers.**

Procedure for handling, B&P §9882.5.

**Public access to information**, CCR §16.3303.1.

**COMPUTER CRIMES**, Pen §502.**CONFLICT OF LAWS.**

**Emissions inspections**, Veh §24007.6.

Chapter supersedes other emissions inspections programs, H&S §44004.

**Noise inspections**, Veh §24007.6.

**Warranties.**

Commercial code, CC §1790.3.

**CONFLICTS OF INTEREST.****Boards.**

Public members, B&P §§450.2, 450.3.

Prior business, professional, etc., pursuits, B&P §450.5.

**CONSPIRACY.****Licensees.**

Conspiring to violate provisions, B&P §125.

**CONSTRUCTION VEHICLES.**

**Equipment**, Veh §27000.

Flashing or warning lights, Veh §25282.

**CONSUMER AFFAIRS DEPARTMENT.****Accounting.**

Funds of department, B&P §200.

**Boards.**

Generally.

See BOARDS.

**Bureau of automotive repair.**

See BUREAU OF AUTOMOTIVE REPAIR.

**Citation of chapter**, B&P §300.

**Commissions.**

Compensation of members, B&P §103.

**Committees.**

Compensation of members, B&P §103.

**Conferences.**

Officers and employees of department or boards, B&P §113.

**Constituent boards**, B&P §§100, 101.

Action by board against state or federal government, permission to bring, B&P §132.

As separate units, B&P §108.

Executive officers of boards, B&P §107.

Oaths.

Members, B&P §105.

Removal of members, B&P §§106, 106.5.

Reports, B&P §§126, 127.

Review of licensing decisions, B&P §109.

Seals.

Requirements, B&P §107.5.

Terms of members, B&P §105.5.

**Consumer contracts.**

Settlement provisions in agreements.

Prohibited provisions, B&P §143.5.

**Definitions**, B&P §302.

**Director.**

Actions.

Commencement of legal proceedings on behalf of consumers, B&P §321.

Administration of provisions, B&P §305.

Bibliography of consumer information.

Publication, B&P §313.5.

Consultants, B&P §307.

Consumer complaints, B&P §§325, 326.

Defined, B&P §302.

Duties, B&P §310.

Experts, B&P §307.

Interdepartmental committee, B&P §311.

Intervention on behalf of consumers, B&P §320.

Library, B&P §313.

Powers, B&P §310.

Reports to governor and legislature, B&P §312.

Rulemaking.

Americans with disabilities act.

Conformity to, B&P §313.2.

Procedure, B&P §313.1.

Staff, B&P §306.

**Directories of licensees**, B&P §112.

**Division of consumer services.**

Established, B&P §303.

**Emissions inspections.**

Powers of department, H&S §44002.

**Examinations.**

Investigations into alleged misconduct, B&P §109.

**Initiatives.**

Assumption of duties of board for professions regulated by initiatives, B&P §102.

**Interagency agreements**, B&P §102.3.

**Internet.**

Providing information via internet, B&P §27.

**Legislative intent**, B&P §301.

**CONSUMER AFFAIRS DEPARTMENT**

—Cont'd

**Licensees of department.**

Local government taxation or restrictions, B&P §460.

**Licensees.**

Unlawful use of, B&P §119.

**Public access to information**, CCR §16.3303.1.

Information to be provided on Internet, B&P §27.

**Public members of boards.**

Qualifications, B&P §450.

**Purpose of department**, B&P §101.6.

**Records**, B&P §110.

**Refunds**, B&P §200.

**Reports from boards, etc.**, B&P §127.

**Unlicensed activity.**

Enforcement of provisions, B&P §§145 to 149.

**Witness fees**, B&P §108.5.

**CONSUMER COMPLAINTS.**

**Actionable complaints**, B&P §325.

**Proceedings**, B&P §326.

**CONSUMER REPRESENTATION.****Actions.**

Commencement of legal actions, B&P §321.

**Intervention in proceedings**, B&P §320.

**CONSUMER WARRANTIES.**

**Warranties generally**, CC §§1790 to 1795.

See WARRANTIES.

**CONTEMPT.****State departments and agencies.**

Investigations.

Contempt for failure to appear, Gov §11188.

**CONTRACTORS.****Equipment for vehicles.**

Flashing or warning lights.

Contractor vehicles, Veh §25282.

**CONVICTIONS.**

**Actions which may be taken by boards following convictions.**

Time for taking, B&P §7.5.

**Defined**, B&P §7.5.

**Emissions inspections.**

Licensees.

Discipline, H&S §44072.3.

**Licensees.**

Denial for conviction of crime, B&P §480.

Criteria for rehabilitation, CCR §16.3395.

**CORONER VEHICLES.****Equipment for vehicles.**

Flashing or warning lights, Veh §25264.

**COUNTERFEITING.****Licensees.**

Buying or receiving counterfeit license, B&P §119.

**Registration of vehicles.**

False, altered, etc., registration, title, etc., Veh §4463.

**CRIMINAL INTENT.**

**Unity of act and intent**, Pen §20.

**CRIMINAL RECORDS CHECKS.**

**Fingerprints to be provided in order to conduct**, B&P §144.

**D****DAMAGES.**

**Computer crimes**, Pen §502.

**DAMAGES** —Cont'd**Licenses.**

- Examinations.
- Subversion of examination, B&P §123.

**Warranties.**

- Sales warranties.
- Buyers, CC §1794.
- Seller's damages, CC §1794.1.
- Service provider's damages, CC §1794.1.

**DEALERS**, B&P §§9880 to 9889.68.**Advertisements**, B&P §17537.7.**Advertising.**

- False advertising.
- See ADVERTISING.

**Air conditioning repair.**

- Equipment requirements, CCR §16.3351.6.
- Trade standards for repairs, CCR §16.3366.

**Automatic transmissions.**

- Trade standards for repairs, CCR §16.3361.1.

**Automotive repair act.**

- Citation of provisions, B&P §9880.

**Automotive repair dealer.**

- Defined, B&P §9880.1.

**Automotive technician.**

- Defined, B&P §9880.1.

**Ball joints.**

- Trade standards for repairs, CCR §§16.3360.1, 16.3360.2.
- Recommendations, CCR §16.3360.3.

**Body repair.**

- Generally.
- See BODY REPAIR.

**Bureau.**

- Administration of provisions, B&P §9882.
- Chief, B&P §9882.2.
- Defined, B&P §9880.1.
- Established, B&P §9882.
- Notice to public concerning contact with bureau.
- Signs in dealerships, B&P §9884.17.
- Protection of public as highest priority for bureau, B&P §9880.3.
- Regulations, B&P §9884.19.

**Burglar alarms or electronic sets.**

- Installation by dealer, B&P §9806.

**Charges to enforce chapter**, B&P §9884.15.**Chief.**

- Defined, B&P §9880.1.

**Commercial business agreement.**

- Defined, B&P §9880.1.

**Complaint procedure**, B&P §9882.5.

- Time for filing, B&P §9884.20.

**Consent of customers for work**, B&P §9884.9.**Dealer's cost, references to**, B&P §17537.7.**Definitions**, B&P §9880.1, Veh §§286, 426.**Director.**

- Complaint procedure, B&P §9882.5.
- Defined, B&P §9880.1.
- Delegation, B&P §9882.3.
- Deny, suspend or revoke registration, B&P §9884.7.
- Duties, B&P §9884.2.
- Investigation of violations, B&P §9882.5.
- Issue registration, B&P §9884.2.
- Record of registered dealers, B&P §9882.4.
- Staffing, B&P §9882.1.

**Disciplinary action.**

- Forms of discipline, B&P §9884.22.

**Disclosure requirements**, CCR

- §§16.3352 to 3359.
- Definitions, CCR §16.3352.

**DEALERS** —Cont'd**Disclosure requirements** —Cont'd

- Guarantees, CCR §16.3376.
- Invoices.
- Defined, CCR §16.3352.
- Requirements, CCR §16.3356.
- Recordkeeping, CCR §16.3358.
- Replaced parts.
- Nonreturnable parts, CCR §16.3355.
- Sublets, CCR §16.3359.
- Toxic waste disposal costs, CCR §16.3356.1.
- Warranties, CCR §16.3376.
- Work orders.
- Defined, CCR §16.3352.
- Written estimates.
- Defined, CCR §16.3352.
- Effect, CCR §16.3353.
- Requirements, CCR §16.3353.

**Emissions inspections.**

- Right of entry for inspection, H&S §43012.

**Engines.**

- Trade standards for repairs, CCR §16.3362.1.

**Equipment.**

- Air conditioning repair.
- Requirements, CCR §16.3351.6.
- Body shops.
- Requirements, CCR §16.3351.5.

**Estimates.**

- Written estimates, B&P §9884.9.

**Exclusions from dealer status**, Veh §286.**Filing charges with district or city attorney**, B&P §9884.15.**Gold shield program (GSP)**, CCR §16.3392.1 to 16.3392.6.

- See GOLD SHIELD PROGRAM (GSP).

**Guarantees.**

- Disclosure requirements, CCR §16.3376.
- False advertising, CCR §16.3375.
- Gold shield program (GSP), CCR §16.3392.1 to 16.3392.6.
- See GOLD SHIELD PROGRAM (GSP).
- Pro rata guarantees, CCR §16.3377.

**Ignition interlock devices.**

- Installation standards, B&P §9882.14.
- Trade standards for repairs, CCR §16.3363.1.
- Authorized installers, CCR §16.3363.3.
- Installation standards, CCR §16.3363.4.
- Manufacturer duties as to, CCR §16.3363.2.

**Insurance claims handling.**

- Direct repair program.
- Requiring shop to pay for rental vehicle, Ins §758.
- Inducement by dealers of insurers to direct business to dealer, Pen §551.

**Investigation of violations**, B&P §9882.5.**Invoice price references**, B&P §17537.7.**Invoices.**

- Defined, CCR §16.3352.
- Recording work done on invoice, B&P §9884.8.
- Requirements, CCR §16.3356.

**Lamp and brake adjusting stations**, B&P §§9887.1 to 9889.19.

- See LAMP AND BRAKE ADJUSTING STATIONS.

**Liens.**

- Registration.
- Prerequisite to filing of lien, B&P §9884.16.

**Motor vehicles.**

- Defined, B&P §9880.1.

**DEALERS** —Cont'd**Notice to public concerning contact with bureau.**

- Signs in dealerships, B&P §9884.17.

**Perjury**, B&P §9889.22.

- Criminal provisions, Pen §§118, 126.

**Subornation of perjury**, Pen §127.**Person.**

- Defined, B&P §9880.1.

**Probationary registration**, B&P §9884.21.**Protection of public as highest priority for bureau**, B&P §9880.3.**Recordkeeping**, B&P §9884.11.

- Disclosure requirements, CCR §16.3358.
- False records, CCR §16.3373.

**Registration.**

- Actions against dealers.
- Individual actions, B&P §9884.18.
- Application.
- Filing, CCR §16.3351.
- Multiple facilities, B&P §9884.1.
- Charges to enforce chapter, B&P §9884.15.
- Display, CCR §16.3351.3.
- Estimates.
- Written estimates, B&P §9884.9.
- Exemptions from requirements, B&P §9880.2.
- Expired registrations, B&P §9884.5.
- Jurisdiction of disciplinary proceedings, B&P §9884.13.
- Fees, CCR §16.3351.1.
- Payment for each place of business, B&P §§9884, 9884.1.
- Renewal.
- Termination of registration for nonpayment, B&P §9884.3.
- Schedule, B&P §9886.3.
- Forms, B&P §9884.
- Information not current.
- Termination of registration, B&P §9884.4.
- Injunctions of violations, B&P §9884.14.
- Invalidation.
- Grounds, B&P §9884.7.
- Rehabilitation, CCR §16.3395.1.
- Invoices.
- Recording work done on invoice, B&P §9884.8.
- Liens.
- Prerequisite of registration to filing of lien, B&P §9884.16.
- Notice to public concerning contact with bureau.
- Signs in dealerships, B&P §9884.17.
- Procedure.
- Applicable provisions, B&P §9884.12.
- Generally, B&P §§9884 to 9884.22.
- Recordkeeping, B&P §9884.11.
- Record of registered dealers, B&P §9882.4.
- Regulations.
- Bureau's regulations, B&P §9884.19.
- Renewal.
- Failure to renew.
- Termination of registration, B&P §9884.5.
- Fees, B&P §9884.3.
- Timing, CCR §16.3351.2.
- Replaced parts.
- Return to customer, B&P §9884.10.
- Required, B&P §9884.6.
- Suspension, revocation or denial.
- Administrative procedure, CCR §16.3395.4.
- Criteria, relation of acts to fitness to perform under registration, CCR §16.3395.2.

**DEALERS** —Cont'd**Registration** —Cont'd

Validation, B&P §9884.2.  
Refusal.

Grounds, B&P §9884.7.

Rehabilitation, CCR §16.3395.1.

**Repair of motor vehicles.**

Defined, B&P §9880.1.

**Replaced parts.**

Nonreturnable parts, CCR §16.3355.

Return to customer, B&P §9884.10.

**Scope of chapter, B&P §9880.****Signs.**

Display, CCR §16.3351.3.

Specifications, CCR §16.3351.4.

**Sublets.**

Disclosure requirements, CCR §16.3359.

**Toxic waste disposal costs, CCR**

§16.3356.1.

**Trade standards for repairs, CCR**

§§16.3360 to 16.3366.

Scope, CCR §16.3360.

**Vehicle and inspection repair fund.**

Availability of funds, B&P §9886.2.

Created, B&P §9886.

Disposition of revenue collected, B&P §9886.

Fee schedule, B&P §9886.3.

Payments from fund, B&P §9886.4.

Reports, B&P §9886.1.

**Vehicle identification numbers.**

Trade standards for repairs.

Restrictions on things done to VIN,  
CCR §16.3364.

**VIN.**

Trade standards for repairs.

Restrictions on things done to vehicle  
identification number, CCR  
§16.3364.

**Violations, B&P §9889.20.**

Filing charges with district or city  
attorney, B&P §9884.15.

**Warranties.**

Disclosure requirements, CCR §16.3376.

False advertising, CCR §16.3375.

Gold shield program (GSP), CCR

§§16.3392.1 to 16.3392.6.

See GOLD SHIELD PROGRAM (GSP).

Pro rata guarantees, CCR §16.3377.

**Work orders.**

Defined, CCR §16.3352.

**Written estimates.**

Defined, CCR §16.3352.

Effect, CCR §16.3353.

Requirements, CCR §16.3353.

**DECCELERATION WARNING LIGHTS,**

Veh §25251.5.

**Mounting requirements, CCR §13.690.****Operating requirements, CCR §13.731.****Scope of regulation, CCR §13.730.****DEFINED TERMS.****Acceleration simulation mode (ASM).**

Emissions inspections, CCR §16.3340.1.

**Access, computers, Pen §502.****Account.**

Emissions inspections, high polluters  
repair or removal, H&S §44090.

**Act.**

Bureau of automotive repair, CCR  
§16.3303.

**Administrator.**

Service contracts, Ins §12800.

**Advisory board.**

Carl Moyer memorial air quality  
standards attainment program, H&S  
§44275.

**Advisory committee.**

Motor vehicle brake friction material  
reduction, H&S §25250.50.

**DEFINED TERMS** —Cont'd**Aftermarket lighting device.**

Lighting equipment regulation, CCR  
§13.623.

**After repairs test.**

Emissions inspections, CCR §16.3340.1.

**Agency.**

Administrative law, Gov §11342.520.

**Agricultural source of air pollution,**

H&S §39011.5.

**Airbrakes, Veh §108.****Alternative fuel retrofit system.**

Emissions inspections, CCR §16.3340.1.

**Applicable law.**

Arbitration certification program, CCR  
§16.3396.1.

**Applicant.**

Arbitration certification program, CCR  
§16.3396.1.

Child support enforcement, Fam §17520.

Discrimination, B&P §125.6.

**Application.**

License denial, suspension or revocation,  
B&P §478.

**Arbitration certification program, CCR**

§16.3396.1.

**Arbitration program.**

Arbitration certification program, CCR  
§16.3396.1.

**Arbitrator.**

Arbitration certification program, CCR  
§16.3396.1.

**ARD-exempt heavy-duty station.**

Emissions inspections, CCR §16.3340.1.

**Area reflectorizing material.**

Equipment, reflex reflectors on front of  
vehicle, CCR §13.761.

**As is.**

Warranties, CC §1791.3.

**ASM.**

Emissions inspections, CCR §16.3340.1.

**Assistive device.**

Warranties, CC §1791.

**Authorization.**

Bureau of automotive repair, CCR  
§16.3303.

**Authorized emergency vehicle, Veh**

§165.

Privately owned, Veh §165.

**Auto body repair shop, B&P §9889.51.**

Bureau of automotive repair, CCR  
§16.3303.

**Automobile dismantler, Veh §§220, 221.****Automobile dismantler's tow vehicle,**

Veh §615.

**Automotive repair dealer, B&P §9880.1.****Automotive technician.**

Automotive repair dealers, B&P §9880.1.

**Ball joints.**

Trade standards for repairs, CCR  
§16.3360.1.

**BAR.**

Emissions inspections, CCR §16.3340.1.

**BAR-97 emissions inspection system.**

Emissions inspections, CCR §16.3340.1.

**Basic area.**

Emissions inspections, CCR §16.3340.1.

**Basic vehicle inspection and**

**maintenance program area.**

Emissions inspections, CCR §16.3340.1.

**Bidirectional control.**

Air pollution, H&S §39027.3.

**Board, B&P §22.**

Child support enforcement, Fam §17520.

License denial or suspension, B&P §477.

Public members of boards, B&P §452.

**Board within department of consumer**

**affairs.**

Advertising, B&P §17506.5.

**DEFINED TERMS** —Cont'd**Board within department of consumer**

**affairs** —Cont'd

False advertising, B&P §17506.5.

Unfair competition, B&P §17201.5.

**Btu.**

Carl Moyer memorial air quality  
standards attainment program, H&S  
§44275.

**Building.**

Bureau of automotive repair, CCR  
§16.3303.

**Building standard.**

Administrative law, Gov §11342.530.

**Bureau, B&P §22.**

Automotive repair dealers, B&P §9880.1.

Emissions inspections, CCR §16.3340.1.

**Business, Veh §234.****Buyer.**

Warranties, CC §1791.

**CAP.**

Emissions inspections, CCR §16.3340.1.

**Catalog or similar sale.**

Warranties, CC §1791.

**Certificate of compliance, Veh §246.****Certification.**

Arbitration certification program, CCR  
§16.3396.1.

**Certified list.**

Child support enforcement, Fam §17520.

**CFR.**

Emissions inspections, CCR §16.3340.1.

**Change of address.**

Official station licensing, CCR §16.3306.

**Change of ownership.**

Official station licensing, CCR §16.3306.

**Chassis dynamometer.**

Emissions inspections, CCR §16.3340.1.

**Chief.**

Automotive repair dealers, B&P §9880.1.

**CHP.**

Lighting equipment regulation, CCR  
§13.623.

**Clean piping.**

Emissions inspections, CCR §16.3340.1.

**Clothing.**

Warranties, CC §1791.

**Code.**

Bureau of automotive repair, CCR  
§16.3303.

**Collector motor vehicle, Veh §259.****Commercial business agreement.**

Automotive repair dealers, B&P §9880.1.

**Commercial vehicle, Veh §260.**

Bureau of automotive repair, CCR  
§16.3303.

**Commodities law, Gov §12657.****Comparative failure rate (CFR).**

Emissions inspections, CCR §16.3340.1.

**Compensation.**

Bureau of automotive repair, CCR  
§16.3303.

**Compliance with a judgment or order**

**for support.**

Child support enforcement, Fam §17520.

**Component parts for passenger motor**

**vehicles.**

Registration of salvage or dismantled  
vehicles, Veh §5505.

**Computer contaminant, Pen §502.****Computer network, Pen §502.****Computer programs, Pen §502.****Computer services, Pen §502.****Computer system, Pen §502.****Conspicuous.**

Sale of goods, B&P §17533.6.

**Conspicuously.**

Sale of goods, B&P §17533.6.

**DEFINED TERMS** —Cont'd**Construction vehicle.**

Motor vehicles, Veh §27000.

**Consumables.**

Warranties, CC §1791.

**Consumer.**

Arbitration certification program, CCR §16.3396.1.

Consumer affairs department, B&P §302.

**Consumer assistance program (CAP).**

Emissions inspections, CCR §16.3340.1.

**Consumer goods.**

Warranties, CC §1791.

**Conviction, B&P §7.5.****Corrosion protection.**

Bureau of automotive repair, CCR §16.3303.

**Cost-effectiveness.**

Carl Moyer memorial air quality standards attainment program, H&S §44275.

**Cost impact.**

Administrative law, Gov §11342.535.

**Covered emissions.**

Carl Moyer memorial air quality standards attainment program, H&S §44275.

**Covered engine.**

Carl Moyer memorial air quality standards attainment program, H&S §44275.

**Covered person.**

Air pollution, H&S §39027.3.

**Covered source.**

Carl Moyer memorial air quality standards attainment program, H&S §44275.

**Covered vehicle.**

Carl Moyer memorial air quality standards attainment program, H&S §44275.

**Crash part.**

Bureau of automotive repair, CCR §16.3303.

**CRSC.**

Tires, CCR 13.1081.

**Customer.**

Automotive repair dealers, B&P §9880.1.

**Data, Pen §502.****Data stream information.**

Air pollution, H&S §39027.3.

**Days.**

Arbitration certification program, CCR §16.3396.1.

**Dealer, Veh §285.**

Exclusions, Veh §286.

**Dealer invoice.**

Vehicle, B&P §17537.7.

**Declared combined gross weight.**

Vehicle code, Veh §288.

**Declared gross vehicle weight.**

Vehicle code, Veh §289.

**Demonstrator.**

Arbitration certification program, CCR §16.3396.1.

**Department.**

Bureau of automotive repair, CCR §16.3303.

Consumer affairs department, B&P §302.

**Director.**

Automotive repair dealers, B&P §9880.1.

Consumer affairs department, B&P §302.

**Direct threat.**

Discrimination, B&P §125.6.

**Disability.**

Discrimination, B&P §125.6.

**Disabled person, Veh §295.5.****Dismantler.**

Emissions inspections, CCR §16.3340.1.

**DEFINED TERMS** —Cont'd**Distributor, Veh §296.**

Warranties, CC §1791.

**District.**

Carl Moyer memorial air quality standards attainment program, H&S §44275.

**Division.**

Consumer affairs department, B&P §302.

**EIS.**

Emissions inspections, CCR §16.3340.1.

**Emergency, Gov §11342.545.****Emergency vehicle authorized.**

Privately owned, Veh §165.

**Emissions inspection system (EIS).**

Emissions inspections, CCR §16.3340.1.

**Emissions-related motor vehicle information.**

Air pollution, H&S §39027.3.

**Emissions-related motor vehicle part.**

Air pollution, H&S §39027.3.

**Engine change.**

Emissions inspections, CCR §16.3340.1.

**Enhanced area.**

Emissions inspections, CCR §16.3340.1.

**Enhanced data stream information.**

Air pollution, H&S §39027.3.

**Enhanced diagnostic tool.**

Air pollution, H&S §39027.3.

**Enhanced vehicle inspection and maintenance program area.**

Emissions inspections, CCR §16.3340.1.

**Excessive test deviation rate.**

Emissions inspections, CCR §16.3340.1.

**Express warranty.**

Warranties, CC §1791.2.

**False.**

False advertising, dealers, CCR §16.3372.

**Financial instrument, Pen §502.****Financial interest.**

Motor vehicle brake friction material reduction, H&S §25250.50.

**Flash.**

Equipment, warning lamp regulations, CCR §13.811.

**Flashing lamp.**

Equipment, warning lamp regulations, CCR §13.811.

**FMVSS.**

Tires, CCR 13.1081.

**Follow-up pass rate (FPR).**

Emissions inspections, CCR §16.3340.1.

**Fraudulent.**

Licenses, B&P §118.

**Front-end assembly.**

Registration of salvage or dismantled vehicles, Veh §5505.

**Fund.**

Carl Moyer memorial air quality standards attainment program, H&S §44275.

**Garage, Veh §340.****Gaseous fuel.**

Emissions inspections, CCR §16.3340.1.

**Gear shift incident.**

Emissions inspections, CCR §16.3340.1.

**General merchandise retailer, B&P §17537.****Glass, safety, Veh §26704.****Gold shield station.**

Emissions inspections, CCR §16.3340.1.

**Grooves.**

Tires, CCR 13.1081.

**Gross polluter.**

Air pollution, H&S §39032.5.

**Gross vehicle weight rating.**

Vehicle code, Veh §350.

**Heavy duty vehicle.**

Emissions inspections, CCR §16.3340.1.

**DEFINED TERMS** —Cont'd**Heavy duty vehicle** —Cont'd

Motor vehicle brake friction material reduction, H&S §25250.50.

**High polluter.**

Emissions inspections, high polluters repair or removal, H&S §44090.

**Home appliance.**

Warranties, CC §1791.

**Home electronic product.**

Warranties, CC §1791.

**Household.**

Emissions inspections, CCR §16.3340.1.

**Implementation area.**

Emissions inspections, CCR §16.3340.1.

**Implied warranty of fitness.**

Warranties, CC §1791.1.

**Implied warranty of merchantability.**

Warranties, CC §1791.1.

**Implied warranty that goods are merchantable.**

Warranties, CC §1791.1.

**Incremental cost.**

Carl Moyer memorial air quality standards attainment program, H&S §44275.

**Independent automobile expert.**

Arbitration certification program, CCR §16.3396.1.

**Independent repair or service facility.**

Warranties, CC §1791.

**Independent service dealer.**

Warranties, CC §1791.

**Individual.**

Consumer affairs department, B&P §302.

**Initial test.**

Emissions inspections, CCR §16.3340.1.

**Inspector.**

Emissions inspections, CCR §16.3340.1.

**Interests of consumers.**

Consumer affairs department, B&P §302.

**Internet domain name, Pen §502.****Invoice.**

Dealers, disclosure requirements, CCR §16.3352.

Vehicle, B&P §17537.7.

**Lease.**

Warranties, CC §1791.

**Legal owner.**

Motor vehicle, Veh §370.

**Lessee.**

Warranties, CC §1791.

**Lessor, Veh §372.**

Warranties, CC §1791.

**License, B&P §§23.7, 30.**

Child support enforcement, Fam §17520.

Discrimination, B&P §125.6.

License denial or suspension, B&P §477.

**Licensed adjuster.**

Lamp and brake adjusting stations, B&P §9888.1.

Lamp and brake adjusting stations, certificates, B&P §9889.15.

**Licensed station.**

Lamp and brake adjusting stations, B&P §9888.1.

Lamp and brake adjusting stations, certificates, B&P §9889.15.

**Licensee, B&P §30.**

Child support enforcement, Fam §17520.

**Licensing board, B&P §30.****Licentiate, B&P §23.8.****Lighting equipment.**

Motor vehicles, Veh §375.

**Light pulse.**

Equipment, warning lamp regulations, CCR §13.811.

**Light source.**

Equipment, warning lamp regulations, CCR §13.811.

**DEFINED TERMS —Cont'd****Local agency.**

Public records act, Gov §6252.

**Local consumer affairs agency.**

Advertising, B&P §17506.5.

False advertising, B&P §17506.5.

Unfair competition, B&P §17201.5.

**Low-speed vehicle,** Veh §385.5.**Major component parts for motorcycles.**

Registration of salvage or dismantled vehicles, Veh §5505.

**Major component parts for trucks, truck-type or bus-type vehicles.**

Registration of salvage or dismantled vehicles, Veh §5505.

**Major grooves.**

Tires, CCR 13.1081.

**Major regulation.**

Administrative law, Gov §11342.548.

**Manufacturer,** CC §1795.6.

Arbitration certification program, CCR §16.3396.1.

Dispute resolution for new motor vehicle warranties, B&P §472.

Motor vehicle brake friction material reduction, H&S §25250.50.

Warranties, CC §1791.

**Marketing channel,** B&P §17537.**Material.**

License denial, suspension or revocation, B&P §478.

**Member of the Armed Forces.**

Warranties, CC §1791.

**Member of the public.**

Public records act, Gov §6252.

**Minor component parts for motorcycles.**

Registration of salvage or dismantled vehicles, Veh §5505.

**Misleading.**

False advertising, dealers, CCR §16.3372.

**Mobile source air pollution reduction review committee.**

Carl Moyer memorial air quality standards attainment program, H&S §44275.

**Motorcycle,** Veh §400.**Motor truck,** Veh §410.**Motor vehicles,** Veh §415.

Automotive repair dealers, B&P §9880.1.

Muffler, Veh §425.

Power brakes, Veh §480.

Service contracts, Ins §12800.

**Multipurpose passenger vehicles.**

Tires, CCR 13.1081.

**New motor vehicle.**

Arbitration certification program, CCR §16.3396.1.

Dispute resolution, B&P §472.

**New motor vehicle dealer,** Veh §426.**New vehicle,** Veh §430.**New very low emission vehicle.**

Carl Moyer memorial air quality standards attainment program, H&S §44275.

**Noncompliance.**

Office of Administrative Law, review of regulations, Gov §11349.1.

**Nonconformity.**

Arbitration certification program, CCR §16.3396.1.

**Non-directed vehicle.**

Emissions inspections, CCR §16.3340.1.

**Non-original equipment manufacturer (non-OEM) aftermarket crash part.**

Bureau of automotive repair, CCR §16.3303.

**Nonrepairable vehicle,** Veh §431.**DEFINED TERMS —Cont'd****Nonrepairable vehicle certificate,** Veh §432.**NOx.**

Carl Moyer memorial air quality standards attainment program, H&S §44275.

**OBD inspection system.**

Emissions inspections, CCR §16.3340.1.

**Obligor.**

Service contracts, Ins §12800.

**Offstreet public parking facility,** Veh §4000.**OIS.**

Emissions inspections, CCR §16.3340.1.

**Order of repeal.**

Administrative law, Gov §11342.560.

**Original equipment lighting device.**

Lighting equipment regulation, CCR §13.623.

**Original equipment manufacturer (OEM) crash part.**

Bureau of automotive repair, CCR §16.3303.

**Owner,** Veh §460.**Paging.**

Illuminated signs on public transit buses, Veh §25353.

**Parts car,** Veh §5051.**Passenger cars.**

Tires, CCR 13.1081.

**Passenger vehicle,** Veh §465.

Bureau of automotive repair, CCR §16.3303.

**Performance standards.**

Administrative law, Gov §11342.570.

**Perjury,** Pen §118.**Person.**

Advertising, B&P §17506.

Automotive repair dealers, B&P §9880.1.

Consumer affairs department, B&P §302.

False advertising, B&P §17506.

Public records act, Gov §6252.

Sale of equipment or services for use in violation of license requirements, B&P §128.

Unfair competition, B&P §17201.

**Pickup truck,** Veh §471.**Place of business.**

Warranties, CC §1791.

**Plain English.**

Administrative law, Gov §11342.580.

**Prescriptive standard.**

Administrative law, Gov §11342.590.

**Program.**

Carl Moyer memorial air quality standards attainment program, H&S §44275.

Emissions inspections, CCR §16.3340.1.

**Proposed action.**

Administrative law, Gov §11342.595.

**Public agency.**

Public records act, Gov §6252.

**Public records.**

Public records act, Gov §6252.

**Purchaser.**

Service contracts, Ins §12800.

**Qualified third party dispute resolution process.**

Dispute resolution for new motor vehicle warranties, B&P §472.

**Rear clip.**

Registration of salvage or dismantled vehicles, Veh §5505.

**Recreational vehicle.**

Bureau of automotive repair, CCR §16.3303.

**Referee.**

Emissions inspections, CCR §16.3340.1.

**DEFINED TERMS —Cont'd****Reflector.**

Equipment, reflex reflectors on front of vehicle, CCR §13.761.

**Reflex reflector.**

Equipment, reflex reflectors on front of vehicle, CCR §13.761.

**Registered owner or lessee,** Veh §505.

Smog impact fee refunds, Veh §1673.

**Registered within area designated for program coverage.**

Emissions inspections, certificate of compliance, H&S §44011.1.

**Regroovable tires.**

Tires, CCR 13.1081.

**Regrooved tires.**

Tires, CCR 13.1081.

**Regulations.**

Administrative law, Gov §11342.600.

**Repair assistance.**

Emissions inspections, CCR §16.3340.1.

**Repair of motor vehicles.**

Automotive repair dealers, B&P §9880.1.  
Bureau of automotive repair, CCR §16.3303.

**Repair-only station.**

Emissions inspections, CCR §16.3340.1.

**Repair shop,** Veh §510.**Repair technician.**

Emissions inspections, CCR §16.3340.1.

**Replacement lens.**

Equipment, replacement lenses, CCR §13.766.

**Repossessors' tow vehicle,** Veh §615.**Repower.**

Carl Moyer memorial air quality standards attainment program, H&S §44275.

**Reserve lighting and outage indicator system.**

Equipment, reserve lighting and outage indicators, CCR §13.771.

**Retail buyer.**

Warranties, CC §1791.

**Retailer.**

Warranties, CC §1791.

**Retail seller.**

Warranties, CC §1791.

**Retrofit.**

Carl Moyer memorial air quality standards attainment program, H&S §44275.

**Return to the retail seller.**

Warranties, CC §1791.

**Revivable junk receipt.**

Emissions inspections, CCR §16.3340.1.

**Revived salvage vehicle,** Veh §521.5.**Safe and available.**

Motor vehicle brake friction material reduction, H&S §25250.54.

**Safety glass,** Veh §26704.**Sale.**

Warranties, CC §1791.

**Salvage vehicle rebuilder,** Veh §543.5.**Sealed optical unit.**

Lighting equipment regulation, CCR §13.623.

**Section.**

Bureau of automotive repair, CCR §16.3303.

**Sectioning.**

Bureau of automotive repair, CCR §16.3303.

**Securities law,** Gov §12657.**Seller.**

Service contracts, Ins §12800.  
Warranties, CC §1791.

**Semisealed optical unit.**

Lighting equipment regulation, CCR §13.623.

**DEFINED TERMS** —Cont'd

- Service**, Pen §502.  
**Service contract.**  
 Warranties, CC §1791.  
**Service contract administrator.**  
 Service contracts, Ins §12800.  
**Side-mounted turn signal lamp.**  
 Equipment, side-mounted and supplemental signal lamps, CCR §13.791.  
**Similar vehicle failure rate (SVFR).**  
 Emissions inspections, CCR §16.3340.1.  
**Similar vehicles.**  
 Emissions inspections, CCR §16.3340.1.  
**Small business.**  
 Administrative law, Gov §11342.610.  
**Smog check inspector.**  
 Emissions inspections, CCR §16.3340.1.  
**Smog check program.**  
 Emissions inspections, CCR §16.3340.1.  
**Smog check referee.**  
 Emissions inspections, CCR §16.3340.1.  
**Smog check repair technician.**  
 Emissions inspections, CCR §16.3340.1.  
**Smog check station.**  
 Emissions inspections, CCR §16.3340.1.  
**Smog check technician.**  
 Emissions inspections, CCR §16.3340.1.  
**Smog check test-and-repair station.**  
 Emissions inspections, CCR §16.3340.1.  
**Smog check test-only station.**  
 Emissions inspections, CCR §16.3340.1.  
**Specially constructed vehicle**, Veh §580.  
**STAR.**  
 Emissions inspections, CCR §16.3340.1.  
**State agency.**  
 Public records act, Gov §6252.  
**State board.**  
 Vehicular air pollution, H&S §39053.  
**Station.**  
 Emissions inspections, CCR §16.3340.1.  
 Lamp and brake adjusting stations, B&P §9888.1.  
 Lamp and brake adjusting stations, certificates, B&P §9889.15.  
**Steady burning lamp.**  
 Equipment, warning lamp regulations, CCR §13.811.  
**Streaming.**  
 Illuminated signs on public transit buses, Veh §25353.  
**Street rod vehicle**, Veh §5051.  
**Structure.**  
 Bureau of automotive repair, CCR §16.3303.  
**Substantial nonconformity.**  
 Arbitration certification program, CCR §16.3396.1.  
**Supervising technician.**  
 Emissions inspections, CCR §16.3340.1.  
**Supplemental rear turn signal lamp.**  
 Equipment, side-mounted and supplemental signal lamps, CCR §13.791.  
**Supplemental restraint system**, Veh §593.  
**Supplemental stoplamp.**  
 Equipment, side-mounted and supplemental signal lamps, CCR §13.791.  
**Supporting documentation**, Pen §502.  
**SVFR.**  
 Emissions inspections, CCR §16.3340.1.  
**Tax obligation.**  
 Business and occupational licenses, B&P §31.  
**Technician.**  
 Emissions inspections, CCR §16.3340.1.

**DEFINED TERMS** —Cont'd

- Technician information table.**  
 Emissions inspections, CCR §16.3340.1.  
**Test-and-repair station.**  
 Emissions inspections, CCR §16.3340.1.  
**Test deviation.**  
 Emissions inspections, CCR §16.3340.1.  
**Testing certification agency.**  
 Motor vehicle brake friction material reduction, H&S §25250.50.  
**Test-only station.**  
 Emissions inspections, CCR §16.3340.1.  
**Tow truck**, Veh §615.  
**Transmission fluid change.**  
 Bureau of automotive repair, CCR §16.3303.  
**Tread patterns.**  
 Tires, CCR §13.1081.  
**Tread wear indicators.**  
 Tires, CCR §13.1081.  
**Truck, motor**, Veh §410.  
**TSI.**  
 Emissions inspections, CCR §16.3340.1.  
**Two-speed idle (TSI).**  
 Emissions inspections, CCR §16.3340.1.  
**Unfair competition**, B&P §17200.  
**Used vehicle**, Veh §665.  
**Vehicle**, Veh §670.  
**Vehicle frame**, Veh §670.5.  
**Vehicle identification number**, Veh §671.  
**Vehicle information database (VID).**  
 Emissions inspections, CCR §16.3340.1.  
**Vehicle inspection report (VIR).**  
 Emissions inspections, CCR §16.3340.1.  
**Vehicle manufacturer**, Veh §672.  
**Vehicle, motor**, Veh §415.  
**Vehicle protection products.**  
 Automobile warranties, Ins §116.6.  
**Vehicle retirement.**  
 Emissions inspections, CCR §16.3340.1.  
**Vehicle service contract**, Ins §12800.  
**Very low emission vehicle.**  
 Carl Moyer memorial air quality standards attainment program, H&S §44275.  
**VID.**  
 Emissions inspections, CCR §16.3340.1.  
**VIR.**  
 Emissions inspections, CCR §16.3340.1.  
**VLT row ID.**  
 Emissions inspections, CCR §16.3340.1.  
**Voluntarily submitted.**  
 Public records disclosure exemptions, Gov §6254.  
**Warning lamp.**  
 Equipment, warning lamp regulations, CCR §13.811.  
**Warning lamp assembly.**  
 Equipment, warning lamp regulations, CCR §13.811.  
**Warning lamp housing.**  
 Equipment, warning lamp regulations, CCR §13.811.  
**Warning lamp unit.**  
 Equipment, warning lamp regulations, CCR §13.811.  
**Warrantor.**  
 Automobile warranties, Ins §116.6.  
**Watercraft.**  
 Service contracts, Ins §12800.  
**Wholesale price.**  
 Vehicle, B&P §17537.7.  
**With all faults.**  
 Warranties, CC §1791.3.  
**Work order.**  
 Dealers, disclosure requirements, CCR §16.3352.

**DEFINED TERMS** —Cont'd

- Writing**, Gov §6252.  
 Public records act, Gov §6252.  
**Written estimate.**  
 Dealers, disclosure requirements, CCR §16.3352.  
**Written warranty.**  
 Arbitration certification program, CCR §16.3396.1.  
**DIESEL ENGINES.**  
**Air pollution.**  
 Vehicular air pollution control.  
 Used vehicles.  
 Heavy-duty vehicles, H&S §§43700, 43701.  
**DISABLED PERSONS.**  
**Americans with disabilities act.**  
 Rulemaking in conformity to, B&P §313.2.  
**Parking spaces.**  
 Disabled person and disabled veteran, defined, Veh §295.5.  
**Service stations.**  
 Refueling service for disabled persons, B&P §13660.  
**Unfair competition.**  
 Senior citizen as victim.  
 Fines, B&P §17206.1.  
**Wheelchairs and other mobility aids.**  
 Vehicle operator, user as pedestrian rather than, Veh §415.  
**DISASTER SERVICE WORKERS.**  
**Equipment for vehicles.**  
 Flashing or warning lights.  
 Red cross, Veh §25259.5.  
**DISCIPLINARY ACTIONS AGAINST LICENSES.**  
**Administrative procedure**, CCR §16.3395.4.  
**Cash payments of employee wages**, B&P §140.  
**Dealers.**  
 Registration.  
 Relationship of act to fitness to perform under registration, CCR §16.3395.2.  
**Denial of licenses generally.**  
 See LICENSES.  
**Drug diversion.**  
 Effect of completion upon disciplinary action, B&P §492.  
**Emissions inspections.**  
 Fleet owner licensing, CCR §16.3340.50.5.  
 Licensing under chapter, H&S §§44072 to 44072.11.  
**Foreign jurisdictions.**  
 Grounds for discipline in California, B&P §141.  
**Lamp and brake adjusting stations.**  
 Denial, suspension and revocation, B&P §§9889.1 to 9889.10.  
 Administrative procedure, CCR §16.3395.4.  
**Parts.**  
 Automotive parts sales.  
 Violation as grounds for discipline, CCR §16.3395.3.  
**Public access to information**, CCR §16.3303.1.  
**Public reprovals**, B&P §495.  
**Suspension or revocation of licenses generally.**  
 See LICENSES.  
**DISCOVERY.**  
**State departments and agencies.**  
 Investigations, Gov §§11186, 11187, 11189.

**DISCRIMINATION.**

**Licensees, discrimination by, B&P** §125.6.

**Public records act.**

Allowing access to writing.  
Discrimination among or between members of legislative body or local agency, Gov §6253.3.

**DISMANTLERS.**

**Definitions, Veh** §§220, 221.

**Revived salvage vehicles.**

Sale or transfer of vehicles, inspection compliance, Veh §5506.

**Salvage vehicle rebuilders.**

Sale or transfer of vehicles, inspection compliance, Veh §5506.

**Salvage vehicles, inspections, Veh** §5505.

Sale or transfer of vehicles, Veh §5506.

**Total loss salvage vehicles, Veh** §§11515.

Inspection to determine identity, Veh §5505.

Sale or transfer of vehicles after inspection, Veh §5506.

**Tow trucks, identification, Veh** §615.**DISPUTE RESOLUTION.**

**Arbitration certification program, CCR** §§16.3396.1 to 3397.5.

See ARBITRATION CERTIFICATION PROGRAM.

**New motor vehicle warranties.**

Certification, B&P §§472 to 472.5.  
Requirements for dispute resolution generally, CC §1793.22.

**DIVISION OF CONSUMER SERVICES.**

**Chief, B&P** §303.

**Established, B&P** §303.

**DOOR-TO-DOOR SALES.**

**Solicitation of sales at residence or by telephone, B&P** §17500.3.

**DRIVERS' LICENSES.****Child support enforcement.**

Withholding issuance or renewal of licenses, Fam §17520.

**Suspension or revocation.**

Forfeiture of vehicle, Veh §14607.6.  
Nuisance, motor vehicles operated without valid driver's license subject to forfeiture as, Veh §14607.6.

**Towing arrangements.**

Inducements to public agencies to make towing arrangements.  
Suspension of license for violation, Veh §13351.85.

**DRIVING UNDER THE INFLUENCE.****Vehicle inspection and sobriety checkpoint program.**

Inspection stickers and fees to fund program, Veh §2814.  
Use of fines from proceedings to fund program, Pen §1463.15.

## E

**ELECTRIC VEHICLES.****Neighborhood electric vehicles.**

Definition, Veh §385.5.

**EMERGENCY VEHICLES.**

**Air horns, Veh** §27000.

**Definitions, Veh** §165.

**Equipment for vehicles.**

Flashing or warning lights, Veh §25252.  
Additional lights, Veh §25259.  
Blue lights, flashing, Veh §25258.  
Headlamps, Veh §25252.5.

**EMERGENCY VEHICLES —Cont'd****Equipment for vehicles —Cont'd**

Flashing or warning lights —Cont'd  
Red cross, Veh §25259.5.

Warning lamp regulations, CCR §13.818.

White lights, flashing, Veh §25258.

Side and fender lighting.

Clearance and side-marker lamps.

Ambulances, Veh §25100.1.

**Sirens and red lights.**

Unlawful use, Veh §27002, 27003.

**EMISSIONS CONTROL LABEL,**

Rev&Tax §6263.

**EMISSIONS INSPECTIONS, CCR**

§§16.3340.1 to 16.3340.50.5, H&S

§§44000 to 44122.

**Accelerated retirement of light-duty**

**vehicles, H&S** §§44100 to 44122.

See AIR POLLUTION.

**Adoption of standards, H&S** §43013.**Air pollution generally.**

See AIR POLLUTION.

**Bar code labels.**

Providing to vehicle owners, H&S §44041.

**Bureau of automotive repair.**

Responsibilities under chapter, H&S §44001.5.

**Carl Moyer memorial air quality standards attainment program,**

H&S §§44275 to 44299.2.

See AIR POLLUTION.

**Certificate of compliance, H&S** §44011.

Exemptions.

Proof of exemptions, H&S §44011.5.

Fees, CCR §§16.3340.35, 16.3340.35.1.

Form, H&S §44060.

Ineligible vehicles, H&S §44015.

Noncertified engines or vehicles.

Denial of certificate, H&S §44015.5.

Numbering to identify, H&S §44040.

Pretesting, H&S §44011.3.

Public agency vehicles, H&S §44019.

Registered within area designated for program coverage.

Defined, H&S §44011.1.

Registration of vehicles.

Biennial certification, Veh §4000.3.

Certificate as prerequisite to registration, Veh §§4000.1, 4000.2.

Statistical and emissions profiles of vehicles.

Use of statistics to exempt vehicles from biennial certification, H&S §44024.5.

Test-only facilities.

Percentage of vehicles required to obtain certificate from test-only facility, H&S §44014.7.

**Certificate of noncompliance.**

Numbering to identify, H&S §44040.

**Change of ownership, CCR** §16.3340.6.**Citations, H&S** §44050.

Fine schedule, H&S §44051.

Failure to pay, H&S §44055.

Separate violations, H&S §44052.

Violations outside of schedule, H&S §44056.

**Clean air act implementation fees.**

District fees, H&S §§44225, 44229.

**Clearing enforcement forms, CCR**

§16.3340.36.

**Conflict of laws, Veh** §24007.6.

Chapter supersedes other emissions inspections programs, H&S §44004.

**Consumer affairs department.**

Powers of department, H&S §44002.

**EMISSIONS INSPECTIONS —Cont'd****Consumer assistance program, CCR**

§§16.3394.1 to 16.3394.7.

Administration, CCR §16.3394.2.

Application, CCR §§16.3394.6, 16.3394.7.

Components, CCR §16.3394.1.

Eligibility, CCR §16.3394.4.

Limits on state assistance, CCR §16.3394.3.

Purpose, CCR §16.3394.1.

Vehicles ineligible for program, CCR §16.3394.5.

**Credits for emission reductions.**

Accelerated retirement of light-duty vehicles.

Certification and use of emission reduction credits, H&S §44121.

Emission credit exchange program, H&S §44062.2.

Marketable emission reduction credits, H&S §44062.2.

Gross polluters, H&S §44085.

**Definitions, CCR** §16.3340.1.**Emission credit exchange program,**

H&S §44062.2.

**Enhanced inspection and maintenance**

**program.**

Certain nonattainment areas, H&S §44003.

San Francisco Bay area basin, H&S §44003.5.

Test-only facilities.

Certificate of compliance.

Percentage of vehicles required to obtain certificate from test-only facility, H&S §44014.7.

Program for testing at test-only facilities, H&S §44010.5.

Standards, H&S §44014.5.

**Exemptions.**

Proof of exemptions, H&S §44011.5.

Vehicles exempt from inspection, CCR §16.3340.5.

**Exhaust system certificate of**

**compliance.**

Fee, CCR §16.3340.36.1.

**False statements, entries, etc.**

Perjury, H&S §44059.

**Fines and citations.**

Amounts of fines, CCR 16.3394.26.

Authority to issue, CCR 16.3394.25.

Compliance with citations/orders of abatement, CCR 16.3394.27.

**Fleet owner testing and servicing.**

Citation, H&S §44050.

Generally. See within this heading, "Citations."

Licensing fleet owner, H&S §44020.

Application, renewal, etc., CCR §16.3340.50.1.

Certificates, CCR §16.3340.50.4.

Recordkeeping, CCR §16.3340.50.3.

Requirements, CCR §16.3340.50.

Suspension or rescission, CCR §16.3340.50.5.

Administrative procedure, CCR §16.3395.4.

**Frequency of inspection, H&S** §44005.**Fuel efficiency checks.**

Advisory safety and fuel efficiency checks, H&S §44018.

**Gross polluters, H&S** §§44080 to 44086.

Cost effectiveness, H&S §44086.

High polluters, repair or removal, H&S §44090 to 44096.

Identification, H&S §44081.

Legislative intent, H&S §44080.

Marketable emission reduction credits, H&S §44085.



**EMISSIONS INSPECTIONS —Cont'd****Gross polluters —Cont'd**

Pilot demonstration program, H&S §44081.6.

Repairable situations, H&S §44084.

**Heavy duty vehicles.**

Defined, CCR §16.3340.1.

Emissions standards and procedures, H&S §43701.

**High polluters, repair or removal, H&S §§44090 to 44096.**

Account.

Defined, H&S §44090.

High polluter repair or removal account, H&S §44091.

Administration of program, H&S §44095.

Contents of program, H&S §44094.

Definitions, H&S §44090.

Design of program, H&S §44092.

High polluter repair or removal account, H&S §44091.

Defined, H&S §44090.

Light-duty vehicles, emissions reduction devices.

Cost effectiveness assessments, H&S §44096.

Participation in program, H&S §44094.

Purpose of program, H&S §44093.

Smog abatement fee.

Increase if smog impact fee ruled uncollectible, H&S §44091.1.

Smog impact fee.

Increase in other fees if ruled uncollectible, H&S §44091.1.

Legislative intent if ruled uncollectible, H&S §44091.2.

**Information to the public.**

Public information program generally, H&S §§44070 to 44071.

**Initial registration, CCR §16.3340.6.****Injunctions and restraining orders against violations, H&S §44057.****Inspection program.**

Inspection-based performance standards, H&S §44014.6.

**Invoices, CCR §16.3340.41.3.****Kit vehicles.**

Standards for inspections, H&S §44017.4.

**Legislative intent, H&S §§44000 to 44001.3.****Light-duty vehicles, emissions reduction devices.**

Cost effectiveness assessments, H&S §44096.

**Low income repair assistance program, H&S §44062.1.****Maintenance of vehicles.**

Specifications, H&S §44016.

Vendors possessing service information. Department as clearinghouse, H&S §44025.

**Marketable emission reduction credits, H&S §44062.2.**

Gross polluters, H&S §44085.

**Maximum emissions standards.**

Department to set, H&S §44013.

**Misdemeanor violations, H&S §44058.****New motor vehicles, H&S §§43104, 43105.5.**

Acquisition of vehicle or engine.

Non-certified for sale or resale, H&S §43152.

Outside of state, H&S §43151.

Action for civil penalty, H&S §43154.

Precedence, H&S §43155.

Legislative findings, H&S §43150.

Sale or lease of non-certified vehicle or engine, H&S §43153.

**EMISSIONS INSPECTIONS —Cont'd****New motor vehicles —Cont'd**

Transfer of title based on odometer reading, H&S §43156.

**New technologies.**

Investigation, H&S §44024.

**Noise emissions, Veh §24011.7.****NOx devices.**

Installation on certain older vehicles, CCR §16.3340.37.

**Onboard diagnostic systems.**

Investigation of new technologies, H&S §44024.

**Perjury.**

Conduct constituting, H&S §44059.

Criminal provisions governing perjury, Pen §§118, 126.

Subornation of perjury, Pen §127.

**Pretesting, H&S §44011.3.****Procedures for testing.**

Department to set, H&S §44013.

**Public agency vehicles.**

Certificate of compliance, H&S §44019.

**Public information program, H&S §44070.**

Funding, H&S §44071.

Included items, H&S §44070.5.

**Quality assurance, H&S §§44030 to 44045.6.****Records of tests and repairs.**

Bar code labels, H&S §44041.

Certificates of compliance and noncompliance.

Numbering to identify, H&S §44040.

Contents, H&S §44037.

Database.

Centralized database, H&S §44037.1.

Contracting for administration, H&S §44037.2.

Publication of summary of information gleaned, H&S §44039.

Repair cost waivers.

Numbering to identify, H&S §44040.

Transmitting information to department, H&S §44038.

**Referee stations.**

Alternative weekday schedule, H&S §44017.5.

Certification of test equipment, H&S §44036.

**Registration of vehicles.**

Transfers of title or interest.

Emissions statement, Veh §5751.5.

**Regulations.**

Suspension or revocation by director, H&S §44072.

**Repair cost limit, CCR §16.3340.43.****Repair of vehicles.**

Conditioning performance of smog test on having repairs done at same station, H&S §44033.

Costs.

Consumer assistance program, CCR §§16.3394.1 to 16.3394.7.

Economic hardship extension, H&S §44017.1.

Fees, CCR §§16.3340.35, 16.3340.35.1.

Low income repair assistance program.

High polluters, repair or removal, H&S §§44090 to 44096.

Maximum amounts.

Posting, H&S §44017.3.

Signs, CCR §16.3340.22.2.

Minimum amounts.

Posting, H&S §44017.3.

Signs, CCR §16.3340.22.2.

Repair cost waiver, H&S §44017.

Fees, CCR §§16.3340.35, 16.3340.35.1.

**EMISSIONS INSPECTIONS —Cont'd****Repair of vehicles —Cont'd**

Costs —Cont'd

Repair cost waiver —Cont'd

Form, H&S §44060.

Low income vehicle owners, H&S §44017.1.

Definition of low income vehicle owner, H&S §44017.1.

Numbering to identify, H&S §44040.

Gross polluters.

Repairable situations, H&S §44084.

High polluters, repair or removal, H&S §§44090 to 44096.

Low income repair assistance program, H&S §44062.1.

High polluters, repair or removal, H&S §§44090 to 44096.

Specifications, H&S §44016.

Vendors possessing service information.

Department as clearinghouse, H&S §44025.

**Retrofit device installations.**

Certification of emissions retrofit device installations, H&S §44013.5.

**Right of entry for inspection, H&S §43012.****Safety checks.**

Advisory safety and fuel efficiency checks, H&S §44018.

**Smog abatement fee increase.**

Distribution of revenues, H&S §44060.5.

**Smog check stations.**

Calibration gases.

Certifying and decertifying gas blenders, H&S §44036.5.

Citation, H&S §44050.

Data from equipment as evidence to appeal, H&S §44036.8.

Generally. See within this heading, "Citations."

Conditioning test on having repairs done at same station, H&S §44033.

Consumer assistance program, CCR §§16.3394.1 to 16.3394.7.

Defined, CCR §16.3340.1.

Equipment of stations.

Calibration gases.

Certifying and decertifying gas blenders, H&S §44036.5.

Certification and testing, H&S §44036.

Improvement of effectiveness of inspections.

Private sources of information, H&S §44036.3.

Manufacturers' proof of financial security, H&S §44036.1.

Service of equipment.

Manufacturers' duty to provide information, H&S §44036.2.

Fees of department, H&S §44060.

Gold shield program (GSP), CCR §§16.3392.1 to 16.3392.6.

See GOLD SHIELD PROGRAM (GSP).

Licensing of stations and technicians, H&S §44014.

Ceasing operation as licensed station, CCR §16.3340.23.

Certification, voluntary, H&S §44014.2.

Advertising certification, H&S §44014.4.

Denial of license.

Administrative procedure, CCR §16.3395.4.

Convictions, H&S §44072.3.

Grounds, H&S §44072.1.

Fees, H&S §44034.

Fines, failure to pay.

Nonrenewal of license, H&S §44055.

**EMISSIONS INSPECTIONS —Cont'd**

**Smog check stations —Cont'd**  
 Licensing of stations and technicians —Cont'd  
 Probation and terms.  
 Types of discipline, H&S §44072.4.  
 Procedure, CCR §16.3340.10.  
 Refusal to renew or to issue new license, H&S §44072.11.  
 Standards, H&S §44030.  
 Suspension or revocation, H&S §§44035, 44072.  
 Additional licenses, H&S §44072.8.  
 Administrative procedure, CCR §16.3395.4.  
 Authority of bureau, CCR §16.3340.24.  
 Convictions, H&S §44072.3.  
 Grounds, H&S §44072.2.  
 Jurisdiction, H&S §44072.6.  
 Limitations period, H&S §44072.7.  
 Reinstatement of license, H&S §44072.9.  
 Authority of bureau, CCR §16.3340.24.  
 Surrender of license, H&S §44072.5.  
 Temporary suspension, H&S §44072.10.  
 Types of discipline, H&S §44072.4.  
 Types of stations, H&S §44033.  
 Prerequisites to performing tests or repairs, H&S §44032.  
 Private stations, H&S §44010.  
 Repair-only stations.  
 Types of stations, H&S §44033.  
 Retiring of vehicle failing smog check inspection, H&S §44062.3.  
 Signs, CCR §16.3340.22.  
 Repair cost limit signs, CCR §16.3340.22.2.  
 Replacement, CCR §16.3340.22.3.  
 Service signs, CCR §16.3340.22.1.  
 Technicians. See within this heading, "Technicians."  
 Test and repair facilities.  
 Types of stations, H&S §44033.  
 Testing procedures, CCR §16.3340.42.  
 On-board diagnostic inspection, CCR §16.3340.42.2.  
 Smog check manual, CCR §16.3340.45.  
 Test-only facilities.  
 Types of stations, H&S §44033.  
 Training of mechanics.  
 Standards, H&S §44030.5.  
 Types of tests required, H&S §44012.  
 Work area, staffing, displays, etc., CCR §16.3340.15.  
**Smog check technicians.** See within this heading, "Technicians."  
**Smoke emissions testing,** H&S §44011.6.  
 Visible smoke test, H&S §44012.1.  
 Failure to pass, H&S §44017.  
**Specially constructed vehicles.**  
 Standards for inspections, H&S §44017.4.  
**State vehicle fleet.**  
 Test-only facilities.  
 Program for testing at test-only facilities, H&S §44010.5.  
**Statistical and emissions profiles of vehicles,** H&S §44024.5.  
**Tampering.**  
 Certificate of compliance.  
 Ineligible vehicles, H&S §44015.  
 Emissions control system tampering, CCR §16.3340.41.5.  
 Temporary suspension of licenses issued under chapter, H&S §44072.10.  
**Technicians.**  
 Citation, H&S §44050.  
 Data from equipment as evidence to appeal citation, H&S §44036.8.

**EMISSIONS INSPECTIONS —Cont'd**

**Technicians —Cont'd**  
 Citation —Cont'd  
 Generally. See within this heading, "Citations."  
 Defined, CCR §16.3340.1.  
 Licensing of stations and technicians, H&S §44014.  
 Categories of licensure, H&S §44045.5.  
 Certification of technician trainers, CCR §§16.3340.32, 16.3340.33.  
 Classification of technicians, CCR §16.3340.28.  
 Decertification and recertification of technician trainers, CCR §§16.3340.32.1, 16.3340.33.1.  
 Denial of license.  
 Administrative procedure, CCR §16.3395.4.  
 Convictions, H&S §44072.3.  
 Grounds, H&S §44072.1.  
 Fees, H&S §44034.  
 Examination fees for technicians, H&S §44034.1.  
 Fines, failure to pay.  
 Nonrenewal of license, H&S §44055.  
 Ongoing requirements of technicians, CCR §16.3340.30.  
 Probation and terms.  
 Types of discipline, H&S §44072.4.  
 Procedure, CCR §16.3340.29.  
 Qualifications, H&S §44045.5.  
 Qualifications and requirements for technicians, H&S §44031.5.  
 Qualifications of technicians, CCR §16.3340.28.  
 Refusal to renew or to issue new license, H&S §44072.11.  
 Retraining, CCR §16.3340.31.  
 Suspension or revocation, H&S §§44035, 44072.  
 Additional licenses, H&S §44072.8.  
 Administrative procedure, CCR §16.3395.4.  
 Convictions, H&S §44072.3.  
 Grounds, H&S §44072.2.  
 Jurisdiction, H&S §44072.6.  
 Limitations period, H&S §44072.7.  
 Reinstatement of license, H&S §44072.9.  
 Surrender of license, H&S §44072.5.  
 Temporary suspension, H&S §44072.10.  
 Types of discipline, H&S §44072.4.  
 Prerequisites to performing tests or repairs, H&S §44032.  
 Qualifications, H&S §44045.5.  
 Testing procedures, CCR §16.3340.42.  
 On-board diagnostic inspection, CCR §16.3340.42.2.  
 Smog check manual, CCR §16.3340.45.  
 Training requirements, H&S §44045.6.  
 Certification of technician trainers, CCR §16.3340.32.  
 Decertification and recertification of trainers, CCR §§16.3340.32.1, 16.3340.33.1.  
 Retraining, CCR §16.3340.31.  
**Test analyzer system.**  
 Calibration and maintenance of equipment, CCR §16.3340.17.  
 Certification, CCR §16.3340.18.  
 Certification of calibration gases and blenders, CCR §16.3340.18.  
 Citations, CCR §16.3340.17.2.  
 Decertification of equipment manufactures, CCR §16.3340.17.1.  
 Defined, CCR §16.3340.1.  
 Procedures for testing, CCR §16.3340.42.

**EMISSIONS INSPECTIONS —Cont'd**

**Test analyzer system —Cont'd**  
 Reports to customer, CCR §16.3340.41.  
**Test-and-repair stations.**  
 Defined, CCR §16.3340.1.  
 Requirements, CCR §16.3340.16.5.  
**Test-only facilities.**  
 Certificate of compliance.  
 Percentage of vehicles required to obtain certificate from test-only facility, H&S §44014.7.  
 Citation, H&S §44050.  
 Generally. See within this heading, "Citations."  
 Defined, CCR §16.3340.1.  
 Equipment, work area, documentation, etc., CCR §16.3340.16.  
 Fees, CCR §16.3340.7.  
 Program for testing at test-only facilities, H&S §44010.5.  
 Referrals to repair facilities, CCR §16.3340.41.  
 Standards, H&S §44014.5.  
 Types of smog check stations, H&S §44033.  
**Types of tests required,** H&S §44012.  
**Unlicensed activity.**  
 Administrative citations and fines, CCR §§16.3394.40 to 16.3394.46.  
**Vehicle inspection and repair fund.**  
 Abolition of predecessor funds and transfer of proceeds into current fund, H&S §44062.  
 Fines and fees deposited into fund, H&S §§44060, 44061.  
 High polluter repair or removal account, H&S §§44090, 44091.  
 Litigation proceeds from certain case transferred to fund, H&S §44063.  
**Visible smoke test,** H&S §44012.1.  
 Failure to pass, H&S §44017.  
**EMPLOYER IDENTIFICATION NUMBERS.**  
**Licensee to supply,** B&P §30.  
**EQUIPMENT FOR VEHICLES.**  
**Air bags.**  
 Previously deployed air bags, Veh §27317.  
**Airbrakes,** Veh §§26502 to 26508.  
**Air pollution control devices,** Veh §27156.  
 Disconnecting, modifying, etc., Veh §42001.14.  
**Applicability of provisions,** Veh §24001.  
**Brake lights,** Veh §24603.  
 Side-mounted and supplemental signal lamps, CCR §§13.790 to 13.794.  
**Brakes,** Veh §§26301 to 26522.  
 Adjusting stations.  
 See LAMP AND BRAKE ADJUSTING STATIONS.  
 Airbrakes, Veh §§26502 to 26508.  
 Air governor, Veh §26504.  
 Adjustment, CCR §13.1061.  
 Check valves, Veh §26507.  
 Emergency stopping system, Veh §26508.  
 Load-controlled air pressure reducing system, CCR §13.1063.  
 Pressure gauge, Veh §26505.  
 Safety valve, Veh §26503.  
 Adjustment, CCR §13.1062.  
 Special devices or adjustments, Veh §26502.  
 Warning device, Veh §26506.  
 Breakaway brakes, Veh §26304.  
 Control requirements, Veh §26454.

**EQUIPMENT FOR VEHICLES —Cont'd****Brakes —Cont'd**

Dolly brakes.

Auxiliary dolly or tow dolly brakes, Veh §26305.

Emergency brakes, Veh §26301.5.

Engine failure.

Operation of brakes, Veh §26452.

Forklift, Veh §26307.

Maintenance of brakes, Veh §26453.

Parking brakes.

Operation of system, Veh §26450.

Requirements, Veh §26451.

Power brakes, Veh §26301.

Regulations governing, CCR §§13.1060 to 13.1066.

Scope, CCR §13.1060.

Service brakes on all wheels, Veh §26311.

Operation of system, Veh §26450.

Stopping requirements, Veh §26454.

Exemptions, Veh §26457.

Tests, Veh §26456.

Weight of vehicle for stopping distance purposes, Veh §26455.

Towing vehicles, Veh §§26458, 26458.5.

Trailer coaches and camp trailers, Veh §26303.

Trailers.

Towing vehicles, Veh §26458.5.

Trailers and semitrailers, Veh §26302.

Vacuum brakes, Veh §§26520 to 26522.

Check valves, Veh §26522.

Gauge, Veh §26520.

Warning device, Veh §26521.

**Commercial vehicles.**

Identification lamps, Veh §25351.

Identification markings.

Specifications, CCR §§13.630 to 13.637.

**Dealer responsibilities, Veh §24007.****Deceleration warning lights, Veh**

§25251.5.

Mounting requirements, CCR §13.690.

Operating requirements, CCR §13.731.

Scope of regulation, CCR §13.730.

**Department of highway patrol, Veh**

§24000.

**Diffused lights, Veh §§25400, 25401.****Emergency reflectors, Veh §25300.****Exempt vehicles, Veh §§25800 to 25806.****Exhaust and noise control.**

Certificates of compliance, Veh §§27158, 27158.5.

Certified systems, CCR §13.611.

Inspections, Veh §24011.7.

Installation of exhaust systems or parts, CCR §13.613.

Mufflers.

Inspections, Veh §24011.7.

Sale of exhaust systems or parts, CCR §13.612.

Storage of vehicles at request of air resources board, Veh §27159.

Violations, Veh §42001.2.

**Exhaust emissions devices, older cars.**

Auctioneer responsibilities when selling older cars, Veh §24007.5.

Elderly low-income purchaser of older cars.

Free installation of exhaust devices, Veh §24007.2.

**Exhaust systems generally, Veh**

§§27156, 27159.

Disconnecting, modifying, etc., Veh §42001.14.

**Fender and side lighting, Veh §§25100**

to 25110.

Mounting requirements, CCR §13.688.

**Flares, Veh §25305.****EQUIPMENT FOR VEHICLES —Cont'd****Flashing or warning lights, Veh §§25250 to 25282.**

Animal control enforcement vehicles, Veh §25271.5.

Aqueduct, levee, etc., measurement, Veh §25266.

Armored cars.

Red lights, Veh §25262.

Bucket trucks, Veh §25260.3.

Buses.

Crime alarm lights, Veh §25275.5.

Cable television vehicles, Veh §25274.

Contractor vehicles, Veh §25282.

Coroner vehicles, Veh §25264.

County weed or pest control vehicles, Veh §25261.

Deceleration warning lights, Veh §25251.5.

Mounting requirements, CCR §13.690.

Operating requirements, CCR §13.731.

Scope of regulation, CCR §13.730.

Disaster service worker vehicles.

Red cross, Veh §25259.5.

Emergency vehicles, Veh §25252.

Additional lights, Veh §25259.

Blue lights, flashing, Veh §25258.

Headlamps, Veh §25252.5.

Red cross, Veh §25259.5.

White lights, flashing, Veh §25258.

Exempt vehicles, Veh §§25800 to 25806.

Garbage collection, Veh §25280.

Hazardous substance response vehicles, Veh §25260.4.

Highway maintenance vehicles, Veh §25256.

Husbandry, implements of, Veh §25251.1.

Improper use.

Flashing amber warning, Veh §25268.

Red warning light, Veh §25269.

Land surveyor vehicles, Veh §25278.

Livestock herding vehicles, Veh §25270.5.

Mail vehicles.

Rural vehicles, Veh §25272.

Marshal's department vehicles, certain jurisdictions, Veh §25254.

Mentally retarded or handicapped persons, transporters of, Veh §25276.

Motorcycles, Veh §25251.2.

Mounting requirements for warning lamps generally, CCR §13.700.

Parking enforcement vehicles, Veh §25277.

Personnel aerial lift, Veh §25260.3.

Pest abatement vehicles, Veh §25267.

Pet ambulances, Veh §25271.

Pilot cars, Veh §25270.

Pipeline construction or repair vehicles, Veh §25260.1.

Prohibited generally, Veh §25250.

Public utility vehicles, Veh §25260.

Sanitation district repair vehicles, Veh §25265.

Schoolbuses, Veh §25257.

Backup warning, Veh §25257.5.

Developmentally disabled transporters, Veh §25257.2.

Mechanical testing, CCR §13.682.

Mounting requirements, CCR §13.696.

Strobe lights.

Mounting requirements, CCR §13.695.5.

Scope of regulation, CCR §13.819.

Specifications, CCR §13.820.

School district vehicles, Veh §25273.

Security.

Private security agency vehicles, Veh §25279.

Theft alarms, Veh §25251.4.

**EQUIPMENT FOR VEHICLES —Cont'd****Flashing or warning lights —Cont'd**

Tow trucks, Veh §25253.

House towing trucks, Veh §25263.

Trucks, long loads, Veh §25275.

Warning lamp flasher regulations, CCR §§13.800 to 13.804.

Durability, CCR §13.801.

Nonthermally operated flashers, CCR §13.803.

Performance, CCR §13.801.

Scope of regulation, CCR §13.800.

Thermally operated flashers, CCR §13.802.

Variable load flashers, CCR §13.804.

Warning lamp regulations, CCR §§13.810 to 13.818.

Classification of lamps, CCR §13.812.

Color, CCR §13.816.

Definitions, CCR §13.811.

Durability test requirements, CCR §13.815.

Emergency vehicles, CCR §13.818.

Mechanical test requirements, CCR §13.814.

Photometric tests, CCR §13.817.

Scope of regulation, CCR §13.810.

Special hazard vehicles, CCR §13.818.

Specifications, CCR §13.813.

Temperature test requirements, CCR §13.815.

Water tender vehicles, Veh §25281.

When permitted, Veh §25251.

**Fuses, Veh §25305.****Gross polluters.**

Air pollution control devices, Veh §27156.

**Horns, sirens, and amplification**

devices, Veh §§27000 to 27003.

**Identification lamps.**

Commercial vehicles, Veh §25351.

Passenger carriers, Veh §25350.

**Identification markings.**

Specifications, CCR §§13.630 to 13.637.

**Illuminated signs on public transit**

buses, Veh §25353.

**Lamp adjustment stations.**

See LAMP AND BRAKE ADJUSTING STATIONS.

**Lights.**

Acetylene lamps, Veh §25450.

Motorcycles, Veh §25451.

Nonglaring, Veh §25452.

Aiming, Veh §24012.

Auxiliary lamps.

Beam aimability, CCR §13.713.

Driving, Veh §24402.

Maximum number, Veh §24405.

Mechanical test requirements, CCR §13.711.

Off-highway use, Veh §24411.

Off road use, Veh §24411.

Passing, Veh §24402.

Photometric test requirements, CCR §13.712.

Rear-facing, Veh §24616.

Scope of regulation, CCR §13.710.

Backup lamps, Veh §24606.

Colors.

Showing to front, Veh §25950.

Construction requirements, CCR §§13.640 to 13.648.

Cornering lights.

Mechanical test requirements, CCR §13.721.

Mounting requirements, CCR §13.689.

Photometric test requirements, CCR §13.722.

Scope of regulation, CCR §13.720.

**EQUIPMENT FOR VEHICLES —Cont'd**

**Lights —Cont'd**  
 Darkness.  
   Use during, Veh §24250.  
 Diffused lights, Veh §§25400, 25401.  
 Direction of beams, Veh §25951.  
 Distance requirement, Veh §24251.  
 Driving lamps.  
   Mounting requirements, CCR §13.690.5.  
 Exempt vehicles, Veh §§25800 to 25806.  
 Flashing or warning lights, Veh §§25250 to 25282.  
 Fog lamps, Veh §24403.  
   Aiming, CCR §13.675.  
   Maximum number, Veh §24405.  
   Mounting requirements, CCR §13.691.  
   Testing, CCR §§13.740 to 13.742.  
 Headlamps.  
   Acetylene lamps, Veh §25450.  
     Motorcycles, Veh §25451.  
     Nonglaring, Veh §25452.  
   Maximum number, Veh §24405.  
   Mechanical testing, CCR §§13.676, 13.677.  
   Motorcycles, Veh §§25650, 25650.5.  
     Acetylene lamps, Veh §25451.  
   Motor-driven cycles, Veh §25651.  
   Mounting requirements, CCR §13.692.  
   Multiple beams, Veh §24406.  
   Parked vehicles, Veh §24401.  
   Required, Veh §24400.  
   Single beams, older vehicles, Veh §24410.  
   Upper and lower beam, Veh §24407.  
     Indicator, Veh §24408.  
     Use, Veh §24409.  
 Identification lamps.  
   Commercial vehicles, Veh §25351.  
   Passenger carriers, Veh §25350.  
 Identification markings.  
   Specifications, CCR §§13.630 to 13.637.  
 Lamp adjustment stations.  
   See LAMP AND BRAKE ADJUSTING STATIONS.  
 Lenses.  
   Replacement lenses, CCR §§13.765 to 13.769.  
 Maintenance, Veh §24252.  
 Maximum number, Veh §24405.  
 Mechanical test requirements, CCR §§13.660 to 13.682.  
 Mounting, Veh §24012.  
   Height, Veh §24254.  
   Requirements for mounting, CCR §§13.685 to 13.700.  
 Multiple beams, Veh §24406.  
 Upper and lower beam, Veh §24407.  
   Use of, Veh §24409.  
 Parking lamps, Veh §§24800 to 24802.  
 Passing lamps.  
   Mounting requirements, CCR §13.693.  
 Rear lights, Veh §§24600 to 24616.  
 Regulations.  
   Lighting equipment subject to regulations, CCR §§13.620 to 13.625.  
 Replacement lenses, CCR §§13.765 to 13.769.  
   Definitions, CCR §13.766.  
   Installation instructions, CCR §13.769.  
   Mechanical test requirements, CCR §13.767.  
   Photometric test requirements, CCR §13.768.  
   Scope of regulation, CCR §13.765.  
 Reserve lighting and outage indicators, CCR §§13.770 to 13.777.  
 Defined, CCR §13.771.

**EQUIPMENT FOR VEHICLES —Cont'd**

**Lights —Cont'd**  
 Reserve lighting and outage indicators —Cont'd  
   Installation requirements, CCR §13.777.  
   Operation requirements, CCR §13.773.  
   Scope of regulation, CCR §13.770.  
   Specifications, CCR §13.772.  
   Temperature test requirements, CCR §13.776.  
   Vibration test requirements, CCR §13.775.  
   Voltage requirements, CCR §13.774.  
 Running lamps, CCR §§13.780 to 13.782.  
   Mechanical test requirements, CCR §13.782.  
   Mounting requirements, CCR §13.694.  
   Scope of regulation, CCR §13.780.  
   Size, CCR §13.781.  
 Side and fender lighting, Veh §§25100 to 25110.  
   Generally, Veh §§25100 to 25110. See within this heading, "Side and fender lighting."  
   Side-mounted and supplemental signal lamps, CCR §§13.790 to 13.794.  
 Specifications, Veh §24252.  
 Spotlamps, Veh §24404.  
   Maximum number, Veh §24405.  
 Supplemental signal lamps.  
   Mounting requirements, CCR §13.698.  
 Supplementary illumination system, Veh §24255.  
 Taillamps.  
   Remaining lighted, Veh §24253.  
   Testing, Veh §§26100 to 26104.  
   Compliance with requirements to be demonstrated by, Veh §26104.  
   Data to be shown, CCR §13.625.  
   Mechanical test requirements, CCR §§13.660 to 13.682.  
   Modification of equipment design, Veh §26101.  
   Required, Veh §26100.  
 Turn signals, Veh §§24950 to 24953.  
   Mounting requirements, CCR §13.699.  
   Side-mounted and supplemental signal lamps, CCR §§13.790 to 13.794.  
 Unlawful lights.  
   Operation with, Veh §24003.  
 Upper and lower beam, Veh §24407.  
   Use, Veh §24409.  
**Load projections.**  
 Lamp or flag on, Veh §§24604, 25952.  
 Reflectors, Veh §25952.  
 Side and fender lighting, Veh §25103.  
**Mirrors and windshields,** Veh §§26700 to 26712.  
**Modification of equipment design,** Veh §26101.  
**Mufflers.**  
 Adequate muffler required, Veh §27150.  
 Certificates of compliance, Veh §27150.2.  
 Dismissal of prosecutions, Veh §27150.7.  
 Escape of excessive smoke or other residue, Veh §27153.  
 Exhaust and noise control.  
   Inspections, Veh §24011.7.  
   Modification of systems, Veh §27151.  
   Off-highway vehicles, Veh §27150.  
   Sale of exhaust systems, Veh §27150.1.  
   Sale of non-complying systems, Veh §27150.5.  
   Violations, Veh §42001.2.  
**Noise inspections,** Veh §24007.6.  
**Notice by officer, unlawful operation following,** Veh §24004.  
**Parking lamps,** Veh §§24800 to 24802.

**EQUIPMENT FOR VEHICLES —Cont'd**

**Passenger carriers.**  
 Identification lamps, Veh §25350.  
 Identification markings.  
   Specifications, CCR §§13.630 to 13.637.  
 Traffic signal changing devices, Veh §25352.  
**Pollution control devices.**  
 Auxiliary gasoline fuel tanks, Veh §27156.1.  
 Emergency vehicle exemptions, Veh §27156.2.  
 Exempt vehicles generally, Veh §27156.3.  
 Gross polluters, Veh §27156.  
**Public employee exemptions,** Veh §26708.7.  
**Rear lights,** Veh §§24600 to 24616.  
 Auxiliary lamps, rear-facing, Veh §24616.  
 Backup lamps, Veh §24606.  
 Colors, Veh §25950.  
 Fog taillamps, Veh §24602.  
   Aiming, CCR §13.675.  
   Mechanical testing.  
     Requirements, CCR §13.742.  
   Mounting requirements, CCR §13.691.  
   Scope of regulation, CCR §13.740.  
   Specifications, CCR §13.741.  
   Testing, CCR §§13.740 to 13.742.  
 License plate lights, Veh §24601.  
 Load projections.  
   Lamp or flag on, Veh §24604.  
 Reflectors, Veh §24607.  
   Buses, trailers, housecars and trucks, Veh §24608.  
     Exemption of certain trailers, Veh §24611.  
   Emergency reflectors, Veh §25300.  
   Front of vehicle, Veh §24609.  
     Reflex reflectors, CCR §§13.760 to 13.762.  
   Multiple unit truck reflectors, Veh §24610.  
 Slow moving vehicle emblem, Veh §24615.  
 Taillamps, Veh §24600.  
 Fog taillamps, Veh §24602.  
   Aiming, CCR §13.675.  
   Mechanical testing.  
     Requirements, CCR §13.742.  
   Mounting requirements, CCR §13.691.  
   Scope of regulation, CCR §13.740.  
   Specifications, CCR §13.741.  
   Testing, CCR §§13.740 to 13.742.  
 Stoplamps, Veh §24603.  
   Side-mounted and supplemental signal lamps, CCR §§13.790 to 13.794.  
 Tow trucks and towed vehicles, Veh §24605.  
 Turn signals, Veh §§24950 to 24953.  
**Reflectors,** Veh §24607.  
 Buses, trailers, housecars and trucks, Veh §24608.  
   Exemption of certain trailers, Veh §24611.  
 Colors showing to front, Veh §25950.  
 Emergency reflectors, Veh §25300.  
 Front of vehicle, Veh §24609.  
   Reflex reflectors, CCR §§13.760 to 13.762.  
 Multiple unit truck reflectors, Veh §24610.  
 Use of reflectorizing material, Veh §25500.  
**Regulations.**  
 Adoption of regulations, Veh §26103.  
 Effect of future regulations on current equipment, Veh §26102.

**EQUIPMENT FOR VEHICLES —Cont'd**

**Rope or webbing for loads, Veh** §24005.5.

**Salvage pool.**  
Responsibilities, Veh §24007.6.

**Side and fender lighting, Veh** §§25100 to 25110.  
Clearance and side-marker lamps, Veh §25100.  
Ambulances, Veh §25100.1.  
Cornering lamps, Veh §25107.  
Courtesy lamps, Veh §25105.  
Cowl or fender lamps, Veh §25106.  
Lamps on sides of vehicles, Veh §25102.  
Schoolbuses, Veh §25102.5.  
Mechanical testing, CCR §13.681.  
Mounting requirements, CCR §13.695.  
Scope of regulation, CCR §13.785.  
Specifications, CCR §13.786.  
Loads projecting, Veh §25103.  
Mounting requirements, CCR §13.688.  
Running lamps, Veh §25109.  
Side-mounted and supplemental signal lamps, CCR §§13.790 to 13.794.  
Turn signal mounting requirements.  
Side-mounted turn signal lamps, CCR §13.697.  
Turn signal pilot indicators, Veh §25108.  
Utility flood or loading lamps, Veh §25110.  
Wide vehicles, Veh §25104.

**Signal lights.**  
Turn signals, Veh §§24950 to 24953.

**Slow moving vehicle emblem, Veh** §24615.

**Stoplamps, Veh** §24603.  
Side-mounted and supplemental signal lamps, CCR §§13.790 to 13.794.

**Synthetic rope or webbing for loads, Veh** §24005.5.

**Taillamps, Veh** §24600.  
Fog taillamps, Veh §24602.  
Aiming, CCR §13.675.  
Mechanical testing.  
Requirements, CCR §13.742.  
Mounting requirements, CCR §13.691.  
Scope of regulation, CCR §13.740.  
Specifications, CCR §13.741.  
Testing, CCR §§13.740 to 13.742.  
Remaining lighted, Veh §24253.

**Stoplamps, Veh** §24603.  
Side-mounted and supplemental signal lamps, CCR §§13.790 to 13.794.

**Testing.**  
Lights, Veh §§26100 to 26104.  
Compliance with requirements to be demonstrated by, Veh §26104.  
Data to be shown, CCR §13.625.  
Mechanical test requirements, CCR §§13.660 to 13.682.  
Modification of equipment design, Veh §26101.  
Required, Veh §26100.

**Tires.**  
See TIRES AND TIRE CHAINS.

**Trademark or name to be included on equipment, Veh** §24006.

**Turn signals, Veh** §§24950 to 24953.  
Civil liability for use or nonuse, Veh §25251.3.  
Flashing or warning lights generally. See within this heading, "Flashing or warning lights."  
Lamp-type turn signal, Veh §24951.  
Mounting requirements for lights, CCR §13.699.  
Side-mounted and supplemental signal lamps, CCR §13.791.

**EQUIPMENT FOR VEHICLES —Cont'd**

**Turn signals —Cont'd**  
Side and fender lighting.  
Mounting requirements.  
Side-mounted turn signal lamps, CCR §13.697.  
Turn signal pilot indicators, Veh §25108.  
Side-mounted and supplemental signal lamps, CCR §§13.790 to 13.794.  
Towing of trailers, Veh §24950.  
Types of lights used, Veh §24953.  
Visibility, Veh §24952.

**Unlawful equipment.**  
Notice by officer, unlawful operation following, Veh §24004.  
Sale, transfer or installation, Veh §24005.

**Warning devices.**  
Airbrakes, Veh §26506.  
Flares, Veh §25305.  
Flashing and warning lights generally, Veh §§25250 to 25282.  
Regulations governing warning lamp flashers, CCR §§13.800 to 13.804.  
Regulations governing warning lamps, CCR §§13.810 to 13.818.  
Fusees, Veh §25305.  
Public utility vehicles, Veh §25301.  
Reflectors.  
Emergency reflectors, Veh §25300.  
Vacuum brakes, Veh §26521.

**Wide vehicles.**  
Side and fender lighting, Veh §25104.

**Windshields and mirrors, Veh** §§26700 to 26712.

**ESTIMATES.**

**Charges in excess of estimate, B&P** §9884.9.

**Written estimates, B&P** §9884.9.

**EXAMINATIONS.**

**Emissions inspections.**  
Technician examinations.  
Fees, H&S §44034.1.

**License examinations.**  
Reexamination, B&P §135.  
Subversion of examination, B&P §123.  
Denial, suspension or revocation of license, B&P §496.  
Injunction against, B&P §123.5.

**EXHAUST AND NOISE CONTROL.**

**Certificates of compliance, Veh** §§27158, 27158.5.

**Certified systems, CCR** §13.611.

**Inspections, Veh** §24011.7.

**Installation of exhaust systems or parts, CCR** §13.613.

**Sale of exhaust systems or parts, CCR** §13.612.

**Storage of vehicles at request of air resources board, Veh** §27159.

**Violations, Veh** §42001.2.

**F**

**FACT-BASED ADVERTISING, B&P** §17508.

**FAIR CLAIMS SETTLEMENT PRACTICES, INSURANCE.**

**Auto body repair consumer bill of rights, CCR** §10.2695.85.

**Automobile insurance, CCR** §10.2695.8.

**FALSE ADVERTISING, B&P** §§17500 to 17509, CCR §§16.3370 to 16.3377.  
See ADVERTISING.

**FALSE INSURANCE CLAIMS, Pen** §550.

**FEES.****Air pollution.**

Fees to implement clean air act, H&S §§44225, 44229.

**California tire fee, Pub Res** §42885.

**Dealers.**

Registration, CCR §16.3351.1.  
Payment for each place of business, B&P §§9884, 9884.1.  
Renewal.  
Termination of registration for nonpayment, B&P §9884.3.  
Schedule, B&P §9886.3.

**Emissions inspections.**

Certificate of compliance, CCR §§16.3340.35, 16.3340.35.1.  
Repair of vehicles.  
Costs.

Economic hardship extension, CCR §§16.3340.35, 16.3340.35.1.  
Repair cost waiver, CCR §§16.3340.35, 16.3340.35.1.

Smog check stations.

Department fees, H&S §44060.  
Smog check stations and technicians.  
Examination fees for technicians, H&S §44034.1.

Licenses, H&S §44034.

Test-only facilities.

Fees, CCR §16.3340.7.

**Lamp and brake adjusting stations.**

Certificates, B&P §9889.19.  
Licensing, B&P §9887.2.

**Licenses.**

Duplicate licenses.  
Fee for issuance of duplicate, B&P §122.

Reduction if surplus, B&P §128.5.

**Registration of vehicles, Veh** §§9250.1, 9250.2.

Collection of administrative fees, Veh §9250.18.

**Tire fee, Pub Res** §42885.

**FICTITIOUS LICENSES.**

**Possession or display, B&P** §119.

**FINES.****Advertising.**

False advertising.  
Chapter violations, B&P §17536.  
Injunctions.  
Violation of injunction, B&P §17535.5.

**Air pollution.**

Exhaust systems.  
Disconnecting, modifying, etc., Veh §42001.14.

**Computer crimes, Pen** §502.

**Dealers.**

Violations, B&P §9889.20.

**Emissions inspections.**

Fines and citations, CCR 16.3394.25 to 16.3394.27.  
Misdemeanor violations, H&S §44058.  
Schedule of fines, H&S §44051.  
Failure to pay, H&S §44055.  
Separate violations, H&S §44052.  
Violations outside of schedule, H&S §44056.

**Equipment for vehicles.**

Exhaust systems.  
Disconnecting, modifying, etc., Veh §42001.14.

**Insurance.**

False or fraudulent claims, Pen §550.

**Lamp and brake adjusting stations.**

Violations, B&P §9889.20.

**Licenses.**

Sales of equipment, supplies, etc., for use in violation of provisions, B&P §128.

**FINES —Cont'd**

**Motor vehicle brake friction material reduction**, H&S §25250.62.

**Securities and commodities.**

Civil penalties for violations, Gov §12660.

**Tire fee and recycling management fund.**

False statements, Pub Res §42885.

**Towing arrangements.**

Inducements to public agencies to make towing arrangements, Veh §12110.

**Unfair competition.**

Civil penalty, B&P §17206.

Disabled person as victim.

Additional civil penalty, B&P §17206.1.

Injunctions, violation, B&P §17207.

Senior citizen as victim.

Additional civil penalty, B&P §17206.1.

**Unlicensed activity enforcement**, B&P §146.

**Vehicle code offenses generally**, Veh §42001.

**FINGERPRINTS.**

**To be provided in order to conduct background checks**, B&P §144.

**FLAGS.**

**Load projections**, Veh §24604.

**FLASHING OR WARNING LIGHTS**, Veh §§25250 to 25282.

**FORGERY.**

**Criminal provisions**, Pen §115.

**Licenses.**

Buying or receiving forged license, B&P §119.

**Registration of vehicles.**

False, altered, etc., registration, title, etc., Veh §4463.

**FORKLIFTS.**

**Brakes**, Veh §26307.

**Lighting equipment exemptions**, Veh §25805.

**FORMS.****Dealers.**

Registration, B&P §9884.

**Service contracts**, Ins §12820.

**FRAUD.****Air pollution.**

Accelerated retirement of light-duty vehicles, H&S §§44106, 44107.

**Coupons as gift or prize, misleading representation of**, B&P §17537.11.

**Licenses.**

Altered licenses.

Possession or display of fraudulently altered license, B&P §119.

Fraud, deceit, etc., in obtaining license.

Denial, suspension or revocation of license, B&P §498.

Actions supporting another's licensure, B&P §499.

**Registration of vehicles.**

False, altered, etc., registration, title, etc., Veh §4463.

**Securities and commodities.**

Willful misrepresentation in connection with investigations, Pen §131.

**FRIVOLOUS ACTIONS.****Public safety officers.**

Violation of rights and protections of, Gov §3309.5.

**G****GARBAGE AND REFUSE.****Trucks.**

Required equipment, Veh §27000.

**GARBAGE COLLECTION VEHICLES.****Equipment for vehicles.**

Flashing or warning lights, Veh §25280.

**GAS AND GAS COMPANIES.**

**Conservation services and products, misrepresentation of company affiliation in soliciting sale of**, B&P §17537.5.

**GASOLINE.**

**Variances from state board specifications**, H&S §43013.2.

**GASOLINE STATIONS.**

**Air, water, and pressure gauges, public use**, B&P §§13650 to 13660.

**GIFTS.****Advertising.**

False advertising.

Inducement to visit or to attend sales pitch.

Disclosures, B&P §17537.1.

Unfair trade practices, what constitutes, B&P §17537.2.

**Advertising, use in**, B&P §17537.

**Coupons as gift or prize.**

Misleading representation of, B&P §17537.11.

**GLASS**, Veh §§26700 to 26712.

**Motor vehicle safety standards**, Veh §26708.

**GLOBAL POSITIONING SYSTEMS.**

**Obstruction of driver's view, exceptions**, Veh §26708.

**GOLD SHIELD PROGRAM (GSP)**, CCR

§§16.3392.1 to 16.3392.6.

**Defined**, CCR §16.3392.1.

**Gold shield certification.**

Eligibility, CCR §16.3392.3.

Invalidation, CCR §16.3392.5.

**Gold shield program.**

Hearing and determination, CCR §16.3392.6.

**Smog check stations certified as.**

Responsibilities, CCR §16.3392.2.

**STAR certification.**

Eligibility, CCR §16.3392.3.1.

Performance standards, CCR

§16.3392.3.1.

**STAR program.**

Evaluations, CCR §16.3392.4.

Hearing and determination, CCR

§16.3392.6.1.

**STAR stations.**

Certification.

Invalidation, CCR §16.3392.5.1.

Required services, CCR §16.3392.2.1.

**GOLF CARTS.**

**Low-speed vehicle status**, Veh §385.5.

**GROSS POLLUTERS.**

**Emissions inspections**, H&S §§44080 to 44086.

See EMISSIONS INSPECTIONS.

**Exhaust systems**, Veh §§27156 to 25156.3.

**H****HAZARDOUS SUBSTANCES****RESPONSE.****Equipment for vehicles.**

Flashing or warning lights.

Hazardous substance response vehicles, Veh §25260.4.

**HIGH POLLUTERS.**

**Emissions inspections**, H&S §§44090 to 44096.

See EMISSIONS INSPECTIONS.

**HISTORIC AND SPECIAL INTEREST**

**VEHICLES**, Veh §§5050 to 5052.

**HOUSECARS.**

**Reflectors**, Veh §24608.

**HOUSE TOWING TRUCKS.****Equipment for vehicles.**

Flashing or warning lights, Veh §25263.

**I****IGNITION INTERLOCK DEVICES.****Dealers.**

Installation standards, B&P §9882.14.

Trade standards for repairs, CCR

§16.3363.1.

Authorized installers, CCR §16.3363.3.

Installation standards, CCR

§16.3363.4.

Manufacturer duties as to, CCR

§16.3363.2.

**Install, service or monitor, authority to**, B&P §9807.

**IMPORTED GOODS.**

**Made in U.S.A., improper use**, B&P

§17533.7.

**IMPOUNDMENT.**

**License, suspended or revoked, vehicle driven under**, Veh §14607.6.

**INACTIVE LICENSURE**, B&P §462.

**INCOME TAX.****Gross income.**

Exclusions.

Smog impact fee refunds.

Interest on refunds, Rev&Tax

§17139.5.

**INFRACTIONS.**

**Lamp and brake adjusting stations**,

B&P §9889.21.

**Unlicensed activity enforcement**, B&P

§146.

**Vehicle code offenses generally**, Veh

§42001.

**IN-HOME SUPPORTIVE SERVICES.**

**Records as to persons paid, disclosure**,

Gov §6253.2.

**INJUNCTIONS.****Advertising.**

False advertising.

Violations, B&P §17535.

Penalties for violating injunction,

B&P §17535.5.

**Computer crimes**, Pen §502.

**Dealers.**

Registration.

Injunction of violations, B&P §9884.14.

**Emissions inspections.**

Violations, enjoining or restraining, H&S

§44057.

**False advertising.**

Violations, B&P §17535.

Penalties for violating injunction, B&P

§17535.5.

**License examinations.**

Subversion of examination, B&P §123.5.

**Securities and commodities.**

Enforcement of provisions, Gov §12658.

**Unfair competition.**

Prosecution, B&P §17204.

Remedies, B&P §17203.

Specific or preventive relief, B&P §17202.

Violation of injunction, B&P §17207.

**Violations, enjoining**, B&P §125.5.

**INSPECTIONS.**

**Dismantled vehicles**, Veh §5505.

Sale or transfer of vehicles after inspection, Veh §5506.

**INSPECTIONS —Cont'd**

**Emissions inspections**, H&S §§44000 to 44122.

See EMISSIONS INSPECTIONS.

**Exhaust and noise inspections**, Veh §24011.7.

**Motor vehicle inspection program.**

General regulations, CCR §§16.3340.1 to 16.3340.50.5.

See EMISSIONS INSPECTIONS.

**Motor vehicles.**

Vehicle inspection checkpoint program.

Counties may establish, Veh §2814.1.

**Public records**, Gov §§6253 to 6253.31.

**Vehicle inspection and sobriety checkpoint program.**

Inspection stickers and fees to fund program, Veh §2814.

Use of fines from proceedings to fund program, Pen §1463.15.

**INSURANCE.**

**Classes**, Ins §100.

**Dealers.**

Direct repair program.

Requiring shop to pay for rental vehicle, Ins §758.

Inducement by dealers of insurers to direct business to dealer, Pen §551.

Requiring repairs at specific dealers, Ins §758.5.

**Fair claims settlement practices.**

Auto body repair consumer bill of rights, CCR §10.2695.85.

Automobile insurance, CCR §10.2695.8.

**Fraud.**

Claims, unlawful acts, Pen §550.

Crisis areas.

Declaration, Ins §1874.90.

Public education program, Veh §10904.

Referral by dealer of insurer to direct business to dealer, Pen §551.

**Inspection of vehicles**, Ins §1874.85.

Bill of rights for insured, Ins §1874.87.

Reports, Ins §1874.86.

**Rebates, refunds, commissions, etc., to procure clients.**

Criminal offense, Ins §750.

**Requiring repairs at specific dealers**, Ins §758.5.**Service contracts**, Ins §§12800 to 12825.

Agreements not constituting insurance, Ins §12805.

Definitions, Ins §12800.

Forms, Ins §12820.

Fronting companies prohibited, Ins §12810.

Right to cancel, Ins §12825.

Who may offer, Ins §12810.

**Total loss salvage vehicles**, Veh §11515.**Unlawful acts concerning claims**, Pen §550.**Vehicle protection products**, Ins §116.6.**What constitutes automobile insurance**, Ins §116.

Express warranties covering lubricants, fluids or additives, Ins §116.5.

Service contracts.

Agreements not constituting insurance, Ins §12805.

**INTERNET.****Advertising.**

Purchase or lease of product, B&P §17509.

**Providing information via internet**, B&P §27.**INVESTIGATIONS.****Costs of investigation.**

Direction to licentiate to pay, B&P §125.3.

**INVESTIGATIONS —Cont'd****Dealers.**

Director.

Investigation of violations, B&P §9882.5.

**Securities and commodities**, Gov §12659.

Willful misrepresentation in connection with investigations, Pen §131.

**State departments and agencies**, Gov §§11180 to 11191.**K****KIT VEHICLES.****Emissions inspections.**

Standards for inspections, H&S §44017.4.

**L****LAMP AND BRAKE ADJUSTING**

**STATIONS**, B&P §§9887.1 to 9889.19.

**Certificates**, B&P §§9889.15 to 9889.19.

Definitions, B&P §9889.15.

Fees, B&P §9889.19.

Fleet owner stations, B&P §9888.4.

Issuance by station, B&P §9889.16.

**Definitions**, B&P §9888.1.**Fleet owner stations.**

Certification, B&P §9888.4.

Licensing, B&P §9888.4.

**Infractions**, B&P §9889.21.**Laboratories and equipment, approval**, B&P §9888.2.**Licensing**, B&P §§9887.1 to 9887.4.

Application, B&P §9887.2.

Cancellation, B&P §9887.3.

Denial, suspension and revocation, B&P §§9889.1 to 9889.10.

Accusations against licenses.

Time for filing, B&P §9889.8.

Additional licenses, revocation or suspension, B&P §9889.9.

Administrative procedure, CCR §16.3395.4.

Conviction or guilty pleas, B&P §9889.4.

Director's authority, B&P §9889.1.

Grounds for denial, B&P §9889.2.

Grounds for disciplinary action, B&P §9889.3.

Jurisdiction of director survives expiration or suspension, B&P §9889.7.

Permissible discipline, B&P §9889.5.

Reinstatement of suspended or revoked license, B&P §9889.10.

Surrender of revoked or suspended license, B&P §9889.6.

Director's authority, B&P §§9887.1 to 9887.4.

Duplication, B&P §9887.3.

Fees, B&P §9887.2.

Fleet owner stations, B&P §9888.4.

Nontransferable, B&P §9887.3.

Official station licensing, CCR §§16.3304 to 16.3310.

Ceasing operations as official station, CCR §16.3308.

Change of address, CCR §16.3306.

Change of ownership, CCR §16.3306.

Classes of licenses, CCR §16.3310.

Coverage of regulations, CCR §16.3305.

Display of licenses, documents, etc., CCR §16.3307.

Prices.

Posting, CCR §16.3307.

**LAMP AND BRAKE ADJUSTING STATIONS —Cont'd****Licensing —Cont'd**

Official station licensing —Cont'd

Procedure for licensing, CCR §16.3306.

Records, CCR §16.3307.

Renewal of licenses, CCR §16.3306.

Signs, CCR §16.3309.

Required, B&P §9888.3.

**Official stations.**

Brake adjusting stations.

Classes, CCR §16.3320.

Operation, CCR §16.3321.

Lamp adjusting stations.

Classes of stations, CCR §16.3315.

Operation, CCR §16.3316.

Licensing, CCR §§16.3304 to 16.3310.

Perjury, B&P §9889.22.

Criminal provisions as to perjury, Pen §§118, 126.

Subornation of perjury, Pen §127.

**Prices.**

Posting, CCR §16.3307.

Records, CCR §16.3307.

**Regulations.**

Director's adoption, B&P §9888.2.

Violations, B&P §9887.4.

**Testing laboratories and equipment, approval**, B&P §9888.2.

Violations, B&P §9889.20.

**LAND SURVEYOR VEHICLES.****Equipment for vehicles.**

Flashing or warning lights, Veh §25278.

**LEMON LAW**, CC §1793.1 to 1793.26.**Buyback**, CC §1793.23.

Notice.

Form of notice, CC §1793.24.

**Dispute resolution.**

Arbitration certification program, CCR §§16.3396.1 to 3397.5.

See ARBITRATION CERTIFICATION PROGRAM.

Certification, B&P §§472 to 472.5.

Requirements, CC §1793.22.

**Number of repair attempts**, CC §1793.22.**Restitution under express warranty.**

Sales tax reimbursement, CC §1793.25.

**Transfer of vehicle**, CC §1793.22.

Gag orders, etc., restricted, CC §1793.26.

Sales of transferred vehicle, CC §1793.23.

**LIBRARY.**

Director to establish, B&P §313.

**LICENSE PLATES.**

**Disassembling of vehicle, surrender of documents and plates**, Veh §5500, 5501.

**Historic value, vehicles of**, Veh §5004.

**Surrender of plates**, Veh §5500, 5501.

**LICENSES.****Abandonment date for incomplete application**, B&P §142.**Address of licensees.**

Current address, CCR §16.3303.3.

**Allowing others to use**, B&P §119.

**Altered licenses.**

Possession or display, B&P §119.

**Applicability of law**, B&P §476.**Application.**

Review.

Bureau of automotive repair, CCR §16.3303.2.

Withdrawal.

Effect, B&P §118.

**Arrest records.**

Prohibitions on asking to reveal, B&P §461.

**LICENSES —Cont'd**

**Cash payments of employee wages.**  
Recordkeeping, B&P §140.

**Certified lists, B&P §494.5.**

**Change of address.**  
Notice, B&P §136.

**Child support compliance.**  
Issuance or renewal of license.  
Withholding issuance or renewal, Fam §17520.  
Qualifications for licensing, B&P §29.5.  
Suspension for noncompliance, Fam §17520.

**Child support obligations.**  
Delinquent obligation, denial or nonrenewal of license, B&P §31.

**Complaints against licensees.**  
Board, etc., handling, B&P §129.

**Conspiring to violate provisions, B&P §125.**

**Constituent boards.**  
Action by board against state or federal government, permission to bring, B&P §132.

**Counterfeiting.**  
Buying or receiving counterfeit license, B&P §119.

**Criminal proceedings against licensees.**  
Responsible state agency providing information, Pen §23.

**Dealers.**  
Registration generally.  
See DEALERS.

**Defined, B&P §23.7.**

**Denial.**  
Administrative procedure, CCR §16.3395.4.  
Applicability of provisions, B&P §475.  
Applications.  
Defined, B&P §478.  
Child support enforcement.  
Withholding of issuance or renewal, Fam §17520.  
Conviction of crime.  
Grounds for denial, B&P §480.  
Rehabilitation criteria, B&P §482, CCR §16.3395.  
Relationship to job criteria, B&P §481.  
Substantially related to qualifications or duties.  
Evidentiary effect, B&P §493.  
Definitions, B&P §477.  
Emissions inspections.  
Smog check station and technician licensing.  
Procedures and grounds, H&S §44072.1.  
Examination subversion, B&P §496.  
Exemptions, B&P §476.  
Fraud, deceit, etc., in obtaining license, B&P §498.  
Actions supporting another's licensure, B&P §499.  
Good moral character.  
No requirement to attest to, B&P §484.  
Grounds, B&P §§480, 490.  
Hearings requested by applicant, B&P §487.  
Actions taken by board, B&P §488.  
Denial without hearing, B&P §489.  
Lamp and brake adjusting stations, B&P §§9889.1 to 9889.10.  
Material.  
Defined, B&P §478.  
Notice, B&P §485.  
Contents, B&P §486.  
Procedure upon denial, B&P §485.

**LICENSES —Cont'd**

**Disciplinary actions against licensees.**  
See DISCIPLINARY ACTIONS AGAINST LICENSEES.

**Discrimination.**  
Licensees, discrimination by, B&P §125.6.

**Dishonored check, payment by, B&P §206.**

**Display of licenses, B&P §104.**

**Duplicating licenses.**  
Deceptive duplication, B&P §119.  
Fee for issuance of duplicate, B&P §122.

**Emissions inspections.**  
Fleet owner testing and servicing.  
Licensing fleet owner, H&S §44020.  
Application, renewal, etc., CCR §16.3340.50.1.  
Certificates, CCR §16.3340.50.4.  
Recordkeeping, CCR §16.3340.50.3.  
Requirements, CCR §16.3340.50.  
Suspension or rescission, CCR §16.3340.50.5.  
Administrative procedure, CCR §16.3395.4.  
Smog check stations and technicians, H&S §44014.  
Categories of technician licensure, H&S §44045.5.  
Ceasing operation as licensed station, CCR §16.3340.23.  
Certification of technician trainers, CCR §§16.3340.32, 16.3340.33.  
Certification, voluntary, H&S §44014.2.  
Advertising certification, H&S §44014.4.  
Classification of technicians, CCR §16.3340.28.  
Decertification and recertification of technician trainers, CCR §§16.3340.32.1, 16.3340.33.1.  
Denial of license.  
Administrative procedure, CCR §16.3395.4.  
Convictions, H&S §44072.3.  
Grounds, H&S §44072.1.  
Fees, H&S §44034.  
Fines, failure to pay.  
Nonrenewal of license, H&S §44055.  
Ongoing requirements of technicians, CCR §16.3340.30.  
Probation and terms.  
Types of discipline, H&S §44072.4.  
Procedure, CCR §16.3340.10.  
Procedure for technician licensing, CCR §16.3340.29.  
Qualifications of technicians, CCR §16.3340.28, H&S §44045.5.  
Refusal to renew or to issue new license, H&S §44072.11.  
Retraining technicians, CCR §16.3340.31.  
Standards, H&S §44030.  
Technicians, H&S §44031.5.  
Suspension or revocation, H&S §§44035, 44072.  
Additional licenses, H&S §44072.8.  
Administrative procedure, CCR §16.3395.4.  
Authority of bureau, CCR §16.3340.24.  
Convictions, H&S §44072.3.  
Grounds, H&S §44072.2.  
Jurisdiction, H&S §44072.6.  
Limitations period, H&S §44072.7.  
Reinstatement of license, H&S §44072.9.  
Authority of bureau, CCR §16.3340.24.

**LICENSES —Cont'd**

**Emissions inspections —Cont'd**  
Smog check stations and technicians —Cont'd  
Suspension or revocation —Cont'd  
Surrender of license, H&S §44072.5.  
Temporary suspension, H&S §44072.10.  
Types of discipline, H&S §44072.4.  
Types of stations, H&S §44033.

**Employer identification numbers.**  
Licensee to supply, B&P §30.

**Examinations.**  
Commissioners on examination, B&P §111.  
Improper disclosure of questions, B&P §106.5.  
Reexamination, B&P §135.  
Subversion of examination, B&P §123.  
Denial, suspension or revocation of license, B&P §496.  
Injunction against, B&P §123.5.  
Validation and occupational analyses, B&P §139.

**Expiration.**  
Effect, B&P §118.

**Fees.**  
Proration, B&P §134.  
Reduction if surplus, B&P §128.5.

**Fictitious licenses.**  
Possession or display, B&P §119.

**Forfeiture.**  
Effect, B&P §118.

**Forgery.**  
Buying or receiving forged license, B&P §119.  
Criminal provisions governing forgery, Pen §115.

**Inactive licensure, B&P §462.**

**Interim suspension or restriction order, B&P §494.**

**Lamp and brake adjusting stations, B&P §§9887.1 to 9887.4.**  
Denial, suspension or revocation, B&P §§9889.1 to 9889.10.  
Administrative procedure, CCR §16.3395.4.  
Fleet owner stations, B&P §9888.4.  
Official station licensing, CCR §§16.3304 to 16.3310.  
Ceasing operations as official station, CCR §16.3308.  
Change of address, CCR §16.3306.  
Change of ownership, CCR §16.3306.  
Classes of licenses, CCR §16.3310.  
Coverage of regulations, CCR §16.3305.  
Display of licenses, documents, etc., CCR §16.3307.  
Prices.  
Posting, CCR §16.3307.  
Procedure for licensing, CCR §16.3306.  
Records, CCR §16.3307.  
Renewal of licenses, CCR §16.3306.  
Signs, CCR §16.3309.  
Requirement of licensing, B&P §9888.3.

**Licentiate.**  
Defined, B&P §23.8.

**Local governments.**  
Taxing or restricting licensees of department, B&P §460.

**Military personnel, reinstatement of expired license, B&P §§114 to 118.**

**Misdemeanor offenses by licensees, B&P §§119 to 129.**

**Misrepresentation, B&P §119.**

**Notice that practitioner is licensed, B&P §138.**

**Numbers.**  
Inclusion in advertising.  
Regulations, B&P §137.



**LICENSES —Cont'd****Occupational analyses**, B&P §139.**Proof.**

Condition of action for collection of compensation, B&amp;P §143.

**Public disclosure exemption for financial records in connection with**, Gov §6254.**Public reprovals**, B&P §495.**Renewal.**

Abandonment date for incomplete application, B&amp;P §142.

Child support enforcement.

Withholding of issuance or renewal for noncompliance with obligation, Fam §17520.

Practice between renewal and receipt of evidence of renewal, B&amp;P §121.

Synchronization of renewal dates, B&amp;P §142.

**Sales of equipment, supplies, etc., for use in violation of provisions**, B&P §128.**Social security numbers.**

Licensee to supply, B&amp;P §30.

**Surrender.**

Failure or refusal, B&amp;P §119.

**Suspension or revocation.**

Administrative procedure, CCR §16.3395.4.

Applicability of provisions, B&amp;P §475.

Applications.

Defined, B&amp;P §478.

Child support, failure to meet obligation, B&amp;P §490.5, Fam §17520.

Conviction related to qualifications or duties.

Evidentiary effect, B&amp;P §493.

Definitions, B&amp;P §477.

Drug diversion.

Effect of completion upon suspension or revocation, B&amp;P §492.

Effect, B&amp;P §118.

Emissions inspections.

Smog check station and technician licensing. See within this heading, "Emissions inspections."

Examination subversion, B&amp;P §496.

Exemptions, B&amp;P §476.

Fraud, deceit, etc., in obtaining license, B&amp;P §498.

Actions supporting another's licensure, B&amp;P §499.

Interim suspension or restriction order, B&amp;P §494.

Lamp and brake adjusting stations, B&amp;P §§9889.1 to 9889.10.

Material.

Defined, B&amp;P §478.

Possession or display of suspended license, B&amp;P §119.

Procedure upon, B&amp;P §491.

**Unlicensed activity enforcement**, B&P §§145 to 149.

See UNLICENSED ACTIVITY ENFORCEMENT.

**LIENS.****Dealers.**

Registration.

Prerequisite to filing of lien, B&amp;P §9884.16.

**LIGHTS.****Adjustments.**

Lamp and brake adjusting stations, B&amp;P §§9887.1 to 9889.19.

See LAMP AND BRAKE ADJUSTING STATIONS.

**LIGHTS —Cont'd****Equipment generally.**

See EQUIPMENT FOR VEHICLES.

**Unlawful lights.**

Operation with, Veh §24003.

**LIMITATION OF ACTIONS.****Computer crimes, civil actions**, Pen §502.**Dealers.**

Time for filing complaints against, B&amp;P §9884.20.

**Emissions inspections.**

Licenses, disciplinary proceedings, H&amp;S §44072.7.

**Lamp and brake adjusting stations.**

Licensing.

Denial, suspension and revocation.

Accusations against licenses, B&amp;P §9889.8.

**Securities and commodities.**

Civil penalties for violations, Gov §12660.

**Unfair competition**, B&P §17208.**LIVESTOCK HERDING VEHICLES.****Equipment for vehicles.**

Flashing or warning lights, Veh §25270.5.

**LOCAL GOVERNMENTS.****Licenses.**

Taxing or restricting licensees of department, B&amp;P §460.

**M****MAIL VEHICLES.****Equipment for vehicles.**

Flashing or warning lights.

Rural vehicles, Veh §25272.

**MARQUEES.****Illuminated signs on public transit buses**, Veh §25353.**MENTALLY RETARDED PERSONS, TRANSPORTERS OF.****Equipment for vehicles.**

Flashing or warning lights, Veh §25276.

**METHANOL-GASOLINE****EXPERIMENTAL VEHICLES**, H&S §43843.**MILITARY PERSONNEL.****Business and occupational licenses, reinstatement after expiration**, B&P §§114 to 118.**MIRRORS**, Veh §§26700 to 26712.**MISDEMEANORS.****Advertising.**

False advertising.

Violations, B&amp;P §17534.

**Automotive parts sales.**

Violations as misdemeanors, Veh §12003.

**Dealers.**

Violations, B&amp;P §9889.20.

**Emissions inspections**, H&S §44058.**False advertising.**

Violations, B&amp;P §17534.

**Lamp and brake adjusting stations.**

Violations, B&amp;P §9889.20.

**License applicants.**

Prohibitions on asking to reveal arrest records, B&amp;P §461.

**Licenses.**

Conspiring to violate provisions, B&amp;P §125.

Examinations.

Subversion of examination, B&amp;P §123.

Use of licenses, B&amp;P §119.

**Vehicle code violations**, Veh §40000.7.**MISREPRESENTING NATURE OF BUSINESS**, B&P §17505.**Recreation therapists**, B&P §17505.2.**MOPEDS AND MOTOR-DRIVEN CYCLES.****Headlamps**, Veh §25651.

Mechanical testing, CCR §13.679.

**Motorized scooters.**

Exhaust system modification or alteration.

Manufacturers' notice, Veh §385.5.

Mufflers, Veh §385.5.

**MOTORCYCLES.****Defined**, Veh §400.**Equipment for vehicles.**

Acetylene lamps, Veh §25451.

Exhaust and noise control.

Certified systems, CCR §13.611.

Flashing or warning lights, Veh §25251.2.

Lights.

Headlamps.

Mechanical testing, CCR §13.678, Veh §25650.5.

**Exhaust system**, Veh §27202.1.**Mirrors**, Veh §26709.**Noise limits**, Veh §27202.**MOTORIZED SCOOTERS.****Exhaust system modification or alteration.**

Manufacturers' notice, Veh §385.5.

**Mufflers.**

Exhaust system modification or alteration.

Manufacturers' notice, Veh §385.5.

**MOTOR VEHICLE DEPARTMENT.****Smog impact fee refunds.**

Duties as to refund, Veh §1673.2.

**MUFFLERS.****Adequate muffler required**, Veh §27150.**Certificates of compliance**, Veh §27150.2.**Definition**, Veh §425.**Dismissal of prosecutions**, Veh §27150.7.**Escape of excessive smoke or other residue**, Veh §27153.**Exhaust and noise emissions**, Veh §24011.7.**Gross polluters**, Veh §27156.**Modification of systems**, Veh §27151.**Motorized scooters.**

Exhaust system modification or alteration.

Manufacturers' notice, Veh §385.5.

**Off-highway vehicles**, Veh §27150.**Sale of exhaust systems**, Veh §27150.1.**Sale of non-complying systems**, Veh §27150.5.**Violations**, Veh §42001.2.**N****NEGLIGENCE.****Public offense, existence in**, Pen §20.**NEW MOTOR VEHICLE BOARD.****Funding**, Veh §3016.**NEW MOTOR VEHICLE****WARRANTIES.****Dispute resolution.**

Arbitration certification program, CCR §§16.3396.1 to 3397.5.

See ARBITRATION CERTIFICATION PROGRAM.

Certification, B&amp;P §§472 to 472.5.

Definitions, B&amp;P §472.

Program for certification, B&amp;P §472.1.

**NEW MOTOR VEHICLE WARRANTIES**  
—Cont'd**Dispute resolution** —Cont'd

## Certification —Cont'd

Providing dispute resolution to buyers or lessees, B&P §472.2.

Requirements, CC §1793.22.

**Lemon law buyback**, CC §1793.23.

## Notice.

Form of notice, CC §1793.24.

**Number of repair attempts**, CC

§1793.22.

**Service contract in lieu of express warranty**, CC §1794.41.**Transfer of vehicle**, CC §1793.22.

Gag orders, etc., restricted, CC §1793.26.

Restitution under express warranty.

Sales tax reimbursement to manufacturer, CC §1793.25.

Sellers' disclosures, CC §1793.23.

**NOISE.****Exhaust and noise control.**

Certificates of compliance, Veh §§27158, 27158.5.

Inspections, Veh §24011.7.

Storage of vehicles at request of air resources board, Veh §27159.

Violations, Veh §42001.2.

**Limits**, Veh §§27201 to 27206.

Noise inspections.

Conflict of laws, Veh §24007.6.

**NONREPAIRABLE VEHICLES.****Defined**, Veh §431.**NOTICE.****Emissions inspections.**

Noncompliance, H&S §43012.

**Licentiate, notice that practitioner is licensed**, B&P §138.**Manner**, B&P §124.**Service contracts.**

Cancellation, Ins §12825.

**Smog impact fee refunds.**

Notice with refund, Veh §1673.7.

**Unlicensed activity enforcement.**

Notice to appear in court, B&P §147.

**O****OBSTRUCTION OF DRIVER'S VIEW**, Veh §26708.**OCCUPATIONAL ANALYSES.****Examination validation**, B&P §139.**OFFICIAL STATIONS.****Lamp and brake adjusting stations.**

Generally.

See LAMP AND BRAKE ADJUSTING STATIONS.

**P****PARKING ENFORCEMENT VEHICLES.****Equipment for vehicles.**

Flashing or warning lights, Veh §25277.

**PARTS.****Automotive parts sales**, Veh §§12000 to 12003.

Bureau of automotive repair.

Enforcement of provisions, Veh §12000.

Defective parts, Veh §12002.

Invoices.

Contents, Veh §12001.

Misdemeanors for violations, Veh §12003.

**PARTS** —Cont'd**Automotive parts sales** —Cont'd

Violation of provisions.

Grounds for discipline, CCR

§16.3395.3.

**False advertising.**

Misrepresentations as to new, used, reconditioned, etc., parts, CCR

§16.3374.

**PENAL AND CORRECTIONAL FACILITIES.****Prison industries.**

Salvageable vehicles, restoration and rebuilding of, Veh §286.

**PER DIEM.****Compensation of board and**

**commission members**, B&P §103.

**PERJURY.****Dealers**, B&P §9889.22.**Defined**, Pen §118.**Emissions inspections.**

Conduct constituting, H&S §44059.

**Lamp and brake adjusting stations**,

B&P §9889.22.

**Punishment**, Pen §126.**Subornation of perjury**, Pen §127.**PET AMBULANCES.****Equipment for vehicles.**

Flashing or warning lights, Veh §25271.

**PILOT CARS.****Equipment for vehicles.**

Flashing or warning lights, Veh §25270.

**PIPELINE CONSTRUCTION OR REPAIR.****Equipment for vehicles.**

Flashing or warning lights.

Pipeline construction or repair vehicles, Veh §25260.1.

**PRICES.****Differentials regarding more than one item within same class**, B&P §17507.**False advertising.**

Dealers, price advertising, CCR

§16.3372.1.

**Former price, advertising**, B&P §17501.**Goods sold in multiple units**, B&P §17504.**Lamp and brake adjusting stations.**

Posting of prices, CCR §16.3307.

**PRISON TERMS.****Computer crimes**, Pen §502.**Insurance.**

False or fraudulent claims, Pen §550.

**Perjury**, Pen §126.**Towing arrangements.**

Inducements to public agencies to make towing arrangements, Veh §12110.

**PRIVATE SECURITY AGENCY VEHICLES.****Equipment for vehicles.**

Flashing or warning lights, Veh §25279.

**PRIZES.****Advertising.**

False advertising.

Inducement to visit or to attend sales pitch.

Disclosures, B&P §17537.1.

Unfair trade practices, what constitutes, B&P §17537.2.

**Advertising, use in**, B&P §17537.**Coupon as prize or gift.**

Misleading representation of, B&P §17537.11.

**PRIZES** —Cont'd**Inducements to attend sales**

**presentation or visit location**, B&P §17537.4.

**PUBLIC AGENCIES.****Emissions inspections.**

Certificate of compliance.

Public agency vehicles, H&S §44019.

**PUBLIC FUNDS.****Brake friction materials water**

**pollution fund**, H&S §25250.64.

**PUBLIC OFFICERS AND EMPLOYEES.****Motor vehicle equipment and**

**condition exemptions**, Veh §26708.7.

**PUBLIC RECORDS**, Gov §§6250 to 6254.**Accessibility, guidelines as to**, Gov §6253.4.**Disclosure, exemptions**, Gov §6254.**License applications, financial records included in**, Gov §6254.**Public records act.**

Agency to assist in inspection, Gov §6253.1.

Controlling disclosure of information.

Allowing party subject to disclosure to control, Gov §6253.3.

Definitions, Gov §6252.

Electronic format, release in, Gov §6253.9.

Guidelines, Gov §6253.

Inspection conditions, Gov §6253.

Minimum standards for inspections, Gov §6253.

Review, audit or report on agency, Gov §6253.31.

**PUBLIC SAFETY OFFICERS.****Violation of rights and protections of**, Gov §3309.5.**PUBLIC UTILITIES.****Equipment for vehicles.**

Flashing or warning lights.

Public utility vehicles, Veh §25260.

Warning devices.

Public utility vehicles, Veh §25301.

**R****RECREATION THERAPISTS.****Misrepresenting nature of business**, B&P §17505.2.**RED CROSS.****Equipment for vehicles.**

Flashing or warning lights, Veh §25259.5.

**REFUNDS.****Smog impact fee refunds.**

See SMOG IMPACT FEE REFUNDS.

**REGISTRATION OF VEHICLES**, Veh §4000.**Body repair.**

Application, B&P §9889.52.

**Certificates of title.**

Transfers of title or interest.

Emissions statement, Veh §5751.5.

Fees, Veh §9255.2.

**Commercial vehicles.**

Weight greater than 10,000 pounds, Veh §4000.6.

**Dealers.**

See DEALERS.

**Disassembling of vehicle.**

Inspection to determine identity of vehicle, Veh §5505.

**REGISTRATION OF VEHICLES**

—Cont'd

**Disassembling of vehicle** —Cont'd

Surrender of documents and plates, Veh §§5500, 5501.

**Emissions inspections.**

Initial registration, CCR §16.3340.6.

Transfers of title or interest, Veh §5751.5.

**Exemption of vehicle from fees.**

Free registration, Veh §4001.

**Exemption of vehicle under permit.**

Not required to register, Veh §4002.

One-trip permits.

Not required to register, Veh §4003.

**False, altered, etc., registration, title, etc.,** Veh §4463.**Fees,** Veh §9250.2.

Applicability of law, Veh §9250.

Collection of administrative fees, Veh §9250.18.

Increase in fees, Veh §9250.1.

Permit fees, Veh §9258.

Transfer of ownership, Veh §9255.2.

**One-trip permits,** Veh §4003.5.

Not required to register, Veh §4003.

**Original registration.**

Temporary permits, Veh §§4156, 9257.5.

**Permits, exemption of vehicle under.**

Not required to register, Veh §4002.

One-trip permits.

Not required to register, Veh §4003.

**Pollution control devices.**

Certificate of compliance, Veh §§4000.1, 4000.2.

Biennial certification, Veh §4000.3.

**Refusal of registration.**

Application for model year

determination, Veh §4750.1.

**Registration year,** Veh §506.**Required,** Veh §4000.

Use of vehicle primarily in California requires California registration, Veh §4000.4.

**Sacramento metropolitan air quality management district.**

Surcharge on vehicle registration fees, H&amp;S §41081.

**Salvage or dismantled vehicles,** Veh §5505.

Certificate of inspection or verification form, Veh §5506.

**Surrender of registration documents,** Veh §§5500, 5501.**Temporary permits,** Veh §§4156, 9257.5.**Total loss salvage vehicles, identity inspections,** Veh §5505.

Sale or transfer of vehicles after inspection, Veh §5506.

**Transfers of title or interest.**

Emissions statement, Veh §5751.5.

Fees, Veh §9255.2.

**REGULATIONS.****Air pollution.**

Vehicular air pollution control.

Used vehicles.

Heavy-duty vehicles, H&amp;S §43701.

**Americans with disabilities act.**

Conformity to act, B&amp;P §313.2.

**Emissions inspections.**

Suspension or revocation by director, H&amp;S §44072.

**Equipment for vehicles.**

Adoption of regulations, Veh §26103.

Effect of future regulations on current equipment, Veh §26102.

**Lamp and brake adjusting stations.**

Adoption, B&amp;P §9888.2.

Violation, B&amp;P §9887.1.

**Procedure,** B&P §313.1.**REGULATIONS** —Cont'd**Violation.**

Citations.

Issuance of citation, B&amp;P §12.5.

**REPAIR DEALERS.**

Generally, B&amp;P §§9880 to 9889.68.

See DEALERS.

**REPLACED PARTS.**

Return to customer, B&amp;P §9884.10.

**REPORTS.****Air pollution.**

Accelerated retirement of light-duty vehicles.

Progress reports, H&amp;S §44104.5.

**Consumer affairs department.**

Director's report to governor and legislature, B&amp;P §312.

Reports from boards, etc., B&amp;P §127.

**Insurance claims handling.**

Inspection of vehicles, Ins §1874.86.

**REPOSSESSORS.**

Tow trucks, use of, Veh §615.

**RESTITUTION.**

Orders for restitution, B&amp;P §125.5.

**Securities and commodities.**

Enforcement of provisions, Gov §12658.

**RESTRAINING ORDERS.****Emissions inspections.**

Violations, enjoining or restraining, H&amp;S §44057.

**Unfair competition.**

Specific or preventive relief, B&amp;P §17202.

**Violations, orders restraining,** B&P §125.7.

Temporary orders, B&amp;P §125.8.

**RETIREMENT OF VEHICLES.****Accelerated retirement of light-duty vehicles,** H&S §44100 to 44122.

See AIR POLLUTION.

**Voluntary retirement.**

Consumer assistance program, CCR §§16.3394.1 to 16.3394.7.

**REVOLVING DOOR.****Boards.**

Public members.

Prior business, professional, etc., pursuits, B&amp;P §450.5.

**RIGHT OF ENTRY.**

Emissions inspections, H&amp;S §43012.

**RULES OF THE ROAD.**

Horns, use of, Veh §27001.

**S****SACRAMENTO METROPOLITAN AIR QUALITY MANAGEMENT DISTRICT.**

Surcharge on vehicle registration fees, H&amp;S §41081.

**SAFETY BELTS.**

Noncomplying equipment, sale of, Veh §27302.

**SALES.**

Automotive parts sales, Veh §§12000 to 12003.

Bureau of automotive repair.

Enforcement of provisions, Veh §12000.

Defective parts, Veh §12002.

Invoices.

Contents, Veh §12001.

Misdemeanors for violations, Veh §12003.

**SALES** —Cont'd

Warranties, CC §§1792 to 1795.

See WARRANTIES.

**SALES AND USE TAXES.****Automobile sales warranties,**

manufacturer's reimbursement for sales tax refunded to new buyer or lessee for restitution under, CC §1793.25.

**Emissions control label,** Rev&Tax §6263.**Vehicles.**

Sales warranties, manufacturer's reimbursement for sales tax refunded to new buyer or lessee for restitution under, CC §1793.25.

**SALVAGE POOL.**

Responsibilities, Veh §24007.6.

**SALVAGE VEHICLES.****Registration of salvage or dismantled vehicles,** Veh §5505.

Certificate of inspection or verification form, Veh §5506.

**Revived salvage vehicle, defined,** Veh §521.5.**Salvage vehicle rebuilder, defined,** Veh §543.5.**Total loss salvage vehicles,** Veh §11515.**Vehicle acquisitions, documentation required by CHP,** Veh §221.**SAN FRANCISCO.****Emissions inspections.**

Enhanced inspection and maintenance program.

San Francisco Bay area basin, H&amp;S §44003.5.

**SCHOOL BUSES.****Equipment for vehicles.**

Flashing or warning lights, Veh §25257.

Backup warning, Veh §25257.5.

Developmentally disabled transporters, Veh §25257.2.

Mechanical testing, CCR §13.682.

Mounting requirements, CCR §13.696.

Strobe lights.

Mounting requirements, CCR §13.695.5.

Scope of regulation, CCR §13.819.

Specifications, CCR §13.820.

**Side and fender lighting.**

Lamps on sides of vehicles, Veh §25102.5.

Scope of regulation, CCR §13.785.

Specifications, CCR §13.786.

Mechanical testing, CCR §13.681.

Mounting requirements, CCR §13.695.

**Stop signal arm,** Veh §25257.**SCHOOL DISTRICT VEHICLES.****Equipment for vehicles.**

Flashing or warning lights, Veh §25273.

**SECURITIES AND COMMODITIES.****Civil penalties for violations,** Gov §12660.

Definitions, Gov §12657.

Enforcement of provisions, Gov §12658.

Investigations, Gov §12659.

**Powers of enforcement under federal laws,** Gov §12661.**Willful misrepresentation in connection with investigations,** Pen §131.**SECURITY.****Equipment for vehicles.**

Flashing or warning lights.

Private security agency vehicles, Veh §25279.

**SECURITY INTERESTS IN MOTOR VEHICLES.**

**Legal owner, secured party as,** Veh §370.

**SEMITRAILERS.**

**Equipment for vehicles.**  
Brakes, Veh §26302.

**SERVICE CONTRACTS,** Ins §§12800 to 12825.

**Agreements not constituting insurance,** Ins §12805.

**Definitions,** Ins §12800.

**Forms,** Ins §12820.

**Fronting companies prohibited,** Ins §12810.

**Right to cancel,** Ins §12825.

**Who may offer,** Ins §12810.

**SERVICE OF PROCESS.**

**Manner of notice,** B&P §124.

**State departments and agencies.**

Investigations, Gov §11184.

**SERVICE STATIONS.****Disabled persons.**

Refueling service for disabled persons,  
B&P §13660.

**SIGNS.****Buses.**

Illuminated signs.  
Santa Monica, illuminated advertising signs, Veh §25353.1.  
Illuminated signs on public transit buses,  
Veh §25353.

**Dealers.**

Display, CCR §16.3351.3.  
Notice to public concerning contact with bureau, B&P §9884.17.  
Specifications, CCR §16.3351.4.

**Emissions inspections.**

Smog check stations, CCR §16.3340.22.  
Repair cost limit signs, CCR §16.3340.22.2.  
Replacement, CCR §16.3340.22.3.  
Service signs, CCR §16.3340.22.1.

**Lamp and brake adjusting stations.**

Official stations, CCR §16.3309.

**Service stations.**

Refueling service for disabled persons,  
B&P §13660.

**SMOG.****Air pollution.**

Emissions inspections, H&S §44000 to 44122.  
See EMISSIONS INSPECTIONS.  
Generally.  
See AIR POLLUTION.

**SMOG IMPACT FEE REFUNDS.**

**Claims,** Veh §1673.4.

**Erroneous payment,** Veh §1673.5.

**False claims,** Veh §1673.6.

**Motor vehicle department.**

Duties as to refund, Veh §1673.2.

**Notice with refund,** Veh §1673.7.

**Registered owner or lessee.**

Defined, Veh §1673.  
Interest, exclusion from gross income,  
Rev&Tax §17139.5.

**SOBRIETY CHECKPOINTS.****Vehicle inspection and sobriety checkpoint program.**

Inspection stickers and fees to fund program, Veh §2814.  
Use of fines from proceedings to fund program, Pen §1463.15.

**SOCIAL SECURITY NUMBERS.**

**Licensee to supply,** B&P §30.

**SOLICITATION OF SALES.**

**At residence or by telephone,** B&P §17500.3.

**SONG-BEVERLY CONSUMER WARRANTY ACT.**

**Warranties generally,** CC §§1790 to 1795.  
See WARRANTIES.

**SPECIAL HAZARD VEHICLES.****Equipment for vehicles.**

Flashing or warning lights.  
Warning lamp regulations, CCR §13.818.

**SPECIALY CONSTRUCTED VEHICLES.****Emissions inspections.**

Standards for inspections, H&S §44017.4.

**STATE DEPARTMENTS AND AGENCIES.****Investigations,** Gov §§11180 to 11191.

Assistance at request of attorney general,  
Gov §11180.5.

Confidential information, Gov §11183.  
Contempt for failure to appear, Gov §11188.

Delegation of powers, Gov §11182.

Discovery, Gov §§11186, 11187, 11189.  
Matters that may be investigated, Gov §11180.

Permissible activities, Gov §11181.

Service of process and subpoenas, Gov §11184.

Show cause orders, Gov §11188.

Witnesses, Gov §§11185, 11186.

Fees, Gov §11191.

Right of party to attendance of, Gov §11190.

**STATIONS.****Lamp and brake adjusting stations.**

See LAMP AND BRAKE ADJUSTING STATIONS.

**STATUTE OF LIMITATIONS.****Computer crimes, civil actions,** Pen

§502.

**Emissions inspections.**

Licenses, disciplinary proceedings, H&S §44072.7.

**Lamp and brake adjusting stations.****Licensing.**

Denial, suspension and revocation.  
Accusations against licenses, B&P §9889.8.

**Securities and commodities.**

Civil penalties for violations, Gov §12660.

**Unfair competition,** B&P §17208.**SUBORNATION OF PERJURY,** Pen

§127.

**SUBPOENAS.****State departments and agencies.**

Investigations, Gov §11184.

## T

**TANNER CONSUMER PROTECTION ACT.****New motor vehicle warranties.**

Dispute resolution after attempts to conform, CC §1793.22.

**TELEMARKETING.****Solicitation of sales at residence or by telephone,** B&P §17500.3.**TELEPHONE DIRECTORY.****Advertising.**

Unlicensed activity enforcement.  
Notice to cease telephone directory advertising, B&P §149.

**TEMPORARY RESTRAINING ORDERS.****Emissions inspections.**

Violations, enjoining or restraining, H&S §44057.

**Unfair competition.**

Specific or preventive relief, B&P §17202.

**Violations, orders restraining,** B&P

§125.8.

**TIRES AND TIRE CHAINS,** CCR

§§13.1080 to 13.1087, Veh §§27450 to 27503.

**California tire fee,** Pub Res §42885.

**Condition and use of tires,** CCR

13.1087.

**Definitions,** CCR 13.1081.

**New tires.**

Marketing, CCR 13.1083.

Requirements, CCR 13.1082.

**Noise standards,** Veh §§27502, 27503.

**Noncomplying, sale of,** Veh §27455.

**Radial tire inner tubes.**

Identification markings, CCR 13.1084.

**Regrooved tires.**

Defined, CCR 13.1081.

Design and construction, CCR 13.1086.

**Scope of provisions,** CCR 13.1080.

**Size and capacity of tires and rims,** CCR 13.1085.

**Tire recycling management fund,** Pub

Res §42885.

Expenditures from fund, Pub Res §42889.

**TOWING.**

**Definitions,** Veh §615.

**Equipment for vehicles.****Brakes.**

Towing vehicles, Veh §§26458, 26458.5.

Flashing or warning lights, Veh §25253.

House towing trucks, Veh §25263.

**Identification on truck,** Veh §615.

**Inducements to public agencies to make towing arrangements,** Veh

§12110.

Dealers, CCR §16.3368.

Drivers' license suspension for violation,

Veh §13351.85.

**Lamps for tow trucks and towed vehicles,** Veh §24605.

**Removal of parked or abandoned vehicles.,** Veh §22651.07.

**TRADEMARKS.****Equipment for vehicles.**

Trademark or name to be included on equipment, Veh §24006.

**TRAILERS.****Equipment for vehicles.**

Brakes, Veh §26302.

Towing vehicles, Veh §26458.5.

Trailer coaches and camp trailers, Veh §26303.

**Reflectors,** Veh §24608.

Exemptions, Veh §24611.

**TRUCK REFLECTORS,** Veh §24608.

**Multiple unit truck reflectors,** Veh

§24610.

**TRUCKS.****Equipment for vehicles.**

Exhaust and noise control.

Heavy trucks.

Certified systems, CCR §13.611.

Light trucks.

Certified systems, CCR §13.611.

**Long load warnings.**

Equipment for vehicles.

Flashing or warning lights, Veh

§25275.

**TRUCKS** —Cont'd

Pickup truck, defined, Veh §471.

## U

**UNFAIR COMPETITION.****Attorney general.**

Notice of appellate proceedings to attorney general, B&P §17209.

**Board within department of consumer affairs.**

Defined, B&P §17201.5.

**Cumulative nature of penalties or remedies, B&P §17205.**

Defined, B&P §17200.

**Disabled person as victim.**

Fines.

Additional civil penalty, B&P §17206.1.

**Fines.**

Civil penalty, B&P §17206.

Disabled person as victim.

Additional civil penalty, B&P §17206.1.

Injunctions, violation, B&P §17207.

Senior citizen as victim.

Additional civil penalty, B&P §17206.1.

**Injunctions.**

Prosecution, B&P §17204.

Remedies and jurisdiction, B&P §17203.

Specific and preventive relief, B&P §17202.

Violation, B&P §17207.

**Limitation of actions, B&P §17208.****Local consumer affairs agency.**

Defined, B&P §17201.5.

**Person.**

Defined, B&P §17201.

**Remedies, B&P §17203.**

Cumulative nature of penalties or remedies, B&P §17205.

**Senior citizen as victim.**

Fines.

Additional civil penalty, B&P §17206.1.

**Specific or preventive relief, B&P §17202.****UNIFORM COMMERCIAL CODE.****Warranties.**

Conflict of laws, CC §1790.3.

**UNLICENSED ACTIVITY**

ENFORCEMENT, B&P §§145 to 149.

**Advertising.**

Telephone directory advertisements.

Notice to cease, B&P §149.

**Citations.**

Administrative citation system.

Authorized for unlicensed persons, B&P §148.

**Fines, B&P §146.****Infractions for violations, B&P §146.****Legislative intent, B&P §145.****Notice to appear in court, B&P §147.****USED CARS.**

Transfer smog certificates, Veh §4000.1.

## V

**VEHICLE AND INSPECTION REPAIR FUND.**

Abolition and transfer of proceeds into vehicle inspection and repair fund, H&S §44062.

Abolition of predecessor funds and transfer of proceeds into vehicle inspection and repair fund, H&S §44062.

Availability of funds, B&P §9886.2.

Created, B&P §9886.

**VEHICLE AND INSPECTION REPAIR FUND** —Cont'd

Disposition of revenue collected, B&P §9886.

**Emissions inspections.**

Fees deposited into fund, H&S §44060.

Fines and fees deposited into fund, H&S §44061.

High polluter repair or removal account, H&S §§44090, 44091.

Litigation proceeds from certain case transferred to fund, H&S §44063.

Fee schedule, B&P §9886.3.

Payments from fund, B&P §9886.4.

Reports, B&P §9886.1.

**VEHICLE EQUIPMENT.****Generally.**

See EQUIPMENT FOR VEHICLES.

**VEHICLE IDENTIFICATION NUMBERS.**

Definition, Veh §671.

**Trade standards for repairs.**

Restrictions on things done to VIN, CCR §16.3364.

**VEHICLE INSPECTION AND SOBRIETY CHECKPOINT PROGRAM.**

Inspection stickers and fees to fund program, Veh §2814.

Use of fines from proceedings to fund program, Pen §1463.15.

**VEHICLE REGISTRATION.**

See REGISTRATION OF VEHICLES.

**VIDEO RECORDINGS.****Motor vehicles.**

Obstruction of driver's view, Veh §26708.

## W

**WAGES.**

Cash payments of employee wages.

Recordkeeping, B&P §140.

WARRANTIES, CC §§1790 to 1795.

Air conditioning equipment, CC §1795.1.

**Air pollution.**

Vehicular air pollution control.

New motor vehicles, H&S §43204.

Defects related to emissions.

Manufacturers to recommend diagnoses and repair procedures, H&S §43210.5.

Light and medium duty vehicles, H&S §43205.

Non-light and medium duty vehicles, H&S §43205.5.

**As is.**

Defined, CC §1791.3.

Sales warranties, CC §1792.5.

**Commercial code.**

Conflict of laws, CC §1790.3.

**Construction and interpretation.**

Severability of provisions, CC §1790.2.

Cumulative nature of remedies, CC §1790.4.

Date of purchase and repairs, giving of receipts showing, CC §1795.6.

**Definitions.**

As is, CC §1791.3.

Express warranties, CC §1791.2.

Fitness, implied warranty, CC §1791.1.

Merchantability, implied warranty, CC §1791.1.

With all faults, CC §1791.3.

**WARRANTIES** —Cont'd

Duration of implied warranties, CC §1795.5.

**Enforceability.**

Waivers disfavored, CC §1790.1.

**Express warranties.**

Defined, CC §1791.2.

Sales warranties, CC §1793.

Alternative repair suggestions, CC §1794.5.

Independent service providers working on express warranties.

Manufacturer liability, CC §1793.6.

Manufacturers' duties, CC §1793.2.

Nonmanufacturer making express warranty, CC §1795.

Service contract in lieu of express warranty, CC §1794.4.

Vehicle or appliance service contract, CC §1794.41.

Service facility not provided, CC §1793.3.

Manufacturer liability, CC §1793.5.

Time to exercise service option, CC §1793.4.

Extension of warranty, CC §1793.1.

Service or repairs, extension during, CC §§1795.6, 1795.7.

Federal standards for disclosure of warranty terms, CC §1793.1.

Heating equipment, CC §1795.1.

**Implied warranties.**

Disclaimer.

Sales warranties, CC §1792.3.

Fitness.

Defined, CC §1791.1.

Sales warranties, CC §§1792.1, 1792.2.

Merchantability.

Defined, CC §1791.1.

Sales warranties, CC §1792.

Waiver.

Sales warranties, CC §1792.3.

**Insurance on automobiles.**

What constitutes automobile insurance.

Express warranties covering lubricants, fluids or additives, Ins §116.5.

**Lemon law.**

Sales or use tax refunded, reimbursement of manufacturer for, CC §1793.25.

Magnuson-Moss Act disclosure standards, conformity to, CC §1793.1.

Reimbursement of manufacturer for sales or use tax refunded to buyer or lessee of new motor vehicle under warranty, CC §1793.25.

Repair order or invoice, written notice of warranty, CC §1793.1.

**Repairs.**

Sales or use tax refunded to buyer or lessee of new motor vehicle under warranty, manufacturer's reimbursement for, CC §1793.25.

Sales warranties, CC §§1792 to 1795.

As is, CC §1792.5.

Damages for buyer, CC §1794.

Damages for seller or service provider, CC §1794.1.

Express warranties, CC §1793.

Alternative repair suggestions, CC §1794.5.

Independent service providers working on express warranties.

Manufacturer liability, CC §1793.6.

Manufacturers' duties, CC §1793.2.

Motor vehicles.

Arbitration certification program.

See ARBITRATION

CERTIFICATION PROGRAM.

**WARRANTIES —Cont'd****Sales warranties —Cont'd**

Express warranties —Cont'd

Motor vehicles —Cont'd

Dispute resolution, CC §1793.22.

Arbitration certification program,  
CCR §§16.3396.1 to 3397.5.Requirements for dispute  
resolution generally, CC  
§1793.22.Number of repair attempts, CC  
§1793.22.Returned vehicles, disclosures, CC  
§§1793.23, 1793.24.Transfer of vehicle, CC §1793.22.  
Gag orders, etc., restricted, CC  
§1793.26.Sales tax reimbursement to  
manufacturer, CC §1793.25.Nonmanufacturer making express  
warranty, CC §1795.Service contract in lieu of express  
warranty, CC §1794.4.Vehicle or appliance service contract,  
CC §1794.41.Service facility not provided, CC  
§1793.3.

Manufacturer liability, CC §1793.5.

Time to exercise service option, CC  
§1793.4.

Fitness.

Disclaimer, CC §1792.4.

**WARRANTIES —Cont'd****Sales warranties —Cont'd**

Fitness —Cont'd

Manufacturers' implied warranty, CC  
§1792.2.Retailers' or distributors' implied  
warranty, CC §1792.2.

Waiver, CC §1792.3.

Merchantability.

Disclaimer, CC §1792.4.

Implied warranty of merchantability,  
CC §1792.

Waiver, CC §1792.3.

Motor vehicles.

Service contract in lieu of express  
warranty, CC §1794.41.

With all faults, CC §1792.5.

**Service contracts.**Offer in lieu of express warranty, CC  
§1794.4.Vehicle or appliance service contract,  
CC §1794.41.**Severability of provisions**, CC §1790.2.**Title of provisions**, CC §1790.**Tolling of warranty period during  
repairs or service**, CC §§1795.6,  
1795.7.**Used goods as covered by warranty**,

CC §1795.5.

**Vehicle protection products**, Ins §116.6.**Waivers.**

Strict construction against, CC §1790.1.

**WARRANTIES —Cont'd****With all faults.**

Defined, CC §1791.3.

Sales warranties, CC §1792.5.

**WATER TENDERS.****Equipment for vehicles.**

Flashing or warning lights.

Private water tender vehicles, Veh  
§25281.**WINDOWS.****Obstruction of driver's view**, Veh  
§26708.**WINDSHIELDS**, Veh §§26700 to 26712.**WITNESSES.****State departments and agencies.**

Investigations, Gov §§11185, 11186.

Fees, Gov §11191.

Right of party to attendance of, Gov  
§11190.**WRECKERS.****Equipment for vehicles.**

Brakes.

Towing vehicles, Veh §§26458, 26458.5.

Flashing or warning lights, Veh §25253.

**Inducements to public agencies to  
make towing arrangements**, Veh  
§12110.Drivers' license suspension for violation,  
Veh §13351.85.**Lamps for tow trucks and towed  
vehicles**, Veh §24605.



## **PDF CD enclosed**

**This CD contains: Laws and Regulations Relating to Automotive Repair Dealers  
Licensed Official Stations and Licensed Smog Check Stations - Includes Statutory  
Amendments Through January 1 2014 and Regulations Through March 14, 2014.**